

A Brain-Friendly Guide

Head First

C#

Covers
C# 3.0 and
Visual Studio 2008



Boss your
data around
with LINQ

**A Learner's Guide to
Real-World Programming
with C# and .NET**

Discover the
secrets of
abstraction and
inheritance



Build a fully
functional
retro classic
arcade game



Learn how
extension
methods helped
Sue bend the
rules in Objectville



See how Jim used
generic collections to
wrangle his data

O'REILLY®

Andrew Stellman
& Jennifer Greene

Head First C#

C#/.NET

What will you learn from this book?

Head First C# is a complete learning experience for object-oriented programming, C#, and the Visual Studio IDE. Built for your brain, this book covers C# 3.0 and Visual Studio 2008, and teaches everything from garbage collection to extension methods to double-buffered animation. You'll also master C#'s hottest and newest syntax, LINQ, for querying your data in .NET collections, SQL databases, and more. By the time you're through, you'll be a proficient C# programmer, designing and coding large-scale applications.

Learn how to get the IDE to do your grunt work for you.

Create a beehive simulation program using double-buffered animation.

Understand the difference between classes and objects.

Exercise your C# skills by building an invaders game...
...and creating a role-playing game with deadly enemies.

Inheritance

Encapsulation

Abstraction

Master the principles of **Polymorphism** object-oriented programming.

Why does this book look so different?

We think your time is too valuable to spend struggling with new concepts. Using the latest research in cognitive science and learning theory to craft a multi-sensory learning experience, *Head First C#* uses a visually rich format designed for the way your brain works, not a text-heavy approach that puts you to sleep.

US \$49.99

CAN \$49.99

ISBN-10: 0-596-51482-4

ISBN-13: 978-0-596-51482-2



9

Safari
Books Online

Free online edition
with purchase of this book.
Details on last page.

O'REILLY[®]

www.oreilly.com
www.headfirstlabs.com

"If you want to learn C# in depth and have fun doing it, this is **THE** book for you."

—Andy Parker,
fledgling C# programmer

"If you've been turned off by more conventional books on C#, you'll love this one!"

—Jay Hilyard,
*Software Developer,
co-author of
C# 3.0 Cookbook*

"Head First C# is a highly enjoyable tutorial, full of memorable examples and entertaining exercises."

—Joseph Albahari,
*C# Design Architect at
Egton Medical Information
Systems, the UK's largest
primary healthcare
software supplier, co-author
of C# 3.0 in a Nutshell*

Advance Praise for *Head First C#*

“I’ve never read a computer book cover to cover, but this one held my interest from the first page to the last. If you want to learn C# in depth and have fun doing it, this is THE book for you.”

— **Andy Parker, fledgling C# programmer**

“Head First C# is a great book for hobbyist programmers. It provides examples and guidance on a majority of the things [those] programmers are likely to encounter writing applications in C#.”

— **Peter Ritchie, Microsoft MVP (2006-2007), Visual Developer, C#**

“With Head First C#, Andrew and Jenny have presented an excellent tutorial on learning C#. It is very approachable while covering a great amount of detail in a unique style. If you’ve been turned off by more conventional books on C#, you’ll love this one.”

— **Jay Hilyard, Software Developer, co-author of *C# 3.0 Cookbook***

“Head First C# is perfect blend of unique and interesting ways covering most of the concepts of programming. Fun exercises, bullet points, and even comic strips are some of the catchy and awesome works that this book has. The game-based labs are something that you really don’t want to miss. [This book is] a great work... the novice as [well as the] well-experienced will love this book. GREAT JOB!”

— **Aayam Singh, .NET professional**

“Head First C# is a highly enjoyable tutorial, full of memorable examples and entertaining exercises. Its lively style is sure to captivate readers—from the humorously annotated examples, to the Fireside Chats, where the abstract class and interface butt heads in a heated argument! For anyone new to programming, there’s no better way to dive in.”

— **Joseph Albahari, C# Design Architect at Egton Medical Information Systems, the UK’s largest primary healthcare software supplier, co-author of *C# 3.0 in a Nutshell***

“[Head First C#] was an easy book to read and understand. I will recommend this book to any developer wanting to jump into the C# waters. I will recommend it to the advanced developer that wants to understand better what is happening with their code. [I will recommend it to developers who] want to find a better way to explain how C# works to their less-seasoned developer friends.”

— **Giuseppe Turitto, C# and ASP.NET developer for Cornwall Consulting Group**

“Andrew and Jenny have crafted another stimulating Head First learning experience. Grab a pencil, a computer, and enjoy the ride as you engage your left brain, right brain, and funny bone.”

— **Bill Mietelski, Software Engineer**

“Going through this Head First C# book was a great experience. I have not come across a book series which actually teaches you so well... This is a book I would definitely recommend to people wanting to learn C#”

— **Krishna Pala, MCP**

Praise for other *Head First* books

“Kathy and Bert’s *Head First Java* transforms the printed page into the closest thing to a GUI you’ve ever seen. In a wry, hip manner, the authors make learning Java an engaging ‘what’re they gonna do next?’ experience.”

—**Warren Keuffel, Software Development Magazine**

“Beyond the engaging style that drags you forward from know-nothing into exalted Java warrior status, *Head First Java* covers a huge amount of practical matters that other texts leave as the dreaded “exercise for the reader...” It’s clever, wry, hip and practical—there aren’t a lot of textbooks that can make that claim and live up to it while also teaching you about object serialization and network launch protocols. ”

—**Dr. Dan Russell, Director of User Sciences and Experience Research
IBM Almaden Research Center (and teaches Artificial Intelligence at Stanford University)**

“It’s fast, irreverent, fun, and engaging. Be careful—you might actually learn something!”

—**Ken Arnold, former Senior Engineer at Sun Microsystems
Co-author (with James Gosling, creator of Java), *The Java Programming Language***

“I feel like a thousand pounds of books have just been lifted off of my head.”

—**Ward Cunningham, inventor of the Wiki and founder of the Hillside Group**

“Just the right tone for the geeked-out, casual-cool guru coder in all of us. The right reference for practical development strategies—gets my brain going without having to slog through a bunch of tired stale professor-speak.”

—**Travis Kalanick, Founder of Scour and Red Swoosh
Member of the MIT TR100**

“There are books you buy, books you keep, books you keep on your desk, and thanks to O’Reilly and the Head First crew, there is the penultimate category, Head First books. They’re the ones that are dog-eared, mangled, and carried everywhere. Head First SQL is at the top of my stack. Heck, even the PDF I have for review is tattered and torn.”

— **Bill Sawyer, ATG Curriculum Manager, Oracle**

“This book’s admirable clarity, humor and substantial doses of clever make it the sort of book that helps even non-programmers think well about problem-solving.”

— **Cory Doctorow, co-editor of Boing Boing
Author, *Down and Out in the Magic Kingdom*
and *Someone Comes to Town, Someone Leaves Town***

Praise for other *Head First* books

“I received the book yesterday and started to read it...and I couldn’t stop. This is definitely très ‘cool.’ It is fun, but they cover a lot of ground and they are right to the point. I’m really impressed.”

— **Erich Gamma, IBM Distinguished Engineer, and co-author of *Design Patterns***

“One of the funniest and smartest books on software design I’ve ever read.”

— **Aaron LaBerge, VP Technology, ESPN.com**

“What used to be a long trial and error learning process has now been reduced neatly into an engaging paperback.”

— **Mike Davidson, CEO, Newsvine, Inc.**

“Elegant design is at the core of every chapter here, each concept conveyed with equal doses of pragmatism and wit.”

— **Ken Goldstein, Executive Vice President, Disney Online**

“I ♥ Head First HTML with CSS & XHTML—it teaches you everything you need to learn in a ‘fun coated’ format.”

— **Sally Applin, UI Designer and Artist**

“Usually when reading through a book or article on design patterns, I’d have to occasionally stick myself in the eye with something just to make sure I was paying attention. Not with this book. Odd as it may sound, this book makes learning about design patterns fun.

“While other books on design patterns are saying ‘Buehler... Buehler... Buehler...’ this book is on the float belting out ‘Shake it up, baby!’”

— **Eric Wuehler**

“I literally love this book. In fact, I kissed this book in front of my wife.”

— **Satish Kumar**

Other related books from O'Reilly

Programming C# 3.0

C# 3.0 in a Nutshell

C# 3.0 Cookbook™

C# 3.0 Design Patterns

C# Essentials

C# Language Pocket Reference

Other books in O'Reilly's *Head First* series

Head First Java

Head First Object-Oriented Analysis and Design (OOA&D)

Head Rush Ajax

Head First HTML with CSS and XHTML

Head First Design Patterns

Head First Servlets and JSP

Head First EJB

Head First PMP

Head First SQL

Head First Software Development

Head First JavaScript

Head First Ajax

Head First Statistics

Head First Physics (2008)

Head First Programming (2008)

Head First Ruby on Rails (2008)

Head First PHP & MySQL (2008)

Head First C#

Wouldn't it be dreamy
if there was a *C#* book that
was more fun than endlessly
debugging code? It's probably
nothing but a fantasy...



Andrew Stellman
Jennifer Greene

O'REILLY®

Beijing • Cambridge • Köln • Sebastopol • Taipei • Tokyo

Head First C#

by Andrew Stellman and Jennifer Greene

Copyright © 2008 O'Reilly Media, Inc. All rights reserved.

Printed in the United States of America.

Published by O'Reilly Media, Inc., 1005 Gravenstein Highway North, Sebastopol, CA 95472.

O'Reilly Media books may be purchased for educational, business, or sales promotional use. Online editions are also available for most titles (*safari.oreilly.com*). For more information, contact our corporate/institutional sales department: (800) 998-9938 or *corporate@oreilly.com*.

Series Creators: Kathy Sierra, Bert Bates
Series Editor: Brett D. McLaughlin
Design Editor: Louise Barr
Cover Designers: Louise Barr, Steve Fehler
Production Editor: Sanders Kleinfeld
Proofreader: Colleen Gorman
Indexer: Julie Hawks
Page Viewers: Quentin the whippet and Tequila the pomeranian

Printing History:

November 2007: First Edition.



The O'Reilly logo is a registered trademark of O'Reilly Media, Inc. The *Head First* series designations, *Head First C#*, and related trade dress are trademarks of O'Reilly Media, Inc.

Microsoft, Windows, Visual Studio, MSDN, the .NET logo, Visual Basic and Visual C# are registered trademarks of Microsoft Corporation.

Many of the designations used by manufacturers and sellers to distinguish their products are claimed as trademarks. Where those designations appear in this book, and O'Reilly Media, Inc., was aware of a trademark claim, the designations have been printed in caps or initial caps.

While every precaution has been taken in the preparation of this book, the publisher and the authors assume no responsibility for errors or omissions, or for damages resulting from the use of the information contained herein.

No bees, space aliens, or comic book heroes were harmed in the making of this book.



This book uses RepKover™, a durable and flexible lay-flat binding.

ISBN: 978-0-596-51482-2

[M]

[9/08]

This book is dedicated to the loving memory of Sludgie the Whale, who swam to Brooklyn on April 17, 2007.

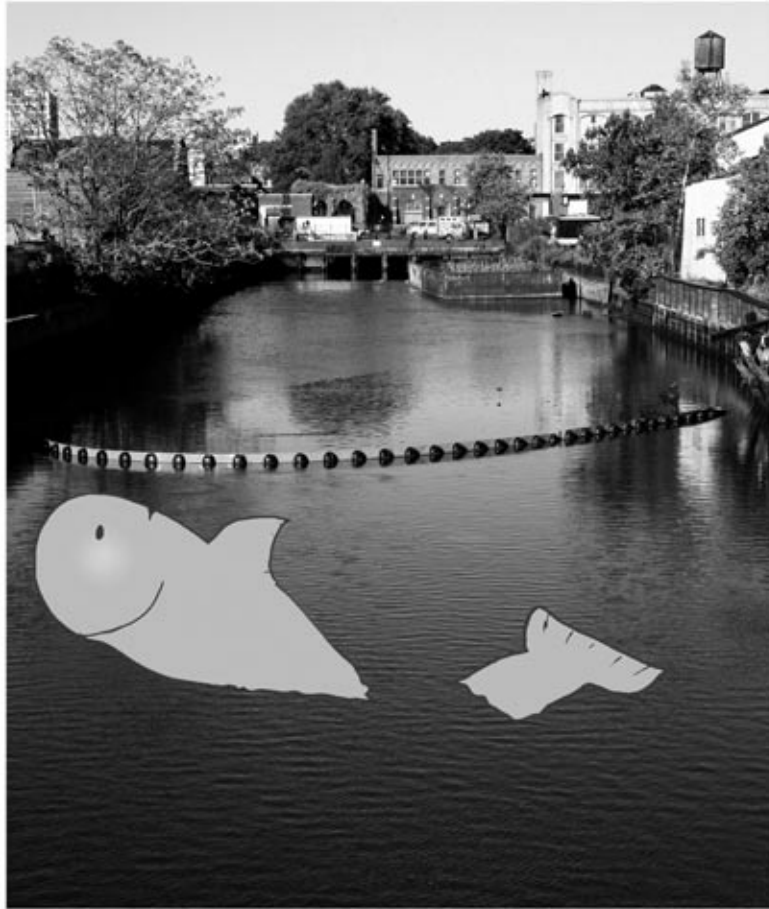

*You were only in our canal for a day,
but you'll be in our hearts forever.*

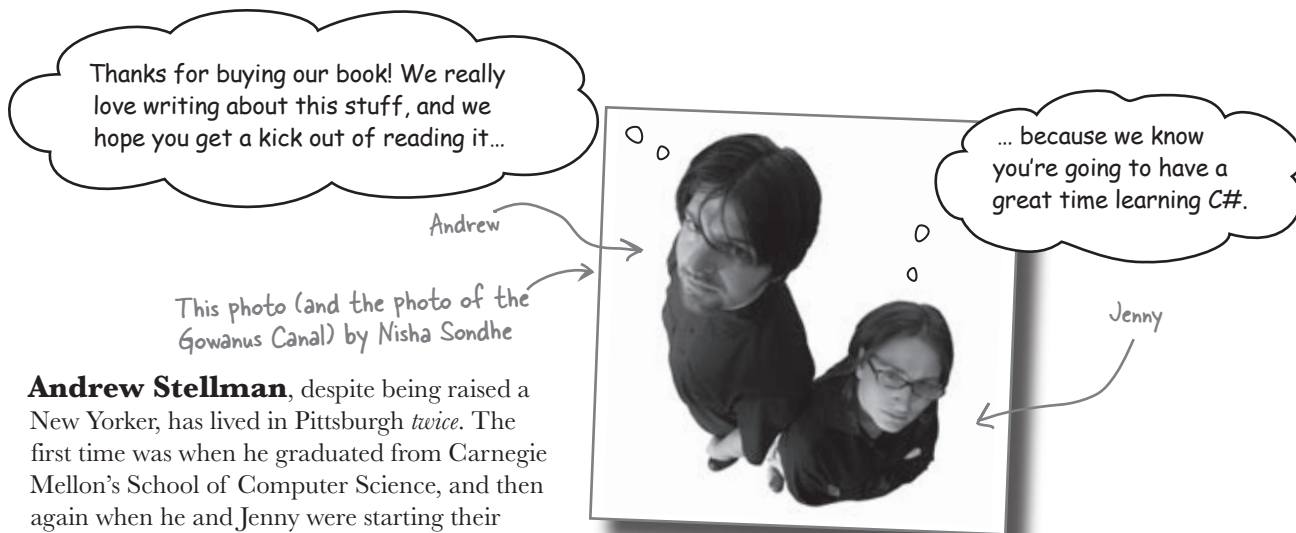

Andrew Stellman, despite being raised a New Yorker, has lived in Pittsburgh *twice*. The first time was when he graduated from Carnegie Mellon's School of Computer Science, and then again when he and Jenny were starting their consulting business and writing their first book for O'Reilly.

When he moved back to his hometown, his first job after college was as a programmer at EMI-Capitol Records—which actually made sense, since he went to LaGuardia High School of Music and Art and the Performing Arts to study cello and jazz bass guitar. He and Jenny first worked together at that same financial software company, where he was managing a team of programmers. He's had the privilege of working with some pretty amazing programmers over the years, and likes to think that he's learned a few things from them.

When he's not writing books, Andrew keeps himself busy writing useless (but fun) software, playing music (but video games even more), studying taiji and aikido, having a girlfriend named Lisa, and owning a pomeranian.

Jenny and Andrew have been building software and writing about software engineering together since they first met in 1998. Their first book, *Applied Software Project Management*, was published by O'Reilly in 2005. They published their first book in the Head First series, *Head First PMP*, in 2007.

They founded Stellman & Greene Consulting in 2003 to build a really neat software project for scientists studying herbicide exposure in Vietnam vets. When they're not building software or writing books, they do a lot of speaking at conferences and meetings of software engineers, architects and project managers.

Check out their blog, *Building Better Software*: <http://www.stellman-greene.com>

Jennifer Greene studied philosophy in college but, like everyone else in the field, couldn't find a job doing it. Luckily, she's a great software tester, so she started out doing it at an online service, and that's the first time she really got a good sense of what project management was.

She moved to New York in 1998 to test software at a financial software company. She managed a team of testers at a really cool startup that did artificial intelligence and natural language processing.

Since then, she's traveled all over the world to work with different software teams and build all kinds of cool projects.

She loves traveling, watching Bollywood movies, reading the occasional comic book, waiting for her Xbox to be repaired, drinking carloads of carbonated beverages, and owning a whipplet.

Table of Contents (Summary)

	Intro	xxix
1	Get productive with C#: <i>Visual Applications, in 10 minutes or less</i>	1
2	It's All Just Code: <i>Under the hood</i>	43
3	Objects Get Oriented: <i>Making code make sense</i>	85
4	Types and References: <i>It's 10:00. Do you know where your data is?</i>	123
	C# Lab 1: <i>A Day at the Races</i>	163
5	Encapsulation: <i>Keep your privates... private</i>	173
6	Inheritance: <i>Your object's family tree</i>	205
7	Interfaces and abstract classes: <i>Making classes keep their promises</i>	251
8	Enums and collections: <i>Storing lots of data</i>	309
	C# Lab 2: <i>The Quest</i>	363
9	Reading and writing files: <i>Save the byte array, save the world</i>	385
10	Exception handling: <i>Putting Out Fires Gets Old</i>	439
11	Events and delegates: <i>What Your Code Does When You're Not Looking</i>	483
12	Review and preview: <i>Knowledge, Power, and Building Cool Stuff</i>	515
13	Controls and graphics: <i>Make it pretty</i>	563
14	Captain Amazing: <i>The Death of the Object</i>	621
15	LINQ: <i>Get control of your data</i>	653
	C# Lab 3: <i>Invaders</i>	681
i	Leftovers: <i>The top 5 things we wanted to include in this book</i>	703

Table of Contents (the real thing)

Intro

Your brain on C#. You're sitting around trying to *learn* something, but your *brain* keeps telling you all that learning *isn't important*. Your brain's saying, "Better leave room for more important things, like which wild animals to avoid and whether nude archery is a bad idea." So how *do* you trick your brain into thinking that your life really depends on learning C#?

Who is this book for?	xxx
We know what you're thinking	xxxii
Metacognition	xxxiii
Bend your brain into submission	xxxv
What you need for this book	xxxvi
Read me	xxxii
The technical review team	xxxiv
Acknowledgments	xxxv

get productive with C#

1

Visual Applications, in 10 minutes or less

Want to build great programs really fast?

With C#, you've got a **powerful programming language** and a **valuable tool** at your fingertips. With the **Visual Studio IDE**, you'll never have to spend hours writing obscure code to get a button working again. Even better, you'll be able to **focus on getting your work done**, rather than remembering which method parameter was for the *name* for a button, and which one was for its *label*. Sound appealing? Turn the page, and let's get programming.

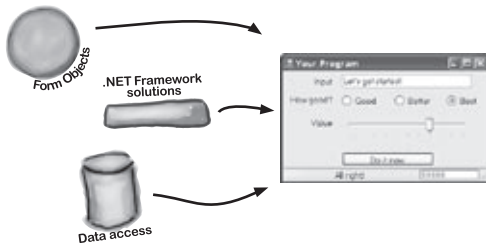

Why you should learn C#	2
C# and the Visual Studio IDE make lots of things easy	3
Help the CEO go paperless	4
Get to know your users' needs before you start building your program	5
Here's what you're going to build	6
What you do in Visual Studio...	8
What Visual Studio does for you...	8
Develop the user interface	12
Visual Studio, behind the scenes	14
Add to the auto-generated code	15
You can already run your application	16
We need a database to store our information	18
Creating the table for the Contact List	20
The blanks on contact card are columns in our People table	22
Finish building the table	25
Diagram your data so your application can access it	26
Insert your card data into the database	28
Connect your form to your database objects with a data source	30
Add database-driven controls to your form	32
Good apps are intuitive to use	34
How to turn YOUR application into EVERYONE'S application	37
Give your users the application	38
You're NOT done: test your installation	39
You built a complete data-driven application	40

2

it's all just code Under the Hood

You're a programmer, not just an IDE-user.

You can get a lot of work done using the IDE. But there's only so far it can take you. Sure, there are a lot of **repetitive tasks** that you do when you build an application. And the IDE is great at doing those things for you. But working with the IDE is *only the beginning*. You can get your programs to do so much more—and **writing C# code** is how you do it. Once you get the hang of coding, there's *nothing* your programs can't do.

When you're doing this...	44
...the IDE does this	45
Where programs come from	46
The IDE helps you code	48
When you change things in the IDE, you're also changing your code	50
Anatomy of a program	52
Your program knows where to start	54
You can change your program's entry point	56
Two classes can be in the same namespace	61
Your programs use variables to work with data	62
C# uses familiar math symbols	64
Loops perform an action over and over again	65
Time to start coding	66
if/else statements make decisions	67
Set up conditions and see if they're true	68

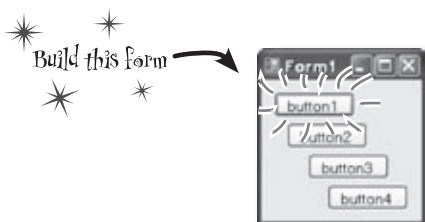

Every time you make a new program, you define a namespace for it so that its code is separate from the .NET Framework classes.

A class contains a piece of your program (although some very small programs can have just one class).

A class has one or more methods. Your methods always have to live inside a class. And methods are made up of statements – like the ones you've already seen.

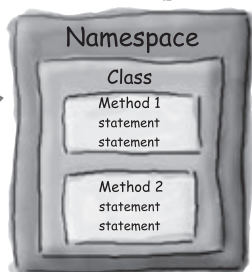

objects get oriented

Making Code Make Sense

3

Every program you write solves a problem.

When you're building a program, it's always a good idea to start by thinking about what *problem* your program's supposed to solve. That's why **objects** are really useful. They let you structure your code based on the problem it's solving, so that you can spend your time *thinking about the problem* you need to work on rather than getting bogged down in the mechanics of writing code. When you use objects right, you end up with code that's *intuitive* to write, and easy to read and change.

How Mike thinks about his problems	86
How Mike's car navigation system thinks about his problems	87
Mike's Navigator class has methods to set and modify routes	88
Use what you've learned to build a simple application	89
Mike gets an idea	90
Mike can use objects to solve his problem	91
You use a class to build an object	92
When you create a new object from a class, it's called an instance of that class	93
A better solution... brought to you by objects!	94
An instance uses fields to keep track of things	98
Let's create some instances!	99
Thanks for the memory	100
What's on your program's mind	101
You can use class and method names to make your code intuitive	102
Give your classes a natural structure	104
Class diagrams help you organize your classes so they make sense	106
Build a class to work with some guys	110
Create a project for your guys	111
Build a form to interact with the guys	112
There's an even easier way to initialize objects	115
A few ideas for designing intuitive classes	116

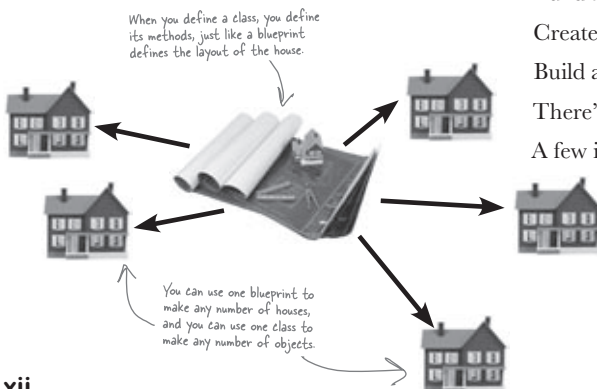
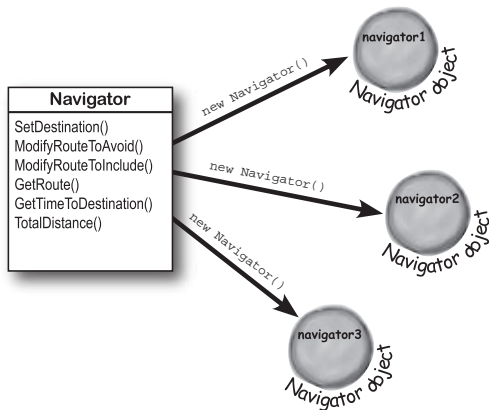

types and references

4

It's 10:00. Do you know where your data is?

Data type, database, Lieutenant Commander Data...

it's all important stuff. Without data, your programs are useless. You need **information** from your users, and you use that to look up or produce new information, to give back to them. In fact, almost everything you do in programming involves **working with data** in one way or another. In this chapter, you'll learn the ins and outs of C#'s **data types**, how to work with data in your program, and even figure out a few dirty secrets about **objects** (*psstt... objects are data, too*).

The variable's type determines what kind of data it can store	124
A variable is like a data to-go cup	126
10 pounds of data in a 5 pound bag	127
Even when a number is the right size, you can't just assign it to any variable	128
When you cast a value that's too big, C# will adjust it automatically	129
C# does some casting automatically	130
When you call a method, the variables must match the types of the parameters	131
Combining = with an operator	136
Objects use variables, too	137
Refer to your objects with reference variables	138
References are like labels for your object	139
If there aren't any more references, your object gets garbage collected	140
Multiple references and their side effects	142
Two references means TWO ways to change an object's data	147
A special case: arrays	148
Arrays can contain a bunch of reference variables, too	149
Welcome to Sloppy Joe's Budget House o' Discount Sandwiches!	150
Objects use references to talk to each other	152
Where no object has gone before	153

```
Dog fido;
Dog lucky = new Dog();
```



```
fido = new Dog();
```

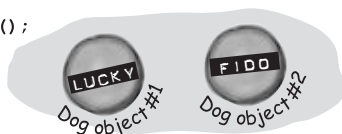

```
lucky = null;
```



C# Lab 1

A Day at the Races

Joe, Bob, and Al love going to the track, but they're tired of losing all their money. They need you to build a simulator for them so they can figure out winners before they lay their money down. And, if you do a good job, they'll cut you in on their profits.

The Spec: Build a Racetrack Simulator	164
The Finished Product	172

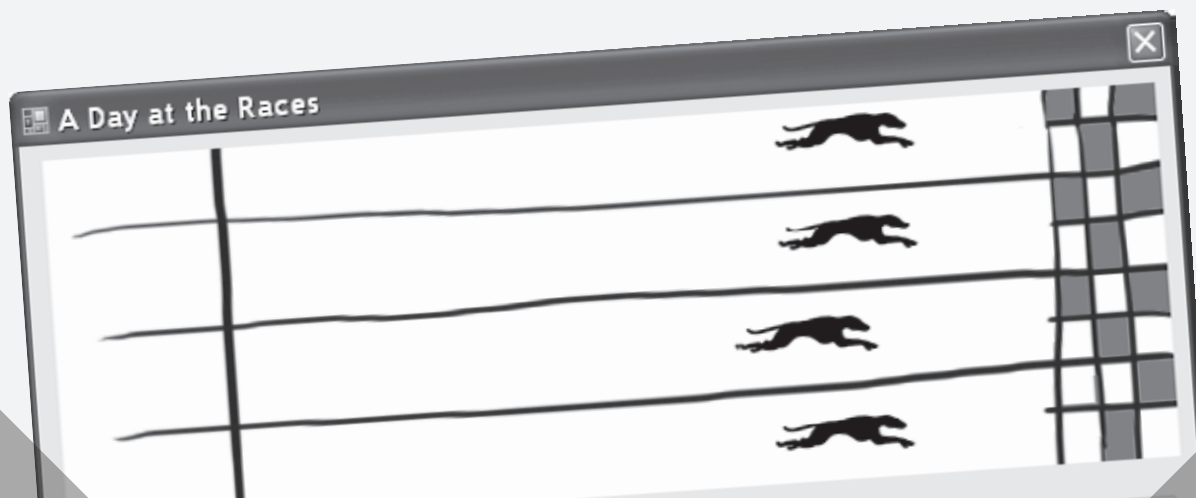

encapsulation

5

Keep your privates... private

Ever wished for a little more privacy?

Sometimes your objects feel the same way. Just like you don't want anybody you don't trust reading your journal, or paging through your bank statements, good objects don't let **other** objects go poking around their properties. In this chapter, you're going to learn about the power of **encapsulation**. You'll **make your object's data private**, and add methods to **protect how that data is accessed**.

Kathleen is an event planner	174
What does the estimator do?	175
Kathleen's Test Drive	180
Each option should be calculated individually	182
It's easy to accidentally misuse your objects	184
Encapsulation means keeping some of the data in a class private	185
Use encapsulation to control access to your class's methods and fields	186
But is the realName field REALLY protected?	187
Private fields and methods can only be accessed from inside the class	188
A few ideas for encapsulating classes	191
Encapsulation keeps your data pristine	192
Properties make encapsulation easier	193
Build an application to test the Farmer class	194
Use automatic properties to finish the class	195
What if we want to change the feed multiplier?	196
Use a constructor to initialize private fields	197

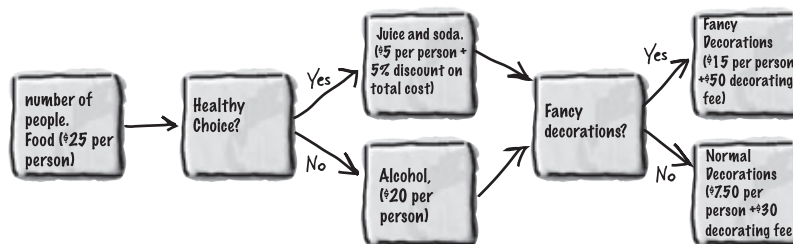

inheritance

6

Your object's family tree

Sometimes you *DO* want to be just like your parents.

Ever run across an object that **almost** does exactly what you want **your** object to do? Found yourself wishing that if you could just **change a few things**, that object would be perfect? Well that's just one reason that **inheritance** is one of the most powerful concepts and techniques in the C# language. Before you're through this chapter, you'll learn how to **subclass** an object to get its behavior, but keep the **flexibility** to make changes to that behavior. You'll **avoid duplicate code**, **model the real world** more closely, and end up with code that's **easier to maintain**.

Kathleen does birthday parties, too	206
We need a BirthdayParty class	207
One more thing... can you add a \$100 fee for parties over 12?	213
When your classes use inheritance, you only need to write your code once	214
Build up your class model by starting general and getting more specific	215
How would you design a zoo simulator?	216
Use inheritance to avoid duplicate code in subclasses	217
Different animals make different noises	218
Think about how to group the animals	219
Create the class hierarchy	220
Every subclass extends its base class	221
Use a colon to inherit from a base class	222
We know that inheritance adds the base class fields, properties, and methods to the subclass...	225
A subclass can override methods to change or replace methods it inherited	226
Any place where you can use a base class, you can use one of its subclasses instead	227
A subclass can access its base class using the base keyword	232
When a base class has a constructor, your subclass needs one too	233
Now you're ready to finish the job for Kathleen!	234
Build a beehive management system	239
First you'll build the basic system	240
Use inheritance to extend the bee management system	245



interfaces and abstract classes

Making classes keep their promises

7

Actions speak louder than words.

Sometimes you need to group your objects together based on the **things they can do** rather than the classes they inherit from. That's where **interfaces** come in—they let you work with any class that can do the job. But with **great power comes great responsibility**, and any class that implements an interface must promise to **fulfill all of its obligations...** or the compiler will break their kneecaps, see?

* Inheritance

Let's get back to bee-sics 252

We can use inheritance to create classes for different types of bees 253

An interface tells a class that it must implement certain methods and properties 254

Use the interface keyword to define an interface 255

Get a little practice using interfaces 256

Now you can create an instance of NectarStinger that does both jobs 257

Classes that implement interfaces have to include ALL of the interface's methods 258

You can't instantiate an interface, but you can reference an interface 260

Interface references work just like object references 261

You can find out if a class implements a certain interface with "is" 262

Interfaces can inherit from other interfaces 263

The RoboBee 4000 can do a worker bee's job without using valuable honey 264

is tells you what an object implements, as tells the compiler how to treat your object 265

A CoffeeMaker is also an Appliance 266

Upcasting works with both objects and interfaces 267

Downcasting lets you turn your appliance back into a coffee maker 268

Upcasting and downcasting work with interfaces, too 269

There's more than just public and private 273

Access modifiers change scope 274

Some classes should never be instantiated 277

An abstract class is like a cross between a class and an interface 278

Like we said, some classes should never be instantiated 280

An abstract method doesn't have a body 281

Polymorphism means that one object can take many different forms 289

Abstraction

Encapsulation

Polymorphism

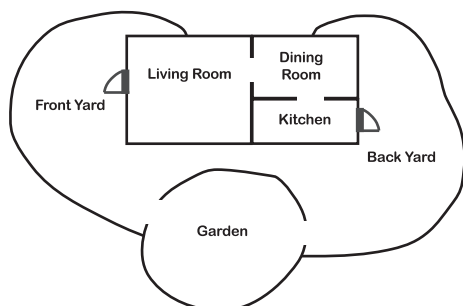
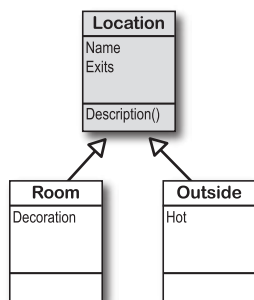

enums and collections

Storing lots of data

8

When it rains, it pours.

In the real world, you don't get to handle your data in tiny little bits and pieces. No, your data's going to come at you in **loads, piles and bunches**. You'll need some pretty powerful tools to organize all of it, and that's where **collections** come in. They let you **store, sort and manage** all the data that your programs need to pore through. That way you can think about writing programs to work with your data, and let the collections worry about keeping track of it for you.

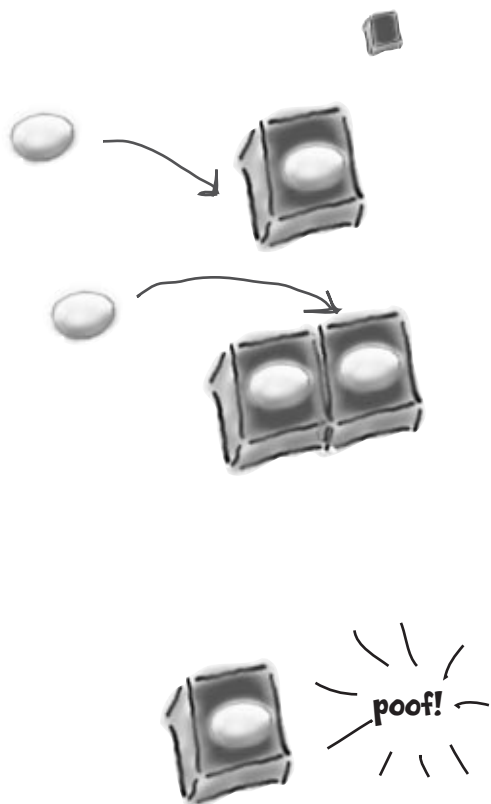

Strings don't always work for storing categories of data	310
Enums let you enumerate a set of valid values	311
Enums let you represent numbers with names	312
We could use an array to create a deck of cards...	315
Arrays are hard to work with	316
Lists make it easy to store collections of... anything	317
Lists are more flexible than arrays	318
Lists shrink and grow dynamically	321
List objects can store any type	322
Collection initializers work just like object initializers	326
Let's create a list of Ducks	327
Lists are easy, but SORTING can be tricky	328
Two ways to sort your ducks	329
Use IComparer to tell your List how to sort	330
Create an instance of your comparer object	331
IComparer can do complex comparisons	332
Use a dictionary to store keys and values	335
The Dictionary Functionality Rundown	336
Your key and value can be different types, too	337
You can build your own overloaded methods	343
And yet MORE collection types...	355
A queue is FIFO — First In, First Out	356
A stack is LIFO — Last In, First Out	357

C# Lab 2

The Quest

Your job is to build an adventure game where a mighty adventurer is on a quest to defeat level after level of deadly enemies. You'll build a turn-based system, which means the player makes one move and then the enemies make one move. The player can move or attack, and then each enemy gets a chance to move and attack. The game keeps going until the player either defeats all the enemies on all seven levels or dies.

The spec: build an adventure game	364
The fun's just beginning!	484

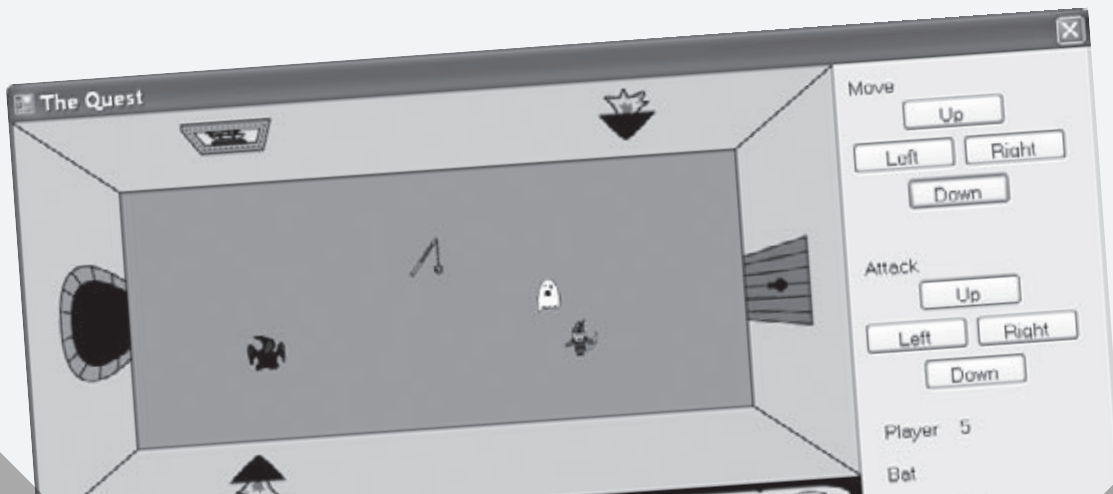

reading and writing files

Save the byte array, save the world

9

Sometimes it pays to be a little persistent.

So far, all of your programs have been pretty short-lived. They fire up, run for a while, and shut down. But that's not always enough, especially when you're dealing with important information. You need to be able to **save your work**. In this chapter, we'll look at how to **write data to a file**, and then how to **read that information back in** from a file. You'll learn about the .NET **stream classes**, and also take a look at the mysteries of **hexadecimal** and **binary**.

C# uses streams to read and write data	386
Different streams read and write different things	387
A FileStream writes bytes to a file	388
Reading and writing takes two objects	393
Data can go through more than one stream	394
Use built-in objects to pop up standard dialog boxes	397
Dialog boxes are objects, too	399
Use the built-in File and Directory classes to work with files and directories	400
Use File Dialogs to open and save files	403
IDisposable makes sure your objects are disposed properly	405
Avoid file system errors with using statements	406
Writing files usually involves making a lot of decisions	412
Use a switch statement to choose the right option	413
Add an overloaded Deck() constructor that reads a deck of cards in from a file	415
What happens to an object when it's serialized?	417
But what exactly IS an object's state? What needs to be saved?	418
When an object is serialized, all of the objects it refers to get serialized too...	419
Serialization lets you read or write a whole object all at once	420
If you want your class to be serializable, mark it with the [Serializable] attribute	421
.NET converts text to Unicode automatically	425
C# can use byte arrays to move data around	426
Use a BinaryWriter to write binary data	427
You can read and write serialized files manually, too	429
StreamReader and StreamWriter will do just fine	433

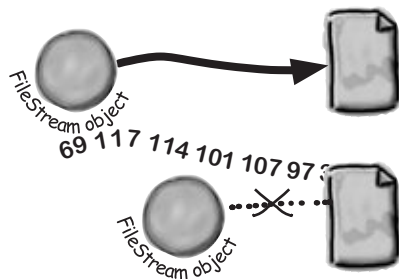
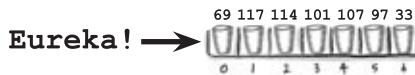
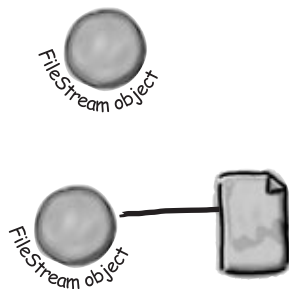

exception handling

Putting out fires gets old

10

Programmers aren't meant to be firefighters.

You've worked your tail off, waded through technical manuals and a few engaging Head First books, and you've reached the pinnacle of your profession: **master programmer**. But you're still getting pages from work because **your program crashes**, or **doesn't behave like it's supposed to**. Nothing pulls you out of the programming groove like having to fix a strange bug . . . but with **exception handling**, you can write code to **deal with problems** that . . . come up. Better yet, you can even react to those problems, and **keep things running**.

Brian needs his excuses to be mobile	440
When your program throws an exception, .NET generates an Exception object.	444
Brian's code did something unexpected	446
All exception objects inherit from Exception	448
The debugger helps you track down and prevent exceptions in your code	449
Use the IDE's debugger to ferret out exactly what went wrong in the excuse manager	450
Uh-oh—the code's still got problems...	453
Handle exceptions with try and catch	455
What happens when a method you want to call is risky?	456
Use the debugger to follow the try/catch flow	458
If you have code that ALWAYS should run, use a finally block	460
Use the Exception object to get information about the problem	465
Use more than one catch block to handle multiple types of exceptions	466
One class throws an exception, another class catches the exception	467
Bees need an OutOfHoney exception	468
An easy way to avoid a lot of problems: using gives you try and finally for free	471
Exception avoidance: implement IDisposable to do your own clean up	472
The worst catch block EVER: comments	474
Temporary solutions are okay (temporarily)	475
A few simple ideas for exception handling	476
Brian finally gets his vacation...	481



11

events and delegates

What your code does when you're not looking

Your objects are starting to think for themselves.

You can't always control what your objects are doing. Sometimes things...happen. And when they do, you want your objects to be smart enough to **respond to anything** that pops up. And that's what events are all about. One object *publishes* an event, other objects *subscribe*, and everyone works together to keep things moving. Which is great, until you've got too many objects responding to the same event. And that's when **callbacks** will come in handy.

Ever wish your objects could think for themselves?	484
But how does an object KNOW to respond?	484
When an EVENT occurs... objects listen	485
One object raises its event, others listen for it...	486
Then, the other objects handle the event	487
Connecting the dots	488
The IDE creates event handlers for you automatically	492
The forms you've been building all use events	498
Connecting event senders with event receivers	500
A delegate STANDS IN for an actual method	501
Delegates in action	502
Any object can subscribe to a public event...	505
Use a callback instead of an event to hook up exactly one object to a delegate	507
Callbacks use delegates, but NOT events	508

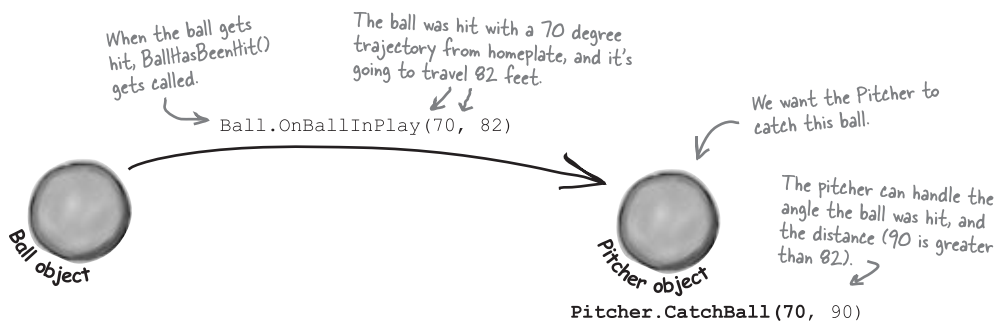

review and preview

12

Knowledge, power, and building cool stuff

Learning's no good until you BUILD something.

Until you've actually written working code, it's hard to be sure if you really *get* some of the tougher concepts in C#. In this chapter, we're going to learn about some new odds and ends: **timers** and dealing with collections using **LINQ** (to name a couple). We're also going to build phase I of a **really complex application**, and make sure you've got a good handle on what you've already learned from earlier chapters. So buckle up... it's time to build some **cool software**.

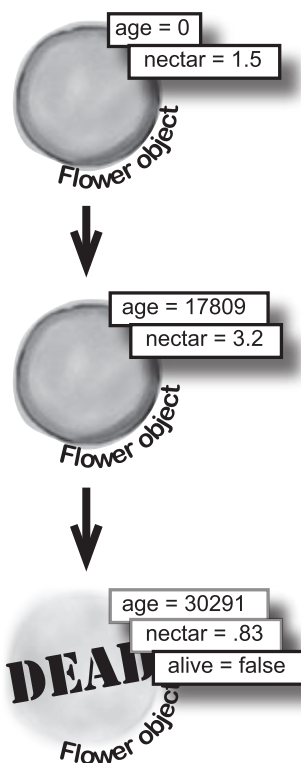
Life and death of a flower

You've come a long way, baby	516
We've also become beekeepers	517
The beehive simulator architecture	518
Building the beehive simulator	519
Life and death of a flower	523
Now we need a Bee class	524
Filling out the Hive class	532
The hive's Go() method	533
We're ready for the World	534
We're building a turn-based system	535
Giving the bees behavior	542
The main form tells the world to Go()	544
We can use World to get statistics	545
Timers fire events over and over again	546
The timer's using a delegate behind the scenes	547
Let's work with groups of bees	554
A collection collects... DATA	555
LINQ makes working with data in collections and databases easy	557

13

controls and graphics

Make it pretty

Sometimes you have to take graphics into your own hands.

We've spent a lot of time on relying on controls to handle everything visual in our applications. But sometimes that's not enough—like when you want to **animate a picture**. And once you get into animation, you'll end up **creating your own controls** for your .NET programs, maybe adding a little **double buffering**, and even **drawing directly onto your forms**. It all begins with the **Graphics** object, **Bitmaps**, and a determination to not accept the graphics status quo.

You've been using controls all along to interact with your programs	564
Form controls are just objects	565
Add a renderer to your architecture	568
Controls are well-suited for visual display elements	570
Build your first animated control	573
Your controls need to dispose their controls, too!	577
A UserControl is an easy way to build a control	578
Add the hive and field forms to the project	582
Build the Renderer	583
Let's take a closer look at those performance issues	590
You resized your Bitmaps using a Graphics object	592
Your image resources are stored in Bitmap objects	593
Use System.Drawing to TAKE CONTROL of graphics yourself	594
A 30-second tour of GDI+ graphics	595
Use graphics to draw a picture on a form	596
Graphics can fix our transparency problem...	601
Use the Paint event to make your graphics stick	602
A closer look at how forms and controls repaint themselves	605
Double buffering makes animation look a lot smoother	608
Double buffering is built into forms and controls	609
Use a Graphics object and an event handler for printing	614
PrintDocument works with the print dialog and print preview window objects	615

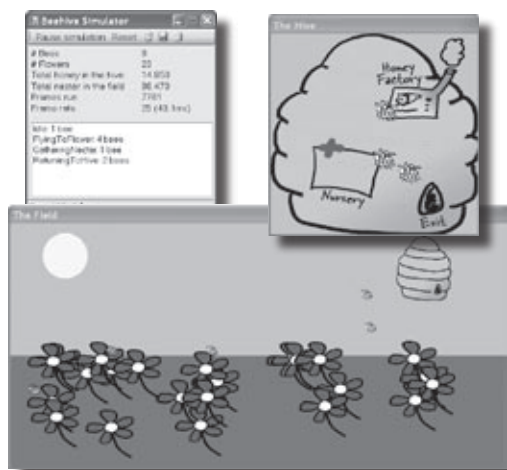

14

CAPTAIN AMAZING

THE DEATH OF THE OBJECT

Captain Amazing, Objectville's most amazing object pursues his arch-nemesis...	622
Your last chance to DO something... your object's finalizer	628
When EXACTLY does a finalizer run?	629
Dispose() works with using, finalizers work with garbage collection	630
Finalizers can't depend on stability	632
Make an object serialize itself in its Dispose()	633
Meanwhile, on the streets of Objectville...	636
A struct <i>looks</i> like an object...	637
..but <i>isn't</i> on the heap	637
Values get copied, references get assigned	638
Structs are value types; objects are reference types	639
The stack vs. the heap: more on memory	641
Captain Amazing... not so much	645
Extension methods add new behavior to EXISTING classes	646
Extending a fundamental type: string	648

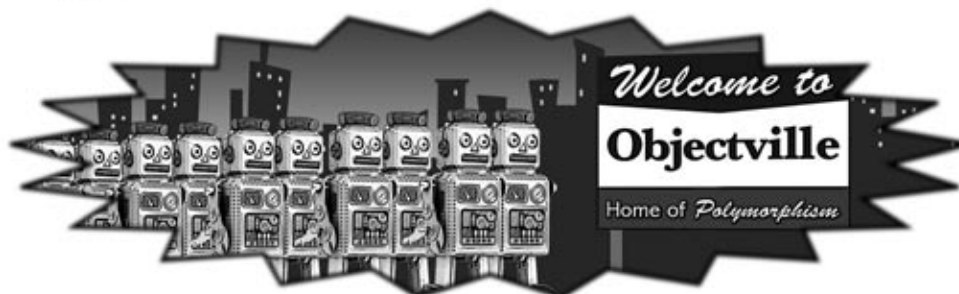

15

LINQ

Get control of your data

It's a data-driven world... you better know how to live in it.

Gone are the days when you could program for days, even weeks, without dealing with **loads of data**. But today, **everything is about data**. In fact, you'll often have to work with data from **more than one place**... and in more than one format. Databases, XML, collections from other programs... it's all part of the job of a good C# programmer. And that's where **LINQ** comes in. LINQ not only lets you **query data** in a simple, intuitive way, but it lets you **group data**, and **merge data from different data sources**.

An easy project...	654
...but the data's all over the place	655
LINQ can pull data from multiple sources	656
.NET collections are already set up for LINQ	657
LINQ makes queries easy	658
LINQ is simple, but your queries don't have to be	659
LINQ is versatile	662
LINQ can combine your results into groups	667
Combine Jimmy's values into groups	668
Use join to combine two collections into one query	671
Jimmy saved a bunch of dough	672
Connect LINQ to a SQL database	674
Use a join query to connect Starbuzz and Objectville	678

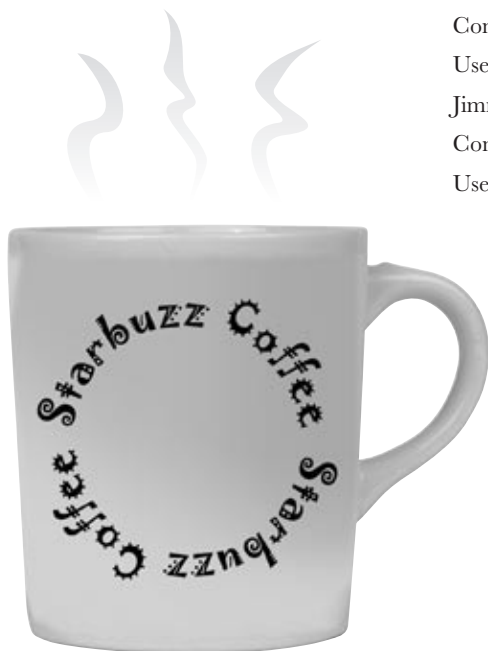

C# Lab 3

Invaders

In this lab you'll pay homage to one of the most popular, revered and replicated icons in video game history, a game that needs no further introduction. It's time to build Invaders.

The grandfather of video games	682
And yet there's more to do...	701



leftovers





The top 5 things we wanted to include in this book

The fun's just beginning!

We've shown you a lot of great tools to build some really **powerful software** with C#. But there's no way that we could include **every single tool, technology or technique** in this book—there just aren't enough pages. We had to make some *really tough choices* about what to include and what to leave out. Here are some of the topics that didn't make the cut. But even though we couldn't get to them, we still think that they're **important and useful**, and we wanted to give you a small head start with them.

#1 LINQ to XML	704
#2 Refactoring	706
#3 Some of our favorite Toolbox components	708
#4 Console Applications	710
#5 Windows Presentation Foundation	712
Did you know that C# and the .NET Framework can...	714

 backgroundWorker 1

 fileSystemWatcher 1

 performanceCounter 1



how to use this book

Intro

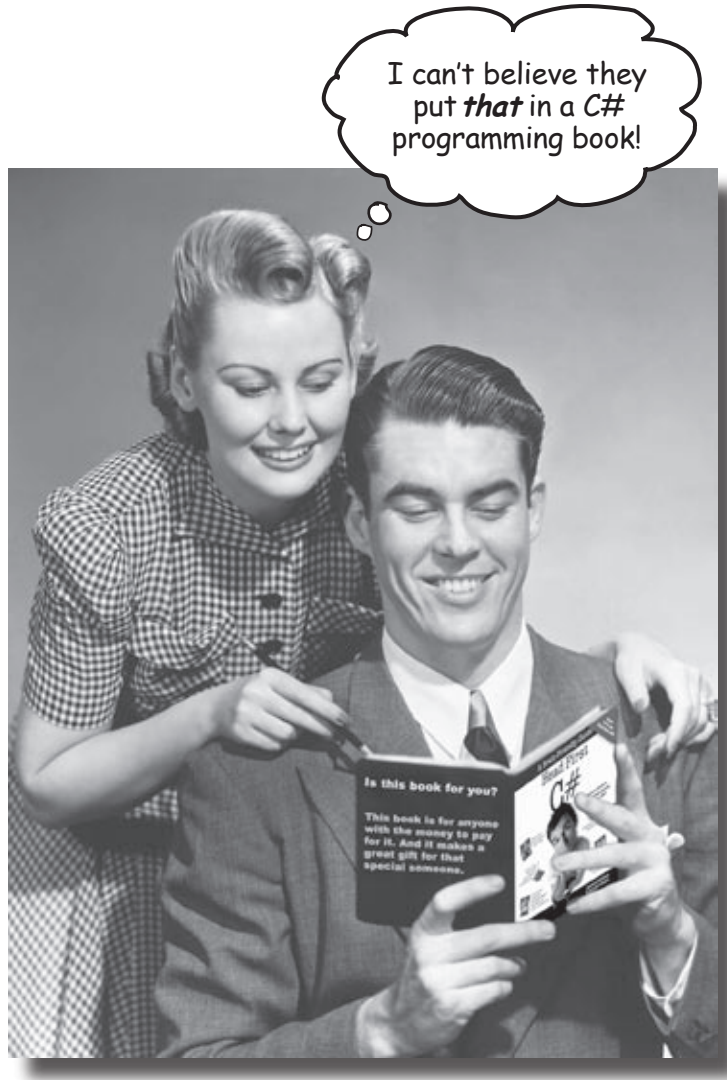

In this section, we answer the burning question:
"So why DID they put that in a C# programming book?"

Who is this book for?

If you can answer “yes” to all of these:

- ① Do you want to **learn C#**?
- ② Do you like to tinker—do you learn by doing, rather than just reading?
- ③ Do you prefer **stimulating dinner party conversation** to **dry, dull, academic lectures**?

this book is for you.

Who should probably back away from this book?

If you can answer “yes” to any of these:

- ① Does the idea of writing a lot of code make you bored and a little twitchy?
- ② Are you a kick-butt C++ or Java programmer looking for a reference book?
- ③ Are you **afraid to try something different**? Would you rather have a root canal than mix stripes with plaid? Do you believe that a technical book can't be serious if C# concepts are anthropomorphized?

this book is not for you.



[Note from marketing: this book is for anyone with a credit card.]

We know what you're thinking.

“How can *this* be a serious C# programming book?”

“What’s with all the graphics?”

“Can I actually *learn* it this way?”

And we know what your *brain* is thinking.

Your brain craves novelty. It’s always searching, scanning, *waiting* for something unusual. It was built that way, and it helps you stay alive.

So what does your brain do with all the routine, ordinary, normal things you encounter? Everything it *can* to stop them from interfering with the brain’s *real* job—recording things that *matter*. It doesn’t bother saving the boring things; they never make it past the “this is obviously not important” filter.

How does your brain *know* what’s important? Suppose you’re out for a day hike and a tiger jumps in front of you, what happens inside your head and body?

Neurons fire. Emotions crank up. *Chemicals surge*.

And that’s how your brain knows...

This must be important! Don’t forget it!

But imagine you’re at home, or in a library. It’s a safe, warm, tiger-free zone. You’re studying. Getting ready for an exam. Or trying to learn some tough technical topic your boss thinks will take a week, ten days at the most.

Just one problem. Your brain’s trying to do you a big favor. It’s trying to make sure that this *obviously* non-important content doesn’t clutter up scarce resources. Resources that are better spent storing the really *big* things. Like tigers. Like the danger of fire. Like how you should never have posted those “party” photos on your Facebook page.

And there’s no simple way to tell your brain, “Hey brain, thank you very much, but no matter how dull this book is, and how little I’m registering on the emotional Richter scale right now, I really *do* want you to keep this stuff around.”

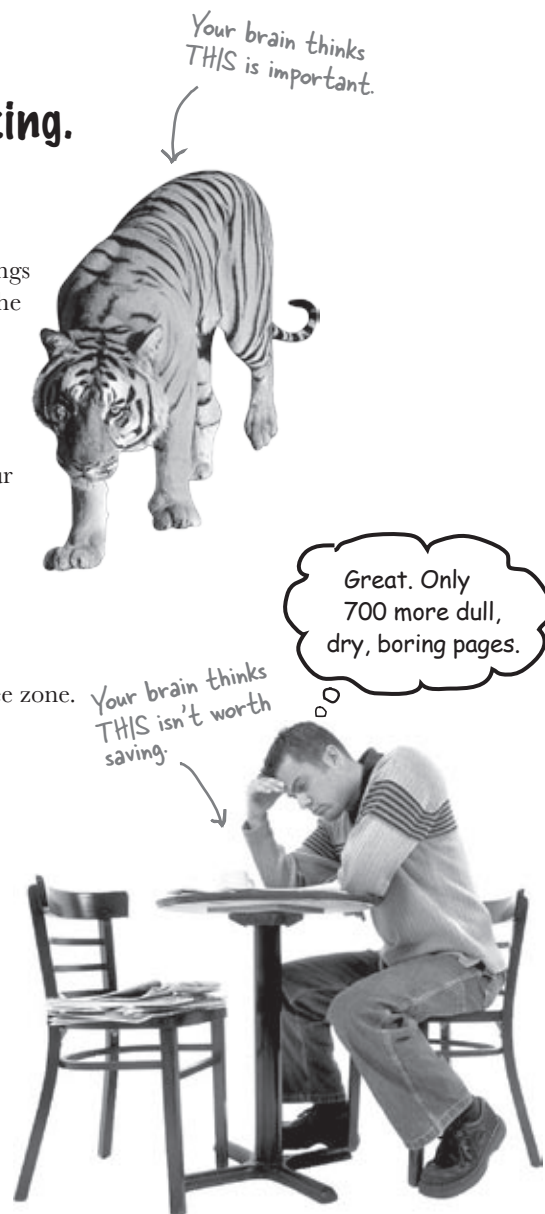

We think of a “Head First” reader as a learner.

So what does it take to *learn* something? First, you have to *get* it, then make sure you don't *forget* it. It's not about pushing facts into your head. Based on the latest research in cognitive science, neurobiology, and educational psychology, *learning* takes a lot more than text on a page. We know what turns your brain on.

Some of the Head First learning principles:

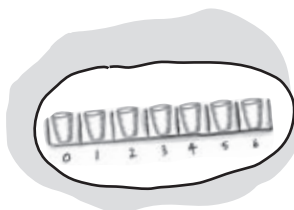

Make it visual. Images are far more memorable than words alone, and make learning much more effective (up to 89% improvement in recall and transfer studies). It also makes things more understandable. Put the words within or near the graphics they relate to, rather than on the bottom or on another page, and learners will be up to *twice* as likely to solve problems related to the content.

Use a conversational and personalized style. In recent studies, students performed up to 40% better on post-learning tests if the content spoke directly to the reader, using a first-person, conversational style rather than taking a formal tone. Tell stories instead of lecturing. Use casual language. Don't take yourself too seriously. Which would *you* pay more attention to: a stimulating dinner party companion, or a lecture?



Get the learner to think more deeply. In other words, unless you actively flex your neurons, nothing much happens in your head. A reader has to be motivated, engaged, curious, and inspired to solve problems, draw conclusions, and generate new knowledge. And for that, you need challenges, exercises, and thought-provoking questions, and activities that involve both sides of the brain and multiple senses.

Get—and keep—the reader's attention. We've all had the “I really want to learn this but I can't stay awake past page one” experience. Your brain pays attention to things that are out of the ordinary, interesting, strange, eye-catching, unexpected. Learning a new, tough, technical topic doesn't have to be boring. Your brain will learn much more quickly if it's not.



Touch their emotions. We now know that your ability to remember something is largely dependent on its emotional content. You remember what you care about. You remember when you *feel* something. No, we're not talking heart-wrenching stories about a boy and his dog. We're talking emotions like surprise, curiosity, fun, “what the...?”, and the feeling of “I Rule!” that comes when you solve a puzzle, learn something everybody else thinks is hard, or realize you know something that “I'm more technical than thou” Bob from engineering *doesn't*.



Metacognition: thinking about thinking

If you really want to learn, and you want to learn more quickly and more deeply, pay attention to how you pay attention. Think about how you think. Learn how you learn.

Most of us did not take courses on metacognition or learning theory when we were growing up. We were *expected* to learn, but rarely *taught* to learn.

But we assume that if you're holding this book, you really want to learn how to build programs in C#. And you probably don't want to spend a lot of time. If you want to use what you read in this book, you need to *remember* what you read. And for that, you've got to *understand* it. To get the most from this book, or *any* book or learning experience, take responsibility for your brain. Your brain on *this* content.

The trick is to get your brain to see the new material you're learning as Really Important. Crucial to your well-being. As important as a tiger. Otherwise, you're in for a constant battle, with your brain doing its best to keep the new content from sticking.

So just how *DO* you get your brain to treat C# like it was a hungry tiger?

There's the slow, tedious way, or the faster, more effective way. The slow way is about sheer repetition. You obviously know that you *are* able to learn and remember even the duller of topics if you keep pounding the same thing into your brain. With enough repetition, your brain says, "This doesn't *feel* important to him, but he keeps looking at the same thing *over* and *over* and *over*, so I suppose it must be."

The faster way is to do **anything that increases brain activity**, especially different *types* of brain activity. The things on the previous page are a big part of the solution, and they're all things that have been proven to help your brain work in your favor. For example, studies show that putting words *within* the pictures they describe (as opposed to somewhere else in the page, like a caption or in the body text) causes your brain to try to make sense of how the words and picture relate, and this causes more neurons to fire. More neurons firing = more chances for your brain to *get* that this is something worth paying attention to, and possibly recording.

A conversational style helps because people tend to pay more attention when they perceive that they're in a conversation, since they're expected to follow along and hold up their end. The amazing thing is, your brain doesn't necessarily *care* that the "conversation" is between you and a book! On the other hand, if the writing style is formal and dry, your brain perceives it the same way you experience being lectured to while sitting in a roomful of passive attendees. No need to stay awake.

But pictures and conversational style are just the beginning.



Here's what WE did:

We used **pictures**, because your brain is tuned for visuals, not text. As far as your brain's concerned, a picture really *is* worth a thousand words. And when text and pictures work together, we embedded the text *in* the pictures because your brain works more effectively when the text is *within* the thing the text refers to, as opposed to in a caption or buried in the text somewhere.

We used **redundancy**, saying the same thing in *different* ways and with different media types, and **multiple senses**, to increase the chance that the content gets coded into more than one area of your brain.

We used concepts and pictures in **unexpected** ways because your brain is tuned for novelty, and we used pictures and ideas with at least *some* **emotional content**, because your brain is tuned to pay attention to the biochemistry of emotions. That which causes you to *feel* something is more likely to be remembered, even if that feeling is nothing more than a little **humor, surprise, or interest**.

We used a personalized, **conversational style**, because your brain is tuned to pay more attention when it believes you're in a conversation than if it thinks you're passively listening to a presentation. Your brain does this even when you're *reading*.

We included more than 80 **activities**, because your brain is tuned to learn and remember more when you **do** things than when you *read* about things. And we made the exercises challenging-yet-do-able, because that's what most people prefer.

We used **multiple learning styles**, because *you* might prefer step-by-step procedures, while someone else wants to understand the big picture first, and someone else just wants to see an example. But regardless of your own learning preference, *everyone* benefits from seeing the same content represented in multiple ways.

We include content for **both sides of your brain**, because the more of your brain you engage, the more likely you are to learn and remember, and the longer you can stay focused. Since working one side of the brain often means giving the other side a chance to rest, you can be more productive at learning for a longer period of time.

And we included **stories** and exercises that present **more than one point of view**, because your brain is tuned to learn more deeply when it's forced to make evaluations and judgments.

We included **challenges**, with exercises, and by asking **questions** that don't always have a straight answer, because your brain is tuned to learn and remember when it has to *work* at something. Think about it—you can't get your *body* in shape just by *watching* people at the gym. But we did our best to make sure that when you're working hard, it's on the *right* things. That **you're not spending one extra dendrite** processing a hard-to-understand example, or parsing difficult, jargon-laden, or overly terse text.

We used **people**. In stories, examples, pictures, etc., because, well, because *you're* a person. And your brain pays more attention to *people* than it does to *things*.

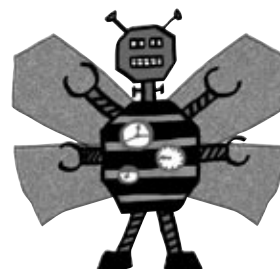
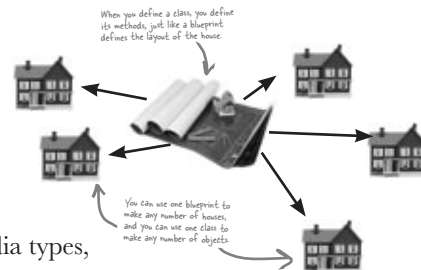

BULLET POINTS

Fireside Chats





Cut this out and stick it on your refrigerator.

Here's what YOU can do to bend your brain into submission

So, we did our part. The rest is up to you. These tips are a starting point; listen to your brain and figure out what works for you and what doesn't. Try new things.

-
- ① **Slow down.** The more you understand, the less you have to memorize.
Don't just *read*. Stop and think. When the book asks you a question, don't just skip to the answer. Imagine that someone really *is* asking the question. The more deeply you force your brain to think, the better chance you have of learning and remembering.
 - ② **Do the exercises.** Write your own notes. We put them in, but if we did them for you, that would be like having someone else do your workouts for you. And don't just *look* at the exercises. **Use a pencil.** There's plenty of evidence that physical activity *while* learning can increase the learning.
 - ③ **Read the "There are No Dumb Questions"** That means all of them. They're not optional sidebars—**they're part of the core content!** Don't skip them.
 - ④ **Make this the last thing you read before bed.** Or at least the last challenging thing. Part of the learning (especially the transfer to long-term memory) happens *after* you put the book down. Your brain needs time on its own, to do more processing. If you put in something new during that processing time, some of what you just learned will be lost.
 - ⑤ **Drink water.** Lots of it. Your brain works best in a nice bath of fluid. Dehydration (which can happen before you ever feel thirsty) decreases cognitive function.
 - ⑥ **Talk about it.** Out loud. Speaking activates a different part of the brain. If you're trying to understand something, or increase your chance of remembering it later, say it out loud. Better still, try to explain it out loud to someone else. You'll learn more quickly, and you might uncover ideas you hadn't known were there when you were reading about it.
 - ⑦ **Listen to your brain.** Pay attention to whether your brain is getting overloaded. If you find yourself starting to skim the surface or forget what you just read, it's time for a break. Once you go past a certain point, you won't learn faster by trying to shove more in, and you might even hurt the process.
 - ⑧ **Feel something.** Your brain needs to know that this *matters*. Get involved with the stories. Make up your own captions for the photos. Groaning over a bad joke is *still* better than feeling nothing at all.
 - ⑨ **Write a lot of software!** There's only one way to learn to program: **writing a lot of code.** And that's what you're going to do throughout this book. Coding is a skill, and the only way to get good at it is to practice. We're going to give you a lot of practice: every chapter has exercises that pose a problem for you to solve. Don't just skip over them—a lot of the learning happens when you solve the exercises. We included a solution to each exercise—don't be afraid to **peek at the solution** if you get stuck! (It's easy to get snagged on something small.) But try to solve the problem before you look at the solution. And definitely get it working before you move on to the next part of the book.

What you need for this book:

We wrote this book using Visual C# 2008 Express Edition, which uses C# 3.0 and .NET Framework 3.5. All of the screenshots that you see throughout the book were taken from that edition, so we recommend that you use it. If you're using Visual Studio 2008 Standard, Professional, or Team System editions, you'll see some small differences, which we've pointed out wherever possible. You can download the Express Edition for free from Microsoft's website—it installs cleanly alongside other editions, as well as previous versions of Visual Studio.

SETTING UP VISUAL STUDIO 2008 EXPRESS EDITION

- It's easy enough to download and install Visual C# 2008 Express Edition. Here's the link to the Visual Studio 2008 Express Edition download page:

<http://www.microsoft.com/express/download/>

Make sure that you check all of the options when you install it.



If you absolutely must use an older version of Visual Studio, C# or the .NET Framework, then please keep in mind that you'll come across topics in this book that won't be compatible with your version. The C# team at Microsoft has added some pretty cool features to the language. We'll give you warnings when we talk about any of these topics. But definitely keep in mind that if you're not using the latest version, there will be some code in this book that won't work.

- Download the installation package for Visual C# 2008 Express Edition. Make sure you do a complete installation. That should install everything that you need: the IDE (which you'll learn about), SQL Server Express Edition, and .NET Framework 3.5.
- Once you've got it installed, you'll have a new Start menu option: *Microsoft Visual C# 2008 Express Edition*. Click on it to bring up the IDE, and you're all set.

Read me

This is a learning experience, not a reference book. We deliberately stripped out everything that might get in the way of learning whatever it is we're working on at that point in the book. And the first time through, you need to begin at the beginning, because the book makes assumptions about what you've already seen and learned.

The activities are NOT optional.

The exercises and activities are not add-ons; they're part of the core content of the book. Some of them are to help with memory, some for understanding, and some to help you apply what you've learned. **Don't skip the written problems.** The pool puzzles are the only things you don't *have* to do, but they're good for giving your brain a chance to think about twisty little logic puzzles.

The redundancy is intentional and important.

One distinct difference in a Head First book is that we want you to *really* get it. And we want you to finish the book remembering what you've learned. Most reference books don't have retention and recall as a goal, but this book is about *learning*, so you'll see some of the same concepts come up more than once.

Do all the exercises!

The one big assumption that we made when we wrote this book is that you want to learn how to program in C#. So we know you want to get your hands dirty right away, and dig right into the code. We gave you a lot of opportunities to sharpen your skills by putting exercises in every chapter. We've labeled some of them "Do this!"—when you see that, it means that we'll walk you through all of the steps to solve a particular problem. But when you see the Exercise logo with the running shoes, then we've left a big portion of the problem up to you to solve, and we gave you the solution that we came up with. Don't be afraid to peek at the solution—**it's not cheating!** But you'll learn the most if you try to solve the problem first.

We've also placed all the exercise solutions' source code on the web so you can download it. You'll find it at <http://www.headfirstlabs.com/books/hfcsharp/>

The "Brain Power" exercises don't have answers.

For some of them, there is no right answer, and for others, part of the learning experience of the Brain Power activities is for you to decide if and when your answers are right. In some of the Brain Power exercises you will find hints to point you in the right direction.

We use a lot of diagrams to make tough concepts easier to understand.

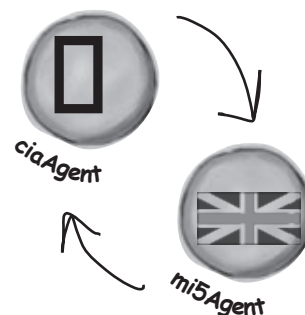

You should do ALL of the "Sharpen your pencil" activities



Activities marked with the Exercise (running shoe) logo are really important! Don't skip them if you're serious about learning C#.



If you see the Pool Puzzle logo, the activity is optional, and if you don't like twisty logic, you won't like these either.



The technical review team

Lisa Kellner



Joe Albahari



Jay Hilyard



Daniel Kinnaer



Not pictured (but just as awesome): Wayne Bradney, Dave Murdoch, and Bridgette Julie Landers

Aayam Singh



Theodore Casser



Andy Parker



Peter Ritchie



Bill Mietelski



Technical Reviewers:

When we wrote this book, it had a bunch of mistakes, issues, problems, typos, and terrible arithmetic errors. Okay, it wasn't quite that bad. But we're still really grateful for the work that our technical reviewers did for the book. We would have gone to press with errors (including one or two big ones) had it not been for the most kick-ass review team EVER...

First of all, we really want to thank **Joe Albahari** for the enormous amount of technical guidance. He really set us straight on a few really important things, and if it weren't for him you'd be learning incorrect stuff. We also want to thank **Lisa Kellner**—this is our third book that she's reviewed for us, and she made a huge difference in the readability of the final product. Thanks, Lisa! And special thanks to **Jay Hilyard** and **Daniel Kinnaer** for catching and fixing a whole lot of our mistakes, and **Aayam Singh** for actually going through and doing every one of these exercises **before** we fixed them and corrected their problems. Aayam, you're really dedicated. Thanks!

And special thanks to our favorite readers, David Briggs and Jaime Moreno, for going above and beyond the call of duty by finding and reporting many errors that we didn't catch in the first printing, and to Jon Skeet for going through the whole book carefully and helping us fix a bunch of errors.

Krishna Pala



Giuseppe Turitto



Acknowledgments

Our editor:

We want to thank our editor, **Brett McLaughlin**, for editing this book. He helped with a lot of the narrative, and the comic idea in Chapter 14 was completely his, and we think it turned out really well. Thanks, Brett!

Brett McLaughlin

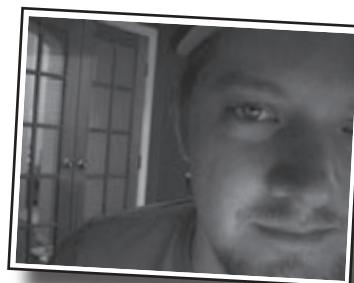

The O'Reilly team:



Lou Barr

Lou Barr is an amazing graphic designer who went above and beyond on this one, putting in unbelievable hours and coming up with some pretty amazing visuals. If you see anything in this book that looks fantastic, you can thank her (and her mad InDesign skillz) for it. She did all of the monster and alien graphics for the labs, and the entire comic book. Thanks so much, Lou! You are our hero, and you're awesome to work with.



Sanders Kleinfeld

There are so many people at O'Reilly we want to thank that we hope we don't forget anyone. First of all, the Head First team rocks—**Laurie Petrycki**, **Catherine Nolan**, **Sanders Kleinfeld** (the most super production editor ever!), **Caitrin McCullough**, **Keith McNamara**, and **Brittany Smith**. Special thanks to **Colleen Gorman** for her sharp proofread, **Ron Bilodeau** for volunteering his time and preflighting expertise, and **Adam Witwer** for offering one last sanity check—all of whom helped get this book from production to press in record time. And as always, we love **Mary Treseler**, and can't wait to work with her again! And a big shout out to our other friends and editors, **Andy Oram**, **Isabel Kunkle**, and **Mike Hendrickson**. And if you're reading this book right now, then you can thank the greatest publicity team in the industry: **Marsee Henon**, **Sara Peyton**, **Mary Rotman**, **Jessica Boyd**, **Kathryn Barrett**, and the rest of the folks at Sebastopol.

Safari® Books Online



When you see a Safari® icon on the cover of your favorite technology book that means the book is available online through the O'Reilly Network Safari Bookshelf.

Safari offers a solution that's better than e-books. It's a virtual library that lets you easily search thousands of top tech books, cut and paste code samples, download chapters, and find quick answers when you need the most accurate, current information. Try it for free at <http://safari.oreilly.com>.

1 get productive with c#

Visual Applications, in 10 minutes or less

Don't worry, Mother. With Visual Studio and C#, you'll be able to program so fast that you'll never burn the pot roast again.



Want to build great programs really fast?

With C#, you've got a **powerful programming language** and a **valuable tool** at your fingertips. With the **Visual Studio IDE**, you'll never have to spend hours writing obscure code to get a button working again. Even better, you'll be able to **focus on getting your work done**, rather than remembering which method parameter was for the *name* for a button, and which one was for its *label*. Sound appealing? Turn the page, and let's get programming.

C# makes it easy

Why you should learn C#

C# and the Visual Studio IDE make it easy for you to get to the business of writing code, and writing it fast. When you're working with C#, the IDE is your best friend and constant companion.

↖ The IDE—or Visual Studio Integrated Development Environment—is an important part of working in C#. It's a program that helps you edit your code, manage your files, and publish your projects.

Here's what the IDE automates for you...

Every time you want to get started writing a program, or just putting a button on a form, your program needs a whole bunch of repetitive code.

```
using System;
using System.Collections.Generic;
using System.Windows.Forms;
namespace A_New_Program
{
    static class Program
    {
        /// <summary>
        /// The main entry point for the application.
        /// </summary>
        [STAThread]
        static void Main()
        {
            Application.EnableVisualStyles();
            Application.SetCompatibleTextRenderingDefault(false);
            Application.Run(new Form1());
        }
    }
}
```

```
private void InitializeComponent()
{
    this.button1 = new System.Windows.Forms.Button();
    this.SuspendLayout();
    //
    // button1
    //
    this.button1.Location = new System.Drawing.Point(105, 56);
    this.button1.Name = "button1";
    this.button1.Size = new System.Drawing.Size(75, 23);
    this.button1.TabIndex = 0;
    this.button1.Text = "button1";
    this.button1.UseVisualStyleBackColor = true;
    this.button1.Click += new System.EventHandler(this.button1_Click);
    //
    // Form1
    //
    this.AutoScaleMode = System.Windows.Forms.AutoScaleMode.None;
    this.AutoScaleDimensions = new System.Drawing.SizeF(8F, 16F);
    this.ClientSize = new System.Drawing.Size(292, 267);
    this.Controls.Add(this.button1);
    this.Name = "Form1";
    this.Text = "Form1";
    this.ResumeLayout(false);
}
```

↖ It takes all this code just to draw a button on a form. Adding a few more visual elements to the form could take ten times as much code.

What you get with Visual Studio and C#...

With a language like C#, tuned for Windows programming, and the Visual Studio IDE, you can focus on what your program is supposed to **do** immediately:

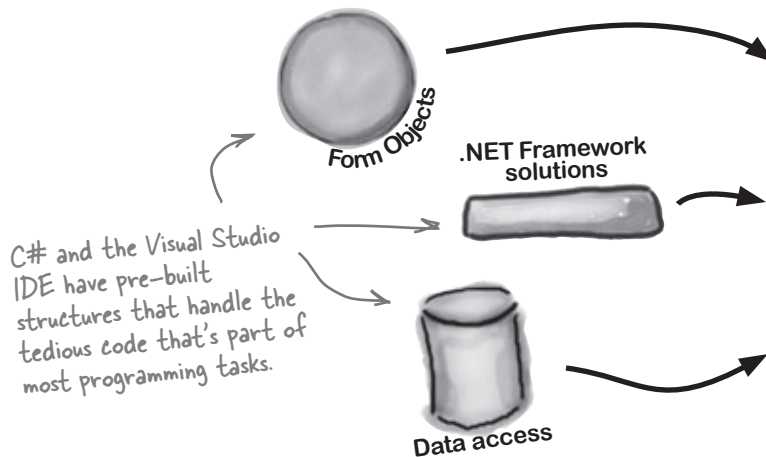

↖ The result is a better looking application that takes less time to write.

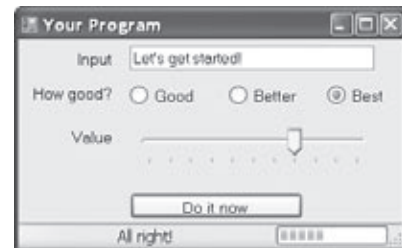

C# and the Visual Studio IDE make lots of things easy

When you use C# and Visual Studio, you get all of these great features, without having to do any extra work. Together, they let you:

- 1 **Build an application, FAST.** Creating programs in C# is a snap. The language is powerful and easy to learn, and the Visual Studio IDE does a lot of work for you automatically. You can leave mundane coding tasks to the IDE and focus on what your code should accomplish.
- 2 **Design a great looking user interface.** The Form Designer in the Visual Studio IDE is one of the easiest design tools to use out there. It does so much for you that you'll find that making stunning user interfaces is one of the most satisfying parts of developing a C# application. You can build full-featured professional programs without having to spend hours writing a graphical user interface entirely from scratch.
- 3 **Create and interact with databases.** The IDE includes a simple interface for building databases, and integrates seamlessly with SQL Server Express, as well as several other popular database systems.
- 4 **Focus on solving your REAL problems.** The IDE does a lot for you, but *you* are still in control of what you build with C#. The IDE just lets you focus on your program, your work (or fun!), and your customers. But the IDE handles all the grunt work, such as:
 - ★ Keeping track of all of your projects
 - ★ Making it easy to edit your project's code
 - ★ Keeping track of your project's graphics, audio, icons, and other resources
 - ★ Managing and interacting with databases

All this means you'll have all the time you would've spent doing this routine programming to put into **building killer programs**.

↖ You're going to see exactly what we mean next.

Help the CEO go paperless

The Objectville Paper Company just hired a new CEO. He loves hiking, coffee, and nature... and he's decided that to help save forests. He wants to become a paperless executive, starting with his contacts. He's heading to Aspen to go ski for the weekend, and expects a new address book program by the time he gets back. Otherwise... well... it won't be just the old CEO who's looking for a job.

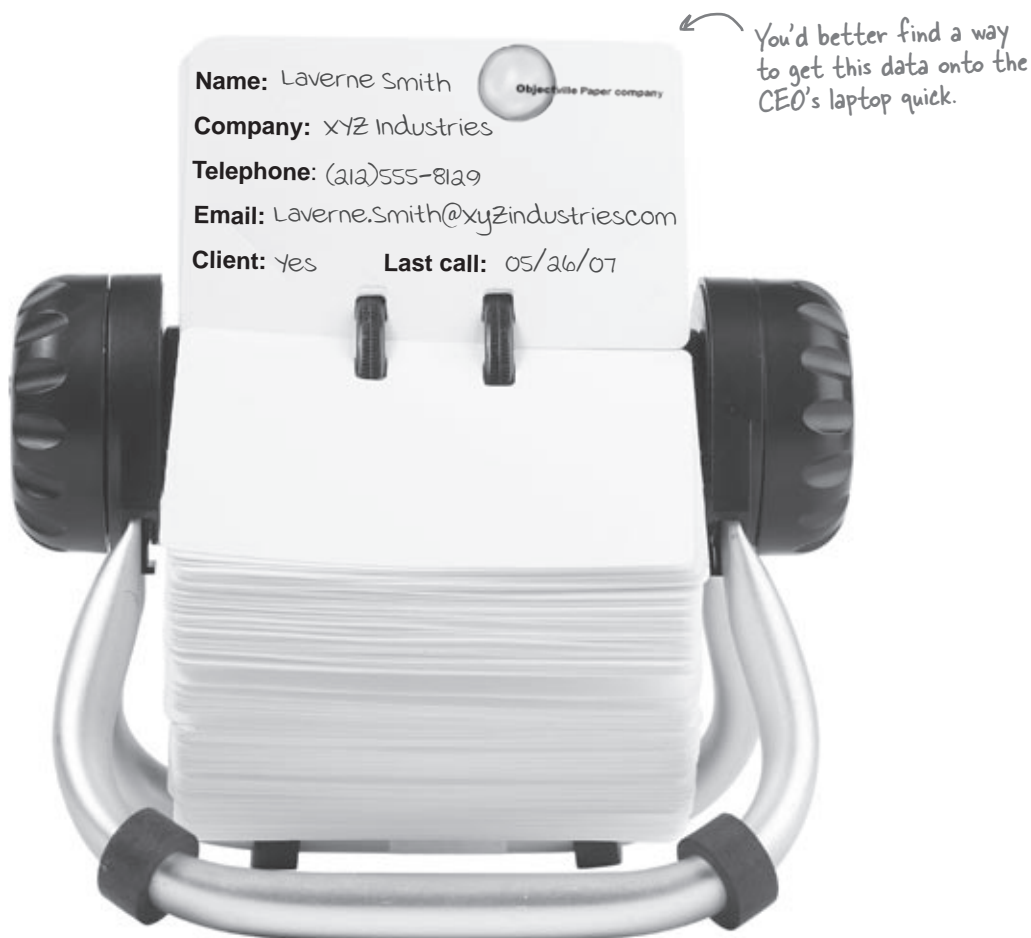

Get to know your users' needs before you start building your program

Before we can start writing the address book application—or *any* application—we need to take a minute and think about **who's going to be using it**, and **what they need** from the application.

- ① The CEO needs to be able to run his address book program at work and on his laptop too. He'll need an installer to make sure that all of the right files get onto each machine.

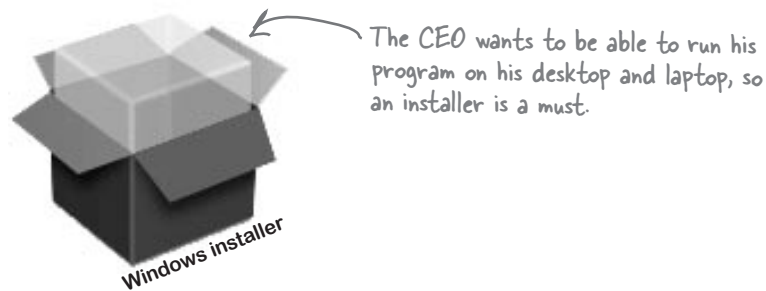

- ② The Objectville Paper company sales team wants to access his address book, too. They can use his data to build mailing lists and get client leads for more paper sales.

The CEO figures a database would be the best way that everyone in the company to see his data, and then he can just keep up with one copy of all his contacts.

We already know that Visual C# makes working with databases easy. Having contacts in a database lets the CEO and the sales team all access the information, even though there's only one copy of the data.



Here's what you're going to build

You're going to need an application with a graphical user interface, objects to talk to a database, the database itself, and an installer. It sounds like a lot of work, but you'll build all of this over the next few pages.

Here's the structure of the program we're going to create:

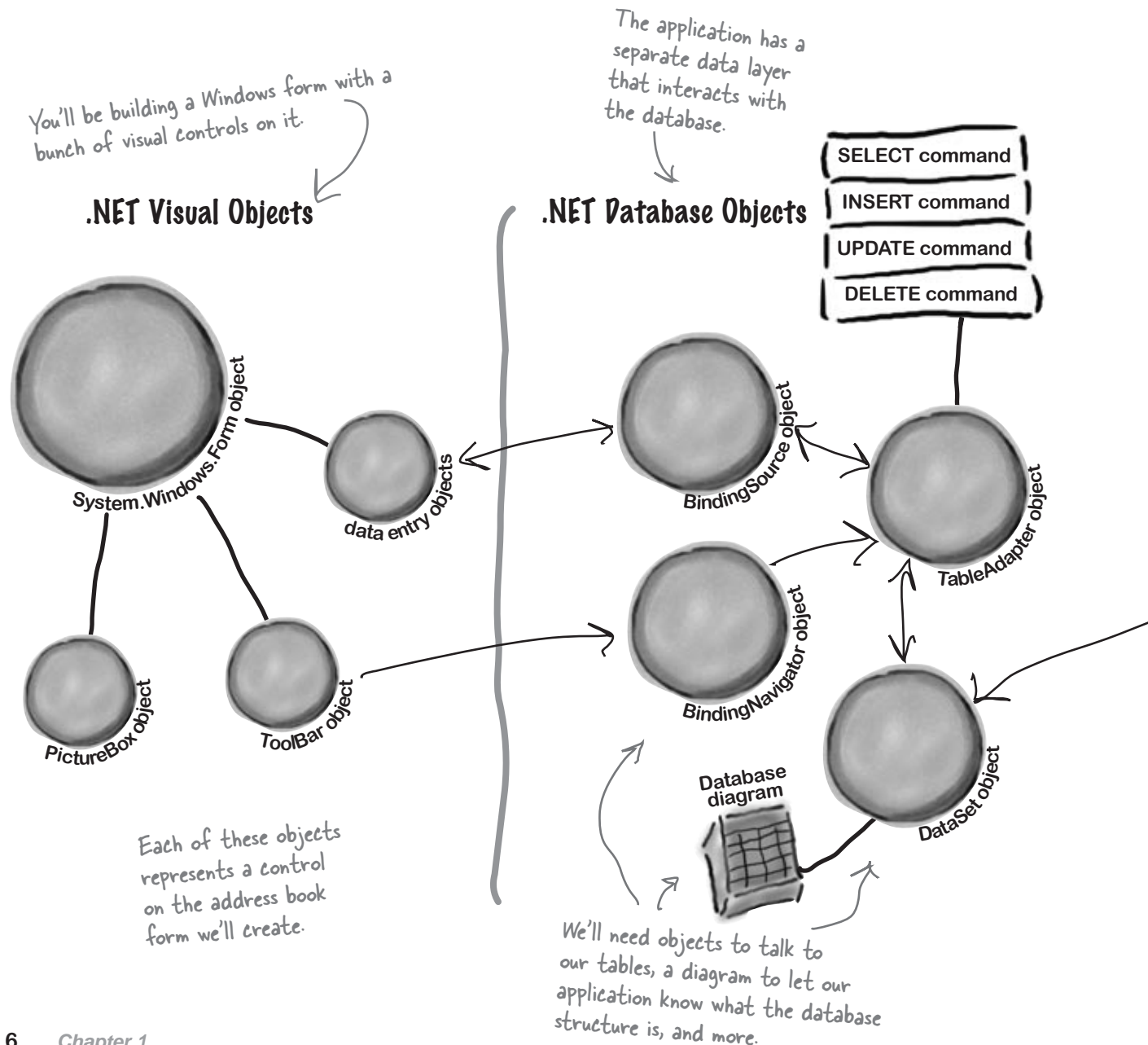

The data is all stored in a table in a SQL Server Express database.

Data Storage

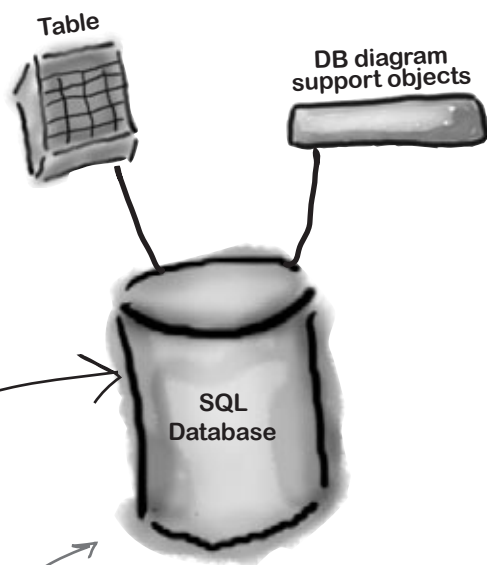

Here's the database itself, which Visual Studio will help us create and maintain.

Once the program's built, it'll be packaged up into a Windows installer.

Deployment Package

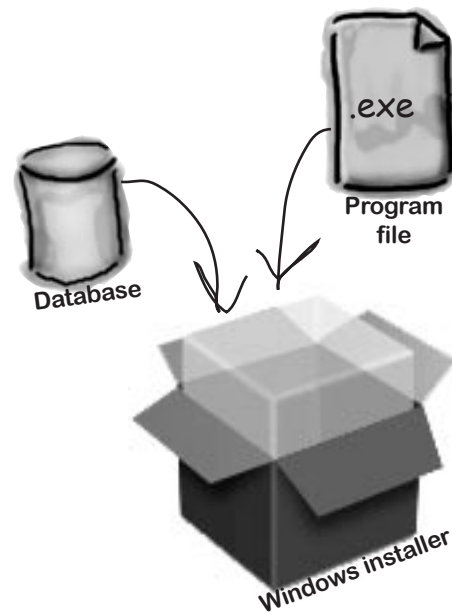

The sales department will just need to point and click to install and then use his program.

What you do in Visual Studio...

Go ahead and start up Visual Studio, if you haven't already. Skip over the start page and select New Project from the **File** menu. Name your project "Contacts" and click OK.

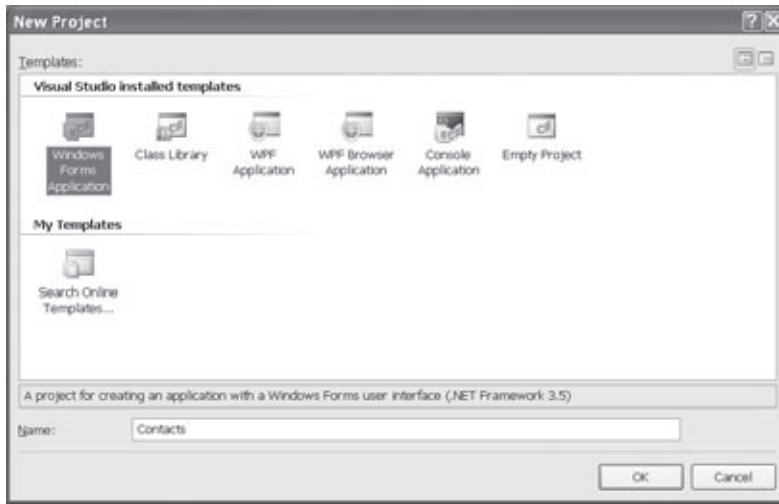

Things may look a bit different in your IDE.

This is what the "New Project" window looks like in Visual Studio 2008 Express Edition. If you're using the Professional or Team Foundation edition, it might be a bit different. But don't worry, everything still works exactly the same.

What Visual Studio does for you...

As soon as you save the project, the IDE creates a Form1.cs, Form1.Designer.cs, and Program.cs file when you create a new project. It adds these to the Solution Explorer window, and by default, puts those files in My Documents\Visual Studio 2008\Projects\Contacts\.

Make sure that you save your project as soon as you create it by selecting "Save All" from the File menu—that'll save all of the project files out to the folder. If you select "Save", it just saves the one you're working on.

This file contains the C# code that defines the behavior of the form.



Form1.cs

This has the code that starts up the program and displays the form.



Program.cs

The code that defines the form and its objects lives here.



Form1.Designer.cs

Visual Studio creates all three of these files automatically.

Sharpen your pencil

Below is what your screen probably looks like right now. You should be able to figure out what most of these windows and files are based on what you already know. In each of the blanks, try and fill in an annotation saying what that part of the IDE does. We've done one to get you started.

This toolbar has buttons that apply to what you're currently doing in the IDE.

If your IDE doesn't look exactly like this picture, you can select "Reset Window Layout" from the Window menu.

We've blown up this window below so you have more room.

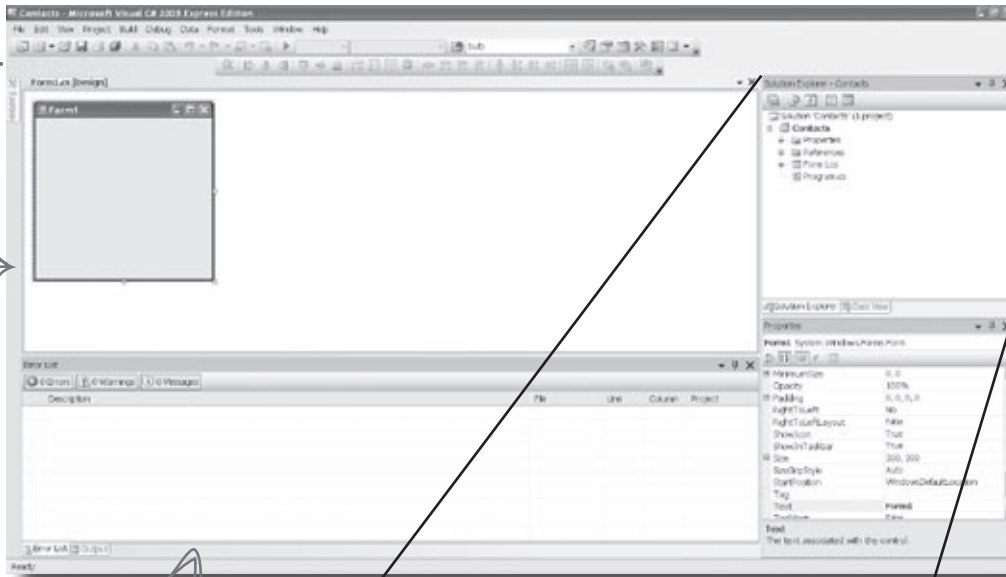

You can also bring up these windows by selecting Solution Explorer, Properties, or Error List from the View menu.

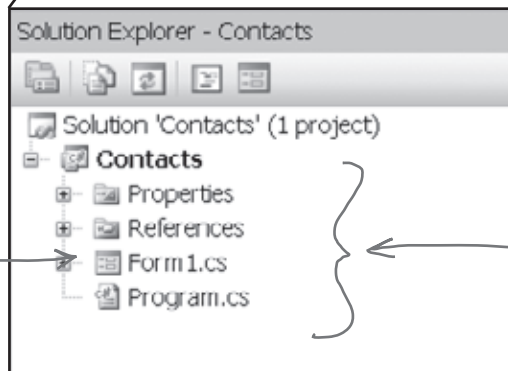

Sharpen your pencil Solution

We've filled in the annotations about the different sections of the Visual Studio C# IDE. You may have some different things written down, but you should have been able to figure out the basics of what each window and section of the IDE is used for.

This toolbar has buttons that apply to what you're currently doing in the IDE.

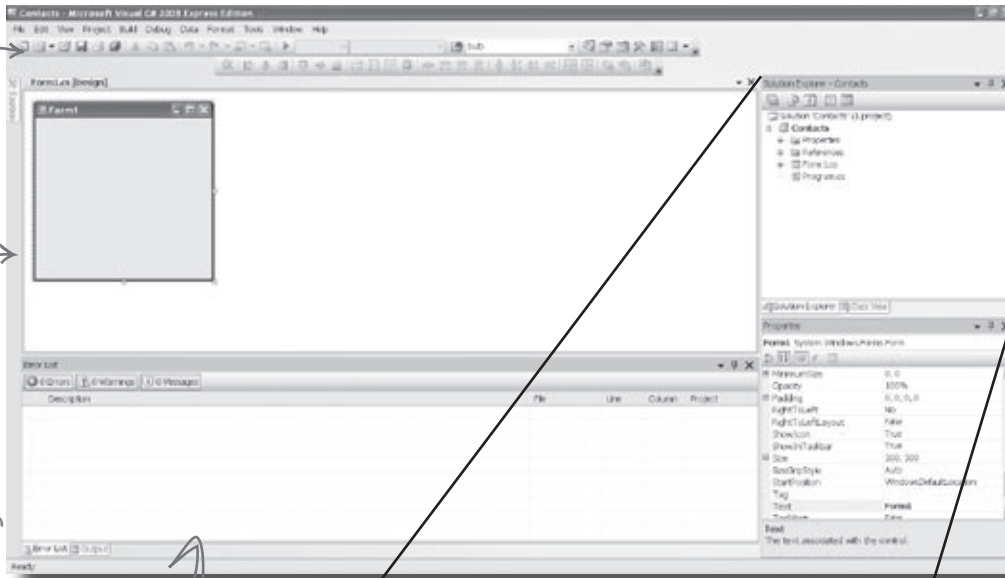

This is the toolbox. It has a bunch of visual controls that you can drag onto your form.

This bottom pane is for debugging. It shows you when there are errors in your code.

The Form1.cs and Program.cs files that the IDE created for you when you added the new project appear in the Solution Explorer.

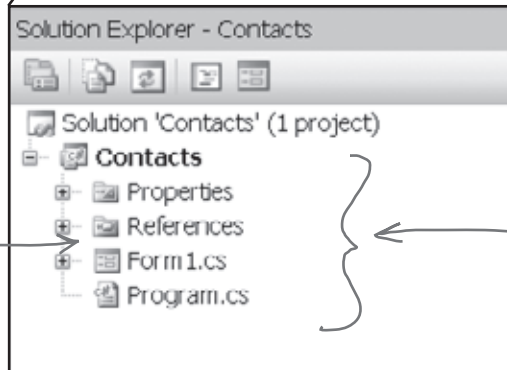

You can switch between files using the Solution Explorer in the IDE.

This window shows all of the properties of the controls on your form.

there are no Dumb Questions

Q: So if the IDE writes all this code for me, is learning C# just a matter of learning how to use the IDE?

A: No. The IDE is great at automatically generating some code for you, but it can only do so much. There are some things it's really good at, like setting up good starting points for you, and automatically changing properties of controls on your forms. But the hard part of programming—figuring what your program needs to do and making it do it—is something that no IDE can do for you. Even though the Visual Studio IDE is one of the most advanced development environments out there, it can only go so far. It's *you*—not the IDE—who writes the code that actually does the work.

Q: I created a new project in Visual Studio, but when I went into the “Projects” folder under My Documents, I didn't see it there. What gives?

A: First of all, you must be using Visual Studio 2008—in 2005, this doesn't happen. When you first create a new project in Visual Studio 2008, the IDE creates the project in your `Local Settings\Application Data\Temporary Projects` folder. When you save the project for the first time, it will prompt you for a new filename, and save it in the `My Documents\Visual Studio 2008\Projects` folder. If you try to open a new project or close the temporary one, you'll be prompted to either save or discard the temporary project.

Q: What if the IDE creates code I don't want in my project?

A: You can change it. The IDE is set up to create code based on the way the element you dragged or added is most commonly

used. But sometimes that's not exactly what you wanted. Everything the IDE does for you—every line of code it creates, every file it adds—can be changed, either manually by editing the files directly or through an easy-to-use interface in the IDE.

Q: Is it OK that I downloaded and installed Visual Studio Express? Or do I need to use one of the versions of Visual Studio that isn't free in order to do everything in this book?

A: There's nothing in this book that you can't do with the free version of Visual Studio (which you can download from Microsoft's website). The main differences between Express and the other editions (Professional and Team Foundation) aren't going to get in the way of writing C# and creating fully functional, complete applications.

Q: Can I change the names of the files the IDE generates for me?

A: Absolutely. When you create a new project, the IDE gives you a default form called `Form1` (which has files called `Form1.cs`, `Form1.Designer.cs` and `Form1.resx`). But you can use the Solution Explorer to change the names of the files to whatever you want. By default, the names of the files are the same as the name of the form. If you change the names of the files, you'll be able to see in the Properties window that form will still be called `Form1`. You can change the name of the form by changing the “(Name)” line in the Properties window. If you do, the filenames won't change.

C# doesn't care what names you choose for your files or your forms (or any other part of the program). But if you choose good names, it makes your programs easier to work with. For now, don't worry about names—we'll talk a lot more about how to choose good names for parts of your program later on.

Q: I'm looking at the IDE right now, but my screen doesn't look like yours! It's missing some of the windows, and others are in the wrong place. What gives?

A: If you click on the “Reset Window Layout” command under the “Window” menu, the IDE will restore the default window layout for you. Then your screen will look just like the ones in this chapter.

Visual Studio will generate code you can use as a starting point for your applications. Making sure the application does what it's supposed to do is still up to you.

Develop the user interface

Adding controls and polishing the user interface is as easy as dragging and dropping with the Visual Studio IDE. Let's add a logo to the form:

1 Use the PictureBox control to add a picture.

Click on the PictureBox control in the Toolbox, and drag it onto your form. In the background, the IDE added code to `Form1.Designer.cs` for a new picture control.

If you don't see the toolbox, try hovering over the word "Toolbox" that shows up in the upper left-hand corner of the IDE. If it's not there, select "Toolbox" from the View menu to make it appear.

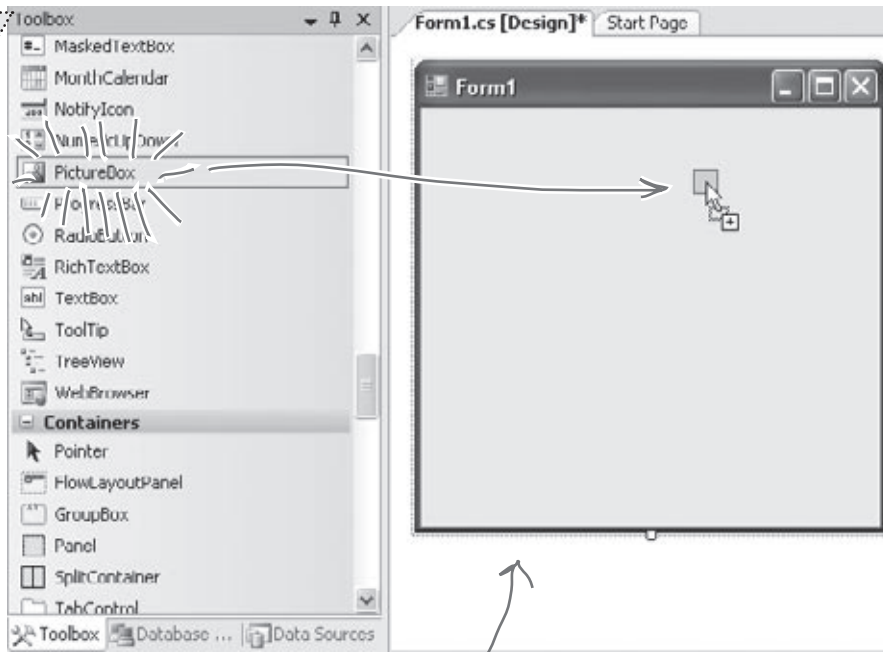

Every time you make a change to a control's properties on the form, the code in `Form1.Designer.cs` is getting changed by the IDE.



Form1.Designer.cs



It's OK if you're not a pro at user interface design.

We'll talk a lot more about designing good user interfaces later on. For now, just get the logo and other controls on your form, and worry about **behavior**. We'll add some style later.

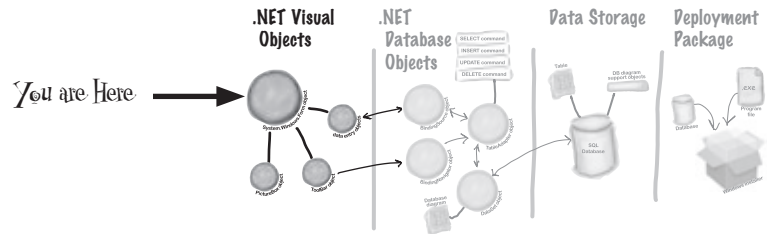

2 Set the PictureBox to Zoom mode.

Every control on your form has properties that you can set. Click the little black arrow for a control to access these properties. Change the PictureBox's Size property to "Zoom" to see how this works:

You can also use the "Properties" window in the IDE to set the Size property. The little black arrow is just there to make it easy to access the most common properties of any control.

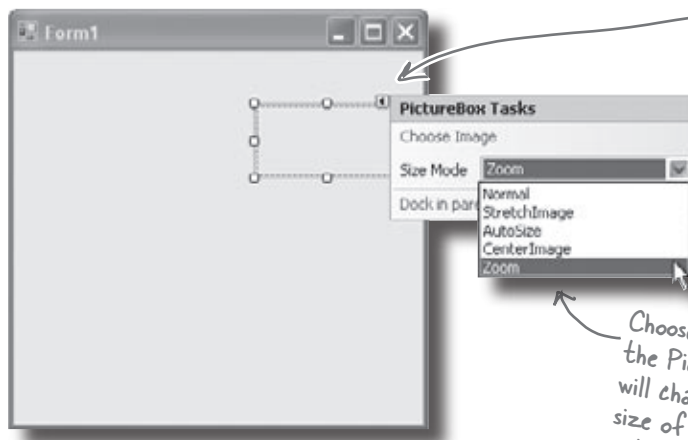

Click on this little black arrow to access a control's properties.

Choose "Zoom" so that the PictureBox frame will change to match the size of the picture you put in it.

Then click "Choose Image" to bring up the Select Resource dialog box so you can import a local resource.

3 Download the Objectville Paper Company logo.

Download the Objectville Paper Co. logo from Head First Labs (<http://www.headfirstlabs.com/books/hfcsharp>) and save it to your hard drive. Then click the PictureBox properties arrow, and select Choose Image. You'll see a Select Resources window pop up. Click the "Local Resource" radio button to enable the "Import..." button at the top of the form. Click that button, find your logo, and you're all set.



Here's the OPC logo, and the PictureBox zooms to get the size just right.

Visual Studio, behind the scenes

Every time you do something in the Visual Studio IDE, the IDE is *writing code for you*. When you created the logo and told Visual Studio to use the image you downloaded, Visual Studio created a resource and associated it with your application. A **resource** is any graphics file, audio file, icon, or other kind of data file that gets bundled with your application. The graphic file gets integrated into the program, so that when it's installed on another computer, the graphic is installed along with it and the PictureBox can use it.

When you dragged the PictureBox control onto your form, the IDE automatically created a resource file called Form1.resx to store that resource and keep it in the project. Double-click on this file, and you'll be able to see the newly imported image.

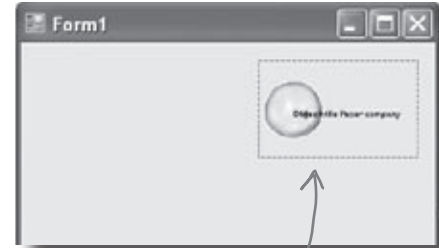

This image is now a resource of the Contact List application.

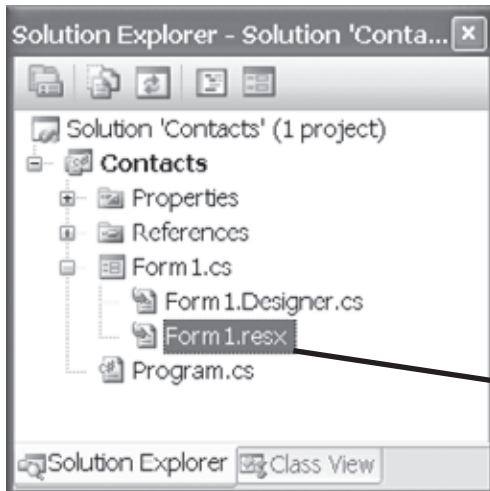

Go to the Solution Explorer and click on the plus icon next to Form1.cs to expand it (if it's not already expanded). This will display two files: Form1.Designer.cs and Form1.resx. Double-click on Form1.resx, click on the arrow next to "Strings", and select "Images" from the drop-down list (or hit Ctrl-2) to see the logo that you imported. That file is what links it to the PictureBox, and the IDE added code to do the linking.

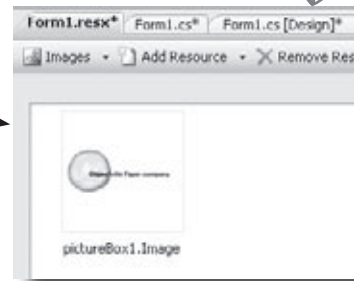

If you chose the other "Import..." button from the Select Resource dialog on the last page, then your image will show up in the Resources folder in the Solution Explorer instead. Don't worry—just go back to Select Resources, choose "Local Resource," and reimport the image into the resources, and it'll show up here.

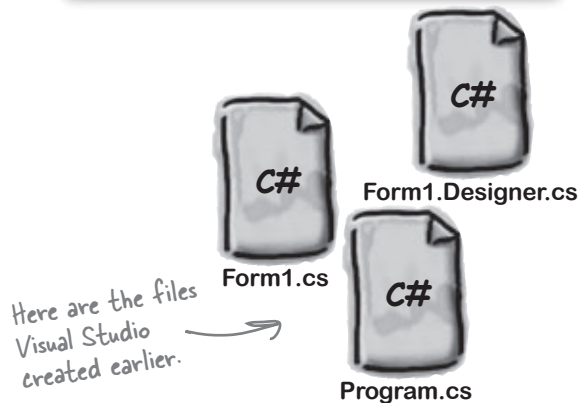

When you imported the image, the IDE created this file for you. It contains all of the resources (graphics, video, audio and other stored data) associated with Form1.

Add to the auto-generated code

The IDE creates lots of code for you, but you'll still want to get into this code and add to it. Let's set the logo up to show an About message when the users run the program and click on the logo.

When you're editing a form in the IDE, double-clicking on any of the toolbox controls causes the IDE to automatically add code to your project. Make sure you've got the form showing in the IDE, and then double-click on the PictureBox control. The IDE will add code to your project that gets run any time a user clicks on the PictureBox. You should see some code pop up that looks like this:

```
public partial class Form1 : Form
{
```

```
    public Form1()
    {
```

```
        InitializeComponent();
    }
```

```
    private void pictureBox1_Click(object sender, EventArgs e)
    {
```

```
        MessageBox.Show("Contact List 1.0.\nWritten by: Your Name", "About");
    }
```

```
}
```

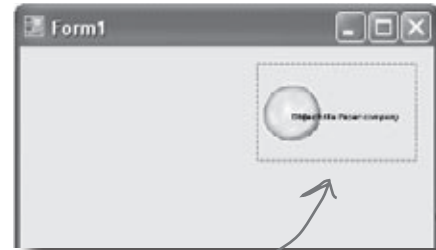

When you double-clicked on the PictureBox control, the IDE created this method. It will run every time a user clicks on the logo in the running application.

This method name gives you a good idea about when it runs: when someone clicks on this PictureBox control.

When you double-click on the PictureBox, it will open this code up with a cursor blinking right here. Ignore any windows the IDE pops up as you type; it's trying to help you, but we don't need that right now.

Type in this line of code. It causes a message box to popup with the text you provide. The box will be titled "About".

Once you've typed in the line of code, save it using the Save icon on the IDE toolbar or by selecting "Save" from the File menu. Get in the habit of doing "Save All" regularly!

there are no Dumb Questions

Q: What's a method?

A: A method is just a *named block of code*. We'll talk a lot more about methods in Chapter 2.

Q: What does that \n thing do?

A: That's a line break. It tells C# to put "Contact List 1.0." on one line, and then start a new line for "Written by:".

run the app (already!)

You can already run your application

Press the F5 key on your keyboard, or click the green arrow button (▶) on the toolbar to check out what you've done so far. (This is called "Debugging", which just means running your program using the IDE.) You can stop debugging by selecting "Stop Debugging" from the Debug menu or clicking this toolbar button: .

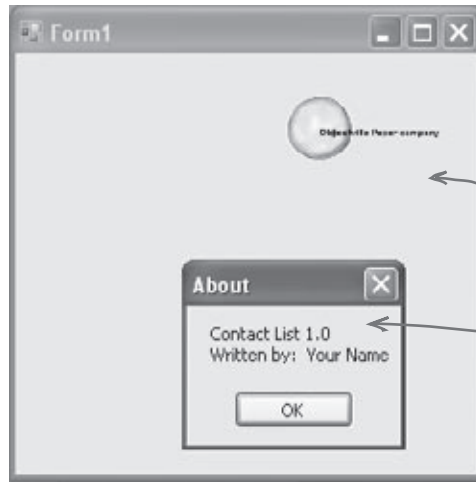

All three of these buttons work—and you didn't have to write any code to make them work.

Clicking on the OPC logo brings up the About box you just coded.

Where are my files?

When you run your program, Visual Studio copies all of your files to My Documents\Visual Studio 2008\Projects\Contacts\Contacts\bin\debug. You can even hop over to that directory and run your program by double-clicking on the .exe file the IDE creates.

C# turns your program into a file that you can run, called an **executable**. You'll find it in here, in the debug folder.



This isn't a mistake; there are two levels of folders. The inner folder has the actual C# code files.

there are no Dumb Questions

Q: In my IDE, the green arrow is marked as "Debug". Is that a problem?

A: No. Debugging, at least for our purposes right now, just means running your application inside the IDE. We'll talk a lot more about debugging later, but for now, you can simply think about it as a way to run your program.

Q: I don't see the Stop Debugging button on my toolbar. What gives?

A: The Stop Debugging button only shows up in a special toolbar that **only shows up** when your program is running. Try starting the application again, and see if it appears.

Here's what we've done so far

We've built a form and created a PictureBox object that pops up a message box when it's clicked on. Next, we need to add all the other fields from the card, like the contact's name and phone number.

Let's store that information in a database. Visual Studio can connect fields directly to that database for us, which means we don't have to mess with lots of database access code (which is good). But for that to work, we need to create our database so that the controls on the form can hook up to it. So we're going to jump from the .NET Visual Objects straight to the Data Storage section.

.NET Visual Objects

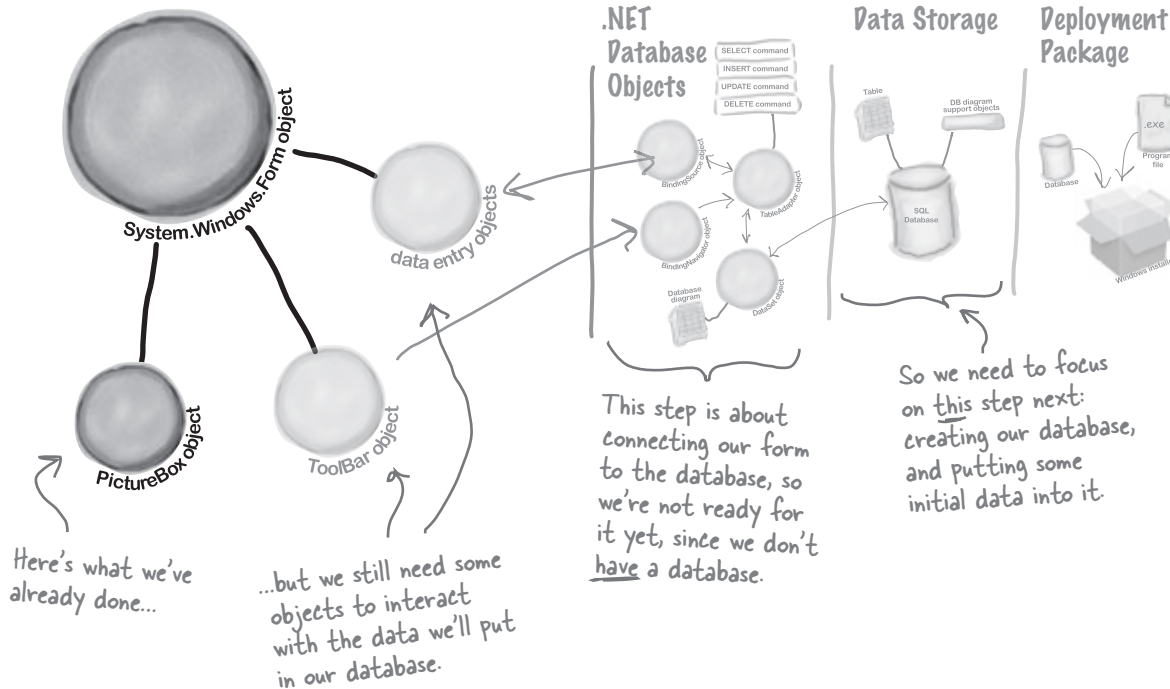

Visual Studio can generate code to connect your form to a database, but you need to have the database in place **BEFORE** generating that code.

We need a database to store our information

Before we add the rest of the fields to the form, we need to create a database to hook the form up to. The IDE can create lots of the code for connecting our form to our data, but we need to define the database itself first.

Make sure you've stopped debugging before you continue.

1 Add a new SQL database to your project.

In the Solution Explorer, **right-click the Contacts project**, select **Add**, and then choose **New Item**. Choose the **SQL Database** icon, and name it **ContactDB.mdf**.

This file is our new database.



ContactDB.mdf

Pick the right icon for the version you're using. Choose **SQL Database** if you're using Visual Studio Express 2005 and **Service-Based Database** if you're using 2008.

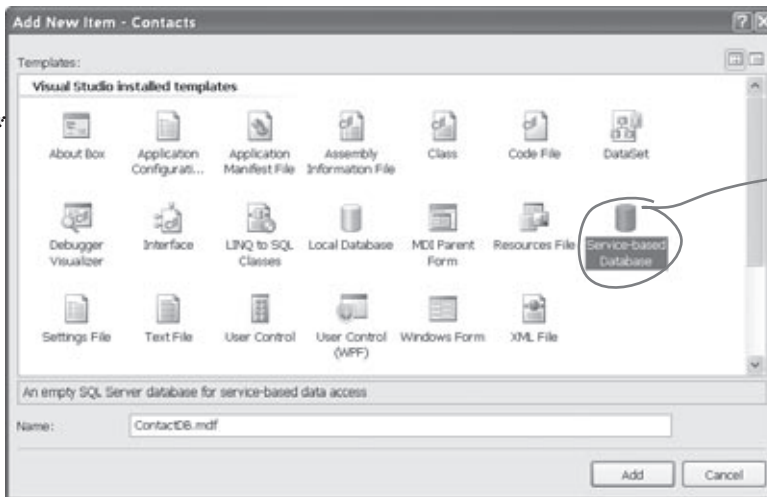

The SQL Database icon only works if you have SQL Server Express installed. Flip back to the README if you're not sure how to do this.

2 Click on the Add button in the Add New Item window.

3 Cancel the Data Source Configuration Wizard.

For now, we want to skip configuring a data source, so click the **Cancel** button. We'll come back to this once we've set up our database structure.

4 View your database in the Solution Explorer.

Go to the Solution Explorer, and you'll see that **ContactDB** has been added to the file list. Double click **ContactDB.mdf** in the Solution Explorer and look at the left side of your screen. The **Toolbox** has changed to a **Database Explorer**.



Watch it!

If you're not using the Express edition, you'll see "Server Explorer" instead of "Database Explorer".

The Visual Studio 2008 Professional and Team Foundation editions don't have a Database Explorer window. Instead, they have a Server Explorer window, which does everything the Database Explorer does, but also lets you explore data on your network.

The IDE created a database

When you told the IDE to add a new SQL database to your project, the IDE created a new database for you. A **SQL database** is a system that stores data for you in an organized, interrelated way. The IDE gives you all the tools you need to maintain your data and databases.

Data in a SQL database lives in tables. For now, you can think of a table like a spreadsheet. It organizes your information into columns and rows. The columns are the data categories, like a contact's name and phone number, and each row is the data for one contact card.

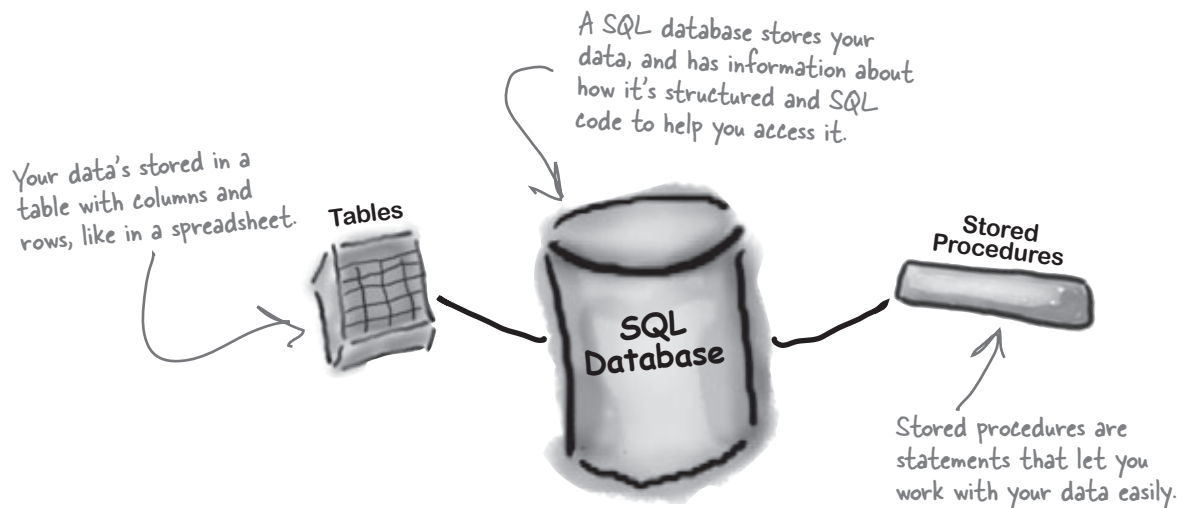
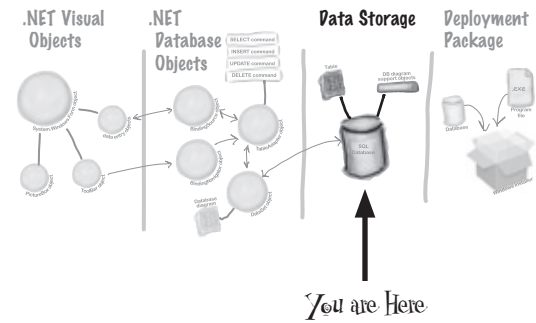

SQL is its own language

SQL stands for **Structured Query Language**. It's a programming language for accessing data in databases. It's got its own syntax, keywords, and structure. SQL code takes the form of **statements** and **queries**, which access and retrieve the data. A SQL database can hold **stored procedures**, which are a bunch of SQL statements and queries that are stored in the database and can be run at any time. The IDE generates SQL statements and stored procedures for you automatically to let your program access the data in the database.

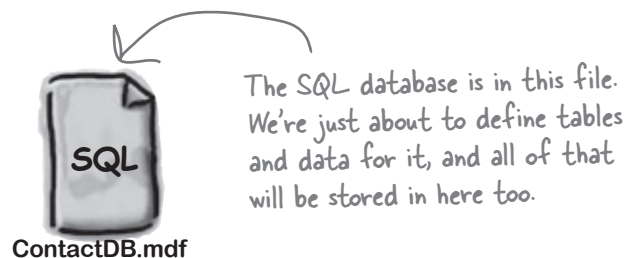

← [note from marketing: Can we get a plug for Head First SQL in here?]

Creating the table for the Contact List

We have a database, and now we need to store information in it. But our information actually has to go into a table, the data structure that databases use to hold individual bits of data. For our application, let's create a table called "People" to store all the contact information:

- 1 Add a table to the ContactDB database.**
 Right click on Tables in the Database Explorer, and select Add New Table. This will open up a window where you can define the columns in the table you just created.

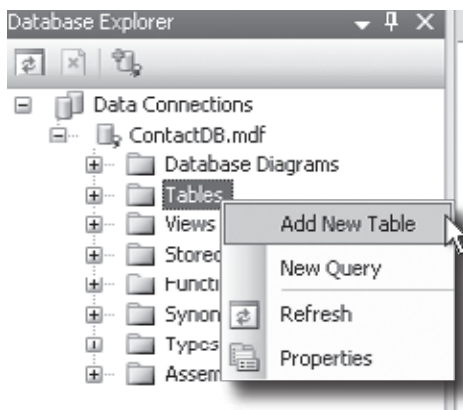

Now we need to add columns to our table. First, let's add a column called ContactID to our new People table, so that each Contact record has its own unique ID.

- 2 Add a ContactID column to the People table.**
 Type "ContactID" in the Column Name field, and select Int from the Data Type dropdown box. Be sure to uncheck the Allow Nulls checkbox.

Finally, let's make this the primary key of our table. Highlight the ContactID column you just created, and click the Primary Key button. This tells the database that each entry will have a unique primary key entry.



This is the Primary Key button. A primary key helps your database look up records quickly.

there are no Dumb Questions

Q: What's a column again?

A: A column is one field of a table. So in a People table, you might have a FirstName and LastName column. It will always have a data type, too, like String or Date or Bool.

Q: Why do we need this ContactID column?

A: It helps to have a unique ID for each record in most database tables. Since we're storing contact information for individual people, we decided to create a column for that, and call it ContactID.

Q: What's that Int from Data Type mean?

A: The data type tells the database what type of information to expect for a column. Int stands for integer, which is just a whole number. So the ContactID column will have whole numbers in it.

Q: This is a lot of stuff. Should I be getting all of this?

A: No, it's OK if you don't understand everything right now. Focus on the basic steps, and we'll spend a lot more time on databases in the later chapters of the book. And if you're dying to know more right away, you can always pick up *Head First SQL* to read along with this book.

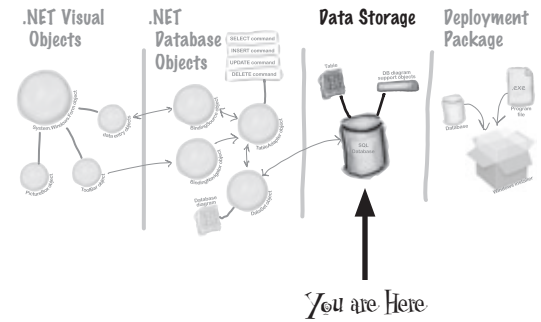

3 Tell the database to auto-generate IDs.

Since ContactID is a number for the database, and not our users, we can tell our database to handle creating and assigning IDs for us automatically. That way, we don't have to worry about writing any code to do this.

In the properties below your table, scroll down to Identity Specification, click the + button, and select Yes next to the (Is Identity) property.

This window is what you use to define your table and the data it will store.

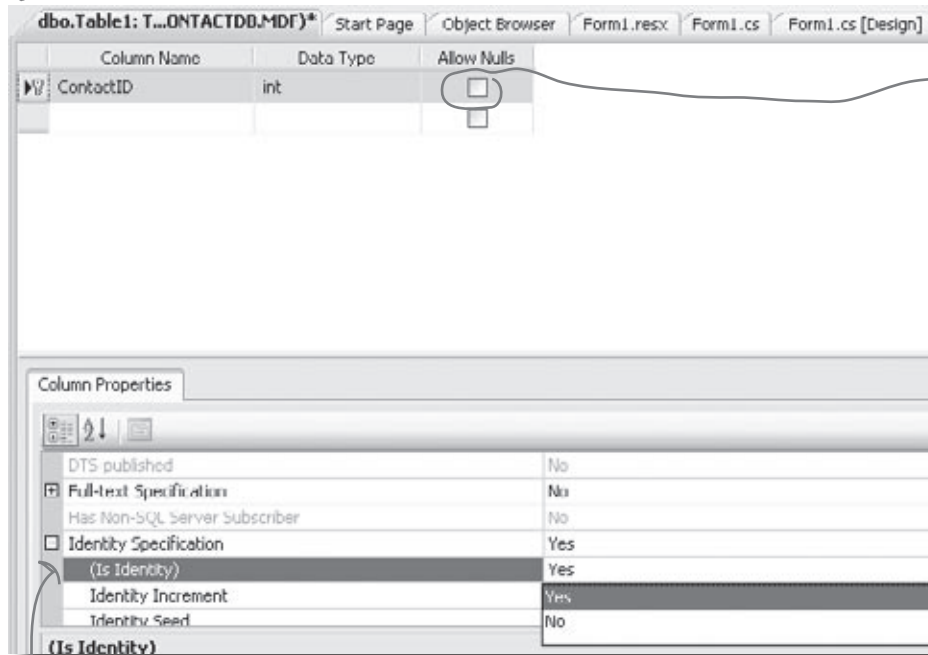

It's important that you leave this unchecked. Since the primary key is the main way your program will locate records, it always needs to have a value.

This will make it so that the ContactID field updates automatically whenever a new record is added.

You'll need to click on the right column and select Yes from the dropdown next to IsIdentity to designate ContactID as your record Identifier.

The blanks on contact card are columns in our People table

Now that you've created a primary key for the table, you need to define all of the fields you're going to track in the database. Each field on our written contact card should become a column in the People table.

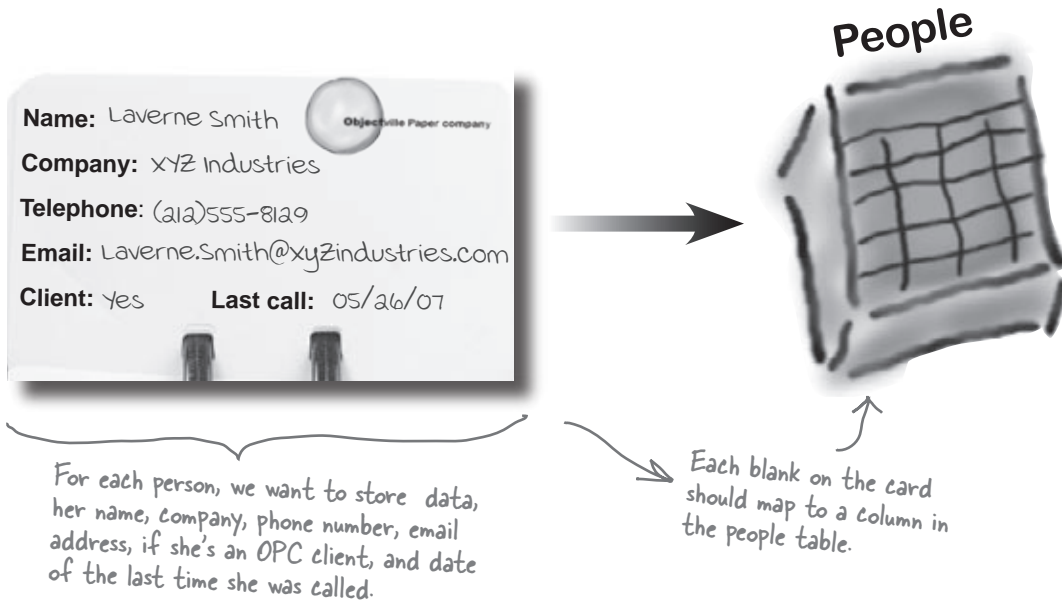

What kinds of problems could result from having multiple rows stored for the same person?

WHO DOES WHAT?

Now that you've created a People table and a primary key column, you need to add columns for all of the data fields. See if you can work out which data type goes with each of the columns in your table, and also match the data type to the right description.

Column Name	Data Type	Description
Last Call	int	This type stores a date and time
Name	bit	A Boolean true/false type
ContactID	nvarchar(50)	A string of letters, numbers and other characters with a maximum length of 50
Client?	datetime	A whole number

WHO DOES WHAT?

Now that you've created a People table and a primary key column, you need to add columns for all of the data fields. See if you can work out which data type goes with each of the columns in your table, and also match the data type to the right description.

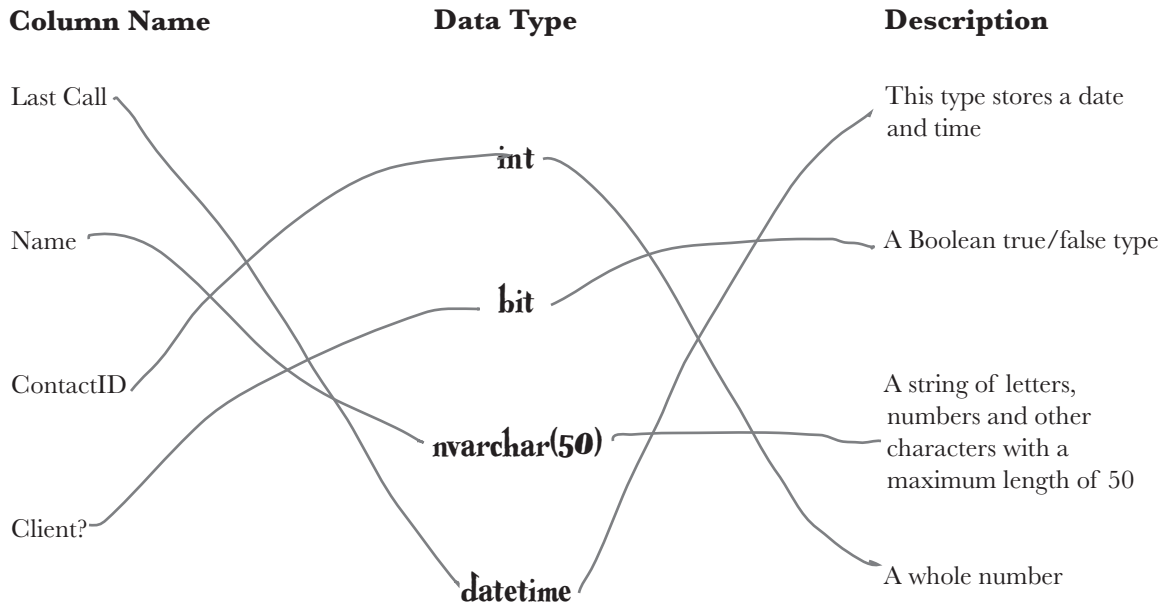

Finish building the table

Go back to where you entered the ContactID column and add the other five columns from the contact card. Here's what your database table should look like when you're done:

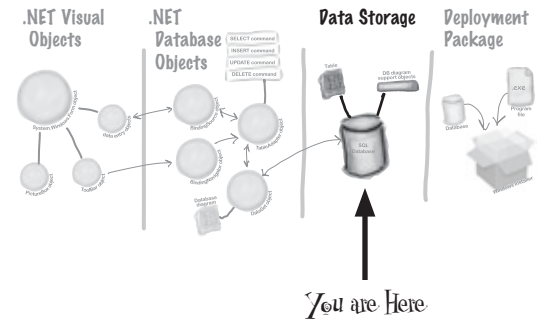

Column Name	Data Type	Allow Nulls
ContactID	int	<input type="checkbox"/>
Name	nvarchar(50)	<input checked="" type="checkbox"/>
Company	nvarchar(50)	<input checked="" type="checkbox"/>
Telephone	nvarchar(50)	<input checked="" type="checkbox"/>
Email	nvarchar(50)	<input checked="" type="checkbox"/>
Client	bit	<input checked="" type="checkbox"/>
LastCall	datetime	<input checked="" type="checkbox"/>
		<input type="checkbox"/>

Bit fields hold True or False values and can be represented as a checkbox.

If you uncheck Allow Nulls, the column must have a value.

Some cards might have some missing information, so we'll let certain columns be blank.

Click on the Save button on the toolbar to save your new table. You'll be asked for a name. Call it "People" and click OK.

We've been talking about this table as the "People" table, but it's not until this step that you give it an official name.

This creates a People table, which goes in the ContactDB database.

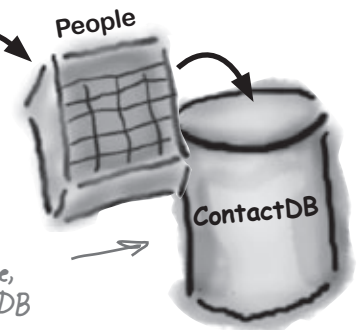

Diagram your data

The Visual Studio IDE is built to work with databases, and it comes with a lot of built-in tools that help you when you're handling a lot of data. One of the most powerful tools you have is the **database diagram**, which you can use to view and edit complex relationships between the tables in your database. So let's go ahead and build a database diagram for your database.



In very rare cases, a few people sometimes have problems getting the SQL database to work.

If you run into any trouble, don't worry—go to the Head First C# forum at <http://www.headfirstlabs.com/> for help troubleshooting the problem.

1 Create a new database diagram.

Go to the Database Explorer window and right-click on the Database Diagrams node. Select Add New Diagram.

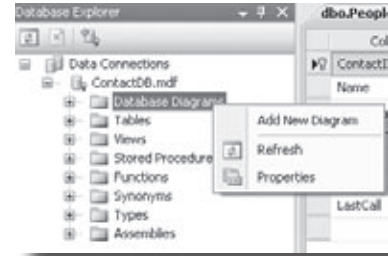

2 Let the IDE generate access code.

Before you tell the IDE about your specific table, it needs to create some basic stored procedures for interacting with your database. Just click Yes here, and let the IDE go to work.

Remember, these options are all under ContactDB, so they all apply to that specific database.



3 Select the tables you want to work with.

Select the People table from the window that pops up, and click Add. Now the IDE is ready to generate code specific to your table.

The IDE creates several stored procedures that allow your code to interact with the database you created.

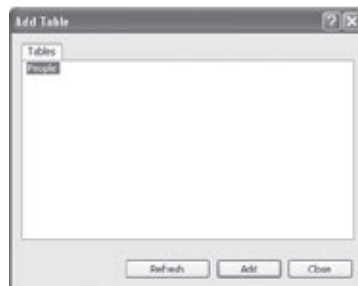

When you have databases with multiple tables, each table will show up as an entry on this window.

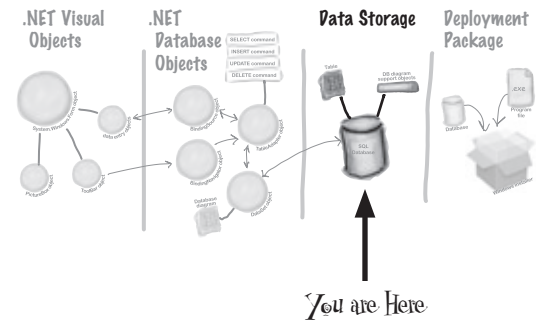

4 Name your diagram PeopleDiagram.

Select File>Save Diagram. You'll be asked to name your new database diagram. Call it PeopleDiagram, and you're all set.

If you're using Visual Studio 2005, select File>Save All instead.

The database diagram is shown here visually. It's a very simple representation of your table.

dbo.Diagram1...NTACTDB.MDF)*		dbo.People: T...ON
People		
?	ContactID	
	Name	
	Company	
	Telephone	
	Email	
	Client	
	LastCall	

This is just a picture of the database design you've just done. It marks the ContactID field as your primary key and lists off all of the columns in the table.

If you had any other tables in the database you wanted diagrammed, they would appear here, too.

A database diagram describes your tables to the Visual Studio IDE. The IDE will read your database and build a database diagram for you automatically.

Insert your card data into the database

Now you're ready to start entering cards into the database. Here are some of the boss's contacts—we'll use those to set up the database with a few records.

- 1 Expand Tables and then right click on the People Table in the Database Explorer (or Server Explorer) and select Show Table Data.
- 2 Once you see the Table grid in the main window, go ahead and add all of the data below. (You'll see all NULL values at first—just type over them when you add your first row. And ignore the exclamation points that appear next to the data.) You don't need to fill in the ContactID column, that happens automatically.

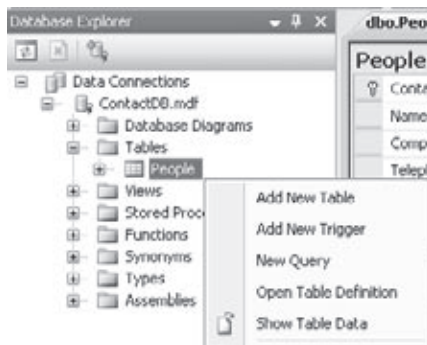

Your job is to enter the data from all six of these cards into the People table.

Type "True" or "False" in the Client column. That's how SQL stores yes or no info.

Name: Liz Nelson
Company: JTP
Telephone: (419)555-2578
Email: LizNelson@JTP.ORG
Client: Yes **Last call:** 03/04/06

Name: Lloyd Jones
Company: Black Box inc.
Telephone: (718)555-5638
Email: LJones@xblackboxinc.com
Client: Yes **Last call:** 05/26/07

Name: Lucinda Ericson
Company: Ericson Events
Telephone: (212)555-9523
Email: Lucy@ericsonevents.info
Client: NO **Last call:** 05/17/07

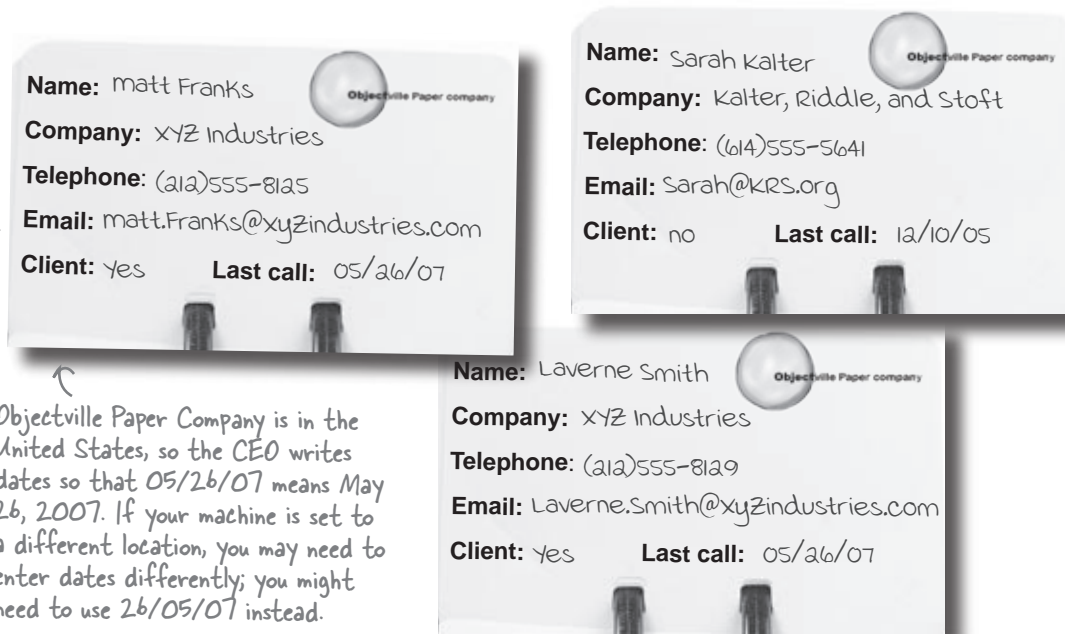

- ③ Once you've entered all six records, select Save All from the File menu again. That should save the records to the database.

"Save All" tells the IDE to save everything in your application. That's different from "Save", which just saves the file you're working on.

there are no Dumb Questions

Q: So what happened to the data after I entered it? Where did it go?

A: The IDE automatically stored the data you entered into the People table in your database. The table, its columns, the data types, and all of the data inside it is all stored in the SQL Server Express file, ContactDB.mdf. That file is stored as part of your project, and the IDE updates it just like it updates your code files when you change them.

Q: Okay, I entered these six records. Will they be part of my program forever?

A: Yes, they're as much a part of the program as the code that you write and the form that you're building. The difference is that instead of being compiled into an executable program, the ContactDB.mdf file is copied and stored along with the executable. When your application needs to access data, it reads and writes to ContactDB.mdf, in the program's output directory.

This file is actually a SQL database, and your program can use it with the code the IDE generated for you.



Connect your form to your database objects with a data source

We're finally ready to build the .NET database objects that our form will use to talk to your database. We need a **data source**, which is really just a collection of SQL statements your program will use to talk to the ContactDB database.

1 Go back to your application's form.

Close out the People table and the ContactDB database diagram. You should now have the Form1.cs [Design] tab visible.

You need to close both the data grid and the diagram to get back to your form.



2 Add a new data source to your application.

This should be easy by now. Click the Data menu, and then select Add New Data Source... from the drop down.

The data source you're creating will handle all the interactions between your form and your database.

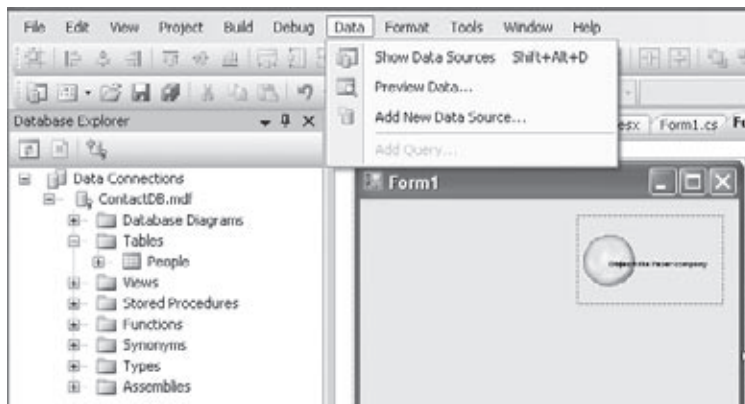

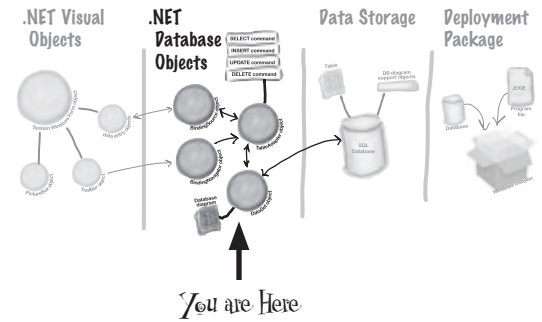

3 Configure your new data source.

Now you need to setup your data source to use the ContactDB database. Here's what to do:

- ★ Select Database and click the Next button.
- ★ Click Next in the “Choose your Data Connection” screen.
- ★ Make sure the Save the connection checkbox is checked in the “Save the Connection” screen that follows and click Next.
- ★ In the “Choose Your Objects” screen, click the Table checkbox.
- ★ In the Dataset Name field, make sure it says “ContactDBDataSet” and click Finish.

These steps connect your new data source with the People table in the ContactDB database.



Here's your existing form.

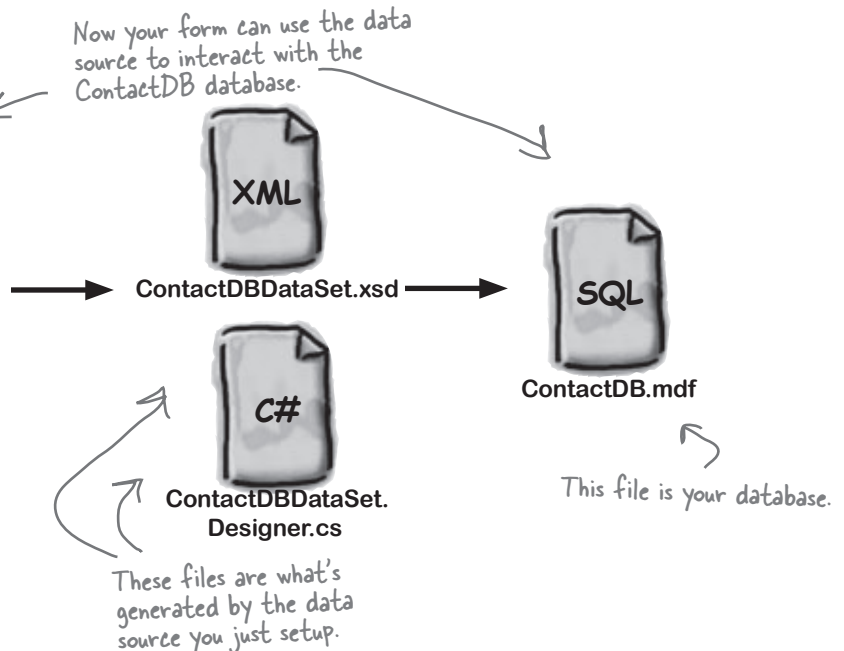

Add database-driven controls to your form

Now we can go back to our form, and add some more controls. But these aren't just any controls, they are controls that are *bound* to our database, and the columns in the People table. That just means that a change to the data in one of the controls on the form automatically changes the data in the matching column in the database.

Here's how to create several database-driven controls:

← It took a little work, but now we're back to creating form objects that interact with our data storage.

1 Select the data source you want to use.

Select Show Data Sources from the Data pull down menu. This will bring up the Data Sources window, showing the sources you have setup for your application.

If you don't see this tab, select "Show Data Sources" from the Data menu.

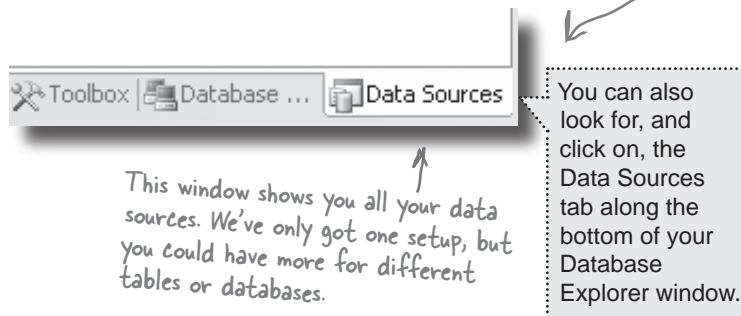

2 Select the People table.

Under the ContactDBDataSet, you should see the People table and all of the columns in it. Click the plus sign next to the People table to expand it—you'll see the columns that you added to your table. When you click on the People table in the Data Sources window and drag it onto your form, the IDE automatically adds data controls to your form that the user can use to browse and enter data. By default it adds a DataGridView, which lets the user work with the data using one big spreadsheet-like control. Click the arrow next to the People table and select Details—that tells the IDE to add individual controls to your form for each column in the table.

Click this arrow and choose Details to tell the IDE to add individual controls to your form rather than one large spreadsheet-like data control.

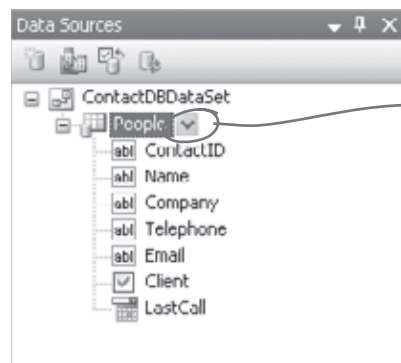

← All of the columns you created should show up here.

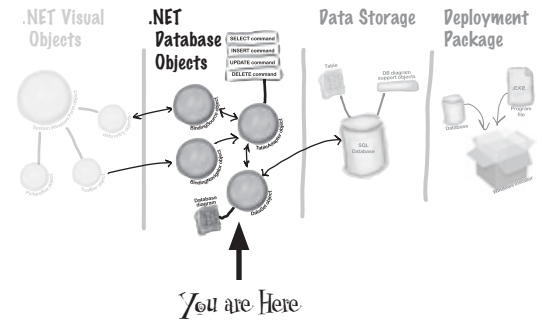

3 Create controls that bind to the People table.

Drag and drop the People table onto your form. You should see controls appear for each column in your database. Don't worry too much about how they look right now; just make sure that they all appear on the form.

If you accidentally click out of the form you're working on, you can always get back to it by clicking the "Form1.cs [Design]" tab, or opening Form1.cs from the Solution Explorer.

The screenshot shows the Visual Studio IDE with a form titled 'Form1' in Design view. The form contains several data controls: 'Contact ID', 'Name', 'Company', 'Telephone', 'Email', 'Client' (with a checkbox), and 'Last Call' (with a date field). A toolbar is visible at the top of the form, and a Solution Explorer at the bottom shows the project structure.

Annotations:

- Toolbar:** The IDE creates this toolbar for navigating through the People table.
- Form Controls:** When you dragged the People table onto the form, a control was created for each column in the table.
- contactDBDataSet:** These won't show up on your form, but represent the data set the IDE created to interact with the People table and ContactDB database.
- peopleBindingSource:** This object connects the form to your People table.
- peopleTableAdapter:** This adapter allows your controls to interact with SQL commands that the IDE and data source generated for you.
- peopleBindingNavigator:** The binding navigator connects the toolbar controls to your table.

Good programs are intuitive to use

Right now, the form works. But it doesn't look that great. Your application has to do more than be functional. It should be easy to use. With just a few simple steps, you can make the form look a lot more like the paper cards we were using at the beginning of the chapter.

Our form would be more intuitive if it looked a lot like the contact card.



1 Line up your fields and labels.

Line up your fields and labels along the left edge of the form. Your form will look like other applications, and make your users feel more comfortable using it.

Blue lines will show up on the form as you drag controls around. They're there to help you line the fields up.

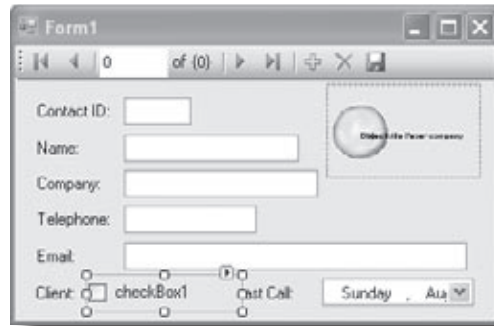

2 Change the Text Property on the Client checkbox.

When you first drag the fields onto the form your Client Checkbox will have a label to the right that needs to be deleted. Right below the Solution Explorer, you'll see the properties window. Scroll down to the Text property and delete the "checkbox1" label.

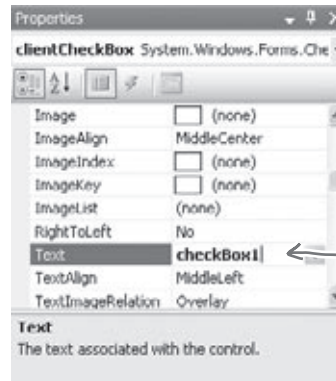

Delete this word to make the label go away.

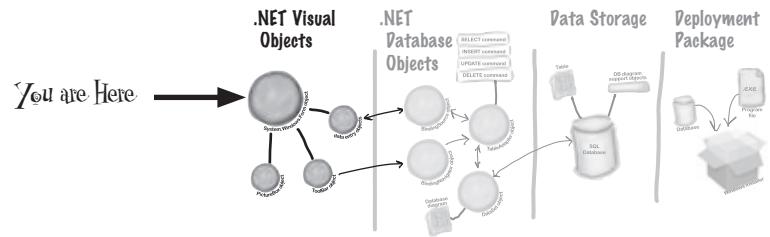

③ Make the application look professional.

You can change the name of the form by clicking on any space within the form, and finding the Text property in the Properties window of your IDE. Change the name of the form to “Objectville Paper Co. - Contact List.”

You can also turn off the Maximize and Minimize buttons in this same window, by looking for the MaximizeBox and MinimizeBox properties. Set these both to False.

The reason you want to turn off the Maximize button is that maximizing your form won't change the positions of the controls, so it'll look weird.

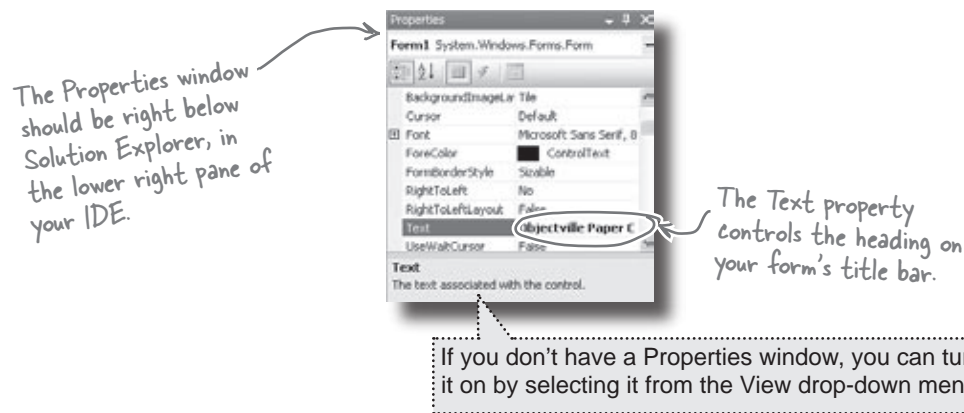

A good application not only works, but is easy to use. It's always a good idea to make sure it behaves as a typical user would expect it to.

okay, one last thing...

Test drive

Okay, just one more thing to do... run your program and make sure it works the way you think it should! Do it the same way you did before—press the F5 key on your keyboard, or click the green arrow button  on the toolbar (or choose “Run” from the Debug menu).

You can always run your programs at any time, even when they’re not done—although if there’s an error in the code, the IDE will tell you and stop you from executing it.

Click the X box in the corner to stop the program so you can move on to the next step.

Building your program overwrites the data in your database.

These controls let you page through the different records in the database.

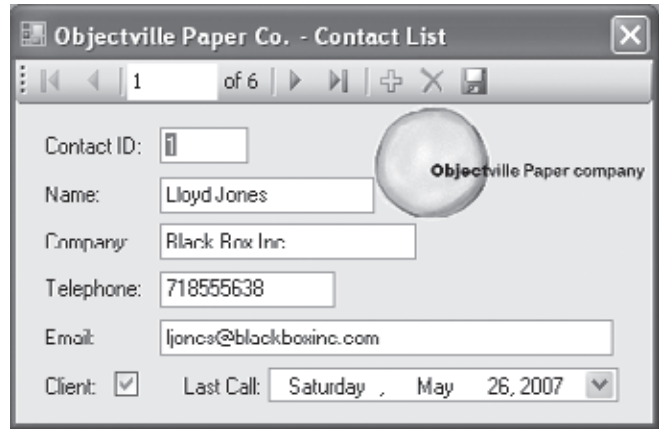

We'll spend more time on this in the next chapter.

The IDE builds first, then runs.

When you run your program in the IDE it actually does two things. First it **builds** your program, then it **executes** it. This involves a few distinct parts. It **compiles** the code, or turns it into an executable file. Then it places the compiled code, along with any resources and other files, into a subdirectory underneath the bin folder.

In this case, you'll find the executable and SQL database file in bin/debug. Since it copies the database out each time, any changes you make will be lost the next time you run inside the IDE. But if you run the executable from Windows, it'll save your data—until you build again, at which point the IDE will overwrite the SQL database with a new copy that contains the data you set up from inside the Database Explorer.



Every time you build your program, the IDE puts a fresh copy of the database in the bin

folder. This will overwrite any data you added when you ran the program.

When you debug your program, the IDE rebuilds it if the code has changed—which means that your database will sometimes get overwritten when you run your program in the IDE. If you run the program directly from the bin/debug or bin/release folder, or if you use the installer to install it on your machine, then you won't see this problem.

How to turn YOUR application into EVERYONE'S application

At this point, you've got a great program. But it only runs on your machine. That means that nobody else can use the app, pay you for it, see how great you are and hire you... and your boss and customers can't see the reports you're generating from the database.

C# makes it easy to take an application you've created, and **deploy** it. Deployment is taking an application and installing it onto other machines. And with the Visual C# IDE, you can set up a deployment with just two steps.

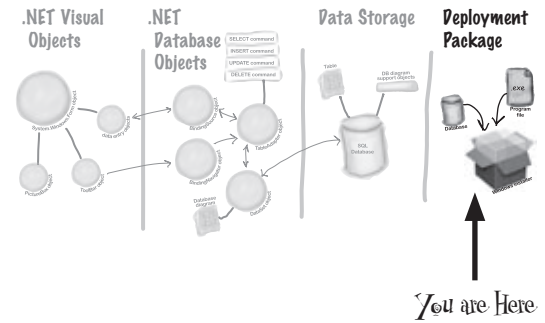

1

Select *Publish Contacts* from the Build menu.

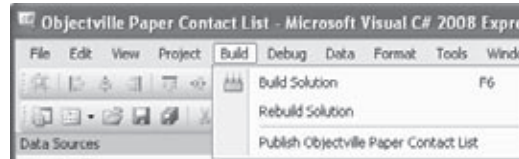

Building the solution just copies the files to your local machine. Publish creates a Setup executable and a configuration file so that any machine could install your program.

2

Just accept all of the defaults in the Publish Wizard by clicking Finish. You'll see it package up your application and then show you a folder that has your Setup.exe in it.



Give your users the application

Once you've created a deployment, you'll have a new folder called `publish/`. That folder has several things in it, all used for installation. The most important for your users is `setup`, a program that will let them install your program on their own computers.

This is where all of the supporting files for the installer are stored.

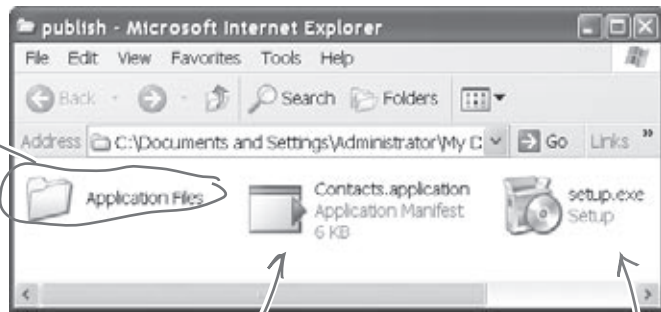

This file tells the installer everything that needs to be included when the program is installed.

This is how your users will install the program on their computers!

My secretary just told me that you've got the new contact database working already. Pack your bags—we've got room on the jet to Aspen for a go-getter like you!



Sounds like the boss is pleased. Good job! There's just one more thing to do before you can jet off to the slopes, though...

You're NOT done: test your installation

Before you pop the cork on any champagne bottles, you need to test your deployment and installation. You wouldn't give anyone your program without running it first, would you?

Close the Visual Studio IDE. Click the setup program, and select a location on your own computer to install the program. Now run it from there, and make sure it works like you expect. You can add and change records, too, and they'll be saved to the database.

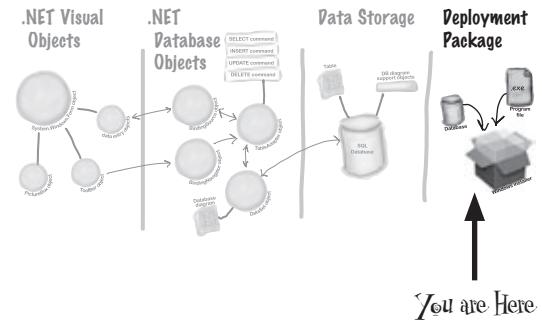

Now you can add, change, and delete records, and they'll get saved to the database.

You can use the arrows and the text field to switch between records.

Go ahead...make some changes. You've deployed it so this time, they'll stick.

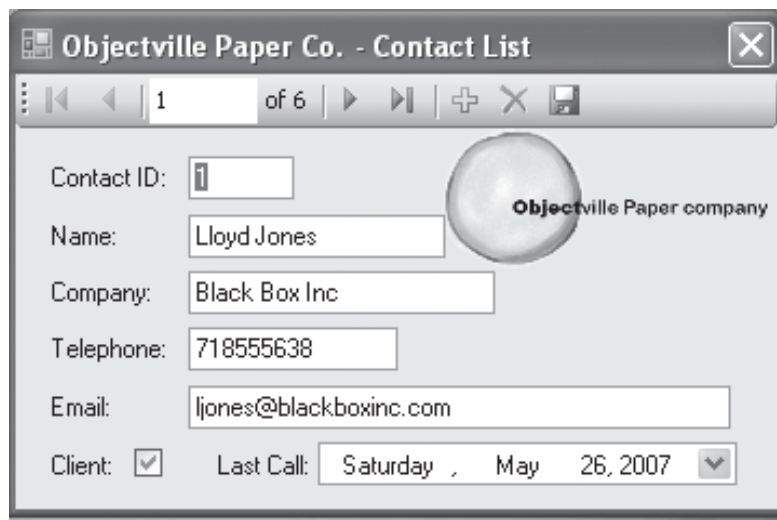

The six records you initially entered are all there. They're part of the ContactDB.mdf database file, which gets installed along with your program.

TEST EVERYTHING!

Test your program, test your deployment, test the data in your application.

super fast!

You built a complete data-driven application

The Visual Studio IDE made it pretty easy to create a Windows application, create and design a database, and hook the two together. You even were able to build an installer with a few extra clicks.

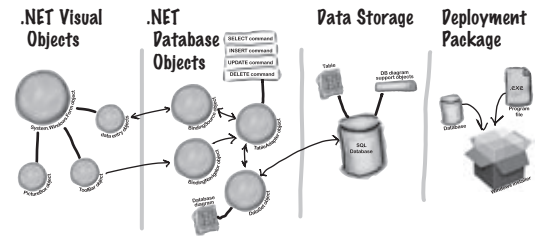

From this



to this

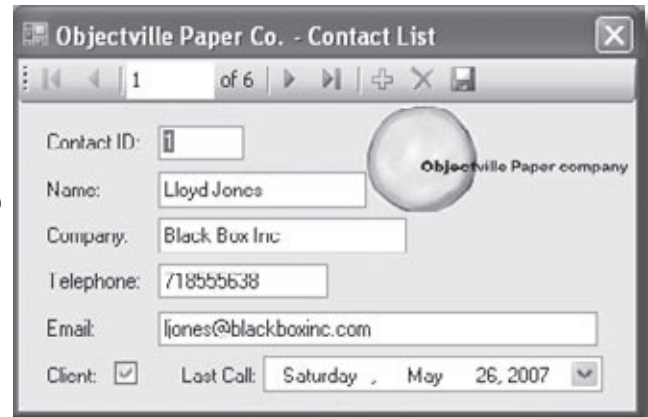

in no time flat.

The power of Visual C# is that you can quickly get up and running, and then focus on your what your program's supposed to do... not lots of windows, buttons, and SQL access code.



C# Sharpcross

Take some time to sit back and exercise your C# vocabulary with this crossword; all of the solution words are from this chapter.

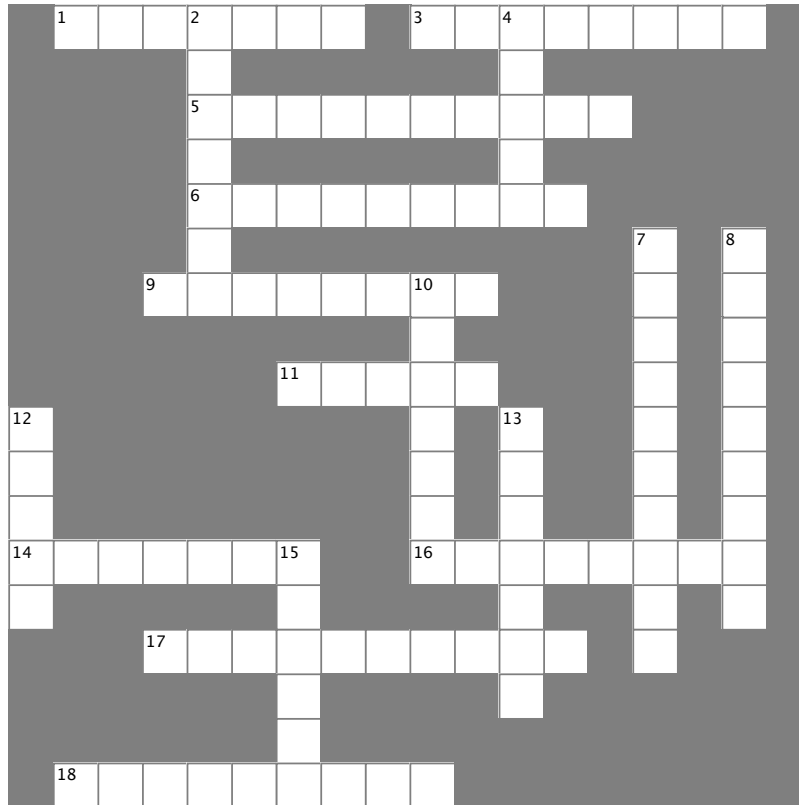

Across

1. When you do this from inside the IDE, it's called "debugging".
3. The _____ explorer is where you edit the contents of your SQL tables and bind them to your program.
5. The "About" box in the Contact List program was one of these.
6. You build one of these so you can deploy your program to another computer.
9. An image, sound, icon or file that's attached to your project in a way that your objects can access easily.
11. Before you can run your program, the IDE does this to create the executable and move files to the output directory.
14. The database _____ gives the IDE information about your database so it can generate SQL statements automatically.
16. The _____ explorer in the IDE is where you'll find the files in your project.
17. Drag one of these objects onto your form to display an image.
18. A stored _____ is a way for a SQL database to save queries and statements that you can reuse later.

Down

2. What's happening when code is turned into an executable.
4. A SQL database can use many of these to store its data.
7. What you change to alter the appearance or behavior of objects on your form.
8. What you're doing to your program when you run it from inside the IDE.
10. Every row in a database contains several of these, and all of them can have different data types.
12. Before you start building any application, always think about the users and their _____.
13. You drag objects out of this and onto your form.
15. When you double-clicked on a visual control, the IDE created this for you and you added code to it.



CSharpcross Solution

¹ E X E			² C U T E				³ D A		⁴ T A B A S E					
			O					A						
			⁵ M E S S A G E					B O X						
			P					L						
			⁶ I N S T A L L E R											
			L							⁷ P		⁸ D		
		⁹ R E S O U R					¹⁰ C E				R		E	
						O				O		B		
				¹¹ B U I L D						P		U		
¹² N						U		¹³ T		E		G		
E						M		O		R		G		
E						N		O		T		I		
¹⁴ D	I	A	G	R	A	¹⁵ M		¹⁶ S O L U T I O N						
S					E			B		E		G		
		¹⁷ P I C T U R E							B O X		S			
					H			X						
					O									
¹⁸ P	R	O	C	E	D	U	R	E						

2 it's all just code

* Under the Hood *

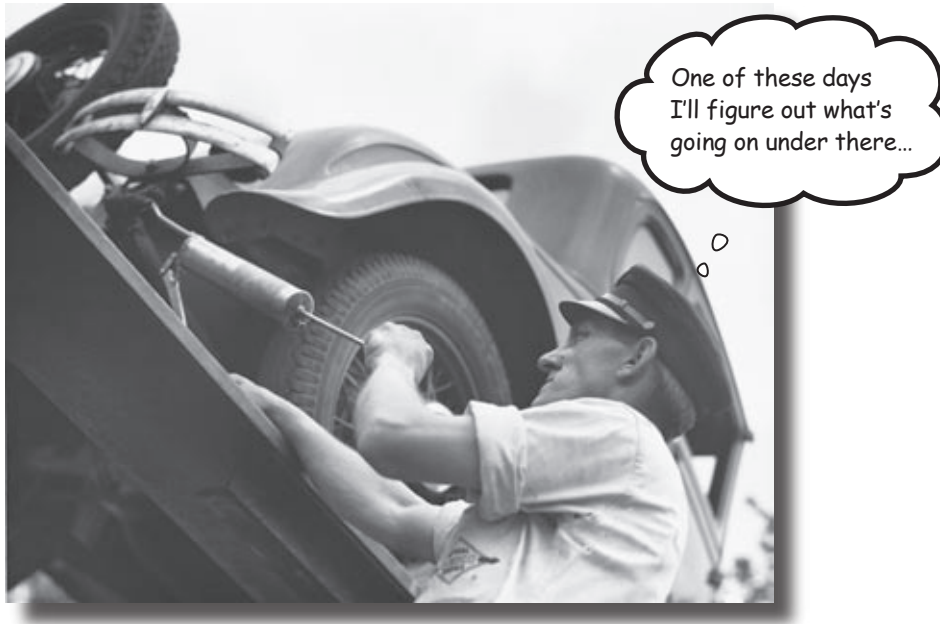

You're a programmer, not just an IDE-user.

You can get a lot of work done using the IDE. But there's only so far it can take you. Sure, there are a lot of **repetitive tasks** that you do when you build an application. And the IDE is great at doing those things for you. But working with the IDE is *only the beginning*. You can get your programs to do so much more—and **writing C# code** is how you do it. Once you get the hang of coding, there's *nothing* your programs can't do.

When you're doing this...

The IDE is a powerful tool—but that's all it is, a *tool* for you to use. Every time you change your project or drag and drop something in the IDE, it creates code automatically. It's really good at writing **boilerplate** code, or code that can be reused easily without requiring much customization.

Let's look at what the IDE does in typical application development, when you're...

All of these tasks have to do with standard actions, and boilerplate code. Those are the things the IDE is great for helping with.

1 Creating a new Windows Application solution

There are several kinds of applications the IDE lets you build, but we'll be concentrating on Windows applications for now. Those are programs that have visual elements, like forms and buttons.

Make sure you always create a Windows Forms Application project—that tells the IDE to create an empty form and add it to your new project.

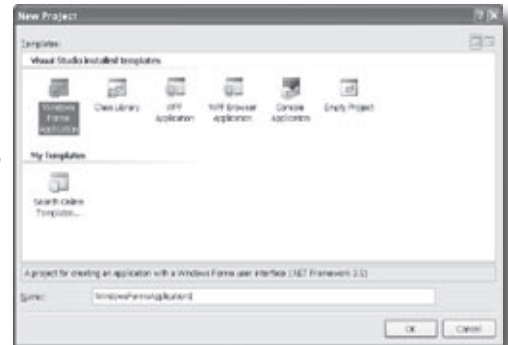

2 Dragging a button out of the toolbox and onto your form, and then double-clicking it

Buttons are how you make things happen in your form. We'll use a lot of buttons to explore various parts of the C# language. They're also a part of almost every C# application you'll write.

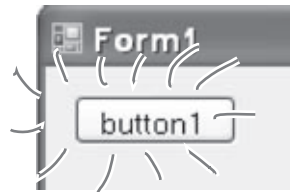

3 Setting a property on your form

The **Properties window** in the IDE is a really powerful tool that you can use to change attributes of just about everything in your program: all visual and functional properties for the controls on your form, attributes of your databases, and even options on your project itself.

The Properties window in the IDE is a really easy way to edit a specific chunk of code in `Form1.Designer.cs` automatically. It would take a lot longer to do it by hand.

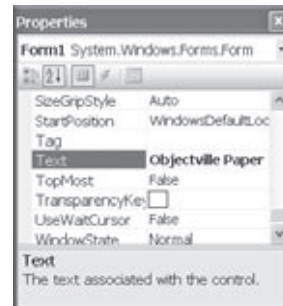

...the IDE does this

Every time you make a change in the IDE, it makes a change to the code, which means it changes the files that contain that code. Sometimes it just modifies a few lines, but other times it adds entire files to your project.

- 1 ... the IDE creates the files and folders for the project.



These files are created from a predefined template that contains the basic code to create and display a form.

- 2 ... the IDE adds code to the Form1.Designer.cs file that adds the button to the form, and then adds code to the Form1.cs file to handle the button click.

```
private void button1_Click(object sender, EventArgs e)
{
}

```

The IDE knows how to add an empty method to handle a button click. But it doesn't know what to put inside it—that's your job.

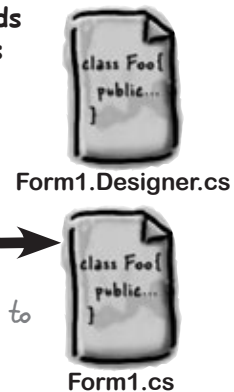

- 3 ... the IDE opens the Form1.Designer.cs file and updates a line of code.

```
partial class Form1
{
:
:
:
}

```

this.Text = "Objectville Paper Company contact list";

...and updated this line of code.

The IDE went into this file...

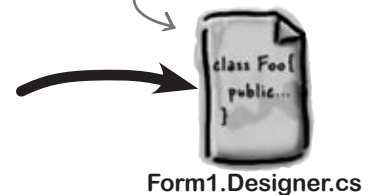

Where programs come from

A C# program may start out as statements in a bunch of files, but it ends up as a program running in your computer. Here’s how it gets there.

Every program starts out as source code files

You’ve already seen how to edit a program, and how the IDE saves your program to files in a folder. Those files **are** your program—you can copy them to a new folder and open them up, and everything will be there: forms, resources, code, and anything else you added to your project.

You can think of the IDE as a kind of fancy file editor. It automatically does the indenting for you, changes the colors of the keywords, matches up brackets for you, and even suggests what words might come next. But in the end, all the IDE does is edit the files that contain your program.

The IDE bundles all of the files for your program into a **solution** by creating a solution (.sln) file and a folder that contains all of the other files for the program. The solution file has a list of the project files (which end in .csproj) in the solution, and the project files contain lists of all the other files associated with the program. In this book, you’ll be building solutions that only have one project in them, but you can easily add other projects to your solution using the IDE’s Solution Explorer.



There’s no reason you couldn’t build your programs in Notepad, but it’d be a lot more time-consuming.

The .NET Framework gives you the right tools for the job

C# is just a language—by itself, it can’t actually **do** anything. And that’s where the **.NET Framework** comes in. Remember that Maximize button you turned off for the Contacts form? When you click the Maximize button on a window, there’s code that tells the window how to maximize itself and take up the whole screen. That code is part of the .NET Framework. Buttons, checkboxes, lists... those are all pieces of the .NET framework. So are the internal bits that hooked your form up to the database. It’s got tools to draw graphics, read and write files, manage collections of things... all sorts of tools for a lot of jobs that programmers have to do every day.



The tools in the .NET Framework are divided up into **namespaces**. You’ve seen these namespaces before, at the top of your code in the “using” lines. One namespace is called System.Windows.Forms—it’s where your buttons, checkboxes, and forms come from. Whenever you create a new Windows Forms Application project, the IDE will add the necessary files so that your project contains a form, and those files have the line “using System.Windows.Forms;” at the top.

Build the program to create an executable

When you select “Build Solution” from the Build menu, the IDE **compiles** your program. It does this by running the **compiler**, which is a tool that reads your program’s source code and turns it into an **executable**. The executable is a file on your disk that ends in `.exe`—that’s what you double-click on to run your program. When you build the program, it creates the executable inside the `bin` folder, which is inside the project folder. When you publish your solution, it copies the executable (and any other files necessary) into the folder you’re publishing to.

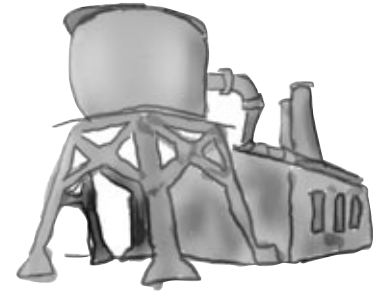

When you select “Start Debugging” from the Debug menu, the IDE compiles your program and runs the executable. It’s got some more advanced tools for **debugging** your program, which just means running it and being able to pause (or “break”) it so you can figure out what’s going on.

Your program runs inside the CLR

When you double-click on the executable, Windows runs your program. But there’s an extra “layer” between Windows and your program called the **Common Language Runtime**, or CLR. Once upon a time, not so long ago (but before C# was around), writing programs was harder, because you had to deal with hardware and low-level machine stuff. You never knew exactly how someone was going to configure his computer. The CLR—often referred to as a **virtual machine**—takes care of all that for you by doing a sort of “translation” between your program and the computer running it.

You’ll learn about all sorts of things the CLR does for you. For example, it tightly manages your computer’s memory by figuring out when your program is finished with certain pieces of data and getting rid of them for you. That’s something programmers used to have to do themselves, and it’s something that you don’t have to be bothered with. You won’t know it at the time, but the CLR will make your job of learning C# a whole lot easier.



You don’t really have to worry about the CLR much right now. It’s enough to know it’s there, and takes care of running your program for you automatically. You’ll learn more about it as you go.

The IDE helps you code

You've already seen a few of the things that the IDE can do. Let's take a closer look at some of the tools it gives you.



The Solution Explorer shows you everything in your project

You'll spend a lot of time going back and forth between classes, and the easiest way to do that is to use the solution explorer. It's got two views: a Solution Explorer view (which shows you the files in your project) and a Class View (which shows you how your code logically breaks down into classes).

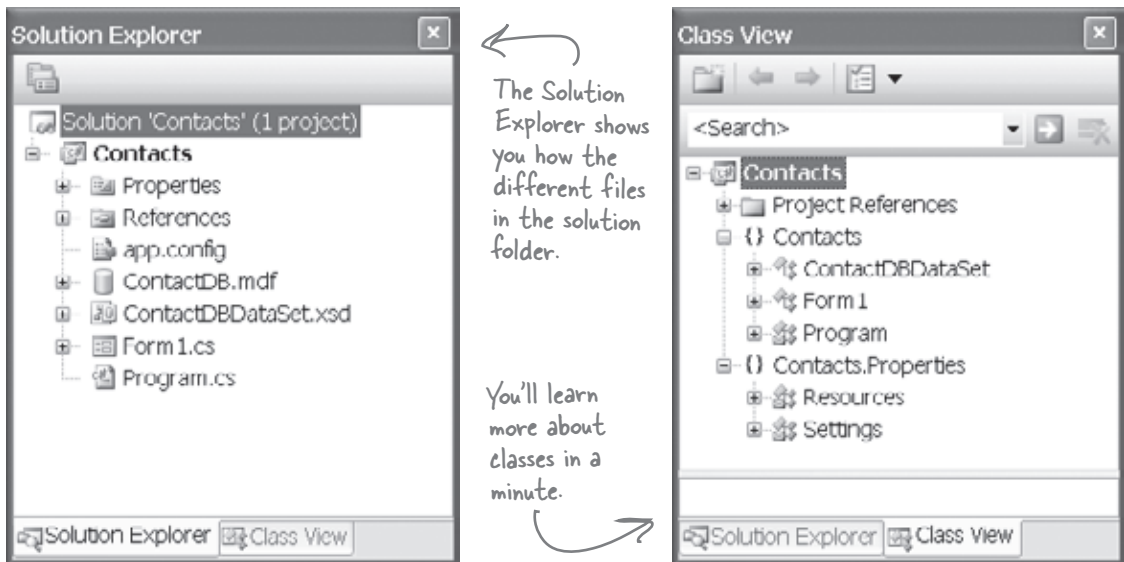

Use the tabs to switch between open files

Since your program is split up into more than one file, you'll usually have several code files open at once. When you do, each one will be in its own tab in the code editor. The IDE displays an asterisk (*) next to a filename if it hasn't been saved yet.

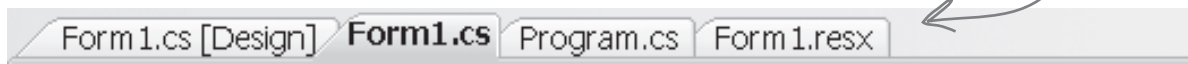

When you're working on a form, you can have two tabs for it at the same time—one for the form designer, and one to view the form's code.

★ **The IDE helps you write code**

Did you notice little windows popping up as you typed code into the IDE? That's a feature called IntelliSense, and it's really useful. One thing it does is show you possible ways to complete your current line of code. If you type `MessageBox` and then a period, it knows that there are three valid ways to complete that line:

`MessageBox.`

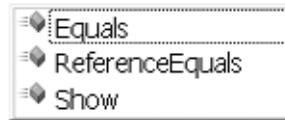

The IDE knows that `MessageBox` has three methods called `Equals`, `ReferenceEquals`, and `Show`. If you type `S`, it selects `Show`. Press the `Tab` or `Enter` key to tell the IDE to fill it in for you. That can be a real timesaver if you're typing a lot of really long method names.

If you select `Show` and type `(`, the IDE's IntelliSense will show you information about how you can complete the line:

This means that there are 21 different ways that you can call the `MessageBox`'s `Show` method (like ways to display different buttons or icons).

`MessageBox.Show (`

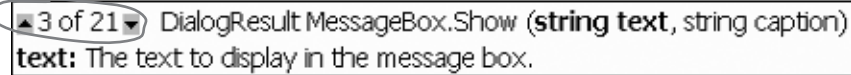

The IDE also has shortcuts called **snippets** that let you type an abbreviation to tell it to fill in the rest of the code. Here's a useful one: type `mbox` and press the `tab` key twice, and the IDE will fill in the `MessageBox.Show` method for you:

`MessageBox.Show ("Test ");`

When you use `Start Debugging` to run your program inside the IDE, the first thing it does is build your program. If it compiles, then your program runs. If not, it won't run, and will show you errors in the `Error List`.

★ **The Error List helps you troubleshoot compiler errors**

If you haven't already discovered how easy it is to make typos in a C# program, you'll find out very soon! Luckily, the IDE gives you a great tool for troubleshooting them. When you build your solution, any problems that keep it from compiling will show up in the `Error List` window at the bottom of the IDE:

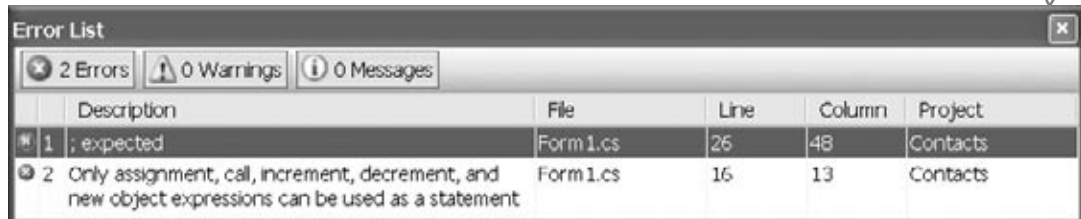

Double-click on an error, and the IDE will jump to the problem in the code:

```
private void pictureBox1_Click(object sender, EventArgs e)
{
    MessageBox.Show("Contact List 1.0");
}
```

The IDE will show a red underscore where it finds you're missing a semicolon.

you are here ▶

When you change things in the IDE, you're also changing your code

The IDE is great at writing visual code for you. But don't take our word for it. Open up Visual Studio, **create a new Windows Application project**, and see for yourself.

When you see a "Do this!", pop open the IDE and follow along. We'll tell you exactly what to do, and point out what to look for to get the most out of the example we show you.

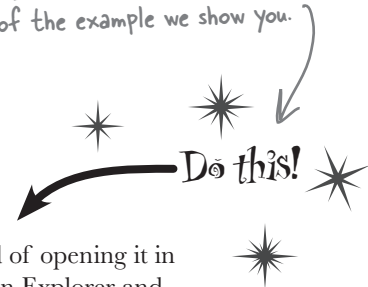

1 Open up the designer code

Open the `Form1.Designer.cs` file in the IDE. But this time, instead of opening it in the Form Designer, open up its code by right-clicking on it in the Solution Explorer and selecting "View Code". Look for the `Form1` class declaration:

```
partial class Form1
```

Notice how it's a partial class?

2 Open up the Form designer and add a PictureBox to your form

Get used to working with more than one tab. Go to the Solution Explorer and open up the Form designer by double-clicking on `Form1.cs`. **Drag a new PictureBox** onto a new form.

3 Find and expand the designer-generated code for the PictureBox control

Then go back to the `Form1.Designer.cs` tab in the IDE. Scroll down and look for this line in the code:

```
Windows Form Designer generated code
```

Click on the plus sign

Click on the + on the left-hand side of the line to expand the code. Scroll down and find these lines:

```
//  
// pictureBox1  
//  
this.pictureBox1.Location = new System.Drawing.Point(276, 28);  
this.pictureBox1.Name = "pictureBox1";  
this.pictureBox1.Size = new System.Drawing.Size(100, 50);  
this.pictureBox1.TabIndex = 1;  
this.pictureBox1.TabStop = false;
```

Don't worry if the numbers in your code for the Location and Size lines are a little different than these...

Wait, wait! What did that say?

Scroll back up for a minute. There it is, at the top of the Windows Form Designer generated code section.

```
/// <summary>
/// Required method for Designer support - do not modify
/// the contents of this method with the code editor.
/// </summary>
```

Most comments only start with two slashes (//). But the IDE sometimes adds these three-slash comments.

There's nothing more attractive to a kid than a big sign that says, "Don't touch this!" Come on, you know you're tempted... let's go modify the contents of that method with the code editor! **Add a button to your form, and then go ahead and do this:**

- 1 **Change the code that sets the `button1.Text` property. What do you think it will do to the Properties window in the IDE?**
Give it a shot—see what happens! Now go back to the form designer and check the Text property. Did it change?
- 2 **Stay in the designer, and use the Properties window to change the Name property to something else.**
See if you can find a way to get the IDE to change the Name property. It's in the Properties window at the very top, under "(Name)". What happened to the code? What about the comment in the code?
- 3 **Change the code that sets the Location property to (0,0) and the Size property to make the button really big.**
Did it work?
- 4 **Go back to the designer, and change the button's BackColor property to something else.**
Look closely at the `Form1.Designer.cs` code. Were any lines added?

You don't have to save the form or run the program to see the changes. Just make the change in the code editor, and then click on the tab labeled "Form1.cs [Design]" to flip over to the form designer—the changes should show up immediately.

It's always easier to use the IDE to change your form's Designer-generated code. But when you do, any change you make in the IDE ends up as a change to your projects' code.

your program makes a statement

Anatomy of a program

Every C# program's code is structured in exactly the same way. All programs use **namespaces**, **classes**, and **methods** to make your code easier to manage.

A class contains a piece of your program (although some very small programs can have just one class).

A class has one or more methods. Your methods always have to live inside a class. And methods are made up of statements—like the ones you've already seen.

Every time you make a new program, you define a namespace for it so that its code is separate from the .NET Framework classes.

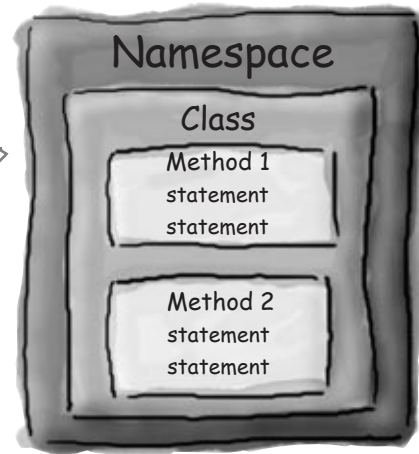

Let's take a closer look at your code

Open up the code from your Contact project's `Form1.cs` so we can go through it piece by piece.

1 The code file starts by using the .NET Framework tools

You'll find a set of `using` lines at the top of every program file. They tell C# which parts of the .NET Framework to use. If you use other classes that are in other namespaces, then you'll add `using` lines for them too. Since forms often use a lot of different tools from the .NET Framework, the IDE automatically adds a bunch of `using` lines when it creates a form and adds it to your project.

```
using System;  
using System.Collections.Generic;  
using System.ComponentModel;  
using System.Data;  
using System.Drawing;  
using System.Linq;  
using System.Text;  
using System.Windows.Forms;
```

These `using` lines are at the top of every code file. They tell C# to use all of those .NET Framework classes. Each one tells your program that the classes in this particular .cs file will use all of the classes in one specific .NET Framework namespace.

You'll see slightly different `using` lines if you're using Visual Studio 2005.

2 C# programs are organized into classes

Every C# program is organized into **classes**. A class can do anything, but most classes do one specific thing. When you created the new program, the IDE added a class called Form1 that displays a form.

namespace Contacts

When you called your program Contacts, the IDE created a namespace for it called Contacts by adding the namespace keyword at the top of your code file. Everything inside its pair of curly brackets is part of the Contacts namespace.

{

public partial class Form1 : Form

{

This is a class called Form1. It contains all of the code to draw the form and the Toolbox controls on it. The IDE created it when you told it to create a new Windows Forms Application project.

3 Classes contain methods that perform actions

When a class needs to do something, it uses a **method**. A method takes an input, performs some action, and sometimes produces an output. The way you pass input into a method is by using **parameters**. Methods can behave differently depending on what input they're given. Some methods produce output. When they do, it's called a **return value**. If you see the keyword **void** in front of a method, that means it doesn't return anything.

Look for the matching pairs of brackets. Every { is eventually paired up with a }. Some pairs can be inside others.

public Form1()

{

InitializeComponent();

}

This line calls a method named InitializeComponent(), which the IDE also created for you.

4 A statement performs one single action

When you added the `MessageBox.Show()` line to your program, you were adding a **statement**. Every method is made up of statements. When your program calls a method, it executes the first statement in the method, then the next, then the next, etc. When the method runs out of statements or hits a **return** statement, it ends, and the program resumes after the statement that originally called the method.

This is a method called `pictureBox1_Click()` that gets called when the user clicks on the picture box.

This method has two parameters called `sender` and `e`.

private void pictureBox1_Click(object sender, EventArgs e)

{

MessageBox.Show("Contact List 1.0", "About");

}

This is a **statement**. You already know what it does—it pops up a little message box window.

Your statement called the `Show()` method, which is part of the `MessageBox` class, which is inside the `System.Windows.Forms` namespace.

Your statement passed two parameters to the `Show()` method. The first one was a string of text to display in the message box, and the second one was a string to display in its title bar.

}

Your program knows where to start

When you created the new Windows Application solution, one of the files the IDE added was called **Program.cs**. Go to the Solution Explorer and double-click on it. It's got a class called Program, and inside that class is a method called Main(). That method is the **entry point**, which means that it's the very first thing that's run in your program.

Every C# program can only have one entry point method, and it's always called Main(). That's how it knows where to start when you run it.



Your Code Up Close

Here's some code the IDE built for you automatically in the last chapter. You'll find it in Program.cs.

```
1 using System;
using System.Linq;
using System.Collections.Generic;
using System.Windows.Forms;

2 namespace Contacts
{
3     static class Program
    {
        /// <summary>
        /// The main entry point for the application.
        /// </summary>
        [STAThread]
        static void Main()
        {
            Application.EnableVisualStyles();
            4 Application.SetCompatibleTextRenderingDefault(false);
            Application.Run(new Form1());
        }
    }
}
```

The namespace for all this code is Contacts. We'll talk about namespaces more in a few pages.

Lines that begin with slashes are comments, which you can add anywhere you want. The slashes tell C# to ignore them.

Every time you run your program, it starts here, at the entry point.

This statement creates and displays the Contacts form, and ends the program when the form's closed.

I do declare!
The first line of every class or method is called the declaration.

Remember, this is just a starting point for you to dig into the code. But before you do, you'll need to know what you're looking at.

1 C# and .NET have lots of built-in features.

You'll find lines like this at the top of almost every C# class file. `System.Windows.Forms` is a **namespace**. The using `System.Windows.Forms` line makes everything in that namespace available to your program. In this case, that namespace has lots of visual elements in it like buttons and forms.

Your programs will use more and more namespaces like this one as you learn about C# and .NET's other built-in features throughout the book.

2 The IDE chose a namespace for your code.

Here's the namespace the IDE created for you—it chose `Contacts` based on your project's name. All of the code in your program lives in this namespace.

Namespaces let you use the same name in different programs, as long as those programs aren't also in the same namespace.

3 Your code is stored in a class.

This particular class is called `Program`. The IDE created it and added the code that starts the program and brings up the `Contacts` form.

You can have multiple classes in a single namespace.

4 This code has one method, and it contains three statements.

A namespace has classes in it, and classes have methods. Inside each method is a set of statements. In this program, the statements handle starting up the `Contacts` form. Methods are where the action happens—every method **does** something.

Technically, a program can have more than one `Main()` method, and you can tell C# which one is the entry point... but you won't need to do that now.

5 Each program has a special kind of method called the entry point.

Every C# program **must** have exactly one method called `Main`. Even though your program has a lot of methods, only one can be the first one that gets executed, and that's your `Main` method. C# checks every class in your code for a method that reads `static void Main()`. Then, when the program is run, the first statement in this method gets executed, and everything else follows from that first statement.

Every C# program must have exactly one method called `Main`. That method is the entry point for your code.

When you run your code, the code in your `Main()` method is executed **FIRST.**

You can change your program's entry point

As long as your program has an entry point, it doesn't matter which class your entry point method is in, or what that method does. **Open up the program you wrote in Chapter 1**, remove the `Main` method in `Program.cs`, and create a new entry point.



Write down what happened when you changed the method name, and why you think that happened.

- 1 Go back to `Program.cs` and change the name of the `Main` method to `NotMain`. Now **try to build and run** the program. What happens?

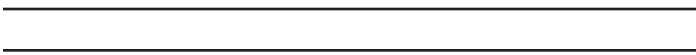

Right-click on the project in Properties and select "Add" and "Class..."

- 2 Now let's create a new entry point. **Add a new class** called `AnotherClass.cs`. You add a class to your program by right-clicking on the project name in the Solution Explorer and selecting "Add>>Class...". Name your class file `AnotherClass.cs`. The IDE will add a class to your program called `AnotherClass`. Here's the file the IDE added:

```
using System;
using System.Linq;
using System.Collections.Generic;
using System.Text;

namespace Contacts
{
    class AnotherClass
    {
    }
}
```

These four standard using lines were added to the file.

This class is in the same `Contacts` namespace that the IDE added when you first created the Windows Application project.

The IDE automatically named the class based on the filename.

- 3 Add a new using line to the top of the file: **using System.Windows.Forms**; Don't forget to end the line with a semicolon!

- 4 Add this method to the **AnotherClass** class by typing it in between the curly brackets:

`MessageBox` is a class that lives in the `System.Windows.Forms` namespace, which is why you had to add the using line in step #3. `Show()` is a method that's part of the `MessageBox` class.

```
class AnotherClass
{
    public static void Main()
    {
        MessageBox.Show("Pow!");
    }
}
```

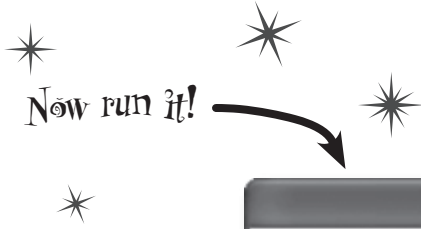

So what happened?

Instead of popping up the Contacts application, your program now shows this MessageBox. When you made the new Main() method, you gave your program a new entry point. Now the first thing the program does is run the statements in that method—which means running that MessageBox.Show() statement. There's nothing else in that method, so once you click the OK button, the program runs out of statements to execute and then it ends.

- 5 Figure out how to fix your program so it pops up Contacts again.

Hint: you only have to change two lines in two files to do it.

Sharpen your pencil

Fill in the annotations so they describe the lines in this C# file that they're pointing to. We've filled in the first one for you.

```
using System;
using System.Linq;
using System.Text;
using System.Windows.Forms;
```

C# classes have these "using" lines to add methods from other namespaces

```
namespace SomeNamespace .....
{
    class MyClass {
        public static void DoSomething() {
            MessageBox.Show("This is a message");
        }
    }
}
```

there are no Dumb Questions

Q: What's with all the curly brackets?

A: C# uses curly brackets (or "braces") to group statements together into **blocks**. Curly brackets always come in pairs. You'll only see a closing curly bracket after you see an opening one. The IDE helps you match up curly brackets—just click on one, and you'll see it and its match get shaded darker.

Q: I don't quite get what the entry point is. Can you explain it one more time?

A: Your program has a whole lot of statements in it, but they're not all run at once. The program starts with the first statement in the program, executes it, and then goes on to the next one, and the next one, etc. Those statements are usually organized into a bunch of classes. So when you run your program, how does it know which statement to start with?

That's where the entry point comes in. The compiler will not build your code unless there is **exactly one method called Main()** which we call the entry point. The program starts running with the first statement in Main().

Q: How come I get errors in the Error List window when I try to run my program? I thought that only happened when I did "Build Solution."

A: Because the first thing that happens when you choose "Start Debugging" from the menu or press the toolbar button to start your program running is that it saves all the files in your solution and then tries to compile them. And when you compile your code—whether it's when you run it, or when you build the solution—if there are errors, the IDE will display them in the Error List instead of running your program.

Sharpen your pencil Solution

Fill in the annotations so they describe the lines in this C# file that they're pointing to. We've filled in the first one for you.

```
using System;
using System.Linq;
using System.Text;
using System.Windows.Forms;
```

C# classes have these "using" lines to add methods from other namespaces.

```
namespace SomeNamespace
```

All of the code lives in classes, so the program needs a class here.

```
{
```

```
    class MyClass {
```

This is a method. Every method in the program does something. Methods are used to group statements together.

```
        public static void DoSomething() {
```

```
            MessageBox.Show("This is a message");
```

This is a statement. When it's executed, it pops up a little window with a message inside of it.

```
        }
```

```
    }
```

```
}
```

WHAT'S MY PURPOSE?

Match each of these fragments of code generated by the IDE to what it does.
(Some of these are new—take a guess and see if you got it right!)

```
partial class Form1
{
    :
    this.BackColor = Color.DarkViolet;
    :
}
```

Set properties for a label

```
// This loop gets executed three times
```

Nothing—it's a comment that the programmer added to explain the code to anyone who's reading it

```
partial class Form1
{
    private void InitializeComponent()
    {
    }
}
```

Disable the maximize icon () in the title bar of the Form1 window

```
number_of_pit_stopsLabel.Name
    = "number_of_pit_stopsLabel";
number_of_pit_stopsLabel.Size
    = new System.Drawing.Size(135, 17);
number_of_pit_stopsLabel.Text
    = "Number of pit stops:";
```

A special kind of comment that the IDE uses to explain what an entire block of code does

```
/// <summary>
/// Bring up the picture of Rover when
/// the button is clicked
/// </summary>
```

Change the background color of the Form1 window

```
partial class Form1
{
    :
    this.MaximizeBox = false;
    :
}
```

A block of code that executes whenever a program opens up a Form1 window

+ WHAT'S MY PURPOSE? +

Match each of these fragments of code generated by the IDE to what it does.
(Some of these are new—take a guess and see if you got it right!)

```
partial class Form1
{
    :
    this.BackColor = Color.DarkViolet;
    :
}
```

```
// This loop gets executed three times
```

```
partial class Form1
{
    private void InitializeComponent()
    {
        :
    }
}
```

```
number_of_pit_stopsLabel.Name
    = "number_of_pit_stopsLabel";
number_of_pit_stopsLabel.Size
    = new System.Drawing.Size(135, 17);
number_of_pit_stopsLabel.Text
    = "Number of pit stops:";
```

```
/// <summary>
/// Bring up the picture of Rover when
/// the button is clicked
/// </summary>
```

```
partial class Form1
{
    :
    this.MaximizeBox = false;
    :
}
```

Set properties for a label

Nothing—it's a comment that the programmer added to explain the code to anyone who's reading it

Disable the maximize icon (☐) in the title bar of the Form1 window

A special kind of comment that the IDE uses to explain what an entire block of code does

Change the background color of the Form1 window

A block of code that executes whenever a program opens up a Form1 window

Two classes can be in the same namespace

Take a look at these two class files from a program called PetFiler2. They've got three classes: a Dog class, a Cat class, and a Fish class. Since they're all in the same PetFiler2 namespace, statements in the Dog.Bark() method can call Cat.Meow() and Fish.Swim(). It doesn't matter how the various namespaces and classes are divided up between files. They still act the same when they're run.

When a class is "public" it means every other class in the program can access its methods.

MoreClasses.cs

```
namespace PetFiler2 {
    public class Fish {
        public void Swim() {
            // statements
        }
    }
    public partial class Cat {
        public void Purr() {
            // statements
        }
    }
}
```

SomeClasses.cs

```
namespace PetFiler2 {
    public class Dog {
        public void Bark() {
            // statements go here
        }
    }
    public partial class Cat {
        public void Meow() {
            // more statements
        }
    }
}
```

Since these classes are in the same namespace, they can all "see" each other—even though they're in different files. A class can span multiple files too, but you need to use the "partial" keyword when you declare it.

You can only split a class up into different files if you use the `partial` keyword. You probably won't do that in any of the code you write in this book, but the IDE used it to split your form up into two files, `Form1.cs` and `Form1.Designer.cs`.

Your programs use variables to work with data

When you get right down to it, every program is basically a data cruncher. Sometimes the data is in the form of a document, or an image in a video game, or an instant message. But it's all just data. And that's where **variables** come in. A variable is what your program uses to store data.

Declare your variables

Whenever you **declare** a variable, you tell your program its *type* and its *name*. Once C# knows your variable's type, it'll keep your program from compiling if you make a mistake and try to do something that doesn't make sense, like subtract "Fido" from 48353.

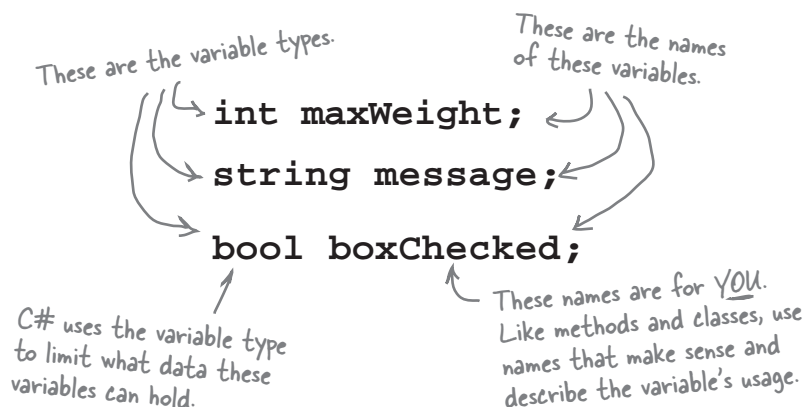

Variables vary

A variable is equal to different values at different times while your program runs. In other words, a variable's value **varies**. (Which is why "variable" is such a good name.) This is really important, because that idea is at the core of every program that you've written or will ever write. So if your program sets the variable `myHeight` equal to 63:

```
int myHeight = 63;
```

any time `myHeight` appears in the code, C# will replace it with its value, 63. Then, later on, if you change its value to 12:

```
myHeight = 12;
```

C# will replace `myHeight` with 12—but the variable is still called `myHeight`.

Whenever your program needs to work with numbers, text, true/false values, or any other kind of data, you'll use variables to keep track of them.

You have to assign values to variables before you use them

Try putting these statements into a C# program:

```
int z;
MessageBox.Show("The answer is " + z);
```

Go ahead, give it a shot. You'll get an error, and the IDE will refuse to compile your code. That's because the IDE checks each variable to make sure that you've assigned it a value before you use it. The easiest way to make sure you don't forget to assign your variables values is to combine the statement that declares a variable with a statement that assigns its value:

```
int maxWeight = 25000;
string message = "Hi!";
bool boxChecked = true;
```

These values are assigned to the variables.

Each declaration has a type, exactly like before.

If you write code that uses a variable that hasn't been assigned a value, your code won't compile. It's easy to avoid that error by combining your variable declaration and assignment into a single statement.

A few useful types

Every variable has a type that tells C# what kind of data it can hold. We'll go into a lot of detail about the many different types in C# in Chapter 4. In the meantime, we'll concentrate on the three most popular types. `int` holds integers (or whole numbers), `string` holds text, and `bool` holds Boolean true/false values.

var-i-a-ble, adjective.
able to be changed or adapted.
*The drill's **variable** speed bit let Bob change the drill speed from slow to fast based on the job he had to do.*

Once you've assigned a value to your variable, that value can change. So there's no disadvantage to assigning a variable an initial value when you declare it.

C# uses familiar math symbols

Once you've got some data stored in a variable, what can you do with it? Well, if it's a number, you'll probably want to add, subtract, multiply, or divide it. And that's where **operators** come in. You already know the basic ones. Let's talk about a few more. Here's a block of code that uses operators to do some simple math:

We declared a new int variable called `number` and set it to 15. Then we added 10 to it. After the second statement, `number` is equal to 25.

```
int number = 15;  
number = number + 10;  
number = 36 * 15;  
number = 12 - (42 / 7);
```

The third statement changes the value of `number`, setting it equal to 36 times 15, which is 540. Then it resets it again, setting it equal to $12 - (42 / 7)$, which is 6.

The `*=` operator is similar to `+=`, except it multiplies the current value of `number` by 3, so it ends up set to 48.

```
number += 10;  
number *= 3;  
number = 71 / 3;
```

This operator is a little different. `+=` means take the value of `number` and add 10 to it. Since `number` is currently equal to 6, adding 10 to it sets its value to 16.

71 divided by 3 is 23.666666. Since `number` is an integer, it can only store whole numbers, so it gets rounded to 23.

This `MessageBox` will pop up a box that says "hello again hello"

```
int count = 0;  
count ++;  
count --;
```

You'll use `int` a lot for counting, and when you do the `++` and `--` operators come in handy. `++` increments count by adding one to the value, and `--` decrements count by subtracting one from it, so it ends up equal to zero.

The `""` is an empty string. It has no characters. (It's kind of like a zero for adding strings.)

```
string result = "hello";  
result += " again " + result;  
MessageBox.Show(result);  
result = "the value is: " + count;  
result = "";
```

When you use the `+` operator with a string, it just puts two strings together. It'll automatically convert numbers to strings for you.

A `bool` stores true or false. The `!` operator means NOT. It flips true to false, and vice versa.

```
bool yesNo = false;  
bool anotherBool = true;  
yesNo = !anotherBool;
```



Don't worry about memorizing these operators now.

You'll get to know them because you'll see 'em over and over again.

Loops perform an action over and over again

Here's a peculiar thing about most large programs: they almost always involve doing certain things over and over again. And that's what **loops** are for—they tell your program to keep executing a certain set of statements as long as some condition is true (or false).

That's a big part of why booleans are so important. A loop uses a test to figure out if it should keep looping.

```
while (x > 5)
```

```
{
    x = x - 3;
}
```

In a while loop, all of the statements inside the curly brackets get executed as long as the condition in the parentheses is true.

Every for loop has three statements. The first sets up the loop. The statement will keep looping as long as the second one is true. And the third statement gets executed after each time through the loop.

```
for (int i = 0; i < 8; i = i + 2)
{
    MessageBox.Show("I'll pop up 4 times");
}
```

Use a code snippet to write simple for loops

You'll be typing for loops in a just a minute, and the IDE can help speed up your coding a little. Type `for` followed by two tabs, and the IDE will automatically insert code for you. If you type a new variable, it'll automatically update the rest of the snippet. Press tab again, and the cursor will jump to the length.

Press tab to get the cursor to jump to the length. The number of times this loop runs is determined by whatever you set length to. You can change length to a number or a variable.

```
for (int i = 0; i < length; i++)
{
}
```

If you change the variable to something else, the snippet automatically changes the other two occurrences of it.

Time to start coding

The real work of any program is in its statements. But statements don't exist in a vacuum. So let's set the stage for digging in and getting some code written. **Create a new Windows Forms Application project.**

This will tell the IDE to create a new project with a blank form and an entry point. You might want to name it something like "Chapter 2 program 1"—you'll be building a whole lot of programs throughout the book.

Build this form

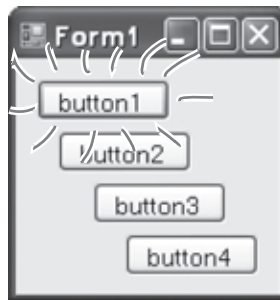

Add statements to show a message

Get started by double-clicking on the first button. Then add these 6 statements to the `button1_Click()` method. Look closely at the code, and the output it produces.

`x` is a variable. The "int" part tells C# that it's an integer, and the rest of the statement sets its value to 3.

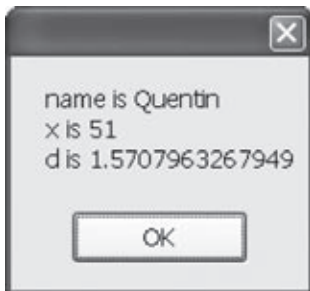

```
private void button1_Click(object sender, EventArgs e)
{
    // this is a comment
    String name = "Quentin";
    int x = 3;
    x = x * 17;
    double d = Math.PI / 2;
    MessageBox.Show("name is " + name
        + "\nx is " + x
        + "\nd is " + d);
}
```

There's a built-in class called `Math`, and it's got a member called `PI`. `Math` lives in the `System` namespace, so the file this code came from needs to have a `using System;` line at the top.

The `\n` is an escape sequence to add a line break to the message box.

Syntax 101

- ★ Each statement must end in a semicolon.

```
x = x + 1;
```

- ★ A single-line comment begins with two forward slashes.

```
// this line is ignored
```

- ★ Most white space doesn't matter.

```
x      =      3  ;
```

is the same as

```
x = 3;
```

- ★ Variables are declared with a **name** and a **type** (there are plenty of types that you'll learn about in chapter 4).

```
int weight;
// weight is an integer
```

- ★ Classes and methods must be defined within a pair of curly braces.

```
public void go() {
    // amazing code here
}
```

if/else statements make decisions

Use **if/else statements** to tell your program to do certain things only when the **conditions** you set up are (or aren't) true. A lot of if/else statements check if two things are equal. That's when you use the `==` operator. That's different from the single equal sign (`=`) operator, which you use to set a value.

```

if (someValue == 24)
{
    MessageBox.Show("The value was 24.");
}

```

Every if statement starts with a conditional test.

The statement inside the curly brackets is executed only if the test is true.

```

if (someValue == 24)
{
    // You can have as many statements
    // as you want inside the brackets
    MessageBox.Show("The value was 24.");
} else {
    MessageBox.Show("The value wasn't 24.");
}

```

Always use two equal signs to check if two things are equal to each other.

if/else statements are pretty straightforward. If the conditional test is true, the program executes the statements between the first set of brackets. Otherwise, it executes the statements between the second set.



Don't confuse the two equal sign operators!

You use one equal sign (`=`) to set a variable's value, but two equal signs (`==`) to compare two variables. You won't believe how many bugs in programs—even ones made by experienced programmers!—were caused by using `=` instead of `==`. If you see the IDE complain that you "cannot implicitly convert type 'int' to 'bool'", that's probably what happened.

Set up conditions and see if they're true

Use **if/else statements** to tell your program to do certain things only when the **conditions** you set up are (or aren't) true.

Use logical operators to check conditions

You've just looked at the `==` operator, which you use to test whether two variables are equal. There are a few other operators, too. Don't worry about memorizing them right now—you'll get to know them over the next few chapters:

- ★ The `!=` operator works a lot like `==` except it's true if the two things you're comparing are **not equal**.
- ★ You can use `>` and `<` to compare numbers and see if one is bigger or smaller than the other.
- ★ The `==`, `!=`, `>`, and `<` are called **conditional operators**. When you use them to test two variables or values, it's called performing a **conditional tests**.
- ★ You can combine individual conditional tests into one long test using the `&&` operator for AND and the `||` operator for OR. So to check if `i` equals 3 or `j` is less than 5, do `(i == 3) || (j < 5)`.

When you use a conditional operator to compare two numbers, it's called a conditional test.

Set a variable and then check its value

Here's the code for the second button. It's an **if/else** statement that checks an integer **variable** called `x` to see if it's equal to 10.

Make sure you stop your program before you do this—the IDE won't let you edit the code while the program's running. You can stop it by closing the window, using the stop button on the toolbar, or selecting "Stop Debugging" from the Debug menu.

```
private void button2_Click(object sender, EventArgs e)
{
    int x = 5;
    if (x == 10)
    {
        MessageBox.Show("x must be 10");
    }
    else
    {
        MessageBox.Show("x isn't 10");
    }
}
```

First we set up a variable called `x` and make it equal to 5. Then we check if it's equal to 10.



Here's the output. See if you can tweak one line of code and get it to say "x must be 10" instead.

Add another conditional test

The third button makes this output. Now make a change to two lines of code so that it pops up both message boxes.

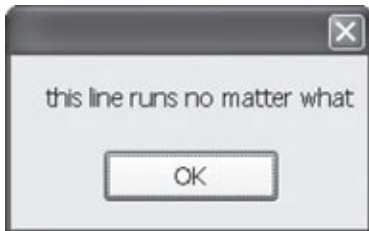

```
private void button3_Click(object sender, EventArgs e)
{
    int someValue = 4;
    String name = "Bobbo Jr.";
    if ((someValue == 3) && (name.Equals("Joe")))
    {
        MessageBox.Show("x is 3 and the name is Joe");
    }
    MessageBox.Show("this line runs no matter what");
}
}
```

This line checks `someValue` to see if it's equal to 3, and then it checks to make sure name is "Joe".

Add loops to your program

Here's the code for the last button. It's got two loops. The first is a **while** loop, which repeats the statements inside the brackets as long as the condition is true—do something *while* this is true. The second one is a **for** loop. Take a look and see how it works.

```
private void button4_Click(object sender, EventArgs e)
{
    int count = 0;
    while (count < 10)
    {
        count = count + 1;
    }
    for (int i = 0; i < 5; i++)
    {
        count = count - 1;
    }
    MessageBox.Show("The answer is " + count);
}
}
```

This loop keeps repeating as long as the count variable is less than 10.

This sets up the loop. It just assigns a value to the integer that'll be used in it.

The second part of the for statement is the test. It says "for as long as i is less than five the loop should keep on going". The test is run before the code block, and the block is executed only if the test is true.

This is where the loop actually does something. In this case, it adds one to i. So every time the loop executes, it will add 1 to i. This is called the iterator, and it's run immediately after all the statements in the code block.

Before you click on the button, read through the code and try to figure out what the message box will show. Then click the button and see if you were right!



Let's get a little more practice with conditional tests and loops. Take a look at the code below. Circle the conditional tests, and fill in the blanks so that the comments correctly describe the code that's being run.

```
int result = 0; // this variable will hold the final result
int x = 6; // declare a variable x and set it to 6
while (x > 3) {
    // execute these statements as long as
    result = result + x; // add x
    x = x - 1; // subtract
}
for (int z = 1; z < 3; z = z + 1) {
    // start the loop by
    // keep looping as long as
    // after each loop,
    result = result + z; //
}
// The next statement will pop up a message box that says
//
MessageBox.Show("The result is " + result);
```

We filled in the first one for you.



More about conditional tests

You can do simple conditional tests by checking the value of a variable using a comparison operator. Here's how you compare two numbers, x and y:

- x < y (less than)
- x > y (greater than)
- x == y (equals—and yes, with two equals signs)

These are the ones you'll use most often.



Wait up! There's a flaw in your logic. What happens to my loop if I write a conditional test that never becomes false?

Then your loop runs forever!

Every time your program runs a conditional test, the result is either **true** or **false**. If it's **true**, then your program goes through the loop one more time. Every loop should have code that, if it's run enough times, should cause the conditional test to eventually return **false**. But if it doesn't then the loop will keep running until you kill the program or turn the computer off!

Sometimes you call this an infinite loop.

Sharpen your pencil



Here are a few loops. Write down if each loop will repeat forever or eventually end. If it's going to end, how many times will it loop?

Loop #1

```
int count = 5;
while (count > 0) {
    count = count * 3;
    count = count * -1;
}
```

Loop #2

```
int i = 0;
while (i == 0) {
    count = count * 3;
    count = count * -1;
}
```

Loop #3

```
int j = 2;
for (int i = 1; i < 100;
     i = i * 2)
{
    j = j - i;
    while (j < 25)
    {
        j = j + 5;
    }
}
```

Loop #4

```
while (true) { int i = 1; }
```

Loop #5

```
int p = 2;
for (int q = 2; q < 32;
     q = q * 2)
{
    while (p < q)
    {
        p = p * 2;
    }
    q = p - q;
}
```

Hint: q starts out equal to zero. Think about when the iterator "q = q * 2" is executed.

Remember, a for loop always runs the conditional test at the beginning of the block, and the iterator at the end of the block.



Can you think of a reason that you'd want to write a loop that never stops running?

Sharpen your pencil Solution

Let's get a little more practice with conditional tests and loops. Take a look at the code below. Circle the conditional tests, and fill in the blanks so that the comments correctly describe the code that's being run.

```

int result = 0; // this variable will hold the final result

int x = 6; // declare a variable x and set it to 6
while (x > 3) {
    // execute these statements as long as x is greater than 3

    result = result + x; // add x to the result variable

    x = x - 1; // subtract 1 from the value of x
}
for (int z = 1; z < 3; z = z + 1) {
    // start the loop by declaring a variable z and setting it to 1
    // keep looping as long as z is less than 3
    // after each loop, add 1 to z
    result = result + z; // add the value of z to result
}
// The next statement will pop up a message box that says
// The result is 18
MessageBox.Show("The result is " + result);
    
```

This loop runs twice—first with z set to 1, and then a second time with z set to 2. Once it hits 3, it's no longer less than 3, so the loop stops.

Sharpen your pencil Solution

Here are a few loops. Write down if each loop will repeat forever or eventually end. If it's going to end, how many times will it loop?

Loop #1
This loop executes once

Loop #3
This loop executes 7 times

Loop #5
This loop executes 8 times.

Loop #2
This loop runs forever

Loop #4
Another infinite loop

After iteration #1, q equals 2. Then it equals 0, then 4, then 0, 8, 0, 16, 0, and the loop stops when it hits 32. Take the time to really figure this one out. It might help to paste the code into the IDE and add messageboxes that pop up the values of p and q.

there are no Dumb Questions

Q: Is every piece of code always in a class?

A: Yes. Any time a C# program does something, it's because statements were executed. Those statements are a part of classes, and those classes are a part of namespaces. Even when it looks like something is not a statement in a class—like when you use the designer to set a property on an object on your form—if you search through your code you'll find that the IDE added or changed statements inside a class somewhere.

Q: Are there any namespaces I'm not allowed to use? Are there any I *have* to use?

A: Yes, there are a few namespaces you're not allowed to use. Notice how all of the `using` lines at the top of your C# class files always said `System`? That's because there's a `System` namespace that's used by the .NET Framework. It's where you find all of your important tools to add power to your programs. Like `System.Data`, which lets you work with tables and databases, and `System.IO`, which lets you work with files and data streams. But for the most part, you can choose any name you want for a namespace (as long as only has letters, numbers and underscores). When you create a new program, the IDE will automatically choose a namespace for you based on the program's name.

Q: I still don't get why I need this partial class stuff.

A: Partial classes are how you can spread the code for one class between more than one file. The IDE does that when it creates a form—it keeps the code you edit in one file (like `Form1.cs`), and the code it modifies automatically for you in another file (`Form1.Designer.cs`). You don't need to do that with a namespace, though. One namespace can span two, three or a dozen or more files. Just put the namespace declaration at the top of the file, and everything within the curly brackets after the declaration is inside the same namespace. One more thing: you can have more than one class in a file. And you can have more than one namespace in a file. You'll learn a lot more about classes in the next few chapters.

Q: Let's say I drag something onto my form, so the IDE generates a bunch of code automatically. What happens to that code if I click "Undo"?

A: The best way to answer this question is to try it! Give it a shot—do something where the IDE generates some code for you.

Drag a button on a form, change properties. Then try to undo it. What happens? Well, for simple things what you'll see is that the IDE is smart enough to undo it itself. But for more complex things, like adding a new SQL database to your project, you'll be given a warning message. It still knows how to undo the action, but it may not be able to redo it.

Q: So exactly how careful do I have to be with the code that's automatically generated by the IDE?

A: You should generally be pretty careful. It's really useful to know what the IDE is doing to your code, and once in a while you'll need to know what's in there in order to solve a serious problem. But in almost all cases, you'll be able to do everything you need to do through the IDE.



BULLET POINTS

- You tell your program to perform actions using statements. Statements are always part of classes, and every class is in a namespace.
- Every statement ends with a semicolon (;)
- When you use the visual tools in the Visual Studio IDE, it automatically adds or changes code in your program.
- Code blocks are surrounded by curly braces { }. Classes, while loops, *if/else* statements and lots of other kinds of statements use those blocks.
- A conditional test is either `true` or `false`. You use conditional tests to determine when a loop ends, and which block of code to execute in an *if/else* statement.
- Any time your program needs to store some data, you use a variable. Use `=` to assign a variable, and `==` to test if two variables are equal.
- A `while` loop runs everything within its block (defined by curly braces) as long as the *conditional test* is `true`.
- If the conditional test is `false`, the `while` loop code block won't run, and execution will move down to the code immediately after the loop block.



Code Magnets

Part of a C# program is all scrambled up on the fridge. Can you rearrange the code snippets to make a working C# program that produces the message box? Some of the curly braces fell on the floor and they were too small to pick up, so feel free to add as many of those as you need!

The "" is an empty string—it means Result has no characters in it yet.

```
string Result = "";
```

This magnet didn't fall off the fridge...

```
MessageBox.Show(Result);
```

```
if (x == 1) {  
    Result = Result + "d";  
    x = x - 1;  
}
```

```
if (x == 2) {  
    Result = Result + "b c";  
}
```

```
if (x > 2) {  
    Result = Result + "a";  
}
```

```
int x = 3;
```

```
x = x - 1;  
Result = Result + "-";
```

```
while (x > 0) {
```

Output:



Answers on page 82.

We'll give you a lot of exercises like this throughout the book. We'll give you the answer in a couple of pages. If you get stuck, don't be afraid to peek at the answer—it's not cheating!

You'll be creating a lot of applications throughout this book, and you'll need to give each one a different name. We recommend naming this one "2 Fun with if-else statements" based on the chapter number and the text in the title bar of the form.



Exercise

Time to get some practice using if/else statements. Can you build this program?

Here's the form.



Add this checkbox.

Drag it out of the toolbox and onto your form. Use the **Text** property to change the text that's next to it. (You also use the **Text** property to change the button and label text.)

This is a label.

You can use the properties to change the font size and make it boldface. Use the **BackColor** property to set to red—choose "Red" from the selection of web colors.

Pop up this message if the user clicks the button but the box IS NOT checked.

If your checkbox is named **checkBox1** (you can change the **Name** property if you want), then here's the conditional test to see if it's checked:

```
checkBox1.Checked == true
```

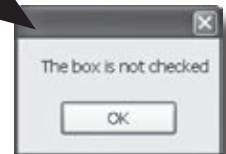

If the user clicks the button and the box IS checked, change the background color of the label.

If the label background color is red, change it to blue when the button is clicked. If it's blue, change it back to red. Here's a statement that sets the background color of a label called **label1**:

```
label1.BackColor = Color.Red;
```

(Hint: The conditional test to check whether a label's background color is red looks a lot like that statement—but with one important difference!)



Let's build something flashy!

Exercise

1 Here's the form to build



Hint: If you declare a variable inside a for loop—`for (int c = 0; ...)`—then that variable's only valid inside the loop's curly brackets. So if you have two for loops that both use the variable, you'll either declare it in each loop or have one declaration outside the loop.

2 Make the form background go all psychedelic!

When the button's clicked, make the form's background color cycle through a whole lot of colors! Create a loop that has a variable `c` go from 0 to 253. Here's the block of code that goes inside the curly brackets:

```
this.BackColor = Color.FromArgb(c, 255 - c, c);
Application.DoEvents();
```

This line tells the program to stop your loop momentarily and do the other things it needs to do, like refresh the form, check for mouse clicks, etc. Try taking out this line and seeing what happens. The form doesn't redraw itself, because it's waiting until the loop is done before it deals with those events.

Later on in the book, you'll learn about a better way to let your programs do more than one thing at a time! But for now, use `Application.DoEvents()` to make sure your form stays responsive while it's in a loop.

Color me impressed!

.NET has a bunch of predefined colors like Blue and Red, but it also lets you make your own colors using the `Color.FromArgb()` method, by specifying three numbers: a red value, a green value, and a blue value.

3 Make it slower

Slow down the flashing by adding this line after the `Application.DoEvents()` line:

```
System.Threading.Thread.Sleep(3);
```

This statement inserts a 3 millisecond delay in the loop. It's a part of the .NET library, and it's in the `System.Threading` namespace.

4 Make it smoother

Let's make the colors cycle back to where they started. Add another loop that has `c` go from 254 down to 0. Use the same block of code inside the curly brackets.

5 Keep it going

Surround your two loops with another loop that continuously executes and doesn't stop, so that when the button is pressed, the background starts changing colors and then keeps doing it. (Hint: The `while (true)` loop will run forever!)

When one loop is inside another one, we call it a "nested" loop.

Uh-oh! The program doesn't stop!

Run your program in the IDE. Start it looping. Now close the window. Wait a minute—the IDE didn't go back into edit mode! It's acting like the program is still running. You need to actually stop the program using the square stop button in the IDE (or select "Stop Debugging" from the Debug menu).

6 Make it stop

Make the loop you added in step #5 stop when the program is closed. Change your outer loop to this:

```
while (Visible)
```

Now run the program and click the X box in the corner. The window closes, and then the program stops! Except... there's a delay of a few seconds before the IDE goes back to edit mode.

When you're checking a boolean value like `Visible` in an if statement or a loop, sometimes it's tempting to test for `(visible == true)`. You can leave off the `"== true"`—it's enough to include the boolean.

When you're working with a form or control, `Visible` is true as long as the form or control is being displayed. If you set it to false, it makes the form or control disappear.

Hint: The `&&` operator means "AND". It's how you string a bunch of conditional tests together into one big test that's true only if the first test is true AND the second is true AND the third, etc. And it'll come in handy to solve this problem.

Can you figure out what's causing that delay? Can you fix it so the program ends immediately when you close the window?



Exercise Solution

Time to get some practice using if/else statements. Can you build this program?

Here's the entire Form1.cs file for the "Fun with If/Else Statements!" exercise. If we show you a lot of code in a file like this, we'll draw a grey box behind the part that you should add.

```
using System;
using System.Collections.Generic;
using System.ComponentModel;
using System.Data;
using System.Drawing;
using System.Linq;
using System.Text;
using System.Windows.Forms;

namespace Fun_with_If_Else
{
    public partial class Form1 : Form
    {
        public Form1()
        {
            InitializeComponent();
        }

        private void button1_Click(object sender, EventArgs e)
        {
            if (checkBox1.Checked == true)
            {
                if (label1.BackColor == Color.Red)
                {
                    label1.BackColor = Color.Blue;
                }
                else
                {
                    label1.BackColor = Color.Red;
                }
            }
            else
            {
                MessageBox.Show("The box is not checked");
            }
        }
    }
}
```

Here's the code for the form. We named our solution "Fun with If Else", so the IDE made the namespace Fun_with_If_Else. If you gave your solution a different name, it'll have a different namespace.

The IDE added the method called button1_Click() to your form when you double-clicked on the button. The method gets run every time the button's clicked.

The outer if statement checks the checkbox to see if it's been checked. Check!

The inner if statement checks the label's color. If the label is currently red, it executes a statement to turn it blue.

This statement's run if the label's background color is not red to make it set back to red.

This MessageBox pops up if the checkbox isn't checked.

You can download the code for all of the exercise solutions in this book from www.headfirstlabs.com/books/hfcsharp/



Exercise Solution

Let's build something flashy!

Sometimes we won't show you the entire code in the solution, just the bits that changed. All of the logic in the FlashyThing project is in this `button1_Click()` method that the IDE added when you double-clicked the button in the form designer.

When the IDE added this method, it added an extra return before the curly bracket. Sometimes we'll put the bracket on the same line like this to save space—but C# doesn't care about extra space, so this is perfectly valid.

```
private void button1_Click(object sender, EventArgs e) {
```

```
    while (Visible) {
```

The outer loop keeps running as long as the form is visible. As soon as it's closed, `Visible` is false, and the while will stop looping.

```
        for (int c = 0; c < 254 && Visible; c++) {
```

```
            this.BackColor = Color.FromArgb(c, 255 - c, c);
```

```
            Application.DoEvents();
```

```
            System.Threading.Thread.Sleep(3);
```

The first for loop makes the colors cycle one way, and the second for loop reverses them so they look smooth.

```
        }
```

We used "`Visible`" instead of "`Visible == true`". It's just like saying "if it's visible" instead of "if it's true that it's visible"—they mean the same thing.

```
        for (int c = 254; c >= 0 && Visible; c--) {
```

```
            this.BackColor = Color.FromArgb(c, 255 - c, c);
```

```
            Application.DoEvents();
```

```
            System.Threading.Thread.Sleep(3);
```

We fixed the extra delay by using the `&&` operator to make each of the for loops also check `Visible`. That way the loop ends as soon as `Visible` turns false.

```
        }
```

Can you figure out what's causing that delay? Can you fix it so the program ends immediately when you close the window?

The delay happens because the for loops need to finish before the while loop can check if `Visible` is still true. You can fix it by adding `&& Visible` to the conditional test in each for loop.

```
    }
```

Was your code a little different than ours? There's more than one way to solve any programming problem—like you could have used while loops instead of for loops. If your program works, then you got the exercise right!

this puzzle's tougher than it looks

Pool Puzzle



Your **job** is to take code snippets from the pool and place them into the blank lines in the code. You may **not** use the same snippet more than once, and you won't need to use all the snippets. Your **goal** is to make a class that will compile and run. Don't be fooled—this one's harder than it looks.

Output

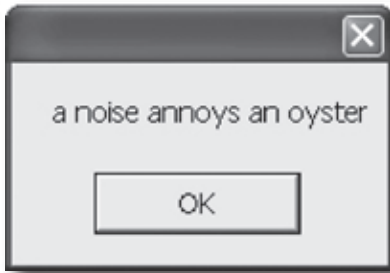

We included these "Pool Puzzle" exercises throughout the book to give your brain an extra-tough workout. If you're the kind of person who loves twisty little logic puzzles, then you'll love this one. If you're not, give it a shot anyway—but don't be afraid to look at the answer to figure out what's going on. And if you're stumped by a pool puzzle, definitely move on.

Note: each snippet from the pool can only be used once!

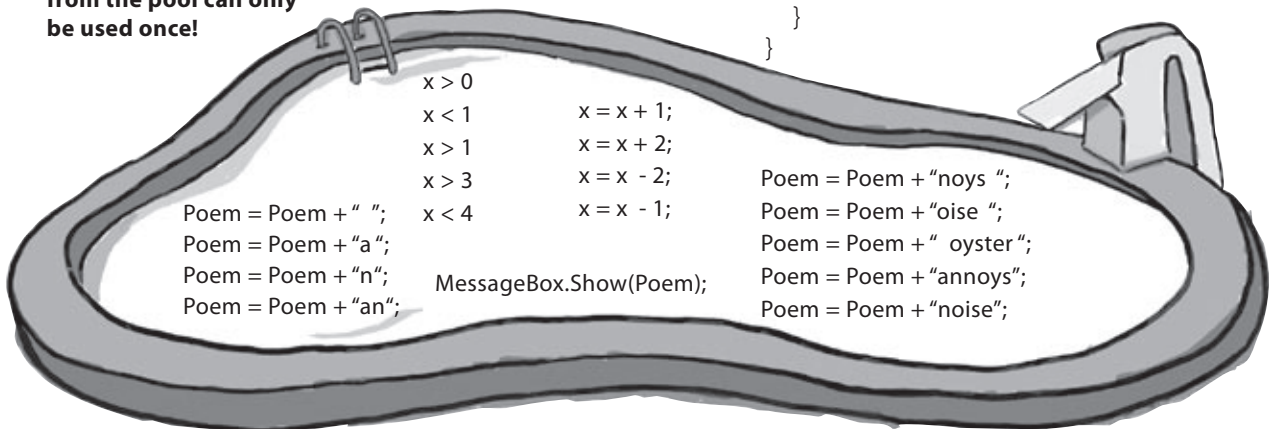

	x > 0		
	x < 1	x = x + 1;	
	x > 1	x = x + 2;	
	x > 3	x = x - 2;	
Poem = Poem + " ";	x < 4	x = x - 1;	Poem = Poem + "noys ";
Poem = Poem + "a";			Poem = Poem + "oise ";
Poem = Poem + "n";			Poem = Poem + " oyster";
Poem = Poem + "an";	MessageBox.Show(Poem);		Poem = Poem + "annoys";
			Poem = Poem + "noise";

```
using System;
using System.Windows.Forms;
namespace Chapter_2 {
    class Chapter2PoolPuzzle {
        public static void Main() {
            int x = 0;
            String Poem = "";

            while ( _____ ) {

                _____
                if ( x < 1 ) {
                    _____
                }
                _____

                if ( _____ ) {
                    _____
                }
                if ( x == 1 ) {
                    _____
                }
                if ( _____ ) {
                    _____
                }
            }
        }
    }
}
```



Csharpcross

How does a crossword help you learn C#? Well, all the words are C#-related and from this chapter. The clues also provide mental twists and turns that will help you burn alternative routes to C# right into your brain

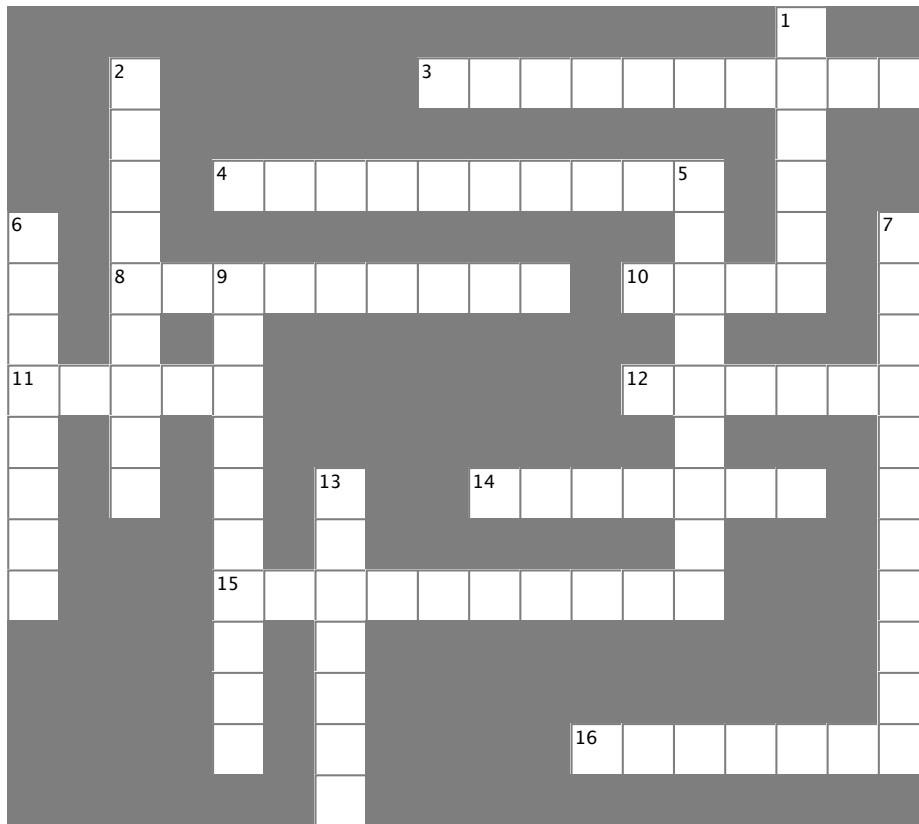

Across

3. You give information to a method using these
4. `button1.Text` and `checkBox3.Name` are examples of
8. Every statement ends with one of these
10. The name of every C# program's entry point
11. Contains methods
12. Your statements live here
14. A kind of variable that's either true or false
15. A special method that tells your program where to start
16. This kind of class spans multiple files

Down

1. The output of a method is its _____ value
2. `System.Windows.Forms` is an example of one of these
5. A tiny piece of a program that does something
6. A block of code is surrounded by
7. The kind of test that tells a loop when to end
9. You can call _____.`Show()` to pop up a simple Windows dialog box
13. The kind of variable that contains a whole number



Code Magnets Solution

Part of a C# program is all scrambled up on the fridge. Can you rearrange the code snippets to make a working C# program that produces the message box? Some of the curly braces fell on the floor and they were too small to pick up, so feel free to add as many of those as you need!

```
string Result = "";
```

This magnet didn't fall off the fridge...

```
int x = 3;
```

```
while (x > 0) {
```

```
{
```

```
if (x > 2) {
    Result = Result + "a";
}
```

```
x = x - 1;
Result = Result + "-";
```

```
if (x == 2) {
    Result = Result + "b c";
}
```

```
if (x == 1) {
    Result = Result + "d";
    x = x - 1;
}
```

```
}
```

```
MessageBox.Show(Result);
```

The first time through the loop, x is equal to 3 so this conditional test will be true.

This statement makes x equal to 2 the first time through the loop, and 1 the second time through.

Output:





Pool Puzzle Solution

Your **job** was to take code snippets from the pool and place them into the blank lines in the code. Your **goal** was to make a class that will compile and run.

```
using System;
using System.Windows.Forms;
namespace Chapter_2 {
    class Chapter2PoolPuzzle {
        public static void Main() {
            int x = 0;
            String Poem = "";

            while ( x < 4 ) {

                Poem = Poem + "a";
                if ( x < 1 ) {
                    Poem = Poem + " ";
                }
                Poem = Poem + "n";

                if ( x > 1 ) {

                    Poem = Poem + " oyster";

                    x = x + 2;
                }
                if ( x == 1 ) {

                    Poem = Poem + "noys ";
                }
                if ( x < 1 ) {

                    Poem = Poem + "oise ";
                }

                x = x + 1;
            }
            MessageBox.Show(Poem);
        }
    }
}
```

Did you get a different solution? Type it into the IDE and see if it works! There's more than one correction solution to the pool puzzle.



If you want a real challenge, see if you can figure out what it is! Here's a hint: There's another solution that keeps the word fragments in order.

3 objects: get oriented!



Making Code Make Sense



... and that's why my Husband class doesn't have a `HelpOutAroundTheHouse()` method or a `PullHisOwnWeight()` method.



Every program you write solves a problem.

When you're building a program, it's always a good idea to start by thinking about what *problem* your program's supposed to solve. That's why **objects** are really useful. They let you structure your code based on the problem it's solving, so that you can spend your time *thinking about the problem* you need to work on rather than getting bogged down in the mechanics of writing code. When you use objects right, you end up with code that's *intuitive* to write, and easy to read and change.

How Mike thinks about his problems

Mike's a programmer about to head out to a job interview. He can't wait to show off his C# skills, but first he has to get there—and he's running late!

- 1 Mike figures out the route he'll take to get to the interview.



I'll take the 31st Street bridge, head up Liberty Avenue, and go through Bloomfield.

Mike sets his destination, then comes up with a route.

- 2 Good thing he had his radio on. There's a huge traffic jam that'll make him late!

Mike gets new information about a street he needs to avoid.



This is Frank Loudly with your eye-in-the-sky shadow traffic report. It looks like a three-car pileup on Liberty has traffic backed up all the way to 32nd Street.

- 3 Mike comes up with a new route to get to his interview on time.

Now he can come up with a new route to the interview.

No problem. If I take Route 28 instead, I'll still be on time!



How Mike's car navigation system thinks about his problems

Mike built his own GPS navigation system, which he uses to help him get around town.

Here's a diagram of a class in Mike's program. It shows the name on top, and the methods on the bottom.

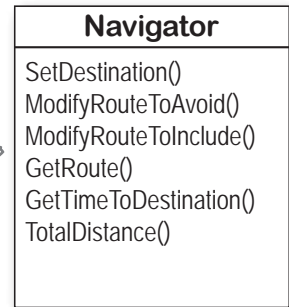

```
SetDestination("Fifth Ave & Penn Ave");
string route;
route = GetRoute();
```

The navigation system sets a destination and comes up with a route

Here's the output from the GetRoute() method—it's a string that contains the directions Mike should follow.

"Take 31st Street Bridge to Liberty Avenue to Bloomfield"

The navigation system gets new information about a street it needs to avoid.

```
ModifyRouteToAvoid("Liberty Ave");
```

Now it can come up with a new route to the destination.

```
string route;
route = GetRoute();
```

"Take Route 28 to the Highland Park Bridge to Washington Blvd"

GetRoute() gives a new route that doesn't include the street Mike wants to avoid.



Mike's navigation system solves the street navigation problem the same way he does

Mike's Navigator class has methods to set and modify routes

Mike's Navigator class has methods, which are where the action happens. But unlike the `button_Click()` methods in the forms you've built, they're all focused around a single problem: navigating a route through a city. That's why Mike stuck them together into one class, and called that class `Navigator`.

Mike designed his `Navigator` class so that it's easy to create and modify routes. To get a route, Mike's program calls the `SetDestination()` method to set the destination, and then uses the `GetRoute()` method to put the route into a string. If he needs to change the route, his program calls the `ModifyRouteToAvoid()` method to change the route so that it avoids a certain street, and then calls the `GetRoute()` method to get the new directions.

Mike chose method names that would make sense to someone who was thinking about how to navigate a route through a city.

```
public class Navigator() {  
    public void SetDestination(string destinationName) { ... };  
    public void ModifyRouteToAvoid(string streetName) { ... };  
    public string GetRoute() { ... };  
}
```

This is the return type of the method. It means that the statement calling the `GetRoute()` method can use it to set a string variable that will contain the directions. When it's void, that means the method doesn't return anything.

```
string route;  
route = GetRoute();
```

Some methods have a return value

Every method is made up of statements that do things. Some methods just execute their statements and then exit. But other methods have a **return value**, or a value that's calculated or generated inside the method, and sent back to the statement that called that method. The type of the return value (like `string` or `int`) is called the **return type**.

The **return** statement tells the method to immediately exit. If your method doesn't have a return value—which means it's declared with a return type of **void**—then the **return** statement just ends with a semicolon, and you don't always have to have one in your method. But if the method has a return type, then it must use the **return** statement.

Here's an example of a method that has a return type—it returns an `int`. The method uses the two parameters to calculate the result and uses the **return** statement to pass the value back to the statement that called it.

```
public int MultiplyTwoNumbers(int firstNumber, int secondNumber) {  
    int result = firstNumber * secondNumber;  
    return result;  
}
```

Here's a statement that calls a method to multiply two numbers. It returns an `int`:

```
int myResult = MultiplyTwoNumbers(3, 5);
```

Methods can take values like 3 and 5. But you can also pass variables to them.

Use what you've learned to build a simple application

Let's hook up a form to a class, and make its button call a method inside that class.



- 1 Create a new Windows Application project in the IDE. Then add a class file to it called `Talker.cs` by right-clicking on the project in the Solution Explorer and selecting "Class..." from the Add menu. When you name your new class file "Talker.cs", the IDE will automatically name the class in the new file `Talker`. Then it'll pop up the new file in a new tab inside the IDE.
- 2 Add `using System.Windows.Forms;` to the top of the class file. Then add code to the class:

```
class Talker {
    public static int BlahBlahBlah(string thingToSay, int numberOfTimes) {
        string finalString = "";
        for (int count = 1; count <= numberOfTimes; count++) {
            finalString = finalString + thingToSay + "\n";
        }
        MessageBox.Show(finalString);
        return finalString.Length;
    }
}
```

This statement declares a `finalString` variable and sets it equal to an empty string.

This line of code adds the contents of `thingToSay` and a linebreak onto the end of it to the `finalString` variable.

This is called a property—every string has a property called `Length`. When it calculates the length of a string, `\n` counts as one character.

The `BlahBlahBlah()` method's return value is an integer that has the total length of the message it displayed. You can add "`Length`" to any string to figure out how long it is.

The new class has one method called `BlahBlahBlah()` that takes two parameters. The first parameter is a string that tells it something to say, and the second is the number of times to say it. When it's called, it pops up a `MessageBox` with the message repeated a number of times. Its return value is the length of the string. The method needs a string for its `thingToSay` parameter and a number for its `numberOfTimes` parameter. It'll get those parameters from a form that lets the user enter text using a **TextBox** control and a number using **NumericUpDown** control.

- 3 Add this form to your project.

Then double-click on the button and have it run this code that calls `BlahBlahBlah()` and assigns its return value to an integer called `len`:

```
int len = Talker.BlahBlahBlah(textBox1.Text, (int) numericUpDown1.Value);
MessageBox.Show("The message length is " + len);
```

Set the default text of the `TextBox` to "Hello!" using its `Text` property.

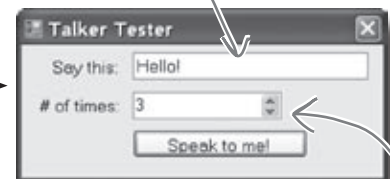

- 4 Now run your program! Click the button and watch it pop up two message boxes. The class pops up the first message box, and the form pops up the second one.

The `BlahBlahBlah()` method pops up this message box based on what's in its parameters.

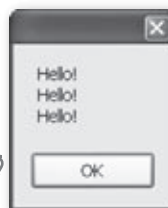

When the method returns a value, the form pops it up in this message box.

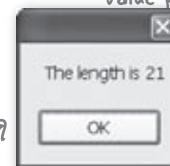

This is a `NumericUpDown` control. Set its `Minimum` property to 1, its `Maximum` property to 10, and its `Value` property to 3.

you are here ▶

Mike gets an idea

The interview went great! But the traffic jam this morning got Mike thinking about how he could improve his navigator.



It'd be great if I could compare a few routes and figure out which is fastest...

He could create three different Navigator classes...

Mike could copy the Navigator class code and paste it into two more classes. Then his program could store three routes at once.

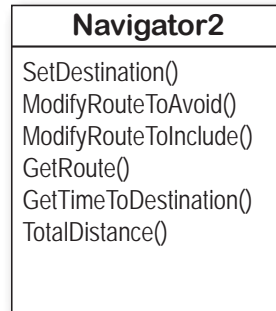
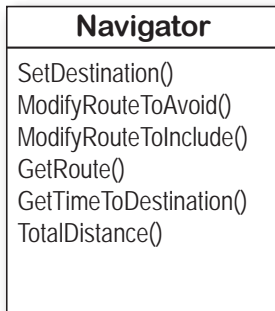

This box is a **class diagram**. It lists all of the methods in a class, and it's an easy way to see everything that it does at a glance.

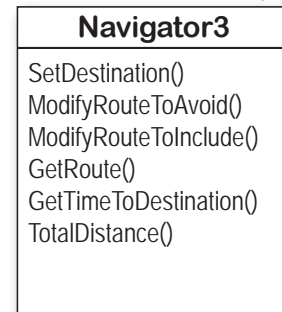

Whoa, that can't be right!
What if I want to change a method? Then I need to go back and fix it in three places.



Right! Maintaining three copies of the same code is really messy. A lot of problems you need to solve need a way to represent one **thing** a bunch of different times. In this case, it's a bunch of routes. But it could be a bunch of turbines, or dogs, or music files, or anything. All of those programs have one thing in common: they always need to treat the same kind of thing in the same way, no matter how many of the thing they're dealing with.

Mike can use objects to solve his problem

Objects are C#'s tool that you use to work with a bunch of similar things. Mike can use objects to program his Navigator class just once, but use it *as many times as he wants* in a program.

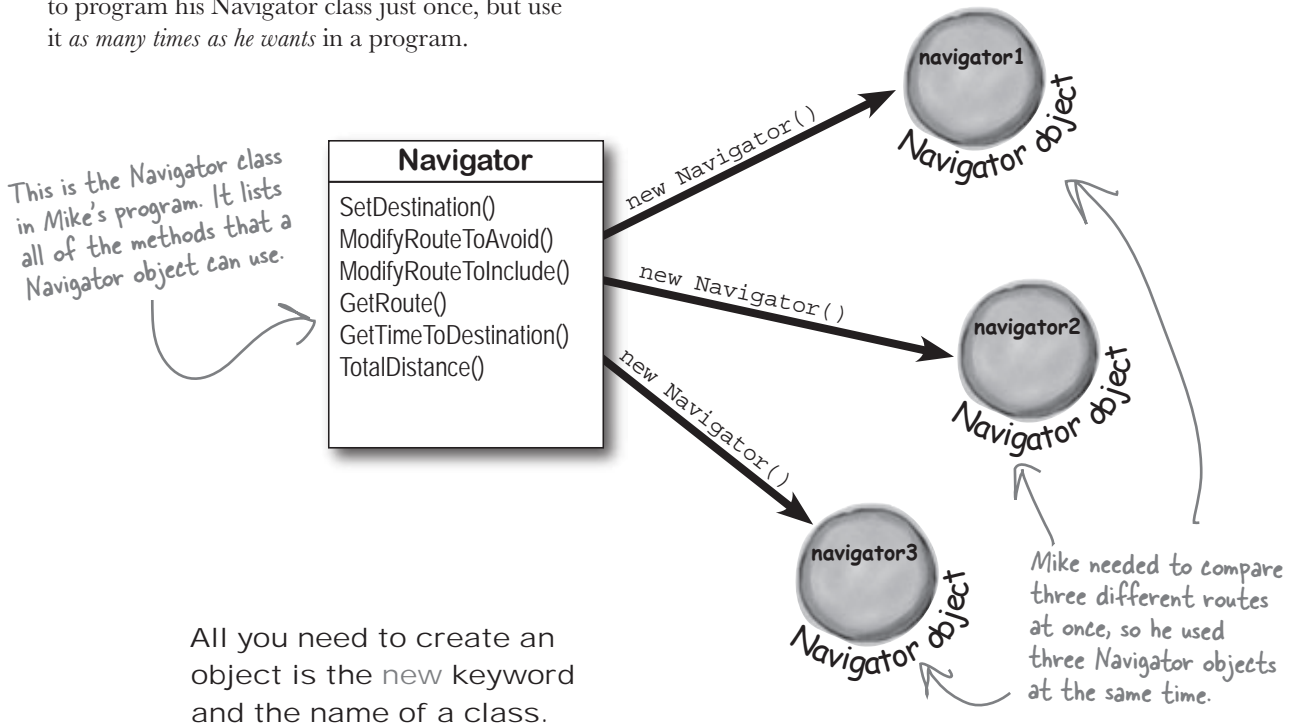

```
Navigator navigator1 = new Navigator();
navigator1.SetDestination("Fifth Ave & Penn Ave");
string route;
route = navigator1.GetRoute();
```

Now you can use the object! When you create an object from a class, that object has all of the methods from that class.

for instance...

You use a class to build an object

A class is like a blueprint for an object. If you wanted to build five identical houses in a suburban housing development, you wouldn't ask an architect to draw up five identical sets of blueprints. You'd just use one blueprint to build five houses.

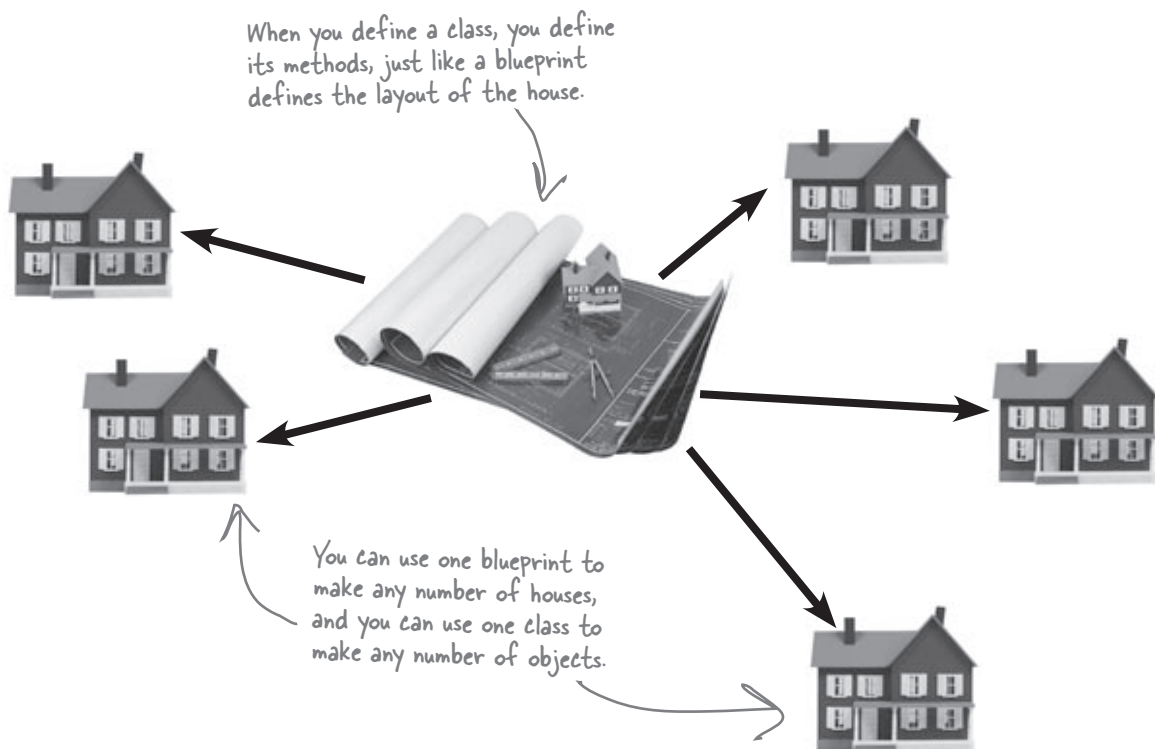

An object gets its methods from its class

Once you build a class, you can create as many objects as you want from it using the new statement. When you do, every public method in your class becomes part of the object.

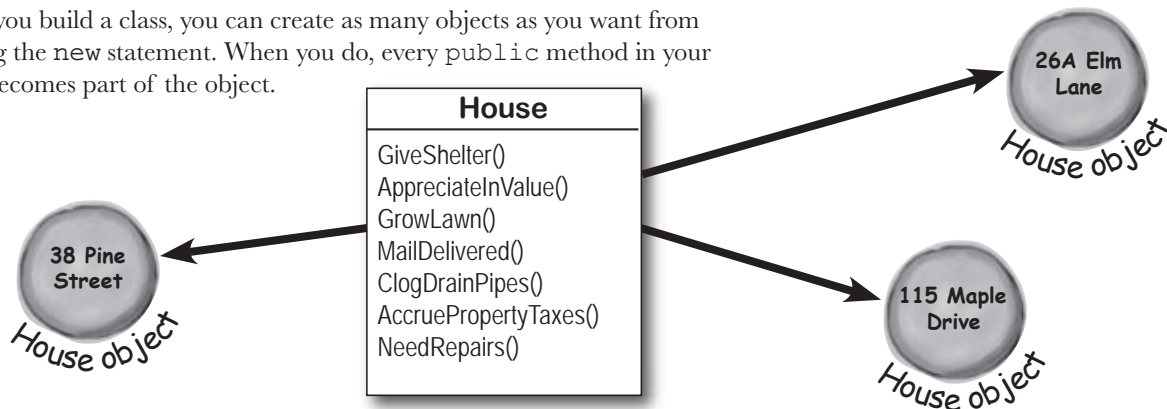

When you create a new object from a class, it's called an instance of that class.

Guess what... you already know this stuff! Everything in the toolbox is a class: there's a `Button` class, a `TextBox` class, a `Label` class, etc. When you drag a button out of the toolbox, the IDE automatically creates an instance of the `Button` class and calls it `button1`. When you drag another button out of the toolbox, it creates another instance called `button2`. Each instance of `Button` has its own properties and methods. But every button acts exactly the same way, because they're all instances of the same class.

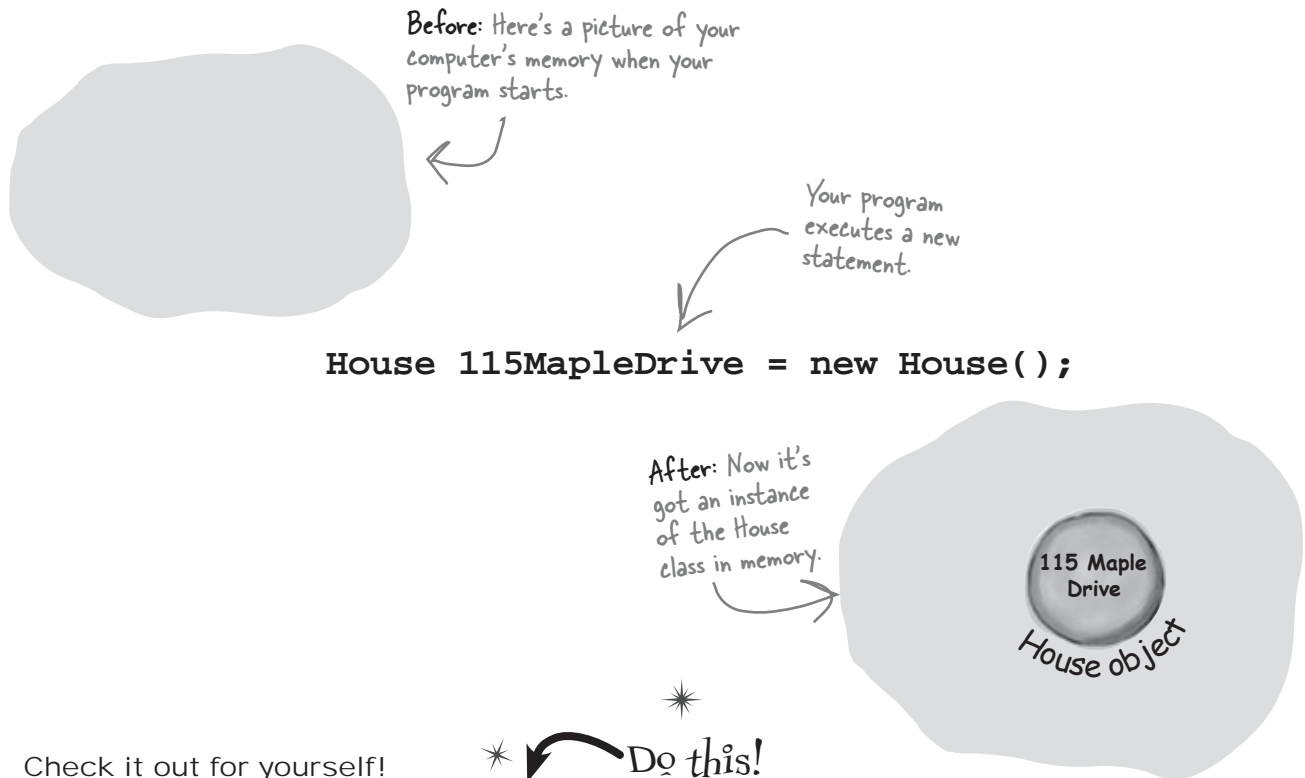

Check it out for yourself!

Open any project that uses a button called `button1`, and use the IDE to search the entire project for the text "`button1 = new`". You'll find the code that the IDE added to the form designer to create the instance of the `Button` class.

in-stance, noun.
an example or one occurrence of something. *The IDE search-and-replace feature finds every **instance** of a word and changes it to another.*

A better solution... brought to you by objects!

GUI stands for Graphical User Interface, which is what you're building when you make a form in the form designer.

Mike came up with a new route comparison program that uses objects to find the shortest of three different routes to the same destination. Here's how he built his program.

- 1 Mike set up a GUI with a text box—`textBox1` contains the **destination** for the three routes. Then he added `textBox2`, which has a street that one of the routes should **avoid**; and `textBox3`, which contains a different street that the third route has to **include**.
- 2 He created a Navigator object and set its destination.

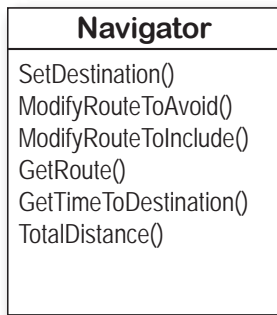

```
String destination = textBox1.Text;
Navigator navigator1 = new Navigator();
navigator1.SetDestination(destination);
route = navigator1.GetRoute();
```

- 3 Then he added a second Navigator object called `navigator2`. He called its `SetDestination()` method to set the destination, and then he called its `ModifyRouteToAvoid()` method.
- 4 The third Navigator object is called `navigator3`. Mike set its destination, and then called its `ModifyRouteToInclude()` method.

The `SetDestination()`, `ModifyRouteToAvoid()` and `ModifyRouteToInclude()` methods all take a string as a parameter.



- 5 Now Mike can call each object's `TotalDistance()` method to figure out which route is the shortest. And he only had to write the code once, not three times!

Any time you create a new object from a class, it's called creating an instance of that class.



Follow the same steps that Mike followed on the facing page to write the code to create Navigator objects and call their methods.

```
String destination = textBox1.Text;
String route2StreetToAvoid = textBox2.Text;
String route3StreetToInclude = textBox3.Text;
```

We gave you a head start. Here's the code Mike wrote to get the destination and street names from the textboxes.

```
Navigator navigator1 = new Navigator();
navigator1.SetDestination(destination);
int distance1 = navigator1.TotalDistance();
```

And here's the code to create the navigator object, set its destination, and get the distance.

1. Create the **navigator2** object, set its destination, call its **ModifyRouteToAvoid()** method, and use its **TotalDistance()** method to set an integer variable called **distance2**.

Navigator navigator2 =

navigator2......

navigator2......

int distance2 =

2. Create the **navigator3** object, set its destination, call its **ModifyRouteToInclude()** method, and use its **TotalDistance()** method to set an integer variable called **distance3**.

.....

.....

.....

.....

The built-in C# `Math.Min()` method compares two numbers and returns the smallest one. Mike used it to find the shortest distance to the destination.

```
int shortestDistance = Math.Min(distance1, Math.Min(distance2, distance3));
```



Sharpen your pencil Solution

Follow the same steps that Mike followed on the facing page to write the code to create Navigator objects and call their methods.

```
String destination = textBox1.Text;
String route2StreetToAvoid = textBox2.Text;
String route3StreetToInclude = textBox3.Text;

Navigator navigator1 = new Navigator();
navigator1.SetDestination(destination);
int distance1 = navigator1.TotalDistance();
```

We gave you a head start. Here's the code to get the destination and street names, along with the code to create the first Navigator object, set its route, and get the distance.

1. Create the **navigator2** object, set its destination, call its **ModifyRouteToAvoid()** method, and use its **TotalDistance()** method to set an integer variable called **distance2**.

```
Navigator navigator2 = new Navigator()
```

```
navigator2.SetDestination(destination);
```

```
navigator2.ModifyRouteToAvoid(route2StreetToAvoid);
```

```
int distance2 = navigator2.TotalDistance();
```

2. Create the **navigator3** object, set its destination, call its **ModifyRouteToInclude()** method, and use its **TotalDistance()** method to set an integer variable called **distance3**.

```
Navigator navigator3 = new Navigator()
```

```
navigator3.SetDestination(destination);
```

```
navigator3.ModifyRouteToInclude(route3StreetToInclude);
```

```
int distance3 = navigator3.TotalDistance();
```

The built-in C# `Math.Min()` method compares two numbers and returns the smallest one. Mike used it to find the shortest distance to the destination.

```
int shortestDistance = Math.Min(distance1, Math.Min(distance2, distance3));
```

Hold it! I've written a few classes now, but I haven't used "new" to create an instance yet! So does that mean I can call methods without creating objects?



Yes! That's why you used the **static** keyword in your methods.

Take another look at the declaration for the `Talker` class you built a few pages ago:

```
class Talker
{
    public static int BlahBlahBlah(String thingToSay, int numberOfTimes)
    {
        string finalString = "";
    }
}
```

When you called the method you didn't create a new instance of `Talker`. You just did this:

```
Talker.BlahBlahBlah("Hello hello hello", 5);
```

That's how you call **static** methods, and you've been doing that all along. If you take away the **static** keyword from the `BlahBlahBlah()` method declaration, then you'll have to create an instance of `Talker` in order to call the method. Other than that distinction, static methods are just like object methods. You can pass parameters, they can return values, and they live in classes.

There's one more thing you can do with the **static** keyword. You can mark your **whole class** as static, and then all of its methods **must** be **static** too. If you try to add a non-static method to a static class, it won't compile.

there are no Dumb Questions

Q: When I think of something that's "static", I think of something that doesn't change. Does that mean non-static methods can change, but static methods don't? Do they behave differently?

A: No, both static and non-static methods act exactly the same. The only difference is that static methods don't require an instance, while non-static methods do. A lot of people have trouble remembering that, because the word "static" isn't really all that intuitive.

Q: So I can't use my class until I create an instance of an object?

A: You can use its static methods. But if you have methods that aren't static, then you need an instance before you can use them.

Q: Then why would I want a method that needs an instance? Why wouldn't I make all my methods static?

A: Because if you have an object that's keeping track of certain data—like Mike's instances of his `Navigator` class that each kept track of a different route—then you can use each instance's methods to work with that data. So when Mike called his `ModifyRouteToAvoid()` method in the `navigator2` instance, it only affected the route that was stored in that particular instance. It didn't affect the `navigator1` or `navigator3` objects. That's how he was able to work with three different routes at the same time—and his program could keep track of all of it.

Q: So how does an instance keep track of data?

A: Turn the page and find out!

An instance uses fields to keep track of things

You change the text on a button by setting its Text property in the IDE. When you do, the IDE adds code like this to the designer:

```
button1.Text = "Text for the button";
```

Now you know that `button1` is an instance of the `Button` class. What that code does is modify a **field** for the `button1` instance. You can add fields to a class diagram—just draw a horizontal line in the middle of it. Fields go above the line, methods go underneath it.

Technically, it's setting a property. A property is very similar to a field—but we'll get into all that a little later on.

This is where a class diagram shows the fields. Every instance of the class uses them to keep track of its state.

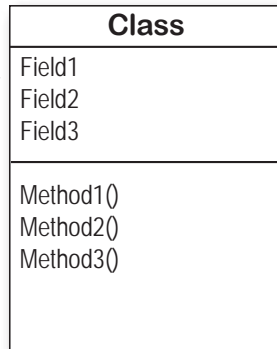

Add this line to separate the fields from the methods.

Methods are what an object does. Fields are what the object knows.

When Mike created three instances of `Navigator` classes, his program created three objects. Each of those objects was used to keep track of a different route. When the program created the `navigator2` instance and called its `SetDestination()` method, it set the destination for that one instance. But it didn't affect the `navigator1` instance or the `navigator3` instance.

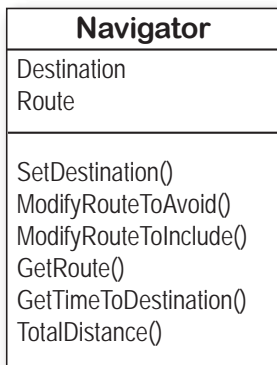

Every instance of `Navigator` knows its destination and its route.

What a `Navigator` object does is let you set a destination, modify its route, and get information about that route.

An object's behavior is defined by its methods, and it uses fields to keep track of its state.

Let's create some instances!

It's easy to add fields to your class. Just declare variables outside of any methods. Now every instance gets its own copy of those variables.

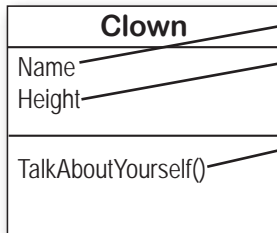

```
public class Clown {
    public String Name;
    public int Height;

    public void TalkAboutYourself() {
        MessageBox.Show("My name is "
            + Name + " and I'm "
            + Height + " inches tall.");
    }
}
```

Remember, when you see "void" in front of a method, it means that it doesn't return any value.

When you want to create instances of your class, don't use the static keyword in either the class declaration or the method declaration.

Remember, the *= operator tells C# to take whatever's on the left of the operator and multiply it by whatever's on the right.

Sharpen your pencil

Write down the contents of each message box that will be displayed after the statement next to it is executed.

```
Clown oneClown = new Clown();
oneClown.Name = "Boffo";
oneClown.Height = 14;
```

```
oneClown.TalkAboutYourself();
```

"My name is _____ and I'm _____ inches tall."

```
Clown anotherClown = new Clown();
anotherClown.Name = "Biff";
anotherClown.Height = 16;
```

```
anotherClown.TalkAboutYourself();
```

"My name is _____ and I'm _____ inches tall."

```
Clown clown3 = new Clown();
clown3.Name = anotherClown.Name;
clown3.Height = oneClown.Height - 3;
```

```
clown3.TalkAboutYourself();
```

"My name is _____ and I'm _____ inches tall."

```
anotherClown.Height *= 2;
```

```
anotherClown.TalkAboutYourself();
```

"My name is _____ and I'm _____ inches tall."

Thanks for the memory

When your program creates an object, it lives in a part of the computer's memory called the **heap**. When your code creates an object with a new statement, C# immediately reserves space in the heap so it can store the data for that object.

Here's a picture of the heap before the project starts. Notice that it's empty.



Let's take a closer look at what happened here

Sharpen your pencil Solution

```
Clown oneClown = new Clown();  
oneClown.Name = "Boffo";  
oneClown.Height = 14;  
oneClown.TalkAboutYourself();  
  
Clown anotherClown = new Clown();  
anotherClown.Name = "Biff";  
anotherClown.Height = 16;  
anotherClown.TalkAboutYourself();  
  
Clown clown3 = new Clown();  
clown3.Name = anotherClown.Name;  
clown3.Height = oneClown.Height - 3;  
clown3.TalkAboutYourself();  
  
anotherClown.Height *= 2;  
anotherClown.TalkAboutYourself();
```

Write down the contents of each message box that will be displayed after the statement next to it is executed.

Each of these **new** statements creates an instance of the **Clown** class by reserving a chunk of memory on the heap for that object and filling it up with the object's data.

"My name is Boffo and I'm 14 inches tall."

"My name is Biff and I'm 16 inches tall."

"My name is Biff and I'm 11 inches tall."

"My name is Biff and I'm 32 inches tall."

When your program creates a new object, it gets added to the heap.

What's on your program's mind

Here's how your program creates a new instance of the Clown class:

```
Clown myInstance = new Clown();
```

That's actually two statements combined into one. The first statement declares a variable of type Clown (`Clown myInstance;`). The second statement creates a new object and assigns it to the variable that was just created (`myInstance = new Clown();`). Here's what the heap looks like after each of these statements:

1 `Clown oneClown = new Clown();`
`oneClown.Name = "Boffo";`
`oneClown.Height = 14;`
`oneClown.TalkAboutYourself();`

The first object is created, and its fields are set.

2 `Clown anotherClown = new Clown();`
`anotherClown.Name = "Biff";`
`anotherClown.Height = 16;`
`anotherClown.TalkAboutYourself();`

These statements create the second object and fill it with data.

3 `Clown clown3 = new Clown();`
`clown3.Name = anotherClown.Name;`
`clown3.Height = oneClown.Height - 3;`
`clown3.TalkAboutYourself();`

Then the third Clown object is created and populated.

4 `anotherClown.Height *= 2;`
`anotherClown.TalkAboutYourself();`

There's no new command, which means these statements don't create a new object. They're just modifying one that's already in memory.

This object is an instance of the Clown class.

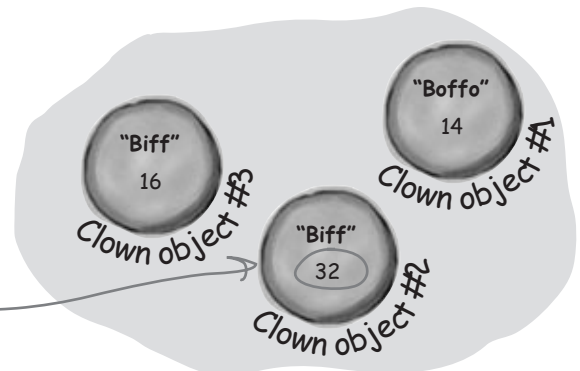
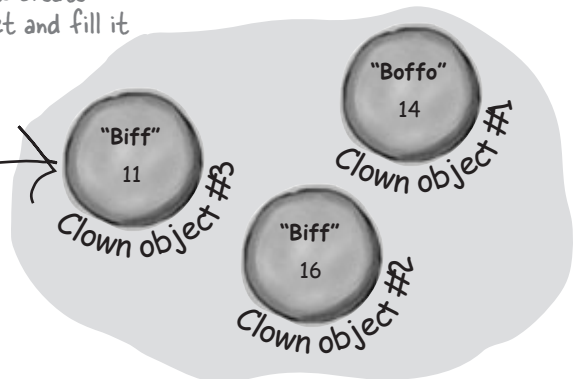
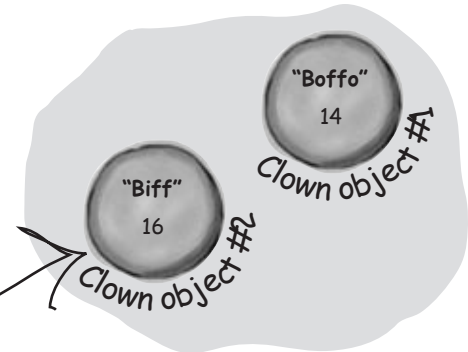
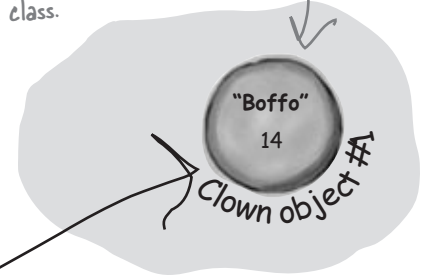

You can use class and method names to make your code intuitive

When you put code in a method, you're making a choice about how to structure your program. Do you use one method? Do you split it into more than one? Or do you even need a method at all? The choices you make about methods can make your code much more intuitive—or, if you're not careful, much more convoluted.

- 1** Here's a nice, compact chunk of code. It's from a control program that runs a machine that makes candy bars.

```

int t = m.chkTemp();
if (t > 160) {
    T tb = new T();
    tb.clsTrpV(2);
    ics.Fill();
    ics.Vent();
    m.airsyschk();
}
    
```

"obj", "ics", and "m" are terrible names! We have no idea what they do. And what's that T class for?

The chkTemp() method returns an integer... but what does it do?

The clsTrpV() method has one parameter, but we don't know what it's supposed to be.

Take a second and look at that code. Can you figure out what it does?

- 2** Those statements don't give you any hints about why the code's doing what it's doing. In this case, the programmer was happy with the results because she was able to get it all into one method. But making your code as compact as possible isn't really useful! Let's break it up into methods to make it easier to read, and make sure the classes are given names that make sense. But we'll start by figuring out what the code is supposed to do.

How do you figure out what your code is supposed to do? Well, all code is written for a reason. So it's up to you to figure out that reason! In this case, we can look up the page in the specification manual that the programmer followed.

General Electronics Type 5 Candy Bar Maker Specification Manual

The nougat temperature must be checked every 3 minutes by an automated system. If the temperature **exceeds 160°C**, the candy is too hot, and the system must **perform the candy isolation cooling system (CICS) vent procedure**.

- Close the trip throttle valve on turbine #2
- Fill the isolation cooling system with a solid stream of water
- Vent the water
- Verify that there is no evidence of air in the system

- 3 That page from the manual made it a lot easier to understand the code. It also gave us some great hints about how to make our code easier to understand. Now we know why the conditional test checks the variable `t` against 160—the manual says that any temperature above 160°C means the nougat is too hot. And it turns out that “`m`” was a class that controlled the candy maker, with static methods to check the nougat temperature and check the air system. So let’s put the temperature check into a method, and choose names for the class and the methods that make the purpose obvious.

The `IsNougatTooHot()` method’s return type

```
public boolean IsNougatTooHot () {
    int temp = Maker.CheckNougatTemperature ();
    if (temp > 160) {
        return true;
    } else {
        return false;
    }
}
```

By naming the class “Maker” and the method “CheckNougatTemperature”, the code is a lot easier to understand.

This method’s return type is boolean, which means it returns a true or false value.

- 4 What does the specification say to do if the nougat is too hot? It tells us to perform the candy isolation cooling system (or CICS) vent procedure. So let’s make another method, and choose an obvious name for the “`T`” class (which turns out to control the turbine) and the “`ics`” class (which controls the isolation cooling system, and has two static methods to fill and vent the system):

A void return type means the method doesn’t return any value at all.

```
public void DoCICSVentProcedure () {
    Turbine turbineController = new Turbine ();
    turbineController.CloseTripValve (2);
    IsolationCoolingSystem.Fill ();
    IsolationCoolingSystem.Vent ();
    Maker.CheckAirSystem ();
}
```

- 5 Now the code’s a lot more intuitive! Even if you don’t know that the CICS vent procedure needs to be run if the nougat is too hot, **it’s a lot more obvious what this code is doing**:

```
if (IsNougatTooHot () == true) {
    DoCICSVentProcedure ();
}
```

You can make your code easier to read and write by thinking about the problem your code was built to solve. If you choose names for your methods that make sense to someone who understands that problem, then your code will be a lot easier to decipher...and develop!

Give your classes a natural structure

Take a second and remind yourself why you want to make your methods intuitive: **because every program solves a problem or has a purpose.** It might not be a business problem—sometimes a program’s purpose (like `FlashyThing`) is just to be cool or fun! But no matter what your program does, the more you can make your code resemble the problem you’re trying to solve, the easier your program will be to write (and read, and repair, and maintain...).

Use class diagrams to plan out your classes

A class diagram is a simple way to draw your classes out on paper. It’s a really valuable tool for designing your code **BEFORE** you start writing it.

Write the name of the class at the top of the diagram. Then write each method in the box at the bottom. Now you can see all of the parts of the class at a glance!

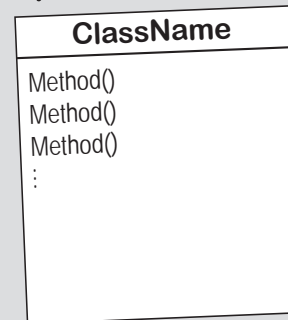

Let’s build a class diagram

Take another look at the `if` statement in #5 on the last page. You already know that statements always live inside methods, which always live inside classes, right? In this case, that `if` statement was in a method called `DoMaintenanceTests()`, which is part of the `CandyController` class. Now take a look at the code and the class diagram. See how they relate to each other?

```
public class CandyController {
    public void DoMaintenanceTests() {
        ...
        if (IsNougatTooHot() == true) {
            DoCICSVentProcedure();
        }
        ...
    }
    public void DoCICSVentProcedure() ...
    public boolean IsNougatTooHot() ...
}
```

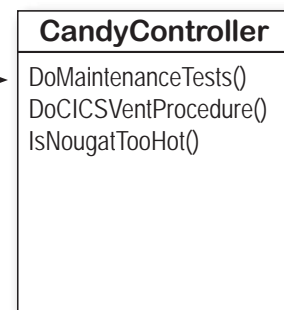



Sharpen your pencil



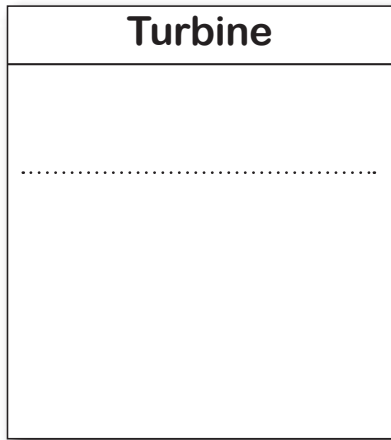

The code for the candy control system we built on the previous page called three other classes. Flip back and look through the code, and fill in their class diagrams.

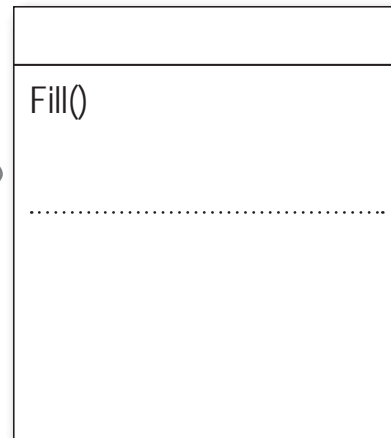

We filled in this class name for this one. What method goes here?

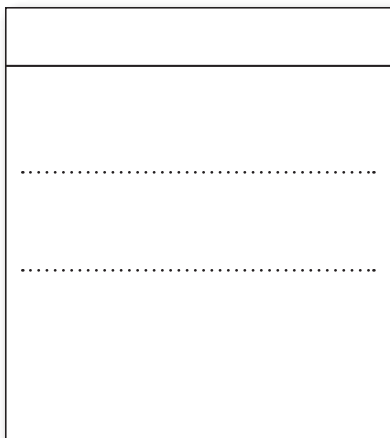

One of the classes had a method called Fill(). Fill in its class name and its other method.



There was one other class in the code on the previous page. Fill in its name and method.



Class diagrams help you organize your classes so they make sense

Writing out class diagrams makes it a lot easier to spot potential problems in your classes **before** you write code. Thinking about your classes from a high level before you get into the details can help you come up with a class structure that will make sure your code addresses the problems it solves. It lets you step back and make sure that you're not planning on writing unnecessary or poorly structured classes or methods, and that the ones you do write will be intuitive and easy to use.

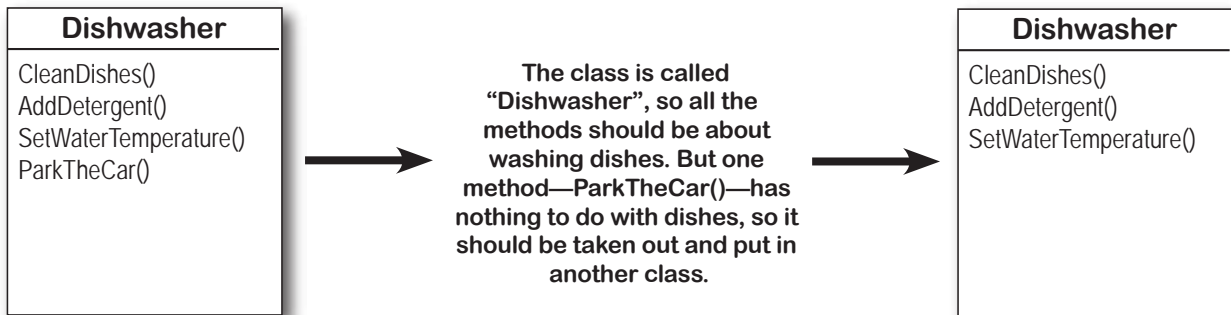

Sharpen your pencil Solution

The code for the candy control system we built on the previous page called three other classes. Flip back and look through the code, and fill in their class diagrams.

You could figure out that *Maker* is a class because it appears in front of a dot in *Maker.CheckAirSystem()*.

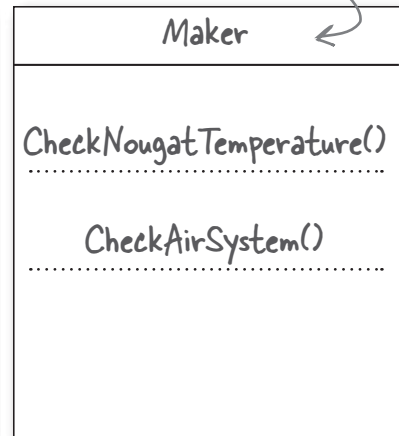
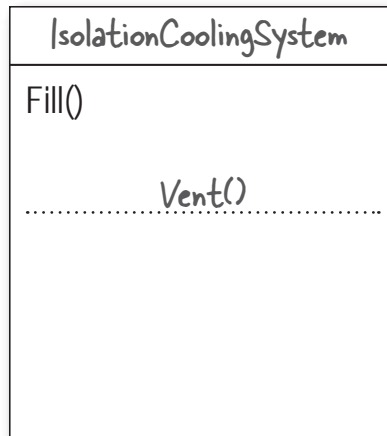
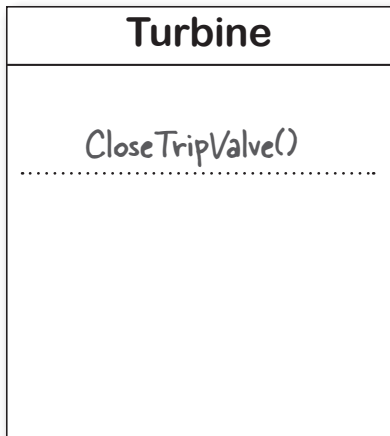



Each of these classes has a serious design flaw. Write down what you think is wrong with each class, and how you'd fix it.

```

Class23
CandyBarWeight()
PrintWrapper()
GenerateReport()
Go()
    
```

This class is part of the candy manufacturing system from earlier.

.....

.....

.....

.....

```

DeliveryGuy
AddAPizza()
PizzaDelivered()
TotalCash()
ReturnTime()
    
```

```

DeliveryGirl
AddAPizza()
PizzaDelivered()
TotalCash()
ReturnTime()
    
```

These two classes are part of a system that a pizza parlor uses to track the pizzas that are out for delivery.

.....

.....

.....

.....

```

CashRegister
MakeSale()
NoSale()
PumpGas()
Refund()
TotalCashInRegister()
GetTransactionList()
AddCash()
RemoveCash()
    
```

The `CashRegister` class is part of a program that's used by an automated convenience store checkout system.

.....

.....

.....

.....

Sharpen your pencil Solution



Here's how we corrected the classes. They're just one possible way to fix the problems—but there are plenty of other ways you could design these classes depending on how they'll be used.

This class is part of the candy manufacturing system from earlier.

The class name doesn't describe what the class does. A programmer who sees a line of code that calls `Class23.Go()` will have no idea what that line does. We'd also rename the method to something that's more descriptive—we chose `MakeTheCandy()`, but it could be anything.

CandyMaker
CandyBarWeight() PrintWrapper() GenerateReport() MakeTheCandy()

These two classes are part of a system that a pizza parlor uses to track the pizzas that are out for delivery.

It looks like the `DeliveryGuy` class and the `DeliveryGirl` class both do the same thing—they track a delivery person who's out delivering pizzas to customers. A better design would replace them with a single class that adds a field for gender.

DeliveryPerson
Gender
AddAPizza() PizzaDelivered() TotalCash() ReturnTime()

We added the `Gender` field because we assumed there was a reason to track both delivery guys and girls separately, and that's why there were two classes for them.

The `CashRegister` class is part of a program that's used by an automated convenience store checkout system.

All of the methods in the class do stuff that has to do with a cash register—making a sale, getting a list of transactions, adding cash... except for one: pumping gas. It's a good idea to pull that method out and stick it in another class.

CashRegister
MakeSale() NoSale() Refund() TotalCashInRegister() GetTransactionList() AddCash() RemoveCash()

```

public partial class Form1 : Form
{
    private void button1_Click(object sender, EventArgs e)
    {
        String result = "";
        Echo e1 = new Echo();

        _____

        int x = 0;
        while ( _____ ) {
            result = result + e1.hello() + "\n";

            _____

            if ( _____ ) {
                e2.count = e2.count + 1;
            }

            if ( _____ ) {
                e2.count = e2.count + e1.count;
            }

            x = x + 1;
        }
        MessageBox.Show(result + "Count: " + e2.count);
    }

    public class _____ {
        public int _____ = 0;
        public string _____ {
            return "hellooo...";
        }
    }
}

```



Pool Puzzle

Your **job** is to take code snippets from the pool and place them into the blank lines in the code. You **may** use the same snippet more than once, and you won't need to use all the snippets. Your **goal** is to make classes that will compile and run and produce the output listed.

Output

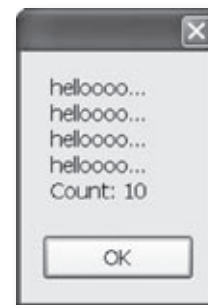

Bonus Question!

If the last line of output was **24** instead of **10** how would you complete the puzzle? You can do it by changing just one statement.

Note: Each snippet from the pool can be used more than once!

	x < 4		
x	x < 5	Echo	
y	x > 0	Tester	
e2	x > 1	echo()	e2 = e1;
count		count()	Echo e2;
e1 = e1 + 1;		hello()	Echo e2 = e1;
e1 = count + 1;			Echo e2 = new Echo();
e1.count = count + 1;			x == 3
e1.count = e1.count + 1;			x == 4

→ Answers on page 120.

you are here ▶

109

Build a class to work with some guys

Joe and Bob lend each other money all the time. Let's build a class to keep track of them.

Guy
Name Cash
GiveCash() ReceiveCash()

- We'll create a Guy class and add two instances of it to a form**
 The form will have two fields, one called joe (to keep track of the first object), and the other called bob (to keep track of the second object).

The new statements that create the two instances live in the code that gets run as soon as the form is created. Here's what the heap looks like after the form is loaded.

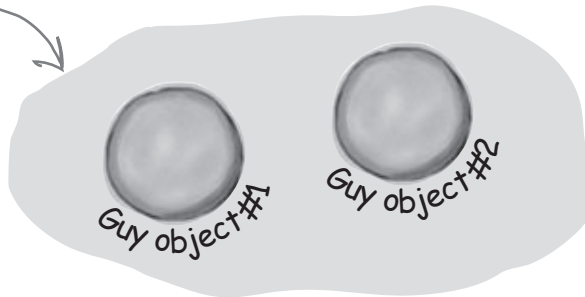

- We'll set each Guy object's cash and name**
 The two objects represent different guys, so each one has its own name and a different amount of cash in his pocket.

Each guy has a Name field that keeps track of his name, and a Cash field that has the number of bucks in his pocket.

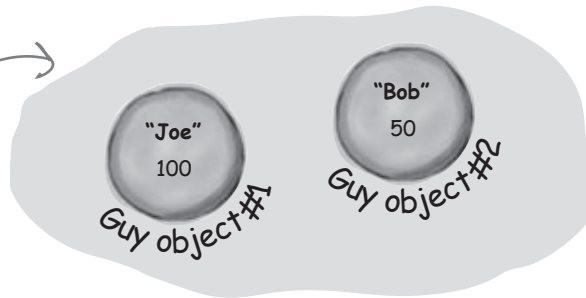

When you take an instance of Guy and call its ReceiveCash() method, you pass the amount of cash to take as a parameter. So calling joe.ReceiveCash(25) takes 25 bucks from Joe.

- We'll give cash to the guys and take cash from them**
 We'll use each guy's GiveCash() method to give cash to a guy, and we'll use his ReceiveCash() method to take cash back from him.

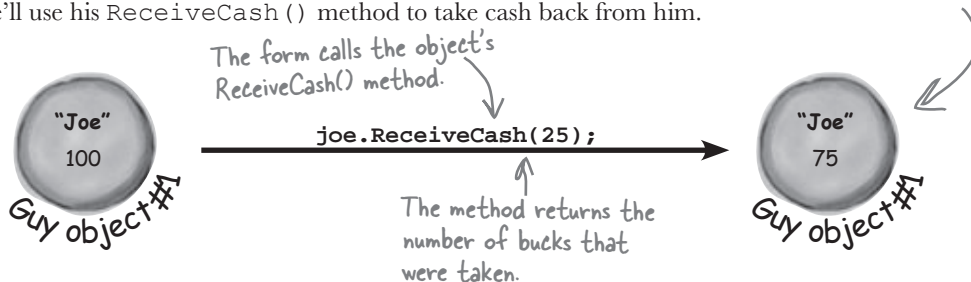

Create a project for your guys

Create a new Windows Forms Application project (because we'll be using a form). Then use the Solution Explorer to add a new class to it called Guy. Make sure to add "using System.Windows.Forms;" to the top of the Guy class file. Then fill in the Guy class. Here's the code for it:



```
public class Guy {
    public string Name;
    public int Cash;

    public int GiveCash(int amount) {
        if (amount <= Cash && amount > 0) {
            Cash -= amount;
            return amount;
        } else {
            MessageBox.Show(
                "I don't have enough cash to give you " + amount,
                Name + " says...");
            return 0;
        }
    }

    public int ReceiveCash(int amount) {
        if (amount > 0) {
            Cash += amount;
            return amount;
        } else {
            MessageBox.Show(amount + " isn't an amount I'll take",
                Name + " says...");
            return 0;
        }
    }
}
```

The Guy class has two fields. The Name field is a string, and it'll contain the guy's name ("Joe"). And the Cash field is an int, which will keep track of how many bucks are in his pocket.

The GiveCash() method has one parameter called amount that you'll use to tell the guy how much cash to give you.

He uses an if statement to check whether he has enough cash—if he does, he takes it out of his pocket and returns it as the return value.

If the guy doesn't have enough cash, he'll tell you so with a message box, and then he'll make GiveCash() return 0.

The ReceiveCash() method works just like the GiveCash() method. It's passed an amount as a parameter, checks to make sure that amount is greater than zero, and then adds it to his cash.

If the amount was positive, then the ReceiveCash() method returns the amount added. If it was zero or negative, the guy shows a message box and then returns 0.

The Guy makes sure that you're asking him for a positive amount of cash, otherwise he'd add to his cash instead of taking away from it.

Be careful with your curly brackets. It's easy to have the wrong number—make sure that every opening bracket has a matching closing bracket. When they're all balanced, the IDE will automatically indent them for you when you type the last closing bracket.

Build a form to interact with the guys

The Guy class is great, but it's just a start. Now put together a form that uses two instances of the Guy class. It's got labels that show you their names and how much cash they have, and buttons to give and take cash from them.



1 Add two buttons and three labels to your form

The top two labels show how much cash each guy has. We'll also add a variable called bank to the form—the third label shows how much cash is in it. We're going to have you name some of the labels that you drag onto the forms. You can do that by **clicking on each label** that you want to name and **changing its "(Name)" row** in the Properties window. That'll make your code a lot easier to read, because you'll be able to use "joesCash" and "bobsCash" instead of "label1" and "label2".

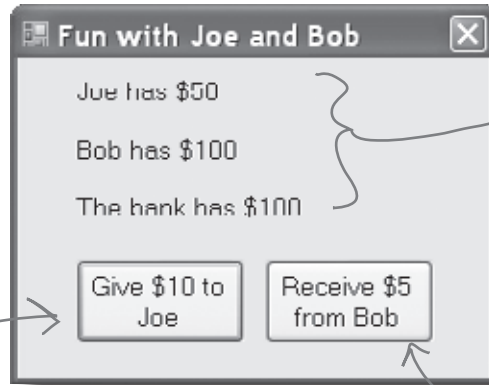

This button will call the Joe object's ReceiveCash() method, passing it 10 as the amount, and subtracting the cash it gives to Joe from the bank variable.

Name the top label joesCash, the label underneath it bobsCash, and the bottom label bankCash. You can leave their Text properties alone, we'll add a method to the form to set them.

This button will call the Bob object's GiveCash() method, passing it 5 as the amount, and adding the cash it receives from Joe to the bank variable.

2 Add variables to your form

Your form will need to keep track of the two guys, so you'll need a variable for each of them. Call them joe and bob. Then add a variable to the form called bank to keep track of how much money the form has to give to and receive from the guys.

```
namespace Your_Project_Name {  
    public partial class Form1 : Form {  
        Guy joe;  
        Guy bob;  
        int bank = 100;  
  
        public Form1() {  
            InitializeComponent();  
        }  
    }  
}
```

Since we're using Guy objects to keep track of Joe and Bob, you declare their variables using Guy.

The amount of cash in the bank goes up and down depending on how much money the form gave to and received from the Guy objects.

3 Add a method to the form to update the labels

The labels on the right-hand side of the form show how much cash each guy has and how much is in the bank variable. So add the `UpdateForm()` method to keep them up to date—**make sure the return type is `void`** to tell C# that the method doesn't return a value. Type this method into the form right underneath where you added the bank variable:

```
public void UpdateForm() {
    joesCash.Text = joe.Name + " has $" + joe.Cash;
    bobsCash.Text = bob.Name + " has $" + bob.Cash;
    bankCash.Text = "The bank has $" + bank;
}
```

Notice how the labels are updated using the Guy objects' Name and Cash fields.

This new method is simple. It just updates the three labels by setting their Text properties. You'll have each button call it to keep the labels up to date.

4 Double-click on each button and add the code to interact with the objects

Make sure the left-hand button is called `button1`, and the right-hand button is called `button2`. Then double-click each of the buttons—when you do, the IDE will add two methods called `button1_Click()` and `button2_Click()` to the form. Add this code to each of them:

```
private void button1_Click(object sender, EventArgs e) {
    if (bank >= 10) {
        bank -= joe.ReceiveCash(10);
        UpdateForm();
    } else {
        MessageBox.Show("The bank is out of money.");
    }
}

private void button2_Click(object sender, EventArgs e) {
    bank += bob.GiveCash(5);
    UpdateForm();
}
```

When the user clicks the "Give \$10 to Joe" button, the form calls the Joe object's `ReceiveCash()` method—but only if the bank has enough money.

The bank needs at least \$10 to give to Joe. If there's not enough, it'll pop up this message box.

The "Receive \$5 from Bob" button doesn't need to check how much is in the bank, because it'll just add whatever Bob gives back.

If Bob's out of money, `GiveCash()` will return zero.

5 Start Joe out with \$50 and start Bob out with \$100

It's up to you to **figure out how to get Joe and Bob to start out with their Cash and Name fields set properly**. Put it right underneath `InitializeComponent()` in the form. That's part of a special method that gets run once, when the form is first initialized. Once you've done that, click both buttons a number of times—make sure that one button takes \$10 from the bank and adds it to Joe, and the other takes \$5 from Bob and adds it to the bank.

```
public Form() {
    InitializeComponent();
    // Initialize joe and bob here!
}
```

Add the lines of code here to create the two objects and set their Name and Cash fields.



Exercise



Exercise Solution

It's up to you to **figure out how to get Joe and Bob to start out with their Cash and Name fields set properly.** Put it right underneath `InitializeComponent()`

Here's where we set up the first instance of `Guy`. The first line creates the object, and the next two set its fields.

```
public Form1() {
    InitializeComponent();
```

```
    bob = new Guy();
    bob.Name = "Bob";
    bob.Cash = 100;
```

```
    joe = new Guy();
    joe.Name = "Joe";
    joe.Cash = 50;
```

Then we do the same for the second instance of the `Guy` class.

Make sure you call `UpdateForm()` so the labels look right when the form first pops up.

```
    UpdateForm();
}
```

there are no Dumb Questions

Make sure you save the project now—we'll come back to it in a few pages.

Q: Why doesn't the solution start with `"Guy bob = new Guy()"`? Why did you leave off the first `"Guy"`?

A: Because you already declared the `bob` field at the top of the form. Remember how the statement `"int i = 5;"` is the same as the two statements `"int i"` and `"i = 5;"`? This is the same thing. You could try to declare the `bob` field in one line like this: `"Guy bob = new Guy();"`. But you already have the first part of that statement (`"Guy bob;"`) at the top of your form. So you only need the second half of the line, the part that sets the `bob` field to create a new instance of `Guy()`.

Q: Okay, so then why not get rid of the `"Guy bob;"` line at the top of the form?

A: Then the `bob` variable will only exist inside that special `"public Form1()"` method. When you declare a variable inside a method, it's only valid inside the method—you can't access it from any other method. But when you declare it outside of your method but inside the form or a class that you added, then you can access it from *any other method* inside the form or class.

Q: What happens if I don't leave off that first `"Guy"`?

A: You'll run into problems—your form won't work, because it won't ever set the form's `bob` variable. Think about it for a minute, and you'll see why it works that way. If you have this code at the top of your form:

```
public partial class Form1 : Form {
    Guy bob;
```

and then you have this code later on, inside a method:

```
Guy bob = new Guy();
```

then you've declared *two* variables. It's a little confusing, because they both have the same name. But one of them is valid throughout the entire form, and the other one—the new one you added—is only valid inside the method. The next line (`bob.Name = "Bob";`) only updates that *local* variable, and doesn't touch the one in the form. So when you try to run your code, it'll give you a nasty error message (`"NullReferenceException not handled"`), which just means you tried to use an object before you created it with `new`.

There's an even easier way to initialize objects

Almost every object that you create needs to be initialized in some way. And the `Guy` object is no exception—it's useless until you set its `Name` and `Cash` fields. It's so common to have to initialize fields that C# gives you a shortcut for doing it called an **object initializer**. And the IDE's IntelliSense will help you do it.



Object initializers only work with C# 3.0.

If you're running Visual Studio 2005, then this won't work. Definitely consider downloading Visual Studio 2008 Express Edition—it's free, and you can install it alongside your existing VS2005 installation.

- 1 Here's the original code that you wrote to initialize Joe's `Guy` object.

```
joe = new Guy();
joe.Name = "Joe";
joe.Cash = 50;
```

- 2 Delete the second two lines, and the semicolon after "`Guy()`" and add a right curly bracket.

```
joe = new Guy() {
```

- 3 Press space. As soon as you do, the IDE pops up an IntelliSense window that shows you all of the fields that you're able to initialize.

```
joe = new Guy() {
```



- 4 Press tab to tell it to add the `Cash` field. Then set it equal to 50.

```
joe = new Guy() { Cash = 50
```

- 5 Type in a comma. As soon as you do, the other field shows up.

```
joe = new Guy() { Cash = 50,
```

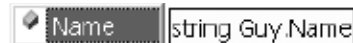

- 5 Finish the object initializer. Now you've saved yourself two lines of code!

```
joe = new Guy() { Cash = 50, Name = "Joe" };
```

This new declaration does exactly the same thing as the three lines of code you wrote originally. It's just shorter and easier to read.

**Object
initializers
save you time
and make
your code
more compact
and easier to
read... and the
IDE helps you
write them.**

A few ideas for designing intuitive classes

★ **You're building your program to solve a problem.**

Spend some time thinking about that problem. Does it break down into pieces easily? How would you explain that problem to someone else? These are good things to think about when designing your classes.

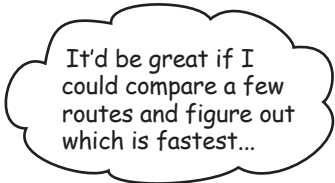

★ **What real-world things will your program use?**

A program to help a zoo keeper track her animals' feeding schedules might have classes for different kinds of food and types of animals.



★ **Use descriptive names for classes and methods.**

Someone should be able to figure out what your classes and methods do just by looking at their names.

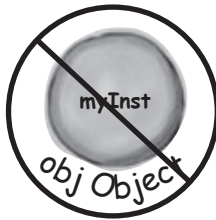

★ **Look for similarities between classes.**

Sometimes two classes can be combined into one if they're really similar. The candy manufacturing system might have three or four turbines, but there's only one method for closing the trip valve that takes the turbine number as a parameter.

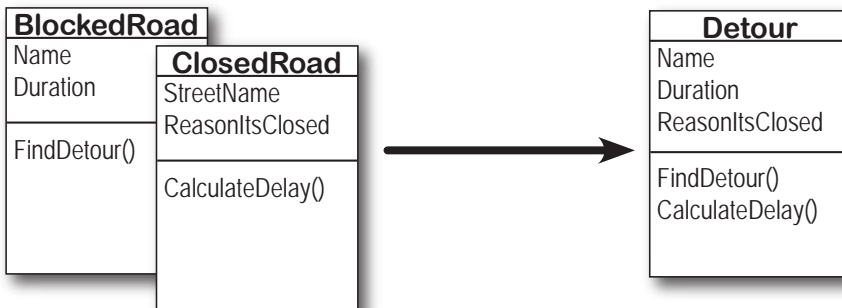



Exercise

Add buttons to the “Fun with Joe and Bob” program to make the guys give each other cash.

1 Use an object initializer to initialize Bob's instance of Guy

You've already done it with Joe. Now make Bob's instance work with an object initializer too.

If you already clicked the button, just delete it, add it back to your form, and rename it. Then delete the old `button3_Click()` method that the IDE added before, and use the new method it adds now.

2 Add two more buttons to your form

The first button tells Joe to give 10 bucks to Bob, and the second tells Bob to give 5 bucks back to Joe. **Before you double-click on the button**, go to the Properties window and change each button's name using the “(Name)” row—it's **at the top** of the list of properties. Name the first button `joeGivesToBob`, and the second one `bobGivesToJoe`.

This button tells Joe to give 10 bucks to Bob, so you should use the “(Name)” row in the Properties window to name it `joeGivesToBob`.

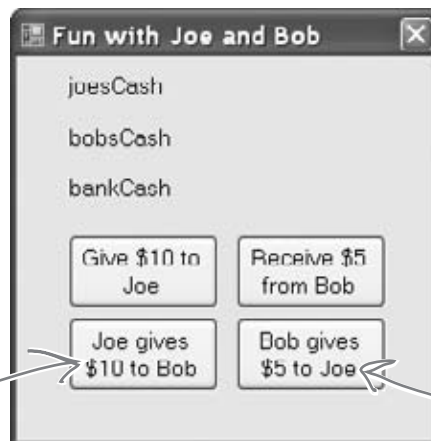

This button tells Bob to give 5 bucks to Joe. Name it `bobGivesToJoe`.

3 Make the buttons work

Double-click on the `joeGivesToBob` button in the designer. The IDE will add a method to the form called `joeGivesToBob_Click()` that gets run any time the button's clicked. Fill in that method to make Joe give 10 bucks to Bob. Then double-click on the other button and fill in the new `bobGivesToJoe_Click()` method that the IDE creates so that Bob gives five bucks to Joe. Make sure the form updates itself after the cash changes hands.



Exercise Solution

Add buttons to the "Fun with Joe and Bob" program to make the guys give each other cash.

```

public partial class Form1 : Form {
    Guy joe;
    Guy bob;
    int bank = 100;

    public Form1() {
        InitializeComponent();
        bob = new Guy() { Cash = 100, Name = "Bob" };
        joe = new Guy() { Cash = 50, Name = "Joe" };
        UpdateForm();
    }

    public void UpdateForm() {
        joesCash.Text = joe.Name + " has $" + joe.Cash;
        bobsCash.Text = bob.Name + " has $" + bob.Cash;
        bankCash.Text = "The bank has $" + bank;
    }

    private void button1_Click(object sender, EventArgs e) {
        if (bank >= 10) {
            bank -= joe.ReceiveCash(10);
            UpdateForm();
        } else {
            MessageBox.Show("The bank is out of money.");
        }
    }

    private void button2_Click(object sender, EventArgs e) {
        bank += bob.GiveCash(5);
        UpdateForm();
    }

    private void joeGivesToBob_Click(object sender, EventArgs e) {
        bob.ReceiveCash(joe.GiveCash(10));
        UpdateForm();
    }

    private void bobGivesToJoe_Click(object sender, EventArgs e) {
        joe.ReceiveCash(bob.GiveCash(5));
        UpdateForm();
    }
}

```

Here are the object initializers for the two instances of the Guy class. Bob gets initialized with 100 bucks and his name.

To make Joe give cash to Bob, we call Joe's GiveCash() method and send its results into Bob's ReceiveCash() method.

Take a close look at how the Guy methods are being called. The results returned by GiveCash() are pumped right into ReceiveCash() as its parameter.

The trick here is thinking through who's giving the cash and who's receiving it.



Objectcross

It's time to give your left brain a break, and put that right brain to work: all the words are object-related and from this chapter.

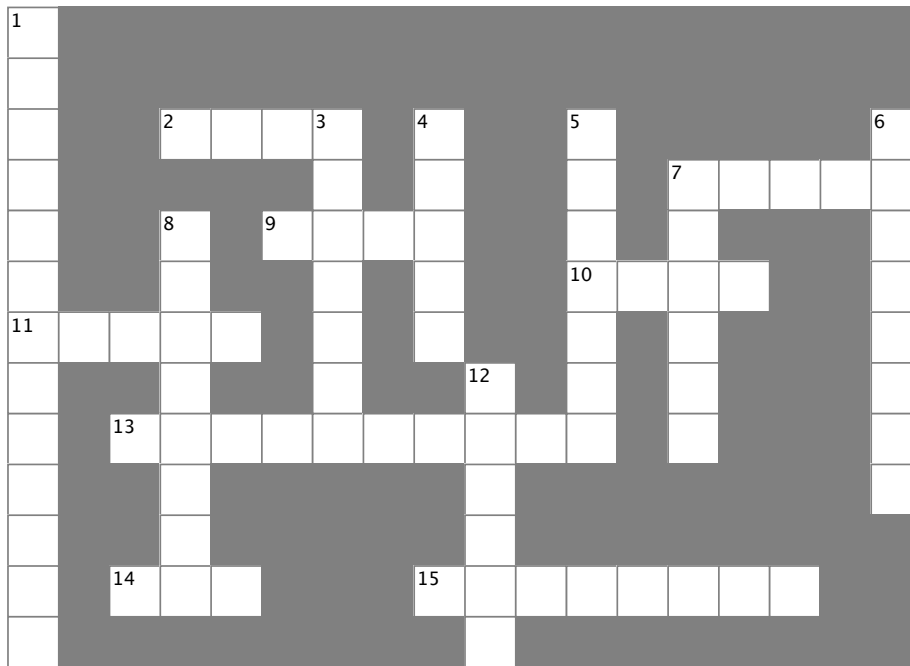

Across

2. If a method's return type is _____, it doesn't return anything
7. An object's fields define its _____
9. A good method _____ makes it clear what the method does
10. Where objects live
11. What you use to build an object
13. What you use to pass information into a method
14. The statement you use to create an object
15. A special kind of field that's used by the form controls

Down

1. This form control lets the user choose a number from a range you set
3. It's a great idea to create a class _____ on paper before you start writing code
4. What an object uses to keep track of what it knows
5. These define what an object does
6. An object's methods define its _____
7. Don't use this keyword in your class declaration if you want to be able to create instances of it
8. An object is an _____ of a class
12. This statement tells a method to immediately exit, and specifies the value that should be passed back to the statement that called the method



Pool Puzzle Solution

Your **job** was to take code snippets from the pool and place them into the blank lines in the code. Your **goal** was to make classes that will compile and run and produce the output listed.

```
public partial class Form1 : Form
{
    private void button1_Click(object sender, EventArgs e)
    {
        String result = "";
        Echo e1 = new Echo();
        Echo e2 = new Echo();
        int x = 0;
        while ( x < 4 ) {
            result = result + e1.hello() + "\n";
            e1.count = e1.count + 1;
            if ( x == 3 ) {
                e2.count = e2.count + 1;
            }
            if ( x > 0 ) {
                e2.count = e2.count + e1.count;
            }
            x = x + 1;
        }
        MessageBox.Show(result + "Count: " + e2.count);
    }

    public class Echo {
        public int count = 0;
        public string hello() {
            return "helloooo...";
        }
    }
}
```

That's the correct answer.

And here's the bonus answer!

Echo e2 = e1;



Objectcross Solution

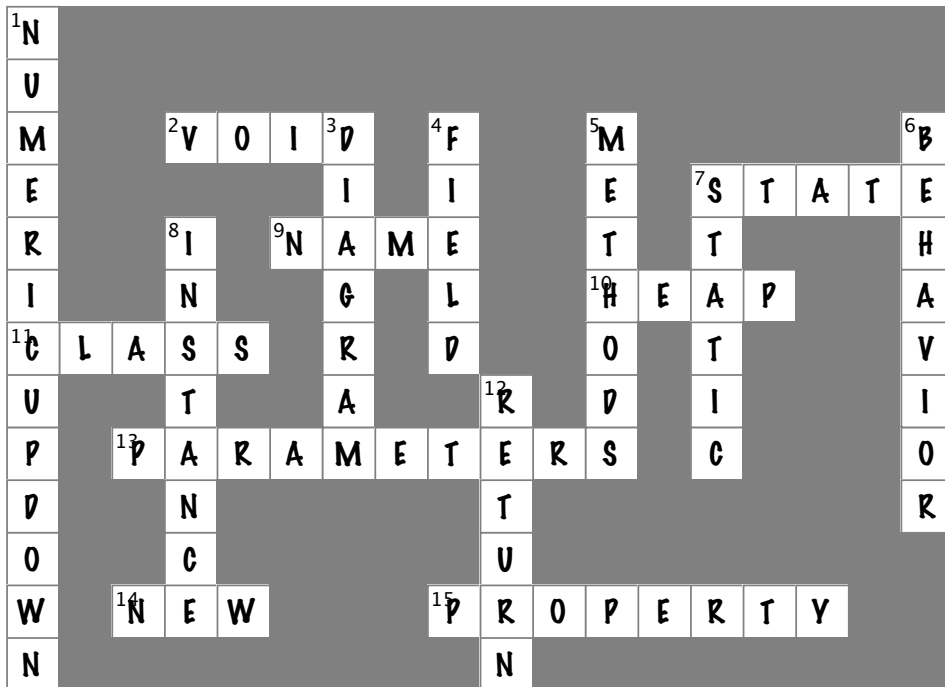

4 Types and References

It's 10:00. ✨

✨ Do you know where your data is? ✨

This data just got garbage collected.



Data type, database, Lieutenant Commander Data...

it's all important stuff. Without data, your programs are useless. You need **information** from your users, and you use that to look up or produce new information, to give back to them. In fact, almost everything you do in programming involves **working with data** in one way or another. In this chapter, you'll learn the ins and outs of C#'s **data types**, how to work with data in your program, and even figure out a few dirty secrets about **objects** (*psstt... objects are data, too*).

The variable's type determines what kind of data it can store

There are fifteen **types** built into C#, and each one stores a different kind of data. You've already seen some of the most common ones, and you know how to use them. But there are a few that you haven't seen, and they can really come in handy, too.

Types you'll use all the time

It shouldn't come as a surprise that `int`, `string`, `bool`, and `float` are the most common types.

- ★ `int` can store any **whole** number from -2,147,483,648 to 2,147,483,647.
- ★ `string` can hold text of any length (including the empty string "").
- ★ `bool` is a Boolean value—it's either `true` or `false`.
- ★ `float` can store any **decimal** number from $\pm 1.5 \times 10^{-45}$ to $\pm 3.4 \times 10^{38}$ with up to 7 significant figures. That range looks weird and complicated, but it's actually pretty simple. The "significant figures" part means the *precision* of the number: 35,048,410,000,000, 1,743,059, 14.43857, and 0.00004374155 all have seven significant figures. The 10^{38} thing means that you can store any number as large as 10^{38} (or 1 followed by 38 zeroes)—as long as it only has 7 or fewer significant figures. On the other end of the range, 10^{-45} means that you can store any number as small as 10^{-45} (or a decimal point followed by 45 zeroes followed by 1)... but, you guessed it, as long as it only has 7 or fewer significant figures.

A whole number doesn't have a decimal point.

"float" is short for "floating point"—as opposed to a "fixed point" number, which always has the same number of decimal places.

The "u" in `uint` stands for "unsigned", which means it can't be negative (so there's no minus sign).

More types for whole numbers

Once upon a time, computer memory was really expensive, and processors were really slow. And, believe it or not, if you used the wrong type, it could seriously slow down your program. Luckily, times have changed, and most of the time if you need to store a whole number you can just use an `int`. But sometimes you really need something bigger... and once in a while, you need something smaller, too. That's why C# gives you more options:

- ★ `byte` can store any **whole** number between 0 and 255.
- ★ `sbyte` can store any **whole** number from -128 to 127.
- ★ `short` can store any **whole** number from -32,768 to 32,767.
- ★ `ushort` can store any **whole** number from 0 to 65,535.
- ★ `uint` can store any **whole** number from 0 to 4,294,967,295.
- ★ `long` can store any number between minus and plus 9 billion billion.
- ★ `ulong` can store any number between 0 and about 18 billion billion.

A lot of times, if you're using these types it's because you're solving a problem where it really helps to have the "wrapping around" effect that you'll read about in a few minutes.

The "u" stands for "unsigned"

Types for storing *really* HUGE and *really* tiny numbers

Sometimes 7 significant figures just isn't precise enough. And, believe it or not, sometimes 10^{38} isn't big enough and 10^{-45} isn't small enough. A lot of programs written for finance or scientific research run into these problems all the time, so C# gives us two more types:

When your program needs to deal with currency, you usually want to use a decimal to store the number.

★ `double` can store any number from $\pm 5.0 \times 10^{-324}$ to $\pm 1.7 \times 10^{308}$ with 15–16 significant digits.

★ `decimal` can store any number from $\pm 1.0 \times 10^{-28}$ to $\pm 7.9 \times 10^{28}$ with 28–29 significant digits.

Literals have types, too

A literal just means a number that you type into your code. So when you type "`int i = 5;`", the 5 is a literal.

When you type a number directly into your C# program, you're using a **literal**... and every literal is automatically assigned a type. You can see this for yourself—just enter this line of code that assigns the literal 14.7 to an `int` variable:

```
int myInt = 14.7;
```

Now try to build the program. You'll get this:

❗ 1 Cannot implicitly convert type 'double' to 'int'. An explicit conversion exists (are you missing a cast?)

That's the same error you'll get if you try to set an `int` equal to a `double` variable. What the IDE is telling you is that the literal 14.7 has a type—it's a `double`. You can change its type to a `float` by sticking an F on the end (14.7F). And 14.7M is a decimal.

A few more useful built-in types

Sometimes you need to store a single character like Q or 7 or \$, and when you do you'll use the `char` type. Literal values for `char` are always inside single quotes ('x', '3'). You can include **escape sequences** in the quotes, too ('\n' is a line break, '\t' is a tab). You write an escape sequence in your C# code using two characters, but your program stores each escape sequence as a single character in memory.

And finally, there's one more important type: **object**. You've already seen how an object can inherit from another one, and that object can in turn inherit from yet a different object. At the top of every inheritance hierarchy is the `object` class—that's a special type that every other object inherits from. That's really useful, because it means that **you can assign any value, variable, or object to an object variable**.

The `double` type is actually **as common as float**. A lot of people use it all the time, and rarely use `float`.

When you used the `Value` property in your `numericUpDown` control, you were using a decimal.

If you try to assign a float literal to a `double` or a decimal literal to a `float`, the IDE will give you a helpful message reminding you to add the right suffix. Cool!

You'll learn a lot more about how `char` and `byte` relate to each other in Chapter 9.



You can use the Windows calculator to convert between decimal (normal, base-10) numbers and binary numbers (base-2 numbers written with only ones and zeroes)—put it in Scientific mode, enter a number, and click the **Bin** radio button to convert to binary. Then click **Dec** to convert it back. Now **enter some of the upper and lower limits for the whole number types** (like -32,768 and 255) and convert them to binary. Can you figure out **why** C# gives you those particular limits?

A variable is like a data to-go cup

All of your data takes up space in memory. (Remember the heap from last chapter?) So part of your job is to think about how *much* space you're going to need whenever you use a string or a number in your program. That's one of the reasons you use variables. They let you set aside enough space in memory to store your data.

Think of a variable like a cup that you keep your data in. C# uses a bunch of different kinds of cups to hold different kinds of data. And just like the different sizes of cups at the coffee shop, there are different sizes of variables, too.

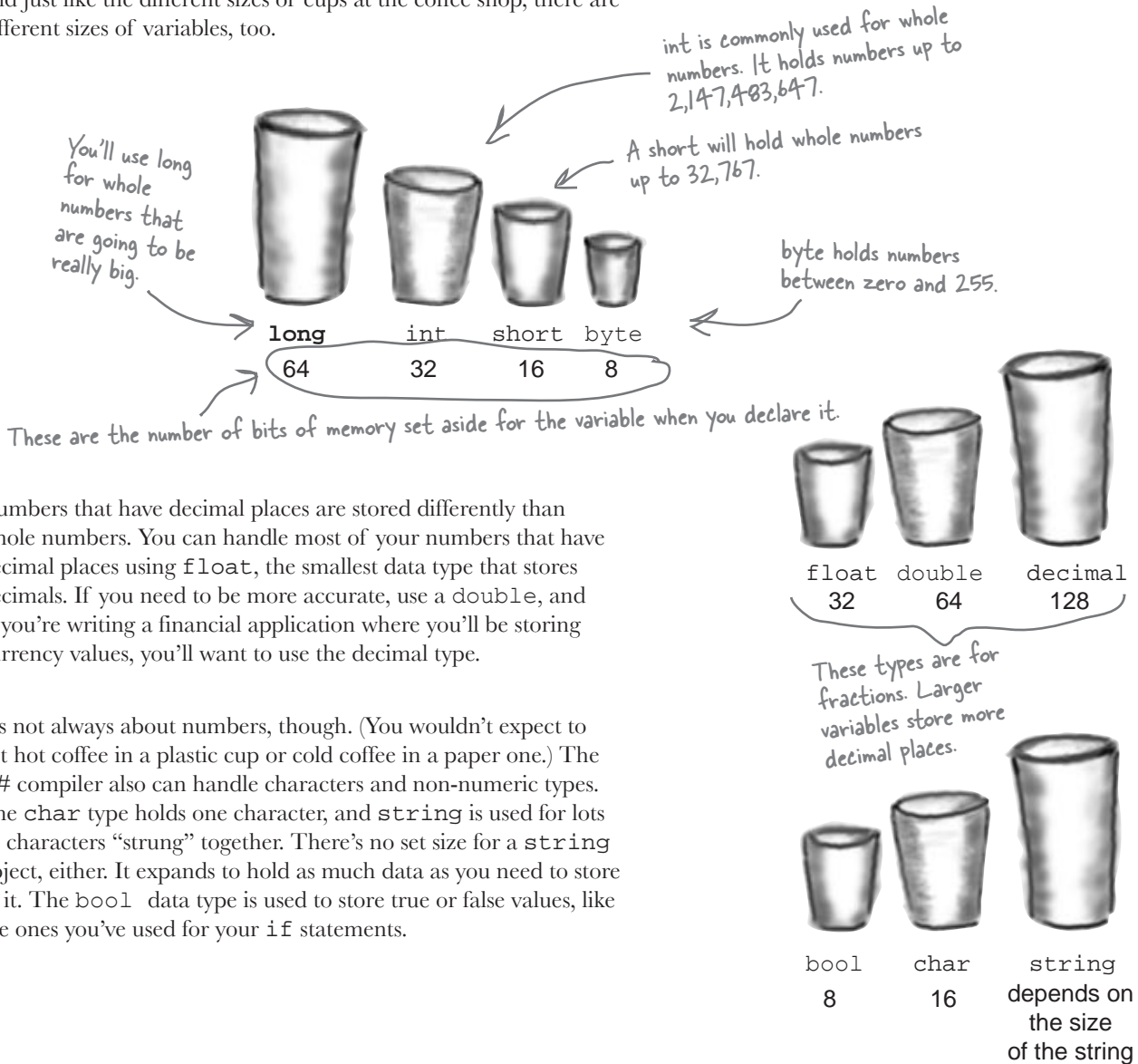

Numbers that have decimal places are stored differently than whole numbers. You can handle most of your numbers that have decimal places using `float`, the smallest data type that stores decimals. If you need to be more accurate, use a `double`, and if you're writing a financial application where you'll be storing currency values, you'll want to use the `decimal` type.

It's not always about numbers, though. (You wouldn't expect to get hot coffee in a plastic cup or cold coffee in a paper one.) The C# compiler also can handle characters and non-numeric types. The `char` type holds one character, and `string` is used for lots of characters "strung" together. There's no set size for a `string` object, either. It expands to hold as much data as you need to store in it. The `bool` data type is used to store true or false values, like the ones you've used for your `if` statements.

10 pounds of data in a 5 pound bag



When you declare your variable as one type, that's how your compiler looks at it. Even if the value is nowhere near the upper boundary of the type you've declared, the compiler will see the cup it's in, not the number inside. So this won't work:

```
int leaguesUnderTheSea = 20000;
short smallerLeagues = leaguesUnderTheSea;
```

20,000 would fit into a `short`, no problem. But since `leaguesUnderTheSea` is declared as an `int`, the compiler sees it as `int`-sized and considers it too big to put in a `short` container. The compiler won't make those translations for you on the fly. You need to make sure that you're using the right type for the data you're working with.

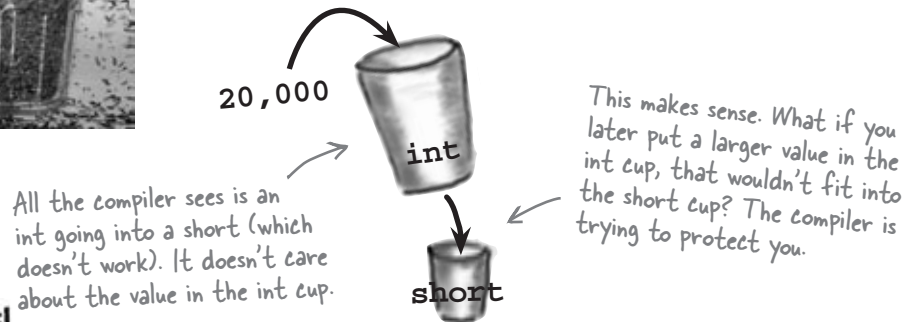

Sharpen your pencil

Three of these statements won't compile, either because they're trying to cram too much data into a small variable or because they're putting the wrong type of data in. Circle them.

```
int hours = 24;
```

```
string taunt = "your mother";
```

```
short y = 78000;
```

```
byte days = 365;
```

```
bool isDone = yes;
```

```
long radius = 3;
```

```
short RPM = 33;
```

```
char initial = 'S';
```

```
int balance = 345667 - 567;
```

```
string months = "12";
```

Even when a number is the right size, you can't just assign it to any variable

Let's see what happens when you try to assign a decimal value to an int variable.



- 1 Create a new project and add a button to it. Then add these lines to the button's **Click()** method:

```
decimal myDecimalValue = 10;
int myIntValue = myDecimalValue;

MessageBox.Show("The myIntValue is " + myIntValue);
```

- 2 Try building your program. Uh-oh—you got an error that looks like this:

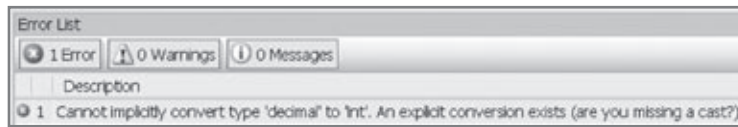

Check out how the IDE figured out that you were probably missing a cast.

- 3 Make the error go away by **casting** the decimal to an int. Once you change the second line so it looks like this, your program will compile and run:

```
int myIntValue = (int) myDecimalValue;
```

Here's where you cast the decimal value to an int.

So what happened?

The compiler won't let you assign a value to a variable if it's the wrong type—even if that variable can hold the value just fine—because that's the underlying cause behind an enormous number of bugs. When you use casting, you're essentially making a promise to the compiler that you know the types are different, and that in this particular instance it's okay for C# to cram the data into the new variable.

Take a minute to flip back to the beginning of the last chapter and check out how you used casting when you passed the `NumerickUpDown` value to the `Talker Tester` form.

Sharpen your pencil Solution

```
short y = 78000;
```

```
bool isDone = yes;
```

The short type holds numbers from -32,767 to 32,768. This number's too big!

You can only assign a value of "true" or "false" to a bool.

```
byte days = 365;
```

A byte can only hold a value of up to 256. You'll need a short for this.

When you cast a value that's too big, C# will adjust it automatically

You've already seen that a decimal can be cast to an int. It turns out that *any* number can be cast to *any other* number. But that doesn't mean the **value** stays intact through the casting. If you cast an int variable that's set to 365 to a byte variable, 365 is too big for the **byte**. But instead of giving you an error, the value will just **wrap around**: for example, 256 cast to a byte will have a value of 0. 257 would be converted to 1, 258 to 2, etc., up to 365, which will end up being **109**. And once you get back to 255 again, the conversion value "wraps" back to zero.



Hey, I've been combining numbers and strings in my message boxes since I learned about loops in Chapter 2! Have I been converting types all along?

Yes! The + operator converts for you.

What you've been doing is using the + operator, which **does a lot of converting for you automatically**—but it's especially smart about it. When you use + to add a number or boolean to a string, then it'll automatically convert that value to a string, too. If you use + (or *, / or -) with two different types, it **automatically converts the smaller type to the bigger one**.

Here's an example:

```
int myInt = 36;
float myFloat = 16.4F;
myFloat = myInt + myFloat;
```

Since an int can fit into a float but a float can't fit into an int, the + operator converts myInt to a float before adding it to myFloat.

When you're assigning a number value to a float, you need to add an F to the end of the number to tell the compiler that it's a float, and not a double.

Wrap it yourself!

There's no mystery to how casting "wraps" the numbers—you can do it yourself. Just pop up the Windows calculator, switch it to Scientific mode, and calculate 365 Mod 256 (using the "Mod" button, which does a modulo calculation). You'll get 109.

Sharpen your pencil

You can't always cast any type to any other type. Create a new project, drag a button onto a form, and type these statements into its method. Then build your program—it will give lots of errors. Cross out the ones that give errors. That'll help you figure out which types can be cast, and which can't!

```
int myInt = 10;

byte myByte = (byte)myInt;

double myDouble = (double)myByte;

bool myBool = (bool)myDouble;

string myString = "false";

myBool = (bool)myString;

myString = (string)myInt;

myString = myInt.ToString();

myBool = (bool)myByte;

myByte = (byte)myBool;

short myShort = (short)myInt;

char myChar = 'x';

myString = (string)myChar;

long myLong = (long)myInt;

decimal myDecimal = (decimal)myLong;

myString = myString + myInt + myByte + myDouble + myChar;
```

C# does some casting automatically

There are two important conversions that don't require you to do the casting. The first is done automatically any time you use arithmetic operators, like in this example:

```
long l = 139401930;
short s = 516;
double d = l - s;
d = d / 123.456;
MessageBox.Show("The answer is " + d);
```

The - operator subtracted the short from the long, and the = operator converted the result to a double.

This + operator is smart enough to convert the decimal to a string.

The other way C# converts types for you automatically is when you use the + operator to **concatenate** strings (which just means sticking one string on the end of another, like you've been doing with message boxes). When you use + to concatenate a string with something that's another type, it automatically converts the numbers to strings for you. Here's an example. The first two lines are fine, but the third one won't compile.

```
long x = 139401930;
MessageBox.Show("The answer is " + x);
MessageBox.Show(x);
```

The C# compiler spits out an error that mentions something about invalid arguments (an argument is what C# calls the value that you're passing into a method's parameter). That's because the parameter for **MessageBox.Show()** is a string, and this code passed a long, which is the wrong type for the method. But you can convert it to a string really easily by calling its **ToString()** method. That method is a member of every value type and object. (All of the classes you build yourself have a **ToString()** method that returns the class name.) That's how you can convert **x** to something that **MessageBox.Show()** can use:

```
MessageBox.Show(x.ToString());
```

Sharpen your pencil Solution

You can't always cast any type to any other type. Create a new project, drag a button onto a form, and type these statements into its method. Then build your program—it will give lots of errors. Cross out the ones that give errors. That'll help you figure out which types can be cast, and which can't!

```
int myInt = 10;
byte myByte = (byte)myInt;
double myDouble = (double)myByte;
bool myBool = (bool)myDouble;
string myString = "false";
myBool = (bool)myString;
myString = (string)myInt;
myString = myInt.ToString();
myBool = (bool)myByte;
myByte = (byte)myBool;
short myShort = (short)myInt;
char myChar = 'x';
myString = (string)myChar;
long myLong = (long)myInt;
decimal myDecimal = (decimal)myLong;
myString = myString + myInt + myByte
+ myDouble + myChar;
```

When you call a method, the variables must match the types of the parameters

Try calling `MessageBox.Show(123)`—passing `MessageBox.Show()` a literal (123) instead of a string. The IDE won't let you build your program. Instead, it'll show you an error in the IDE: "Argument '1': cannot convert from 'int' to 'string'." Sometimes C# can do the conversion automatically—like if your method expects an int, but you pass it a short—but it can't do that for ints and strings

But `MessageBox.Show()` isn't the only method that will give you compiler errors if you try to pass it a variable whose type doesn't match the parameter. *All* methods will do that, even the ones you write yourself. Go ahead and try typing this completely valid method into a class:

```
public int MyMethod(bool yesNo) {
    if (yesNo) {
        return 45;
    } else {
        return 61;
    }
}
```

One reminder—the code that calls this parameter doesn't have to pass it a variable called `yesNo`. It just has to pass it a boolean value or variable. The only place it's called `yesNo` is inside the method's code.

It works just fine if you pass it what it expects (a `bool`)—call `MyMethod(true)` or `MyMethod(false)`, and it compiles just fine.

But what happens if you pass it an integer or a string instead? The IDE gives you a similar error to the one that you got when you passed 123 to `MessageBox.Show()`. Now try passing it a boolean, but assigning the return value to a string or passing it on to `MessageBox.Show()`. That won't work, either—the method returns an `int`, not a long or the `string` that `MessageBox.Show()` expects.

You can assign anything to a variable, parameter, or field with the type object.

if statements always test to see if something's true

Did you notice how we wrote our if statement like this:

```
if (yesNo) {
```

We didn't have to explicitly say "if (`yesNo == true`)". That's because an if statement always checks if something's true. You check if something's false using ! (an exclamation point, or the NOT operator). "if (`!yesNo`)" is the same thing as "if (`yesNo == false`)". In our code examples from now on, you'll usually just see us do "if (`yesNo`)" or "if (`!yesNo`)", and not explicitly check to see if a boolean is true or false.

When the compiler gives you an "invalid arguments" error, it means that you tried to call a method with variables whose types didn't match the method's parameters.



Exercise

Create a reimbursement calculator for a business trip. It should allow the user to enter a starting and ending mileage reading from the car's odometer. From those two numbers, it will calculate how many miles she's travelled and figure out how much she should be reimbursed if her company pays her \$.39 for every mile she puts on her car.

1 Start with a new Windows project.

Make the form look like this:

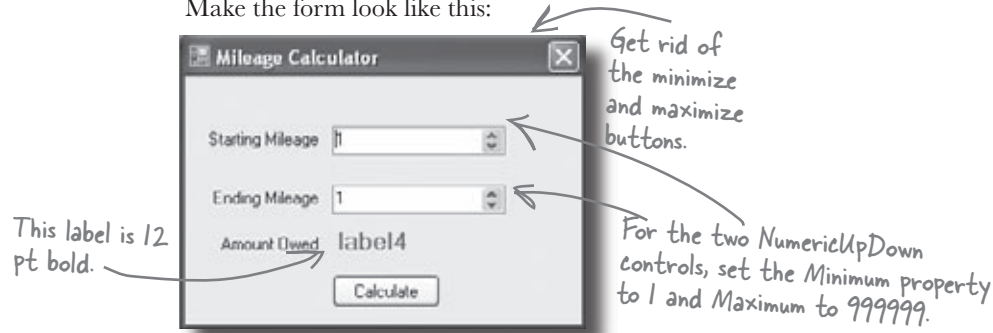

When you're done with the Form, double-click on the button to add some code to the project.

2 Create the variables you'll need for the calculator.

Put the variables in class definition at the top of `Form1`. You need two whole number variables to track the starting odometer reading and the ending odometer reading. Call them `startingMileage` and `endingMileage`. You need three numbers that can hold decimal places. Make them `doubles` and call them `milesTraveled`, `reimburseRate`, and `amountOwed`. Set the value for `reimburseRate` to `.39`.

3 Make your calculator work.

Add code in the `button1_Click()` method to:

- ★ Make sure that the number in the Starting Mileage field is smaller than the number in the Ending Mileage field. If not, show a message box that says "The starting mileage must be less than the ending mileage". Make the title for the message box "Cannot Calculate".
- ★ Subtract the starting number from the ending number and then multiply it by the reimburse rate using these lines:

```
milesTraveled = endingMileage - startingMileage;
amountOwed = milesTraveled * reimburseRate;
label4.Text = "$" + amountOwed;
```

4 Run it.

Make sure it's giving the right numbers. Try changing the starting value to be higher than the ending value and make sure it's giving you the message box.



Exercise Solution

You were asked to create a reimbursement calculator for a business trip. Here's the code for the first part of the exercise.

```
public partial class Form1 : Form
{
    int startingMileage;
    int endingMileage;
    double milesTraveled;
    double reimburseRate = .39;
    double amountOwed;
    public Form1() {
        InitializeComponent();
    }
    private void button1_Click(object sender, EventArgs e) {
        startingMileage = (int) numericUpDown1.Value;
        endingMileage = (int)numericUpDown2.Value;
        if (startingMileage <= endingMileage) {
            milesTraveled = endingMileage - startingMileage;
            amountOwed = milesTraveled * reimburseRate;
            label4.Text = "$" + amountOwed;
        } else {
            MessageBox.Show(
                "The starting mileage must be less than the ending mileage",
                "Cannot Calculate Mileage");
        }
    }
}
```

int works great for whole numbers. This number could go all the way up to 999,999. So a short or a byte won't cut it.

Did you remember that you have to change the decimal value from the numericUpDown control to an int?

This block is supposed to figure out how many miles were traveled and then multiply them by the reimbursement rate.

We used an alternate way of calling the MessageBox.Show() method here. We gave it two parameters: the first one is the message to display, and the second one goes in the title bar.

This button seems to work, but it has a pretty big problem. Can you spot it?

1 Now add another button to the form.

Make it so that the number of miles traveled is displayed on the form after you've calculated the amount owed.

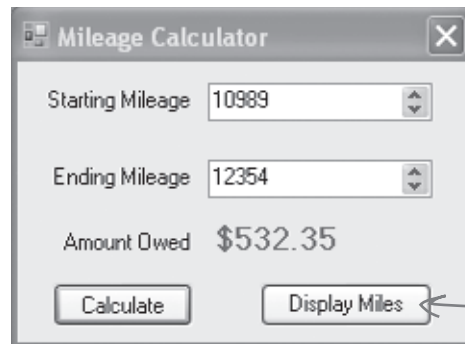

When you're done with the Form, double-click on the Display Miles button to add some code to the project.

2 One line should do it.

All we need to do is get the form to display the `milesTraveled` variable, right? So this line should do that:

```
private void button2_Click(object sender, EventArgs e) {
    MessageBox.Show(milesTraveled + " miles", "Miles Traveled");
}
```

3 Run it.

Type in some values and see what happens.

4 Um, something's not right...

The number of miles always matches the amount owed. Why?

Combining = with an operator

Take a good look at the operator we used to subtract ending mileage from starting mileage (-=). The problem is it doesn't just subtract, it also assigns a value to the variable on the left side of the subtraction sign. The same thing happens in the line where we multiply number of miles traveled by the reimbursement rate. We should replace the -= and the *= with just - and *:

```
private void button1_Click(object sender, EventArgs e)
{
    startingMileage = (int) numericUpDown1.Value;
    endingMileage = (int)numericUpDown2.Value;
    if (startingMileage <= endingMileage){
        milesTraveled = endingMileage -= startingMileage;
        amountOwed = milesTraveled *= reimburseRate;
        label4.Text = "$" + amountOwed;
    } else {
        MessageBox.Show("The starting mileage number must
            be less than the ending mileage number",
            "Cannot Calculate Mileage");
    }
}
```

These are called **compound operators**. This one subtracts startingMileage from endingMileage but also assigns the new value to endingMileage and milesTraveled at the same time.

This is better—now your code won't modify endingMileage and milesTraveled.

```
milesTraveled = endingMileage - startingMileage;
amountOwed = milesTraveled * reimburseRate;
```

So can good variable names help you out here? Definitely! Take a close look at what each variable is supposed to do. You already get a lot of clues from the name `milesTraveled`—you know that's the variable that the form is displaying incorrectly, and you've got a good idea of how that value ought to be calculated. So you can take advantage of that when you're looking through your code to try to track down the bug. It'd be a whole lot harder to find the problem if the incorrect lines looked like this instead:

```
mT = eM -= sM;
aO = mT *= rR;
```

Variables named like this are essentially useless in telling you what their purpose might be.

Objects use variables, too

So far, we've looked at objects separate from other types. But an object is just another data type. Your code treats objects exactly like it treats numbers, strings, and booleans. It uses variables to work with them:

Using an int

- ① Write a statement to declare the integer.

```
int myInt;
```

- ② Assign a value to the new variable.

```
myInt = 3761;
```

- ③ Use the integer in your code.

```
while (i < myInt) {
```

Using an object

- ① Write a statement to declare the object.

```
Dog spot;
```

When you have a class like Dog, you use it as the type in a variable declaration statement.

- ② Assign a value to the object.

```
spot = new Dog();
```

- ③ Check one of the object's fields.

```
while (spot.Happy) {
```

So it doesn't matter if I'm working with an object or a value. If it's going into memory, and my program needs to use it, I use a variable.



Objects are just one more type of variable your program can use.

If your program needs to work with a whole number that's really big, use a long. If it needs a whole number that's small, use a short. If it needs a yes/no value, use a boolean. And if it needs something that barks and sits, use a Dog. No matter what type of data your program needs to work with, it'll use a variable.

Refer to your objects with reference variables

When you create a new object, you use code like `new Guy`. But that's not enough; even though that code creates a new `Guy` object on the heap, it doesn't give you a way to *access* that object. **You need a reference to the object.** So you create a **reference variable**: a variable of type `Guy` with a name, like `Joe`. So `Joe` is a reference to the new `Guy` object you created. Anytime you want to use that particular guy, you can reference it with the reference variable called `Joe`.

That's called
instantiating
the object.

So when you have a variable that is an object type, it's a reference variable: a reference to a particular object. Take a look:

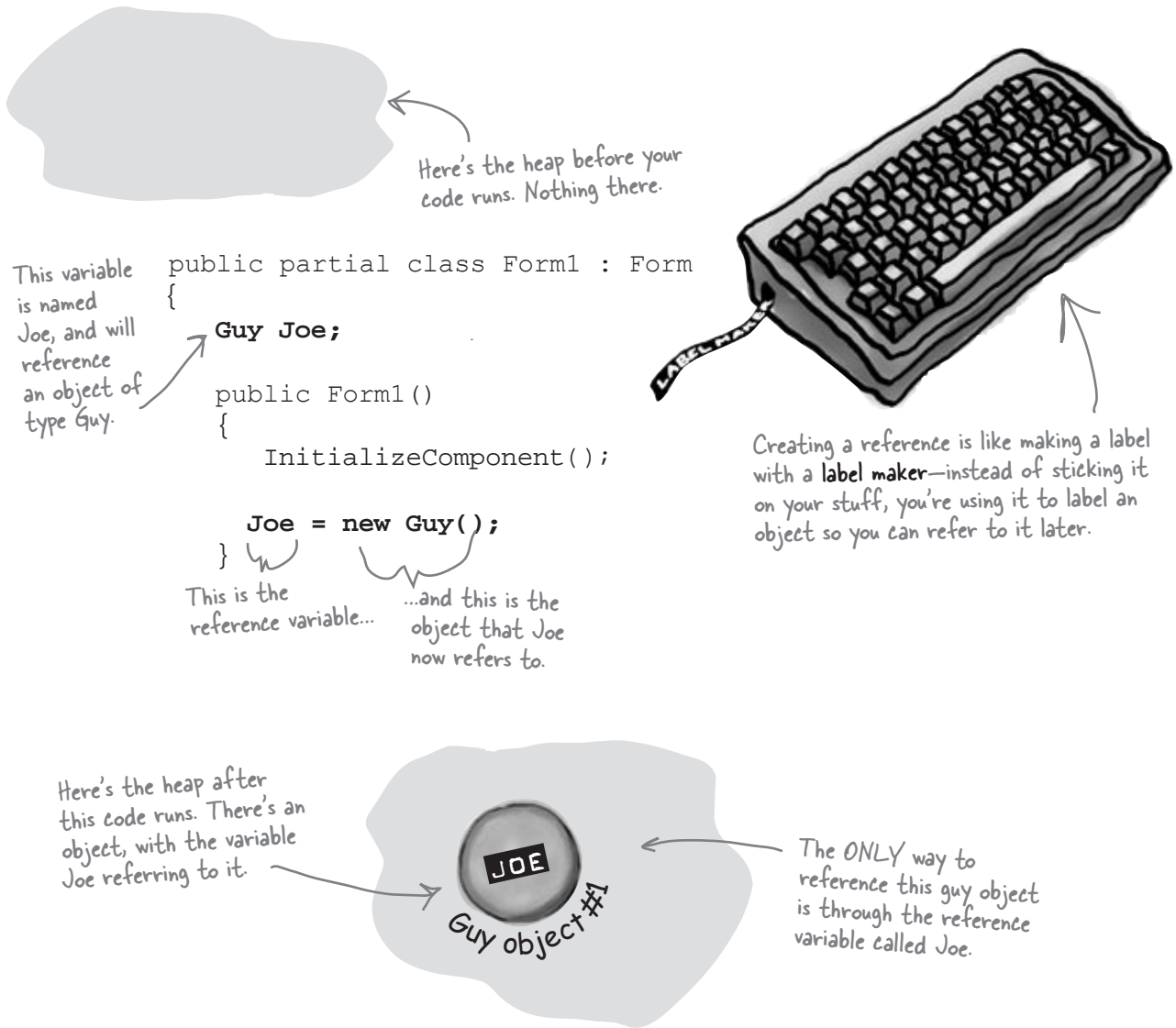

References are like labels for your object

In your kitchen, you probably have a container of salt and sugar. If you switched their labels, it would make for a pretty disgusting meal—even though the labels changed, the contents of the containers stayed the same.

References are like labels. You can move labels around, point them at different things, but it's the **object** that dictates what methods and data are available, not the reference itself.

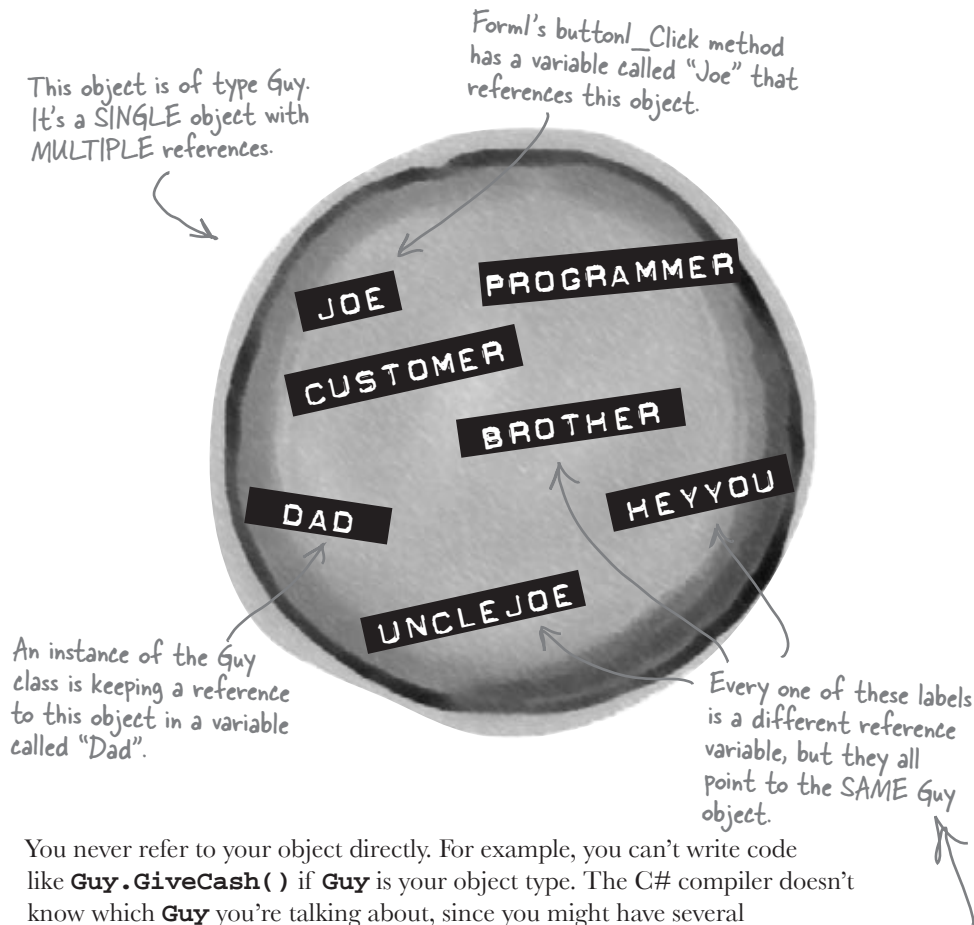

When your code needs to work with an object in memory, it uses a reference, which is a variable whose type is a class of the object it's going to point to. A reference is like a label that your code uses to talk about a specific object.

There are lots of different references to this same Guy, because a lot of different methods use him for different things. Each reference has a different name that makes sense in its context.

You never refer to your object directly. For example, you can't write code like `Guy.GiveCash()` if `Guy` is your object type. The C# compiler doesn't know which `Guy` you're talking about, since you might have several instances of `Guy` on the heap. So you need a reference variable, like `joe`, that you assign to a specific instance, like `Guy joe = new Guy()`.

Now, you can call methods, like `joe.GiveCash()`. `joe` refers to a specific instance of the `Guy` class, and your C# compiler knows exactly which instance to use. And, as you saw above, you might have **multiple labels pointing to the same instance**. So you could say `Guy dad = joe`, and then call `dad.GiveCash()`. That's okay, too—that's what Joe's kid does every day.

If there aren't any more references, your object gets garbage collected

If all of the labels come off of an object, no programs can access that object anymore. That means C# can mark the object for **garbage collection**. That's when C# gets rid of any unreferenced objects, and reclaims the memory those objects took up for your program's use.

For an object to stay in the heap, it has to be referenced. When the last reference to the object disappears, so does the object.

1 Here's some code that creates an object.

```
Guy joe = new Guy()  
{ Name = "Joe", Cash = 50 };
```

When you use the "new" statement, you're telling C# to create an object. When you take a reference variable like "joe" and assign it to that object, it's like you're slapping a new label on it.

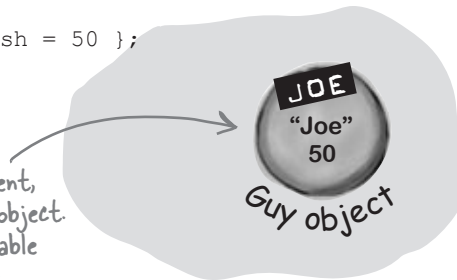

2 Now let's create a second object.

```
Guy bob = new Guy()  
{ Name = "Bob", Cash = 75 };
```

Now we have two Guy object instances, and two reference variables: one for each Guy.

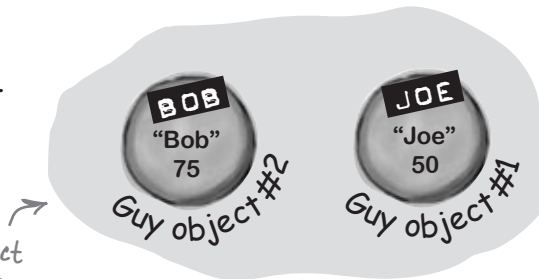

3 Let's take the reference to the first object, and change it to point at the second object.

```
joe = bob;
```

Now joe is pointing to the same object as bob.

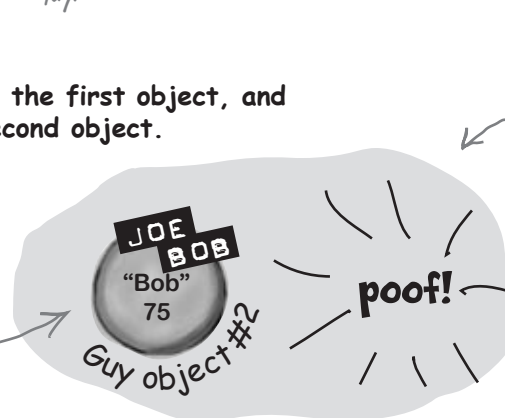

But there is no longer a reference to the first Guy object...

...so C# marks the object for garbage collection, and trashes it. It's gone!



Typecross

Take a break, and sit back and give your right brain something to do. It's your standard crossword; all of the solution words are from this chapter.

When you're done, turn the page, and take on the rest of the chapter.

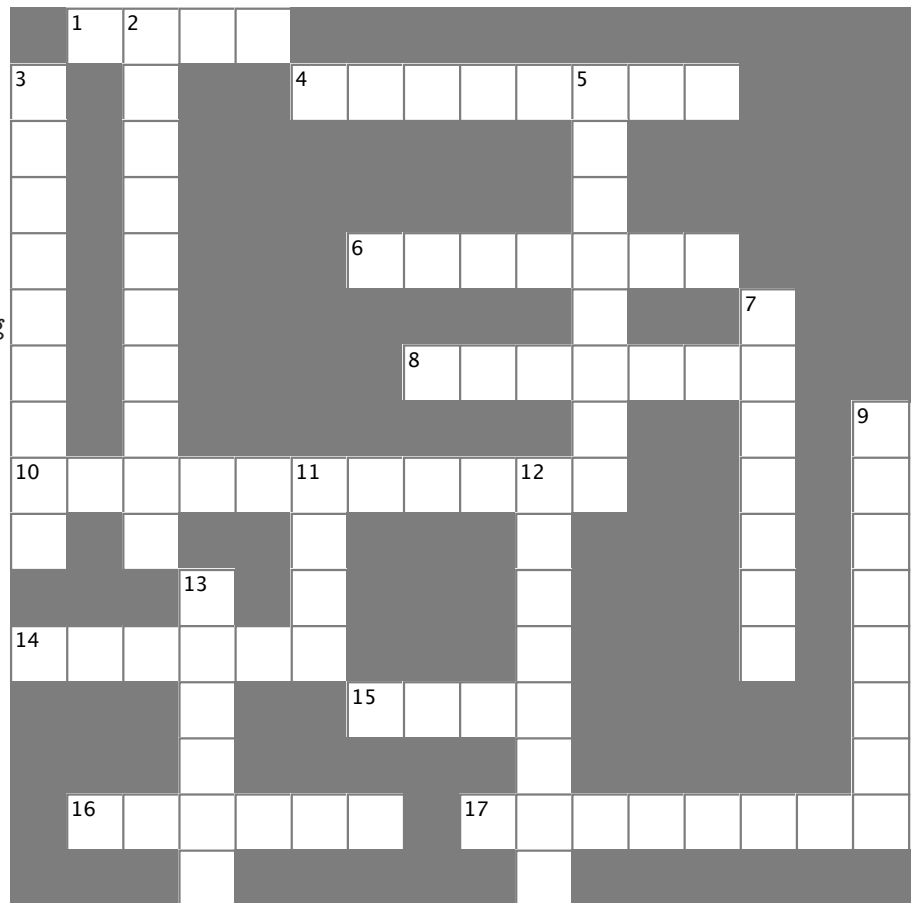

Across

1. The second part of a variable declaration
4. "namespace", "for", "while", "using" and "new" are examples of _____ words.
6. What (int) does in this line of code: `x = (int) y;`
8. When an object no longer has any references pointing to it, it's removed from the heap using _____ collection.
10. What you're doing when you use the + operator to stick two strings together.
14. The type that holds the biggest numbers.
15. The type that stores a single letter or number
16. `\n` and `\r` are _____ sequences
17. The four whole number types that only hold positive numbers

Down

2. You can combine the variable declaration and the _____ into one statement.
3. A variable that points to an object
5. What your program uses to work with data that's in memory
7. If you want to store a currency value, use this type
9. += and -= are this kind of operator
11. A variable declaration always starts with this.
12. Every object has this method that converts it to a string.
13. When you've got a variable of this type, you can assign any value to it

—————> **Answers on page 162.**

Multiple references and their side effects

You've got to be careful when you start moving around reference variables. Lots of times, it might seem like you're simply pointing a variable to a different object. But, you could end up removing all references to another object in the process. That's not a bad thing, but it may not be what you intended. Take a look:

1 `Dog rover = new Dog();`
`rover.Breed = "Greyhound";`

Objects: 1

References: 1

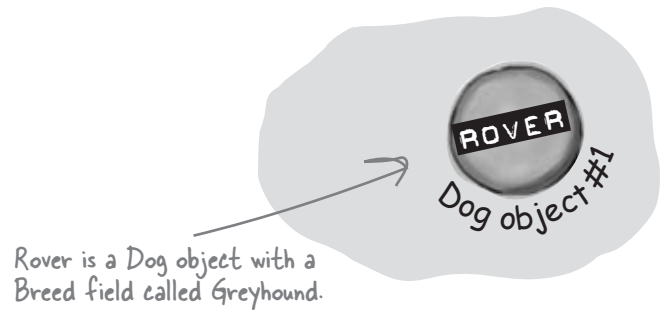

2 `Dog fido = new Dog();`
`fido.Breed = "Beagle";`
`Dog spot = rover;`

Objects: 2

References: 3

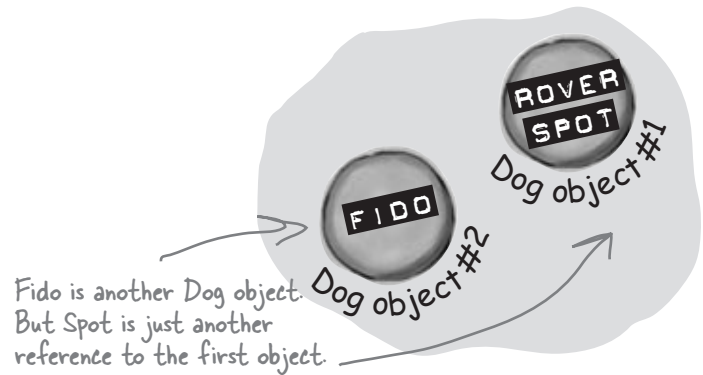

3 `Dog lucky = new Dog();`
`lucky.Breed = "Dachshund";`
`fido = rover;`

Objects: 2

References: 4

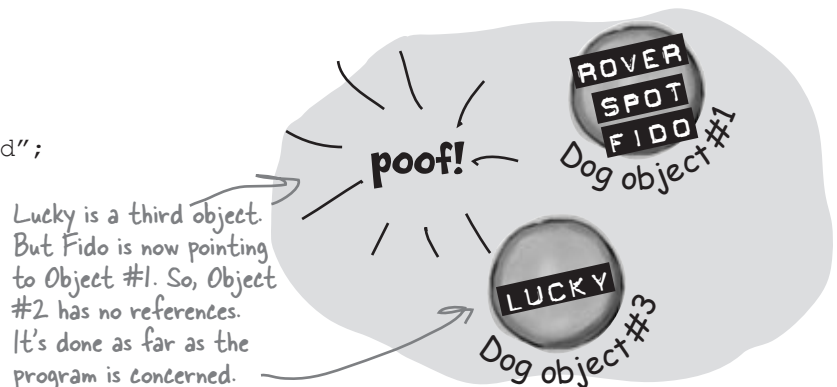



Now it's your turn. Here's one long block of code. Figure out how many objects and references there are at each stage. On the right-hand side, draw a picture of the objects and labels in the heap.

1 `Dog rover = new Dog();`
`rover.Breed = "Greyhound";`
`Dog rinTinTin = new Dog();`
`Dog fido = new Dog();`
`Dog quentin = fido;`

Objects: _____

References: _____

2 `Dog spot = new Dog();`
`spot.Breed = "Dachshund";`
`spot = rover;`

Objects: _____

References: _____

3 `Dog lucky = new Dog();`
`lucky.Breed = "Beagle";`
`Dog charlie = fido;`
`fido = rover;`

Objects: _____

References: _____

4 `rinTinTin = lucky;`
`Dog laverne = new Dog();`
`laverne.Breed = "pug";`

Objects: _____

References: _____

5 `charlie = laverne;`
`lucky = rinTinTin;`

Objects: _____

References: _____

Sharpen your pencil Solution

Now it's your turn. Here's one long block of code. Figure out how many objects and references there are at each stage. On the right-hand side, draw a picture of the objects and labels in the heap.

```
1 Dog rover = new Dog();
  rover.Breed = "Greyhound";
  Dog rinTinTin = new Dog();
  Dog fido = new Dog();
  Dog quentin = fido;
```

Objects: 3

References: 4

One new Dog object is created but Spot is the only reference to it. When Spot is set = to Rover, that object goes away.

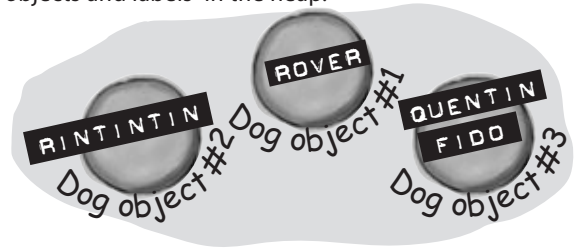

```
2 Dog spot = new Dog();
  spot.Breed = "Dachshund";
  spot = rover;
```

Objects: 3

References: 5

Here a new Dog object is created, but when Fido is set to Rover, Fido's object from #1 goes away.

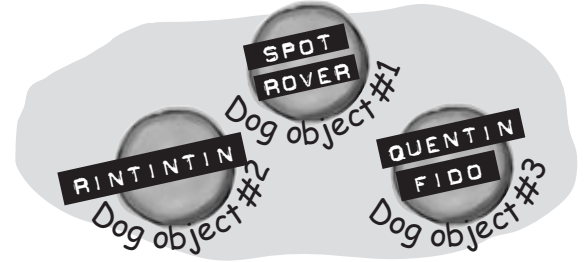

```
3 Dog lucky = new Dog();
  lucky.Breed = "Beagle";
  Dog charlie = fido;
  fido = rover;
```

Objects: 4

References: 7

Charlie was set to Fido when Fido was still on object #3. Then, after that, Fido moved to object #1, leaving Charlie behind.

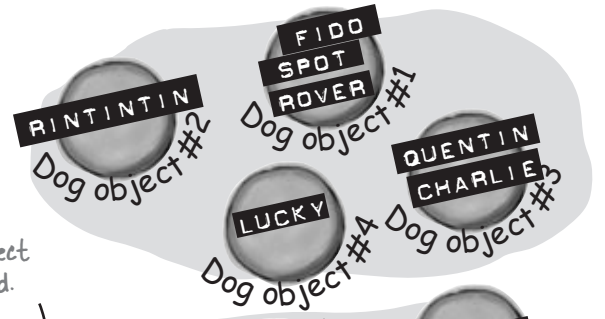

```
4 rinTinTin = lucky;
  Dog laverne = new Dog();
  laverne.Breed = "pug";
```

Objects: 4

References: 8

Dog #2 lost its last reference, and it went away.

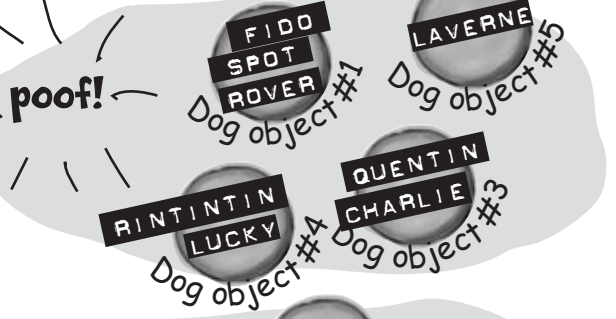

When Rin Tin Tin moved to Lucky's object, the old Rin Tin Tin object disappeared.

```
5 charlie = laverne;
  lucky = rinTinTin;
```

Objects: 4

References: 8

Here the references move around but no new objects are created. And setting Lucky to Rin Tin Tin did nothing because they already pointed to the same object.

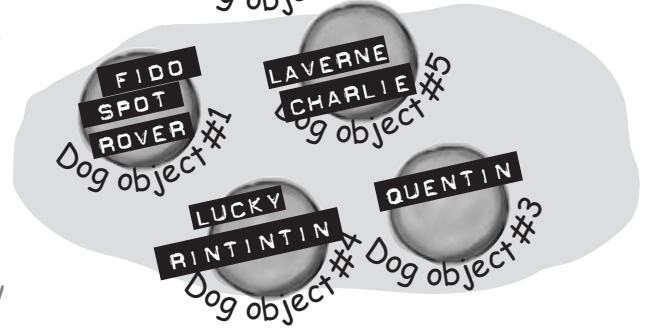



Exercise

Create a program with an elephant class. Make two elephant instances and then swap the reference values that point to them, *without* getting any Elephant instances garbage-collected.

1 Start with a new Windows Application project.

Make the form look like this:



Clicking on the "Lucinda" button calls `lucinda.WhoAmI()`, which displays this message box.

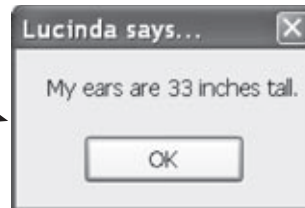

Here's the class diagram for the Elephant class you need to create.

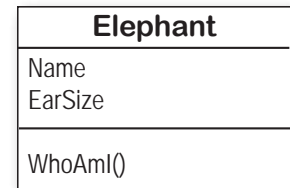

The `WhoAmI()` method should pop up this message box. Make sure the message includes the ear size and the title bar includes the name.

2 Create the Elephant class.

Add an `Elephant` class to the project. Have a look at the `Elephant` class diagram—you'll need an `int` field called `EarSize` and a `String` field called `Name`. (Make sure both are public.) Then add a method called `WhoAmI()` that displays a message box that tells you the name and ear size of the elephant.

3 Create two elephant instances and a reference.

Add two `Elephant` fields to the `Form1` class (in the area right below the class declaration) named `Lloyd` and `Lucinda`. Initialize them so they have the right name and ear size. Here are the `Elephant` object initializers to add to your form:

```
lucinda = new Elephant() { Name = "Lucinda", EarSize = 33 };
lloyd = new Elephant() { Name = "Lloyd", EarSize = 40 };
```

4 Make the "Lloyd" and "Lucinda" buttons work.

Have the `Lloyd` button call `lloyd.WhoAmI()` and the `Lucinda` button call `lucinda.WhoAmI()`.

5 Hook up the swap button.

Here's the hard part. Make the `Swap` button *exchange* the two references, so that when you click `Swap`, the `Lloyd` and `Lucinda` variables swap objects and a "Objects swapped" box is displayed. Test out your program by clicking the `Swap` button and then clicking the other two buttons. The first time you click `Swap`, the `Lloyd` button should pop up `Lucinda`'s message box, and the `Lucinda` button should pop up `Lloyd`'s message box. If you click the `Swap` button again, everything should go back.

C# garbage collects any object with no references to it. So here's your hint: If you want to pour a glass of beer into another glass that's currently full of water, you'll need a third glass to pour the water into...



Exercise Solution

Create a program with an elephant class. Make two elephant instances and then swap the reference values that point to them, *without* getting any Elephant instances garbage-collected.

```
using System.Windows.Forms;

class Elephant {

    public int EarSize;
    public String Name;

    public void WhoAmI() {
        MessageBox.Show("My ears are " + EarSize + " inches tall.",
            Name + " says...");
    }
}
```

This is the Elephant class definition code in the Elephant.cs file we added to the project. Don't forget the "using System.Windows.Forms;" line at the top of the class. Without it, the MessageBox statement won't work.

Here's the Form1 class code from Form1.cs.

```
public partial class Form1 : Form {

    Elephant lucinda;
    Elephant lloyd;

    public Form1()
    {
        InitializeComponent();
        lucinda = new Elephant()
            { Name = "Lucinda", EarSize = 33 };
        lloyd = new Elephant()
            { Name = "Lloyd", EarSize = 40 };
    }

    private void button1_Click(object sender, EventArgs e) {
        lloyd.WhoAmI();
    }

    private void button2_Click(object sender, EventArgs e) {
        lucinda.WhoAmI();
    }

    private void button3_Click(object sender, EventArgs e) {
        Elephant holder;
        holder = lloyd;
        lloyd = lucinda;
        lucinda = holder;
        MessageBox.Show("Objects swapped");
    }
}
```

If you just point Lloyd to Lucinda, there won't be any more references pointing to Lloyd and his object will be lost. That's why you need to have the Holder reference hold onto the Lloyd object until Lucinda can get there.

There's no new statement for the reference because we don't want to create another instance of Elephant.

strings and arrays are different from all of the other data types you've seen, because they're the only ones without a set size (think about that for a bit).



Why do you think we didn't add a Swap() method to the Elephant class?

Two references means TWO ways to change an object's data

Besides losing all the references to an object, when you have multiple references to an object, you can unintentionally change an object. In other words, one reference to an object may **change** that object, while another reference to that object has **no idea** that something has changed. Watch:

- 1 Add another button to your form.

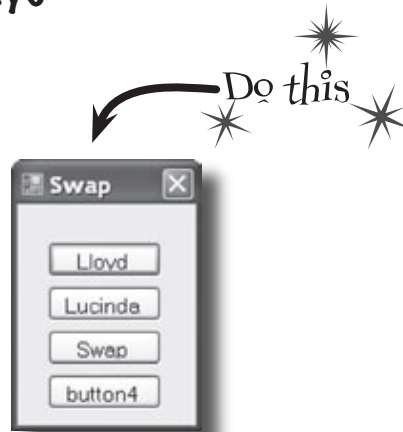

- 2 Add this code for the button. Can you guess what's going to happen when you click it?

```
private void button4_Click(object sender, EventArgs e)
{
    lloyd = lucinda;
    lloyd.EarSize = 4321;
    lloyd.WhoAmI();
}
```

This statement says to set EarSize to 4321 on whatever object the lloyd reference happens to point to.

You're calling the WhoAmI() method from the lloyd object.

But lloyd points at the same thing that lucinda does.

After this code runs, both the lloyd and lucinda variables reference the SAME Elephant object.



- 3 OK, go ahead and click the new button. Wait a second, that's the Lucinda messagebox. Didn't we call the WhoAmI() method from Lloyd?

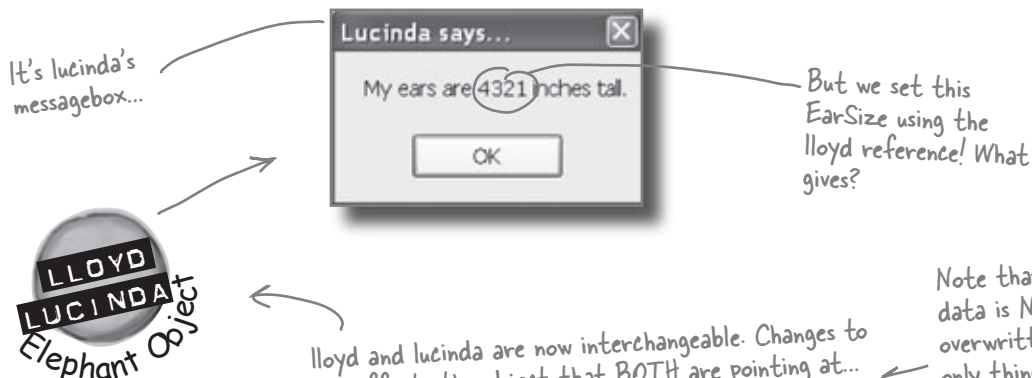

It's lucinda's messagebox...

But we set this EarSize using the lloyd reference! What gives?

lloyd and lucinda are now interchangeable. Changes to one affects the object that BOTH are pointing at... there's no longer a real difference between lloyd and lucinda, since they point to the SAME object.

Note that the data is NOT being overwritten—the only things changing are the references.

A special case: arrays

If you have to keep track of a lot of data of the same type, like a list of heights or a group of dogs, you can do it in an **array**. What makes an array special is that it's a **group of variables** that's treated as one object. An array gives you a way of storing and changing more than one piece of data without having to keep track of each variable individually. When you create an array, you declare it just like any other variable, with a name and a type:

You could combine the declaration of the myArray variable with its initialization—just like any other variable. Then it'd look like this:

You declare an array by specifying its type, followed by square brackets.

You use the new keyword to create an array because it's an object. So an array variable is a kind of reference variable.

```
bool[] myArray;  
myArray = new bool[15];  
myArray[4] = true;
```

This array has 15 elements within it.

This line sets the value of the fifth element of myArray to true. It's the fifth one because the first is myArray[0], the second is myArray[1], etc.

Use each element in an array like it is a normal variable

When you use an array, first you need to **declare a reference variable** that points to the array. Then you need to **create the array object** using the new statement, specifying how big you want the array to be. Then you can **set the elements** in the array. Here's an example of code that declares and fills up an array—and what's happening on the heap when you do it. The first element in the array has an **index** of zero.

In memory, the array is stored as one chunk of memory, even though there are multiple int variables within it.

The type of each element in the array.

```
int[] heights;           name  
heights = new int[7];  
heights[0] = 68;  
heights[1] = 70;  
heights[2] = 63;  
heights[3] = 60;  
heights[4] = 58;  
heights[5] = 72;  
heights[6] = 74;
```

You reference these by index, but each one works essentially like a normal int variable.

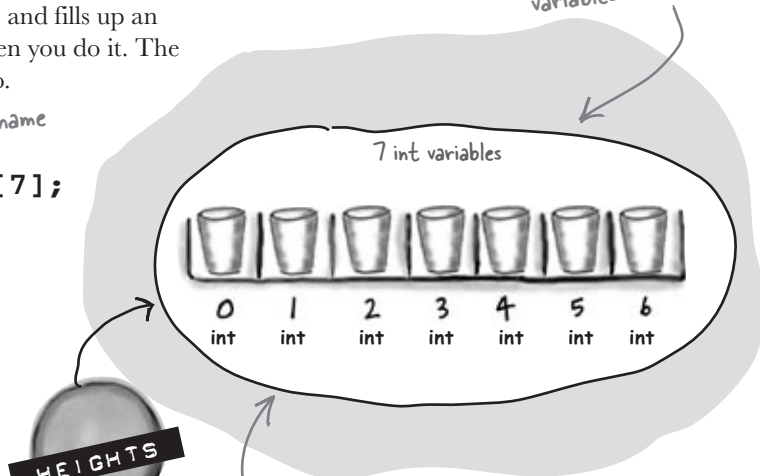

Notice that the array is an object, even though the 7 elements are just value types—like the ones on the first two pages of this chapter.

Arrays can contain a bunch of reference variables, too

You can create an array of object references just like you create an array of numbers or strings. Arrays don't care what the type of variable is that they store; it's up to you. So you can have an array of ints, or an array of Duck objects, with no problem.

Here's code that creates an array of 7 Dog variables. The line that initializes the array only creates reference variables. Since there are only two new Dog () lines, only two actual instances of the Dog class) are created.

```
Dog[] dogs = new Dog[7];
```

```
dogs[5] = new Dog();
```

```
dogs[0] = new Dog();
```

This line declares a dogs variable to hold an array of references to Dog objects, and then creates a 7-element array.

These two lines create new instances of Dog() and put them at indexes 0 and 5.

When you set or retrieve an element from an array, the number inside the brackets is called the index. The first element in the array has an index of zero.

The first line of code only created the array, not the instances. The array is a list of seven Dog reference variables.

An array's length

You can find out how many elements are in an array using its Length property. So if you've got an array called heights, then you can use heights.Length to find out how long it is. If there are 7 elements in the array, that'll give you 7—which means the array elements are numbered 0 to 6.

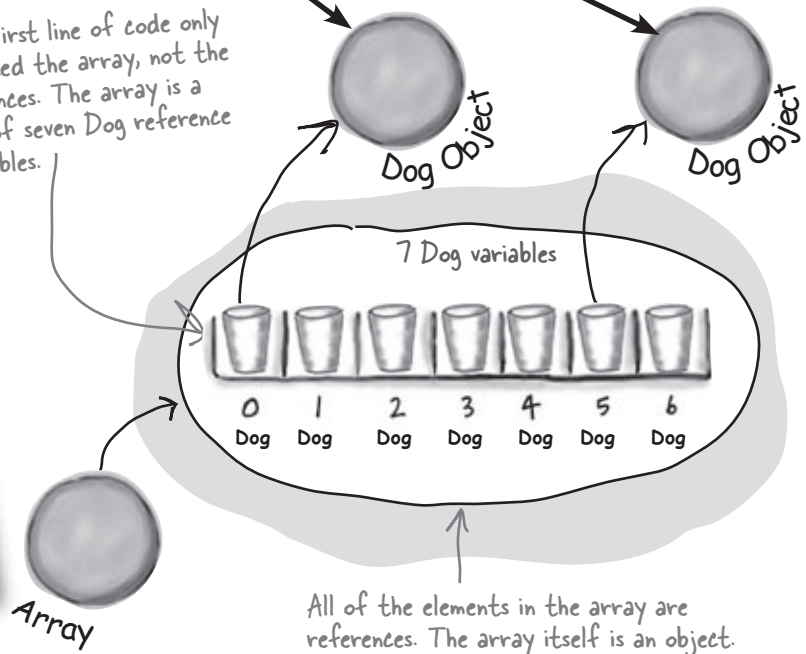

Welcome to Sloppy Joe's Budget House o' Discount Sandwiches!

Sloppy Joe has a pile of meat, a whole lotta bread, and more condiments than you can shake a stick at. But what he doesn't have is a menu! Can you build a program that makes a new *random* menu for him every day?



MenuMaker
Randomizer
Meats
Condiments
Breads
GetMenuItem()

1 Start a new project and add a MenuMaker class

If you need to build a menu, you need ingredients. And arrays would be perfect for those lists. We'll also need some way of choosing random ingredients to combine together into a sandwich. Luckily, the .NET Framework has a built-in class called **Random** that generates random numbers. So we'll have four fields in our class: a **Randomizer** field that holds a reference to a **Random** object, and three arrays of **strings** to hold the meats, condiments, and breads.

The class has three fields to store three different arrays of strings. It'll use them to build the random menu items.

The field called **Randomizer** holds a reference to a **Random** object. Calling its **Next()** method will generate random numbers.

```
public class MenuMaker {
    public Random Randomizer;

    string[] Meats = { "Roast beef", "Salami", "Turkey", "Ham", "Pastrami" };
    string[] Condiments = { "yellow mustard", "brown mustard",
        "honey mustard", "mayo", "relish", "french dressing" };
    string[] Breads = { "rye", "white", "wheat", "pumpernickel",
        "italian bread", "a roll" };
}
```

Remember, use square brackets to access a member of an array. The value of **Breads[2]** is "wheat".

2 Add a GetMenuItem() method to the class that generates a random sandwich

The point of the class is to generate sandwiches, so let's add a method to do exactly that. It'll use the **Random** object's **Next()** method to choose a random meat, condiment and bread from each array. When you pass an **int** parameter to **Next()**, the method returns a random that's less than that parameter. So if your **Random** object is called **Randomizer**, then calling **Randomizer.Next(7)** will return a random number between 0 and 6.

So how do you know what parameter to pass into the **Next()** method? Well, that's easy—just pass in each array's **Length**. That will return the index of a random item in the array.

The **GetMenuItem()** method returns a string that contains a sandwich built from random elements in the three arrays.

```
public string GetMenuItem() {
    string randomMeat = Meats[Randomizer.Next(Meats.Length)];
    string randomCondiment = Condiments[Randomizer.Next(Condiments.Length)];
    string randomBread = Breads[Randomizer.Next(Breads.Length)];
    return randomMeat + " with " + randomCondiment + " on " + randomBread;
}
```

The method puts a random item from the **Meats** array into **randomMeat** by passing **Meats.Length** to the **Random** object's **Next()** method. Since there are 5 items in the **Meats** array, **Meats.Length** is 5, so **Next(5)** will return a random number between 0 and 4.



How it works...

The `randomizer.Next(7)` method gets a random number that's less than 7. `Meats.Length` returns the number of elements in `Meats`. So `randomizer.Next(Meats.Length)` gives you a random number that's greater than or equal to zero, but less than the number of elements in the `Meats` array.

`Meats[Randomizer.Next(Meats.Length)]`

`Meats` is an array of strings. It's got five elements, numbered from zero to 4. So `Meats[0]` equals "Roast Beef", and `Meats[3]` equals "Ham".

I eat **all** my meals at Sloppy Joe's!



3

Build your form

Add six labels to the form, `label11` through `label16`. Then add code to set each label's `Text` property using a `MenuMaker` object. You'll need to initialize the object using a new instance of the `Random` class. Here's the code:

```
public Form1() {
    InitializeComponent();

    MenuMaker menu = new MenuMaker() { Randomizer = new Random() };

    label11.Text = menu.GetMenuItem();
    label12.Text = menu.GetMenuItem();
    label13.Text = menu.GetMenuItem();
    label14.Text = menu.GetMenuItem();
    label15.Text = menu.GetMenuItem();
    label16.Text = menu.GetMenuItem();
}
```

Use an object initializer to set the `MenuMaker` object's `Randomizer` field to a new instance of the `Random` class.

Now you're all set to generate six different random sandwiches using the `GetMenuItem()` method.

When you run the program, the six labels show six different random sandwiches.



Objects use references to talk to each other

So far, you've seen forms talk to objects by using reference variables to call their methods and check their fields. Objects can also call each others' methods using references, too. In fact, there's nothing that a form can do that your objects can't do, because **your form is just another object**. And when objects talk to each other, one useful keyword that they have is **this**. Any time an object uses the `this` keyword, it's referring to itself—it's a reference that points to the object that calls it.

1 Here's a method to tell an elephant to speak

Let's add a method to the Elephant class. Its first parameter is a message from an elephant. Its second parameter is the elephant that said it:

```
public void TellMe(string message, Elephant whoSaidIt) {
    MessageBox.Show(whoSaidIt.Name + " says: " + message);
}
```

Here's what it looks like when it's called:

```
Elephant lloyd = new Elephant() { Name = "Lloyd", EarSize = 40 };
Elephant lucinda = new Elephant() { Name = "Lucinda", EarSize = 33 };
lloyd.TellMe("Hi", lucinda);
```

We called Lloyd's `TellMe()` method, and passed it two parameters: "Hi" and a reference to Lucinda's object. The method uses its `whoSaidIt` parameter to access the `Name` parameter of whatever elephant was passed into `TellMe()` using its second parameter.

2 Here's a method that calls another method

Now let's add this `SpeakTo()` method to the Elephant class. It uses a special keyword: **this**. That's a reference that **lets an object talk about itself**.

```
public void SpeakTo(Elephant talkTo, string message) {
    talkTo.TellMe(message, this);
}
```

This method in the Elephant class calls another elephant's `TalkTo()` method. It lets one elephant communicate with another one.

Let's take a closer look at how this works.

```
lucinda.SpeakTo(lloyd, "Hello");
```

When Lucinda's `SpeakTo()` method is called, it uses its `talkTo` reference parameter to call Lloyd's `TellMe()` method.

```
talkTo.TellMe(message, this);
↓
Lucinda uses talkTo
(which has a reference to
Lloyd) to call TellMe()
↓
lloyd.TellMe(message, [a reference to Lucinda]);
```

this is replaced with a reference to Lucinda's object

So Lloyd acts as if he was called with ("Hello", lucinda), and shows this message:

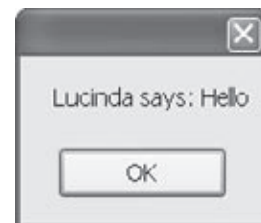

Where no object has gone before

There's another important keyword that you'll use with objects. When you create a new reference and don't set it to anything, it has a value. It starts off set to **null**, which means it's not pointing to anything.

```
Dog fido;
```

```
Dog lucky = new Dog();
```

Right now, there's only one object. The fido reference is set to null.



```
fido = new Dog();
```

Now that fido's pointing to an object, it's no longer equal to null.

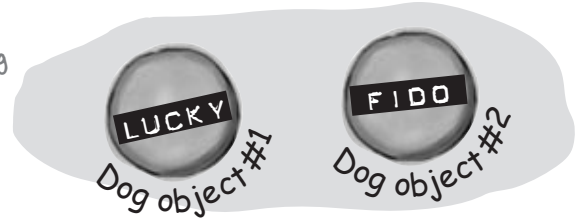

```
lucky = null;
```

When we set lucky to null, it's no longer pointing at its object, so it gets garbage collected.

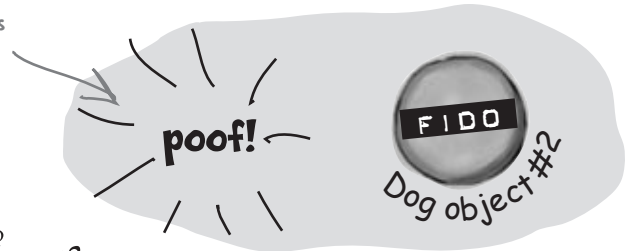

there are no
Dumb Questions

Q: One more time—my form is an object?

A: Yes! That's why your class code starts with a class declaration. Open up code for a form and see for yourself. Then open up Program.cs in any program you've written so far and look inside the Main() method—you'll find "new Form1()".

Q: Why would I ever use **null**?

A: There are a few ways you see null used in typical programs. The most common way is testing for it:

```
if (lloyd == null) {
```

That test will return true if the lloyd reference is set to null.

Another way you'll see the null keyword used is when you *want* your object to get garbage collected. If you've got a reference to an object and you're finished with the object, setting the reference to null will immediately mark it for collection (unless there's another reference to it somewhere.)

Q: You keep talking about garbage collecting, but what's actually doing the collecting?

A: Remember how we talked about the Common Language Runtime (or CLR) back in the beginning of the first chapter? That's the virtual machine that runs all .NET programs. A *virtual machine* is a way for it to isolate running programs from the rest of the operating system. One thing that virtual machines do is manage the memory that they use. That means that it keeps track of all of your objects, figures out when the last reference to the object disappears, and frees up the memory that it was using.

there are no Dumb Questions

Q: I'm still not sure I get how references work.

A: References are the way you use all of the methods and fields in an object. If you create a reference to a Dog object you can then use that reference to access any methods you've created for the Dog object. If you have a (non-static) method called Dog.Bark() or Dog.Beg(), you can create a reference called spot. Then you can use that to access spot.Bark() or spot.Beg(). You could also change information in the fields for the object using the reference. So you could change a Breed field using spot.Breed.

Q: Wait, then doesn't that mean that every time I change a value through a reference I'm changing it for all of the other references to that object too?

A: Yes. If rover is a reference to the same object as spot, changing rover.Breed to "beagle" would make it so that spot.Breed was "beagle."

Q: Go back to that stuff about value types. Now, why can't I change a small number from a bigger type if it's small enough?

A: Okay. The thing about variables is they assign a size to your number no matter how big its value is. So if you name a variable and give it a long type even though the number is really small, (like, say, 5) C# sets aside enough memory for it to get really big. When you think about it, that's really useful. After all, they're called variables because they change all the time.

C# assumes you know what you're doing and you're not going to give a variable a type that you don't need. So even though the number might not be big now, there's a chance that after some math happens, it'll change and C# gives it enough memory to handle whatever type of number you call it.

Q: Remind me again—what does "this." do?

A: `this` is a special variable that you can only use inside an object. When you're inside a class, you use `this` to refer to any field or method of that particular instance. It's especially useful when you're working with a class whose methods call other classes. One object can use it to send a reference to itself to another object. So if Spot calls one of Rover's methods passing `this` as a parameter, he's giving Rover a reference to the Spot object.

Any time you've got code in an object that's going to be instantiated, the instance can use the special `this` variable that has a reference to itself.

BULLET POINTS

There's actually a very specific case where you don't declare a type — you'll learn about it when you use the 'var' keyword in chapter 14.

- When you declare a variable you ALWAYS give a type. Sometimes you combine it with setting the value.
- There are **value types** for numbers that hold different sizes of numbers. The biggest numbers should be of the type, `long` and the smallest ones (up to 255) can be declared as `bytes`.
- Every value type has a size, and you can't put a value of a bigger type into a smaller variable, no matter what the actual size of the data is.
- When you're using literal values, use the F suffix to indicate a float (15.6F) and M for a decimal (36.12M).
- There are a few types (like short to int) that C# knows how to convert automatically. Other than those, the compiler won't let you set a variable equal to a value of a different type unless you cast it."
- There are some words that are reserved by the language and you can't name your variables with them. They're words like, `for`, `while`, `using`, `new`, and others that do specific things in the language.
- References are like labels: you can have as many references to an object as you want, and they all refer to the same thing.
- If an object doesn't have a reference, it gets garbage collected.



Here's an array of Elephant objects and a loop that will go through it and find the one with the biggest ears. What's the value of the biggestEars.Ears **after** each iteration of the for loop?

```
private void button1_Click(object sender, EventArgs e)
```

```
{
```

```
    Elephant[] elephants = new Elephant[7];
```

We're creating an array of 7 Elephant() references.

```
    elephants[0] = new Elephant() { Name = "Lloyd", EarSize = 40 };
```

```
    elephants[1] = new Elephant() { Name = "Lucinda", EarSize = 33 };
```

```
    elephants[2] = new Elephant() { Name = "Larry", EarSize = 42 };
```

```
    elephants[3] = new Elephant() { Name = "Lucille", EarSize = 32 };
```

```
    elephants[4] = new Elephant() { Name = "Lars", EarSize = 44 };
```

```
    elephants[5] = new Elephant() { Name = "Linda", EarSize = 37 };
```

```
    elephants[6] = new Elephant() { Name = "Humphrey", EarSize = 45 };
```

Every array starts with index 0, so the first elephant in the array is Elephants[0].

```
    Elephant biggestEars = elephants[0];
```

Iteration #1 biggestEars.EarSize = _____

```
    for (int i = 1; i < elephants.Length; i++)
```

```
    {
```

```
        if (elephants[i].EarSize > biggestEars.EarSize)
```

Iteration #2 biggestEars.EarSize = _____

```
        {
```

```
            biggestEars = elephants[i];
```

Iteration #3 biggestEars.EarSize = _____

```
        }
```

```
    }
```

This line makes the biggestEars reference point at whatever elephant elephants[i] points to.

```
    MessageBox.Show(biggestEars.EarSize.ToString());
```

Iteration #4 biggestEars.EarSize = _____

```
}
```

Iteration #5 biggestEars.EarSize = _____

Be careful—this loop starts with the second element of the array (at index 1) and iterates six times until i is equal to the length of the array.

Iteration #6 biggestEars.EarSize = _____



Here's an array of Elephant objects and a loop that will go through it and find the one with the biggest ears. What's the value of the biggestEars.Ears **after** each iteration of the for loop?

```
private void button1_Click(object sender, EventArgs e)
{
    Elephant[] elephants = new Elephant[7];
    elephants[0] = new Elephant() { Name = "Lloyd", EarSize = 40 };
    elephants[1] = new Elephant() { Name = "Lucinda", EarSize = 33 };
    elephants[2] = new Elephant() { Name = "Larry", EarSize = 42 };
    elephants[3] = new Elephant() { Name = "Lucille", EarSize = 32 };
    elephants[4] = new Elephant() { Name = "Lars", EarSize = 44 };
    elephants[5] = new Elephant() { Name = "Linda", EarSize = 37 };
    elephants[6] = new Elephant() { Name = "Humphrey", EarSize = 45 };
```

Did you remember that the loop starts with the second element of the array? Why do you think that is?

Iteration #1 biggestEars.EarSize = 40

```
    Elephant biggestEars = elephants[0];
    for (int i = 1; i < elephants.Length; i++)
```

Iteration #2 biggestEars.EarSize = 42

```
    {
        if (elephants[i].EarSize > biggestEars.EarSize)
        {
            biggestEars = elephants[i];
        }
    }
```

The biggestEars reference is used to keep track of which element we've seen while going through the for loop has the biggest ears so far.

Iteration #3 biggestEars.EarSize = 42

```
    MessageBox.Show(biggestEars.EarSize.ToString());
}
```

Iteration #4 biggestEars.EarSize = 44

The for loop starts with the second elephant and compares it to whatever elephant biggestEars points to. If its ears are bigger, it points biggestEars at that elephant instead. Then it moves to the next one, then the next one... by the end of the loop biggestEars points to the one with the biggest ears.

Iteration #5 biggestEars.EarSize = 44

Iteration #6 biggestEars.EarSize = 45



Code Magnets

The code for a button is all scrambled up on the fridge. Can you reconstruct the code snippets to make a working method that produces the output listed below?

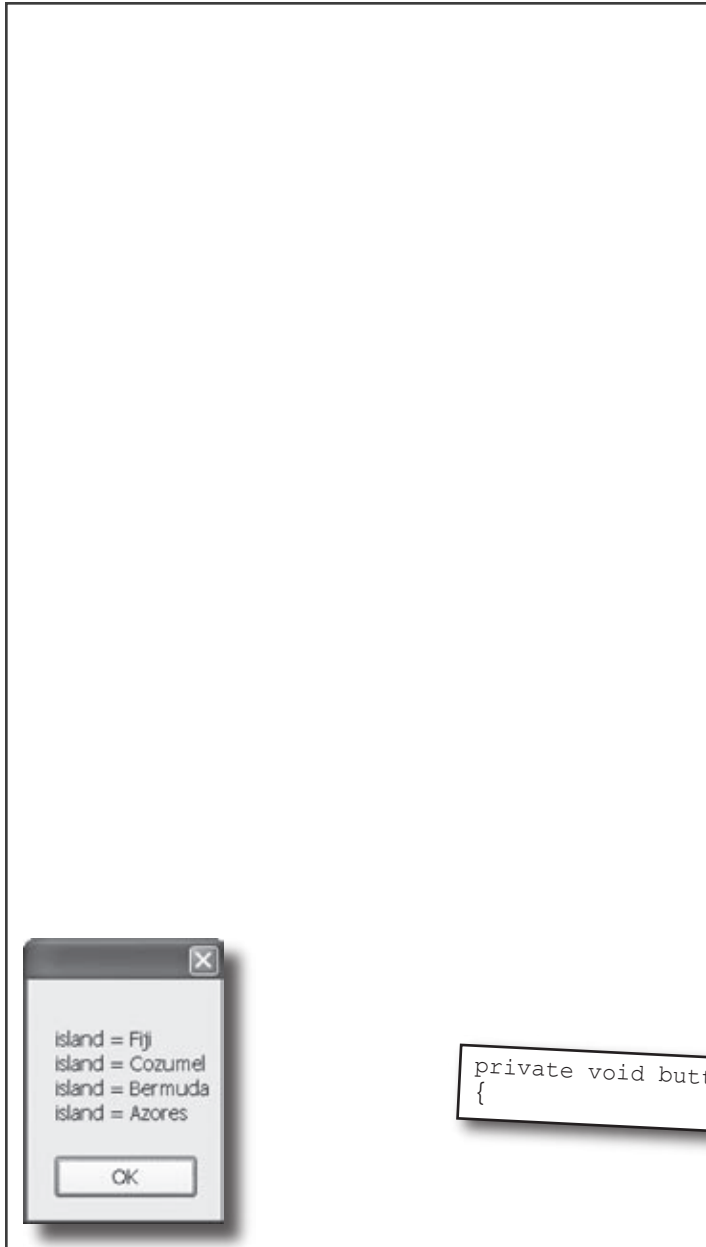

```
int y = 0;
```

```
refNum = index[y];
```

```
islands[0] = "Bermuda";
islands[1] = "Fiji";
islands[2] = "Azores";
islands[3] = "Cozumel";
```

```
int refNum;
while (y < 4) {
```

```
    result += islands[refNum];
```

```
    MessageBox.Show(result);
```

```
    index[0] = 1;
    index[1] = 3;
    index[2] = 0;
    index[3] = 2;
```

```
}
```

```
}
```

```
String[] islands = new String[4];
```

```
    result += "\nisland = ";
```

```
    int[] index = new int[4];
```

```
    y = y + 1;
```

```
private void button1_Click (object sender, EventArgs e)
{
```

```
    String result = "";
```



Code Magnets Solution

The code for a button is all scrambled up on the fridge. Can you reconstruct the code snippets to make a working method that produces the output listed below?

```
private void button1_Click (object sender, EventArgs e)
{
```

```
String result = "";
```

```
int[] index = new int[4];
```

Here's where the index[] array gets initialized.

```
index[0] = 1;
index[1] = 3;
index[2] = 0;
index[3] = 2;
```

```
String[] islands = new String[4];
```

```
islands[0] = "Bermuda";
islands[1] = "Fiji";
islands[2] = "Azores";
islands[3] = "Cozumel";
```

The islands[] array is initialized here.

```
int y = 0;
```

```
int refNum;
while (y < 4) {
```

This while loop pulls a value from the index[] array and uses it for the index in the islands[] array.

```
refNum = index[y];
result += "\nisland = ";
result += islands[refNum];
y = y + 1;
```

The result string is built up using the += operator to concatenate lines onto it.

```
}
```

```
MessageBox.Show(result);
```

```
}
```



Pool Puzzle



Your **job** is to take code snippets from the pool and place them into the blank lines in the code. You **may** use the same snippet more than once, and you won't need to use all the snippets. Your **goal** is to make a class that will compile and run and produce the output listed.

Output

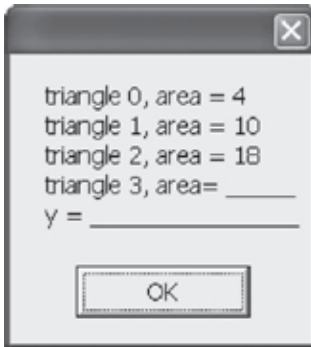

Bonus Question!

For extra bonus points, use snippets from the pool to fill in the two blanks missing from the output.

Note: Each snippet from the pool can be used more than once

	4, t5 area = 18		
area	4, t5 area = 343	int x;	
ta.area	27, t5 area = 18	int y;	x = x + 1; ta.x
x ta.x.area	27, t5 area = 343	int x = 0;	x = x + 2; ta(x)
y ta[x].area		int x = 1;	x = x - 1; ta[x] x < 4
Triangle [] ta = new Triangle(4);	ta[x] = setArea();	int y = x;	28 ta = new Triangle();
Triangle ta = new [] Triangle[4];	ta.x = setArea();	30.0	ta[x] = new Triangle();
Triangle [] ta = new Triangle[4];	ta[x].setArea();		ta.x = new Triangle();

```
class Triangle
{
    double area;
    int height;
    int length;
    public static void Main(String[] args)
    {
        string results = "";
        _____
        _____
        while ( _____ )
        {
            _____
            _____
            _____
            results += "triangle " + x + ", area";
            results += " = " + _____ .area + "\n";
            _____
        }
        _____
        x = 27;
        Triangle t5 = ta[2];
        ta[2].area = 343;
        results += "y = " + y;
        MessageBox.Show(results +
            ", t5 area = " + t5.area);
    }
    void setArea()
    {
        _____ = (height * length) / 2;
    }
}
```

Here's the entry point for the application. Assume it's in a file with the right "using" lines at the top.

Hint: setArea() is NOT a static method. Flip back to Chapter 3 for a refresher on what the static keyword means.

Pool Puzzle Solution



After this line, we've got an array of four Triangle references—but there aren't any Triangle objects yet!

```
class Triangle
{
    double area;
    int height;
    int length;
    public static void Main(String[] args)
    {
        string results = "";
        int x = 0;
        Triangle[] ta = new Triangle[4];
        while ( x < 4 )
        {
            ta[x] = new Triangle();
            ta[x].height = (x + 1) * 2;
            ta[x].length = x + 4;
            ta[x].setArea();
            results += "triangle " + x + ", area";
            results += " = " + ta[x].area + "\n";
            x = x + 1;
        }
        int y = x;
        x = 27;
        Triangle t5 = ta[2];
        ta[2].area = 343;
        results += "y = " + y;
        MessageBox.Show(results +
            "\n, t5 area = " + t5.area);
    }
    void setArea()
    {
        area = (height * length) / 2;
    }
}
```

Notice how this class contains the entry point, but it also creates an instance of itself? That's completely legal in C#.

The while loop creates the four instances of Triangle by calling the new statement four times.

Bonus Answer

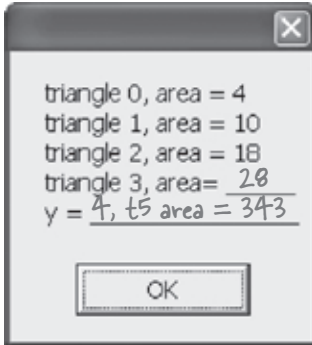

The setArea() method uses the height and length fields to set the area field. Since it's not a static method, it can only be called from inside an instance of Triangle.



There are about 77 **reserved words** in C#. These are words reserved by the C# compiler; you can't use them for variable names. You'll know a lot of them really well by the time you finish the book. Here are some you've already used. Write down what you think these words do in C#.

namespace

Namespaces make sure that the names you are using in your program don't collide with the ones in the .NET Framework or other external classes you've used in your program. All of the classes and methods in a program are inside a namespace.

for

This lets you do a loop that executes three statements. First it declares the variable it's going to use, then there's the statement that evaluates the variable against a condition. The third statement does something to the value.

class

A class is how you define an object. Classes have properties and methods. Properties are what they know and methods are what they do.

public

A public class can be used by every other class in the project. When a variable or method is declared as public, it can be used by classes and called by methods that are outside of the one it's being declared in.

else

Code that starts with else will get executed if the if statement preceding it fails.

new

You use this to create a new instance of an object.

using

This is a way of listing off all of the namespaces you are using in your program. Using lets you use code from the .NET framework and pre-defined classes from third parties as well as classes you can make yourself.

if

One way of setting up a conditional statement in a program. It says if one thing is true, do one thing and if not do something else.

while

while loops are loops that keep on going as long as the condition in them is true.



Typcross Solution

	¹ N	² A	M	E															
³ R		S			⁴ R	E	S	E	R	⁵ V	E	D							
E		S								A									
F		I								R									
E		G			⁶ C	A	S	T	I	N	G								
R		N								A			⁷ D						
E		M				⁸ G	A	R	B	A	G	E							
N		E								L								⁹ C	
¹⁰ C	O	N	C	A	¹¹ T	E	N	A	¹² T	E			I					O	
E		T			Y				O				M					M	
			¹³ O		P				S				A					P	
¹⁴ D	O	U	B	L	E				T				L					O	
			J			¹⁵ C	H	A	R									U	
			E						I									N	
	¹⁶ E	S	C	A	P	E			¹⁷ U	N	S	I	G	N	E	D			
			T						G										

Name:

Date:

C# Lab

A Day at the Races

This lab gives you a spec that describes a program for you to build, using the knowledge you've gained over the last few chapters.

This project is bigger than the ones you've seen so far. So read the whole thing before you get started, and give yourself a little time. And don't worry if you get stuck—there's nothing new in here, so you can move on in the book and come back to the lab later.

We've filled in a few design details for you, and we've made sure you've got all the pieces you need... and nothing else.

It's up to you to finish the job. You can download an executable for this lab from the website... but we won't give you the code for the answer.

The Spec: Build a Racetrack Simulator

Joe, Bob, and Al love going to the track, but they're tired of losing all their money. They need you to build a simulator for them so they can figure out winners *before* they lay their money down. And, if you do a good job, they'll cut you in on their profits.

Here's what you're going to build for them...

The Guys

Joe, Bob, and Al want to bet on a dog race. Joe starts with 50 bucks, Bob starts with 75 bucks, and Al starts with 45 bucks. Before each race, they'll each decide if they want to bet, and how much they want to put down. The guys can change their bets right up to the start of the race... but once the race starts, all bets are final.



The Betting Parlor

The betting parlor keeps track of how much cash each guy has, and what bet he's placed. There's a minimum bet of 5 bucks. The parlor only takes one bet per person for any one race.

The parlor checks to make sure that the guy who's betting has enough cash to cover his bet—so the guys can't place a bet if they don't have the cash to cover the bet.



**Welcome to Curly's
Betting Parlor**
Minimum Bet: \$5
One bet per person per race
Got enough cash?

Betting

Every bet is double-or-nothing—either the winner doubles his money, or he loses what he bet. There's a minimum bet of 5 bucks, and each guy can bet up to 15 bucks on a single dog. If the dog wins, the bettor ends up with twice the amount that he bets (after the race is complete). If he loses, that amount disappears from his pile.

Say a guy places a \$10 bet at the window. At the end of the race, if his dog wins, his cash goes up by \$10 (because he keeps the original \$10 he bet, plus he gets \$10 more from winning). If he loses, his cash goes down by \$10.

All bets: double-or-nothing
Minimum Bet: \$5
Up to \$15 per dog
Win: \$\$ added
Lose: \$\$ removed

The Race

There are four dogs that run on a straight track. The winner of the race is the first dog to cross the finish line. The race is totally random, there are no handicaps or odds, and a dog isn't more likely to win his next race based on his past performance.

If you want to build a handicap system, by all means do it! It'll be really good practice writing some fun code.

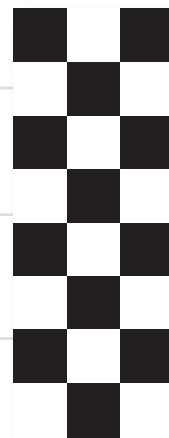

Sound fun? We've got more details coming up...



You'll need three classes and a form

You'll build three main classes in the project, as well as a GUI for the simulator. You should have an array of three Guy objects to keep track of the three guys and their winnings, and an array of four Greyhound objects that actually run the race. Also, each instance of Guy should have its own Bet object that keeps track of his bet and pays out (or takes back) cash at the end of the race.

We've gotten you started with class descriptions and some snippets of code to work from. You've got to finish everything up.

You'll need to add "using System.Windows.Forms" to the top of the Greyhound and Guy classes. And you'll need to add "using System.Drawing;" to Greyhound, because it uses Point.

We've given you the skeleton of the class you need to build. Your job is to fill in the methods.

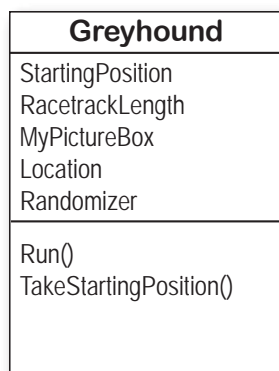

```
public class Greyhound {
    public int StartingPosition; // Where my PictureBox starts
    public int RacetrackLength; // How long the racetrack is
    public PictureBox MyPictureBox = null; // My PictureBox object
    public int Location = 0; // My Location on the racetrack
    public Random Randomizer; // An instance of Random

    public bool Run() {
        // Move forward either 1, 2, 3 or 4 spaces at random
        // Update the position of my PictureBox on the form
        // Return true if I won the race
    }

    public void TakeStartingPosition() {
        // Reset my location to the start line
    }
}
```

You only need one instance of Random—each Greyhound's Randomizer reference should point to the same Random object.

We've added comments to give you an idea of what to do.

Don't overthink this... sometimes you just need to set a variable, and you're done.

See how the class diagram matches up with the code?

The Greyhound object initializer is pretty straightforward. Just make sure you pass a reference to the right PictureBox on the form to each Greyhound object.

Your object can control things on your form...

The Greyhound class keeps track of its position on the racetrack during the race. It also updates the location of the PictureBox representing the dog to move down the race track. Each instance of Greyhound uses a field called MyPictureBox to reference the PictureBox control on the form that shows the picture of the dog. Suppose the distance variable contains the distance to move the dog forward. Then this code will update the location of MyPictureBox by adding distance to its X value:

You'll have to make sure the form passes the right pictureBox into each Greyhound's object initializer.

```
Point p = MyPictureBox.Location;
p.X += distance;
MyPictureBox.Location = p;
```

You get the current location of the picture...
 ...add the value to move forward to its X coordinate...
 ...and then update the picture box location on the form.

A Day at the Races

Guy
Name
MyBet
Cash
MyRadioButton
MyLabel
UpdateLabels()
PlaceBet()
ClearBet()
Collect()

When you initialize the Guy object, make sure you set its MyBet field to null, and call its UpdateLabels() method as soon as it's initialized.

This is the object that Guy uses to represent bets in the application.

Bet
Amount
Dog
Bettor
GetDescription
PayOut

Hint: You'll instantiate Bet in the Guy code. Guy will use the **this** keyword to pass a reference to himself to the Bet's initializer.

```
public class Guy {
    public string Name; // The guy's name
    public Bet MyBet; // An instance of Bet() that has his bet
    public int Cash; // How much cash he has

    // The last two fields are the guy's GUI controls on the form
    public RadioButton MyRadioButton; // My RadioButton
    public Label MyLabel; // My Label

    public void UpdateLabels() {
        // Set my label to my bet's description, and the label on my
        // radio button to show my cash ("Joe has 43 bucks")
    }

    public void ClearBet() {} // Reset my bet so it's zero

    public bool PlaceBet(int Amount, int Dog) {
        // Place a new bet and store it in my bet field
        // Return true if the guy had enough money to bet
    }

    public void Collect(int Winner) {} // Ask my bet to pay out
}
```

Once you set MyLabel to one of the labels on the form, you'll be able to change the label's text using MyLabel.Text. And the same goes for MyRadioButton!

Add your code here.

Remember that bets are represented by instances of Bet.

The key here is to use the Bet object... let it do the work.

The object initializer for Bet just sets the amount, dog and bettor.

```
public class Bet {
    public int Amount; // The amount of cash that was bet
    public int Dog; // The number of the dog the bet is on
    public Guy Bettor; // The guy who placed the bet

    public string GetDescription() {
        // Return a string that says who placed the bet, how much
        // cash was bet, and which dog he bet on ("Joe bets 8 on
        // dog #4"). If the amount is zero, no bet was placed
        // ("Joe hasn't placed a bet").
    }

    public int PayOut(int Winner) {
        // The parameter is the winner of the race. If the dog won,
        // return the amount bet. Otherwise, return the negative of
        // the amount bet.
    }
}
```

This is a common programming task: assembling a string or message from several individual bits of data.

Here's your application architecture

Spend some time looking closely at the architecture. It looks pretty complicated at first, but there's nothing here you don't know. Your job is to recreate this architecture yourself, starting with the `Greyhound` and `Guy` arrays in your main form.

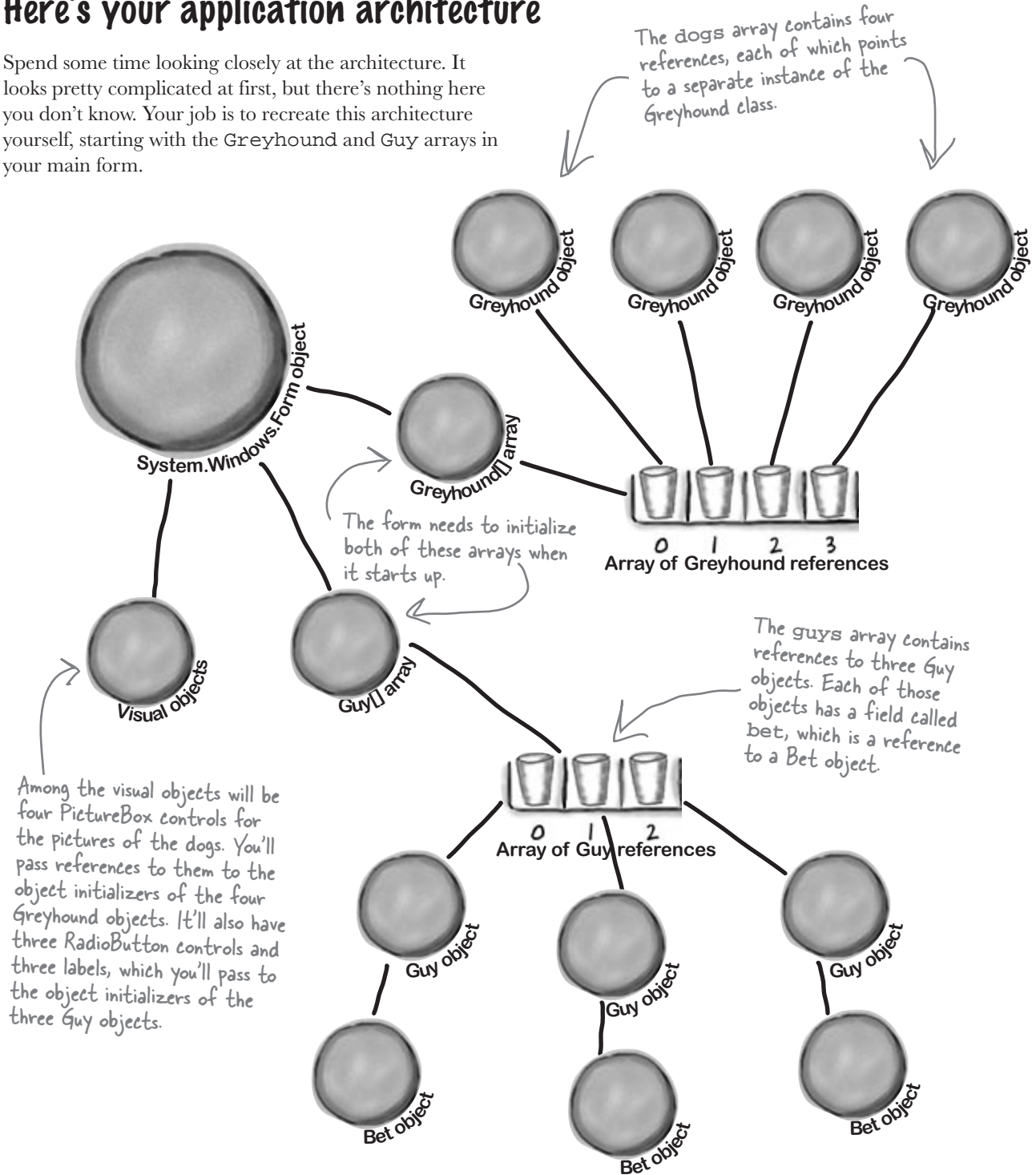

When a Guy places a bet, he creates a new Bet object

First the form tells Guy #2 to place a bet for 7 bucks on dog #3...

```
Guy[1].PlaceBet(7, 3)
```

...so Guy #2 creates a new instance of Bet, using the `this` keyword to tell the Bet object that he's the bettor...

```
MyBet = new Bet()
{ Amount = 7, dog = 3, Bettor = this };
```



...and since the Guy had enough money to place the bet, `PlaceBet()` returns `true`.

The form tells the dogs to keep running until there's a winner

When the user tells the form to start the race, the form starts a loop to animate each dog running along the track.

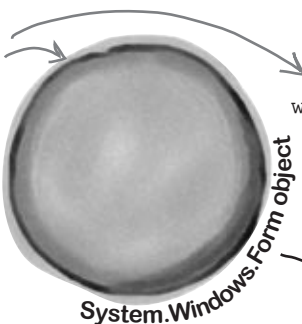

```
while ( there's no winner ) {
  for ( loop through each dog, making sure there's still no winner ) {
    have the dog run one pace
  }
}
```

Each dog's `Run()` method checks to see if that dog won the race, so the loops should end immediately as soon as one of the dog wins.

The Bet object figures out if it should pay out

```
Guy[1].Collect(winningDog)
```

The betting parlor in the form tells each Guy which dog won so he can collect any winnings from his bet.

```
MyBet.Payout(winningDog)
```



The Guy will add the result of `Bet.Payout()` to his cash. So if the dog won, it should return `Amount`; otherwise, it'll return `-Amount`.

```
if ( my dog won ) {
  return Amount;
} else {
  return -Amount;
}
```

Here's what your GUI should look like

The graphical user interface for the “Day at the Races” application consists of a form that’s divided into two sections. The top is the racetrack: a `PictureBox` control for the track, and four more for the dogs. The bottom half of the form shows the betting parlor, where three guys (Joe, Bob, and Al) can bet on the outcome of the race.

Each of the four dogs has its own `PictureBox` control. When you initialize each of the four `Greyhound` objects, each one’s `MyPictureBox` field will have a reference to one of these objects. You’ll pass the reference (along with the racetrack length and starting position) to the `Greyhound`’s object initializer.

You’ll use the `Length` property of the racetrack `PictureBox` control to set the racetrack length in the `Greyhound` object, which it’ll use to figure out if it won the race.

Make sure you set each `PictureBox`’s `SizeMode` property to `Zoom`.

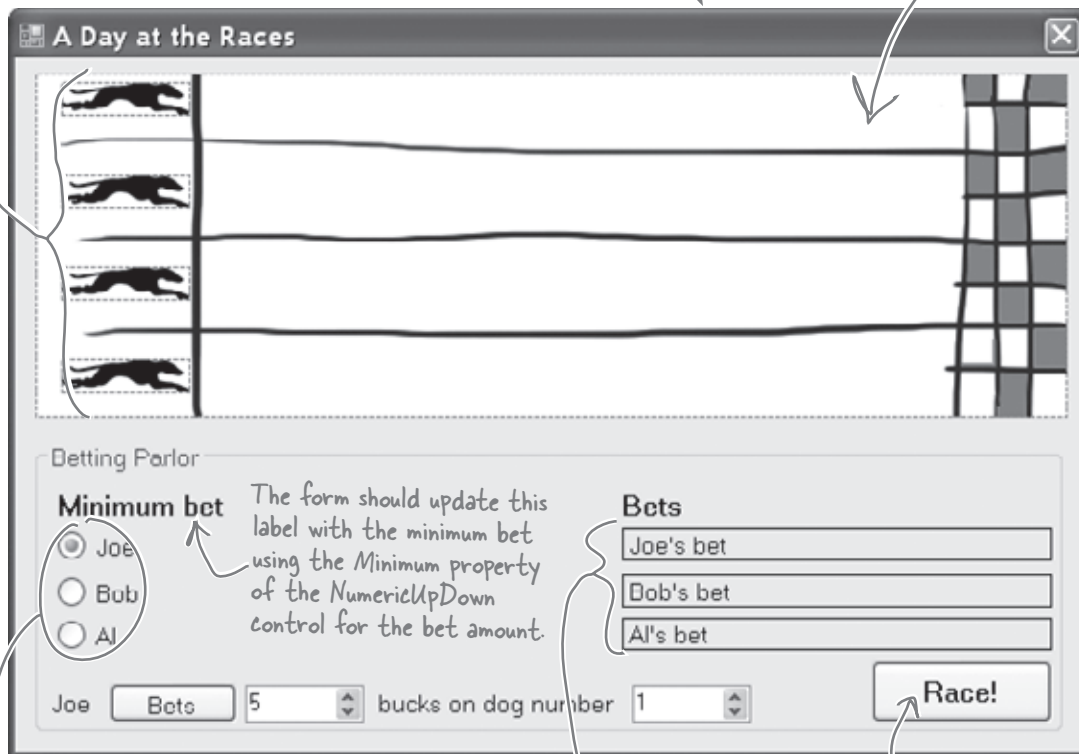

All three guys can bet on the race, but there’s only one betting window so only one guy can place a bet at a time. These radio buttons are used to select which guy places the bet.

When a Guy places a bet, it overwrites any previous bet he placed. The current bets show up in these label controls. Each label has `AutoSize` set to `False` and `BorderStyle` set to `FixedSingle`.

Once all bets are placed, click this button to start the race.

You can download the graphics files from www.headfirstlabs.com/books/hfcssharp/

Placing bets

Use the controls in the Betting Parlor groupbox to place each guy's bet. There are three distinct stages here:

1 No bets have been placed yet

When the program first starts up, or if a race has just finished, no bets have been placed in the betting parlor. You'll see each guy's total cash next to his name on the left.

When a guy places a bet, his Guy object updates this label using the MyLabel reference. He also updates the cash he has using his MyRadioButton reference.

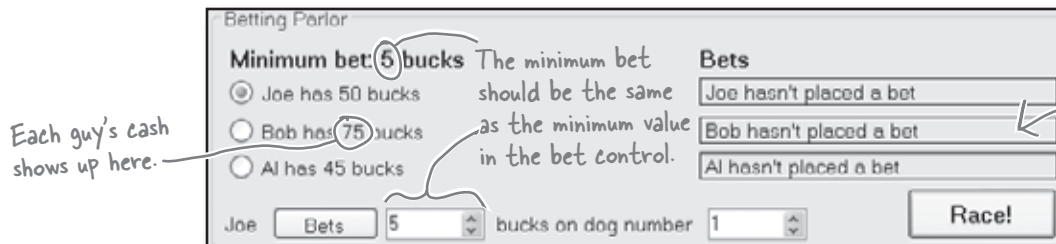

2 Each guy places his bets

To place a bet, select the guy's radio button, select an amount and a dog, and click the Bets button. His PlaceBet () method will update the label and radio button.

Once Bob places his bet, his Guy object updates this label and the radio button text.

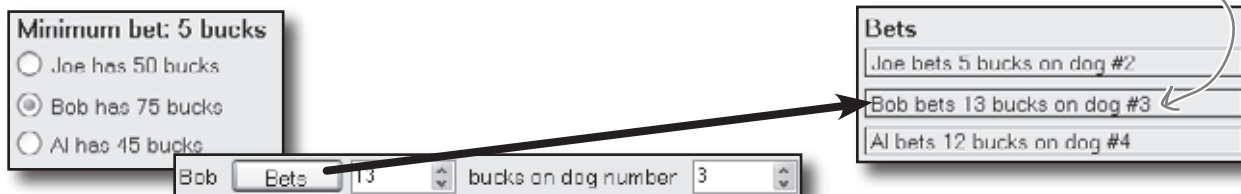

3 After the race, each guy collects his winnings (or pays up!)

Once the race is complete and there's a winner, each Guy object calls his Collect () method and adds his winnings or losses to his cash.

Since Al bet 12 bucks on the winning dog, his cash goes up by 12. The other two guys lose the money they bet.

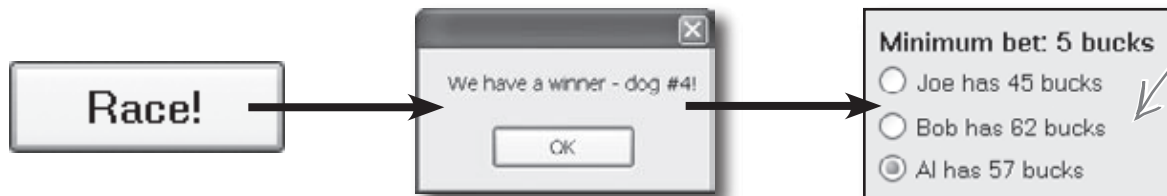

Make sure all the Greyhound objects share one Random object! If each dog creates its own new instance of Random, you might see a bug where all of the dogs generate the same sequence of random numbers.

The Finished Product

You'll know your "Day at the Races" application is done when your guys can place their bets and watch the dogs race.

During the race, the four dog images run across the racetrack until one of them wins the race.

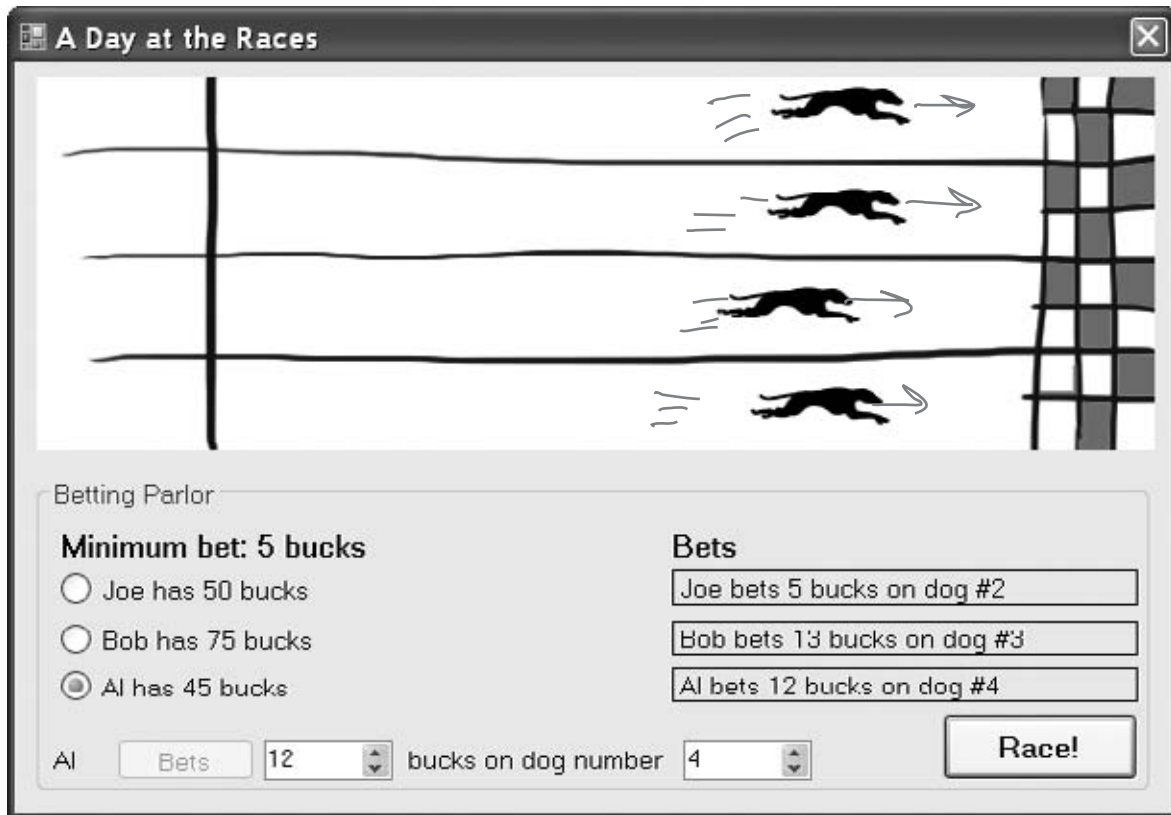

You can download a finished executable, as well as the graphics files for the four dogs and the racetrack, from the Head First labs website:

www.headfirstlabs.com/books/hfcsharp

During the race, no bets can be placed... and make sure you can't start a new race while the dogs are running!

But you won't find the source code! In real life, you don't get a solution to your programming problems. Here's your chance to really test your C# knowledge and see just how much you've learned!

5 encapsulation

Keep your privates...
private



Ever wished for a little more privacy?

Sometimes your objects feel the same way. Just like you don't want anybody you don't trust reading your journal or paging through your bank statements, good objects don't let **other** objects go poking around their fields. In this chapter, you're going to learn about the power of **encapsulation**. You'll **make your object's data private**, and add methods to **protect how that data is accessed**.

Kathleen is an event planner

She's been planning dinner parties for her clients and she's doing really well. But lately she's been having a hard time responding to clients fast enough with an estimate for her services.



Kathleen would rather spend her time planning events, not planning estimates.

When a new client calls Kathleen to do a party, she needs to find out the number of guests, what kind of drinks to serve, and what decorations she should buy. Then she uses a pretty complicated calculation to figure out the total cost, based on a flow chart she's been using for years. The bad news is that it takes her a long time to work through her chart, and while she's estimating, her potential clients are checking out other event planners.

It's up to you to build her a C#-driven event estimator and save her business. Imagine the party she'll throw you when you succeed!

What does the estimator do?

Kathleen runs down some of the basics of her system for figuring out the costs of an event. Here's part of what she came up with:

Kathleen's Party Planning Program—Cost Estimate for a Dinner Party

- For each person on the guest list there's a \$25 food charge.
- Clients have a choice when it comes to drinks. Most parties serve alcohol, which costs \$20 per person. But they can also choose to have a party without alcohol. Kathleen calls that the "Healthy Option," and it only costs \$5 per person to have soda and juice instead of alcohol. Choosing the Healthy Option is a lot easier for her, so she gives the client a 5% discount on the entire party, too.
- There are two options for the cost of decorations. If a client goes with the normal decorations, it's \$7.50 per person with a \$30 decorating fee. A client can also upgrade the party decorations to the "Fancy Option"—that costs \$15 per person with a \$50 one-time decorating fee.

Here's another look at this same set of costs, broken down into a little flow chart to help you see how it works:

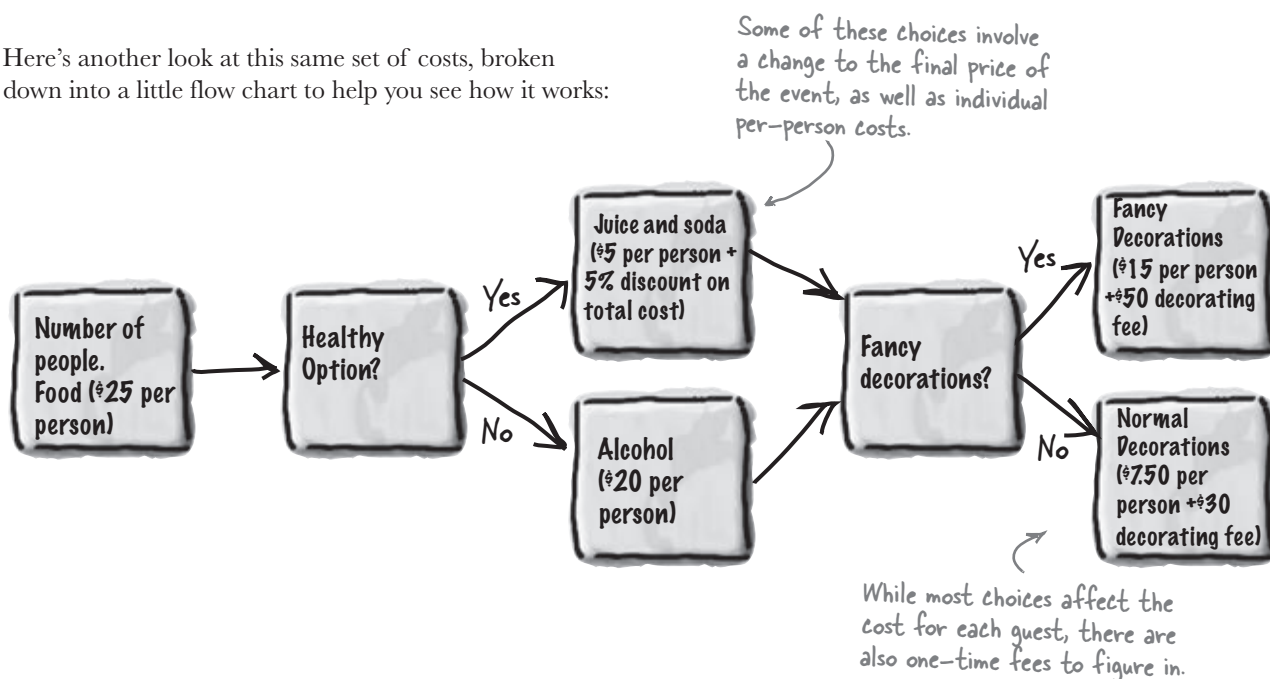



Exercise

Build a program to solve Kathleen's party estimating problem.

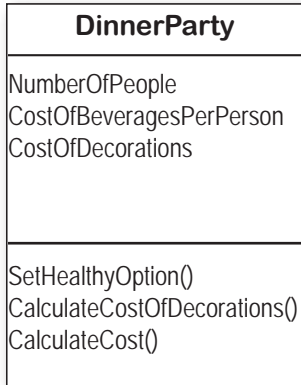

Here's the class diagram for the DinnerParty class you'll need to create.

The SetHealthyOption() method uses a bool parameter (healthyOption) to update the CostOfBeveragesPerPerson field based on whether or not the client wants the healthy option.

You don't need to add "using System.Windows.Forms;" to your DinnerParty class, because it doesn't use MessageBox.Show(), Point, or anything else from that .NET Framework namespace.

1 Create a new Windows Application project and add a class file to it called DinnerParty.cs, and build the DinnerParty class using the class diagram to the left. It's got three methods: CalculateCostOfDecorations(), SetHealthyOption(), and CalculateCost(). For the fields, use decimal for the two costs, int for the number of people, and bool to keep track of whether or not the healthy option was selected. Make sure you **add an M after every literal** you assign to a decimal value (10.0M).

2 Here's a useful C# tool. Since the cost of food won't be changed by the program, you can declare it as a **constant**, which is like a variable except that its value can never be changed. Here's the declaration to use:

```
public const int CostOfFoodPerPerson = 25;
```

3 Flip back to the previous page to be sure you've got all of the logic right for the methods. Only one of them returns a value (a decimal)—the other two are void. The CalculateCostOfDecorations() method figures out the cost of decorations for the number of people attending the party. Use the CalculateCost() method to figure out the total cost by adding up the cost of the decorations to the cost of drinks and food per person. If the client wants the Healthy Option, you can apply the discount inside the CalculateCost() method after you've figured out the total cost.

4 Add this code to your form:

```
DinnerParty dinnerParty;
public Form1() {
    InitializeComponent();
    dinnerParty = new DinnerParty() { NumberOfPeople = 5 };
    dinnerParty.SetHealthyOption(false);
    dinnerParty.CalculateCostOfDecorations(true);
    DisplayDinnerPartyCost();
}
```

You'll declare the dinnerParty field in the form, and then add these four lines below InitializeComponent().

5 Here's what the form should look like. Use the NumericUpDown control's properties to set the maximum number of people to 20, the minimum to 1, and the default to 5. Get rid of the maximize and minimize buttons, too.

Set the default value to 5. The minimum should be 1 and the maximum should be 20.

The Fancy decorations box should have Checked set to true.

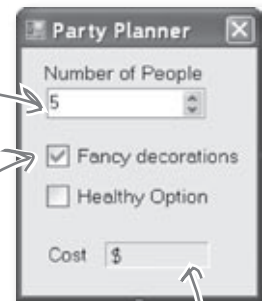

This is just a label with the Text Property set to "", the BorderStyle property set to Fixed3D, and the AutoSize property set to false.

- 6 Instead of using a button to calculate the costs, this form will update the cost label automatically as soon as you use a checkbox or the NumericUpDown control. The first thing you need to do is create a method in the form that displays the cost.

Add this method to Form1 (). It'll get called when the NumericUpDown control is clicked:

```
private void DisplayDinnerPartyCost()
{
    decimal Cost = dinnerParty.CalculateCost (checkBox2.Checked);
    costLabel.Text = Cost.ToString("c");
}
```

This method will get called by all of the other methods you create on the form. It's how you update the cost label with the right value whenever anything changes.

Change the name of the label that displays the cost to costLabel.

Passing "c" to ToString() tells it to format the cost as a currency value. If you're in a country that uses dollars, it'll add a dollar sign.

Add this method to the form—it'll recalculate the cost of the party and put it in the Cost label.

This is true if the checkbox for the Healthy Option is checked.

When you double-click on a button in the IDE to add code that gets run when the button is clicked, that's an event handler too.

- 7 Now hook up the NumericUpDown field to the NumberOfPeople variable you created in the DinnerParty class and display the cost in the form. Double-click on the NumericUpDown control—the IDE will add an **event handler** to your code. That's a method that gets run every time the control is changed. It'll reset the number of people in the party. Fill it in like this:

```
private void numericUpDown1_ValueChanged(
    object sender, EventArgs e)
{
    dinnerParty.NumberOfPeople = (int) numericUpDown1.Value;
    DisplayDinnerPartyCost();
}
```

You need to cast numericUpDown1.Value to an int because it's a Decimal property.

Uh-oh—there's a problem with this code. Can you spot it? Don't worry if you don't see it just yet. We'll dig into it in just a couple of minutes!

The value you send from the form to the method will be fancyBox.Checked. That will be passed as a boolean parameter to the method in the class.

These are just two-line methods. The first line will call the method you created in the class to figure out the costs and the second will display the total cost on the form.

- 8 Double-click on the **Fancy Decorations** checkbox on the form and make sure that it first calls `CalculateCostOfDecorations()`, and then `DisplayDinnerPartyCost()`. Next, double-click the **Healthy Option** checkbox and make sure that it calls the `SetHealthyOption()` method in the DinnerParty class and then calls the `DisplayDinnerPartyCost()` method.



Exercise Solution

Here's the code that goes into DinnerParty.cs.

```
public class DinnerParty {
    const int CostOfFoodPerPerson = 25;
    public int NumberOfPeople;
    public decimal CostOfBeveragesPerPerson;
    public decimal CostOfDecorations = 0;

    public void SetHealthyOption(bool healthyOption) {
        if (healthyOption) {
            CostOfBeveragesPerPerson = 5.00M;
        } else {
            CostOfBeveragesPerPerson = 20.00M;
        }
    }

    public void CalculateCostOfDecorations(bool fancy) {
        if (fancy)
        {
            CostOfDecorations = (NumberOfPeople * 15.00M) + 50M;
        } else {
            CostOfDecorations = (NumberOfPeople * 7.50M) + 30M;
        }
    }

    public decimal CalculateCost(bool healthyOption) {
        decimal totalCost = CostOfDecorations +
            ((CostOfBeveragesPerPerson + CostOfFoodPerPerson)
                * NumberOfPeople);

        if (healthyOption) {
            return totalCost * .95M;
        } else {
            return totalCost;
        }
    }
}
```

Using a constant for `CostOfFoodPerPerson` ensures the value can't be changed. It also makes the code easier to read—it's clear that this value never changes.

When the form first creates the object, it uses the initializer to set `NumberOfPeople`. Then it calls `SetHealthyOption()` and `CalculateCostOfDecorations()` to set the other fields.

We used "if (Fancy)" instead of typing "if (Fancy == true)" because the if statement always checks if the condition is true.

We used parentheses to make sure the math works out properly.

This applies the 5% discount to the overall event cost if the non-alcoholic option was chosen.

We had you use a decimal for the prices because it's designed for monetary values. Just make sure you always put an "M" after every literal—so if you want to store \$35.26, make sure you write 35.26M.

```
public partial class Form1 : Form {
    DinnerParty dinnerParty;
    public Form1() {
        InitializeComponent();
        dinnerParty = new DinnerParty() { NumberOfPeople = 5 };
        dinnerParty.CalculateCostOfDecorations (fancyBox.Checked);
        dinnerParty.SetHealthyOption (healthyBox.Checked);
        DisplayDinnerPartyCost ();
    }

    private void fancyBox_CheckedChanged(object sender, EventArgs e) {
        dinnerParty.CalculateCostOfDecorations (fancyBox.Checked);
        DisplayDinnerPartyCost ();
    }

    private void healthyBox_CheckedChanged(object sender, EventArgs e) {
        dinnerParty.SetHealthyOption (healthyBox.Checked);
        DisplayDinnerPartyCost ();
    }

    private void numericUpDown1_ValueChanged(object sender, EventArgs e) {
        dinnerParty.NumberOfPeople = (int)numericUpDown1.Value;
        DisplayDinnerPartyCost ();
    }

    private void DisplayDinnerPartyCost () {
        decimal Cost = dinnerParty.CalculateCost (healthyBox.Checked);
        costLabel.Text = Cost.ToString ("c");
    }
}
```

We call `DisplayDinnerPartyCost` to initialize the label that shows the cost as soon as the form's loaded.

Changes to the checkboxes on the form set the `healthyOption` and `Fancy` booleans to true or false in the `SetHealthyOption()` and `CalculateCostOfDecorations()` methods.

We named our checkboxes "healthyBox" and "fancyBox" so you could see what's going on in their event handler methods.

The new dinner party cost needs to be recalculated and displayed any time the number changes or the checkboxes are checked.

String formatting

You've already seen how you can convert any variable to a string using its `ToString()` method. If you pass "c" to `ToString()`, it converts it to the local currency. You can also pass it "f3" to format it with as a decimal number with three decimal places, "0" (that's a zero) to convert to a whole number, "0%" for a whole number percentage, and "n" to display it as a number with a comma separator for thousands. Take a minute and see how each of these looks in your program!

Kathleen's Test Drive



This rocks!
Estimating is about to
get a whole lot easier.

Rob's one of Kathleen's
favorite clients. She did his
wedding last year, and now
she's planning an important
dinner party for him.

Rob (on phone): Hi Kathleen. How are the arrangements for my dinner party going?

Kathleen: Just great. We were out looking at decorations this morning and I think you'll love the way the party's going to look.

Rob: That's awesome. Listen, we just got a call from my wife's aunt. She and her husband are going to be visiting for the next couple of weeks. Can you tell me what it does to the estimate to move from 10 to 12 people on the guest list?

Kathleen: Sure! I'll have that for you in just one minute.

Party Planner	
Number of People	12
<input checked="" type="checkbox"/> Fancy decorations	
<input type="checkbox"/> Healthy Option	
Cost	\$665

Changing the Number of
People value from 10 to 12
and hitting enter shows \$665
as the total cost. Hmm, that
seems a little low...

Kathleen: OK. It looks like the total cost for the dinner will go from \$575 to \$665.

Rob: Only \$90 difference? That sounds like a great deal! What if we decide to cut the fancy decorations? What's the cost then?

Turning off the Fancy Decorations checkbox only reduces the amount by \$5. That can't be right!

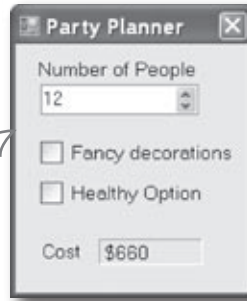

Kathleen: Um, it looks like... um, \$660.

Rob: \$660? I thought the decorations were \$15 per person. Did you change your pricing or something? If it's only \$5 difference, we might as well go with the Fancy Decorations. I've gotta tell you though, this pricing is confusing.

Kathleen: We just had this new program written to do the estimation for us. But it looks like there might be a problem. Just one second while I add the fancy decorations back to the bill.

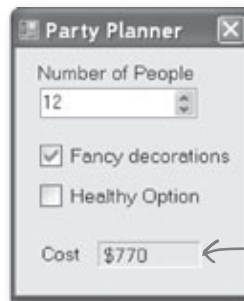

When you turn the Fancy Decorations back on, the number shoots up to \$770. These numbers are just wrong.

Kathleen: Rob, I think there's been a mistake. It looks like the cost with the fancy decorations just shot up to \$770. That does seem to make more sense. But I am beginning not to trust this application. I'm going to send it back for some bug fixes and work up your estimate by hand. Can I get back to you tomorrow?

Rob: I am not paying \$770 just to add two people to the party. The price you quoted me before was a lot more reasonable. I'll pay you the \$665 you quoted me in the first place, but I just can't go higher than that!



Why do you think the numbers are coming out wrong every time Kathleen makes a change?

wasn't expecting that

Each option should be calculated individually

Even though we made sure to calculate all of the amounts according to what Kathleen said, we didn't think about what would happen when people made changes to just one of the options on the form.

When you launch the program, the form sets the number of people to 5 and Fancy Decorations to true. It leaves Healthy Option unchecked and it calculates the cost of the dinner party as \$350. Here's how it comes up with the initial total cost:

5 people.

\$20 per person for drinks → Total cost of drinks = \$100

\$25 per person for food → Total cost of food = \$125

\$15 per person for decorations plus \$50 fee. → Total cost of Decorations = \$125



**Don't worry!
This one
wasn't your
fault.**

We built a nasty little bug into the code we gave you to show you just how easy it is to have problems with how objects use each others' fields... and just how hard those problems are to spot.

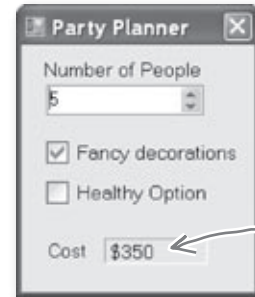

$\$100 + \$125 + 125 = \$350$

When you change the number of guests, the application should recalculate the total estimate the same way. But it doesn't:

10 people.

\$20 per person for drinks → Total cost of drinks = \$200

\$25 per person for food → Total cost of food = \$250

\$15 per person for decorations plus \$50 fee. → Total cost of Decorations = \$200

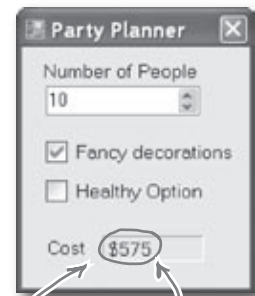

$\$200 + \$250 + 200 = \$650$

This is the total we should get. But we're not...

The program is adding the old cost of decorations up with the new cost of food and drink.

It's doing $\$200 + \$250 + \$125 = \575 .

New food and drink cost.

Old decorations.

The Problem Up Close



Take a look at the method that handles changes to the value in the numericUpDown control. It sets the value from the field to the NumberOfPeople variable and then calls the DisplayDinnerPartyCost () method. Then it counts on that method to handle recalculating all the individual new costs.

```
private void numericUpDown1_ValueChanged(
    object sender, EventArgs e) {
    dinnerParty.NumberOfPeople = (int)numericUpDown1.Value;
    DisplayDinnerPartyCost ();
}
```

This line sets the value of NumberOfPeople in this instance of DinnerParty to the value in the form.

This method calls the CalculateCost () method, but not the CalculateCostOfDecorations () method.

So, when you make a change to the value in the NumberOfPeople field, this method never gets called:

```
public void CalculateCostOfDecorations (bool Fancy) {
    if (Fancy) {
        CostOfDecorations = (NumberOfPeople * 15.00M) + 50M;
    } else {
        CostOfDecorations = (NumberOfPeople * 7.50M) + 30M;
    }
}
```

This variable is set to \$125 from when the form first called it and, since this method doesn't get called again, it doesn't change.

That's why the number corrects itself when you turn fancy decorations back on. Clicking the checkbox makes the program run CalculateCostOfDecorations () again.



Hold on! I assumed Kathleen would always set all three options at once!

People won't always use your programs in exactly the way you expect.

Luckily, C# gives you a powerful tool to make sure your program always works correctly—even when people do things you never thought of. It's called **encapsulation** and it's a really helpful technique for working with objects.

It's easy to accidentally misuse your objects

Kathleen ran into problems because her form ignored the convenient `CalculateCostOfDecorations()` method that you set up and instead went directly to the fields in the `DinnerParty` class. So even though your `DinnerParty` class worked just fine, the form called it in an unexpected way... and that caused problems.

1 How the `DinnerParty` class expected to be called

The `DinnerParty` class gave the form a perfectly good method to calculate the total cost of decorations. All it had to do was set the number of people and then call `CalculateCostOfDecorations()`, and then `CalculateCost()` will return the correct cost.

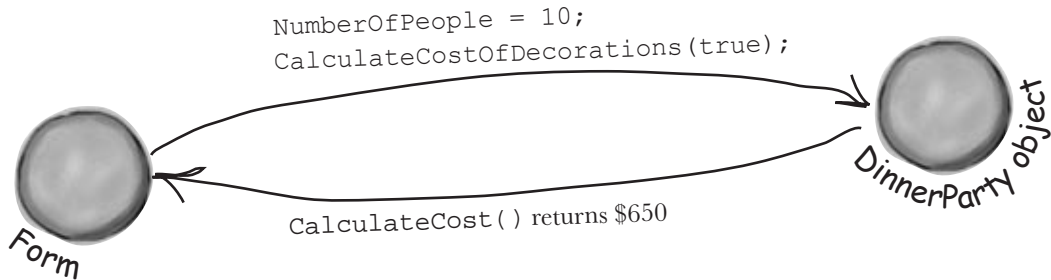

2 How the `DinnerParty` class was actually called

The form set the number of people, but just called the `CalculateCost()` method without first recalculating the cost of the decorations. That threw off the whole calculation, and Kathleen ended up giving Rob the wrong price.

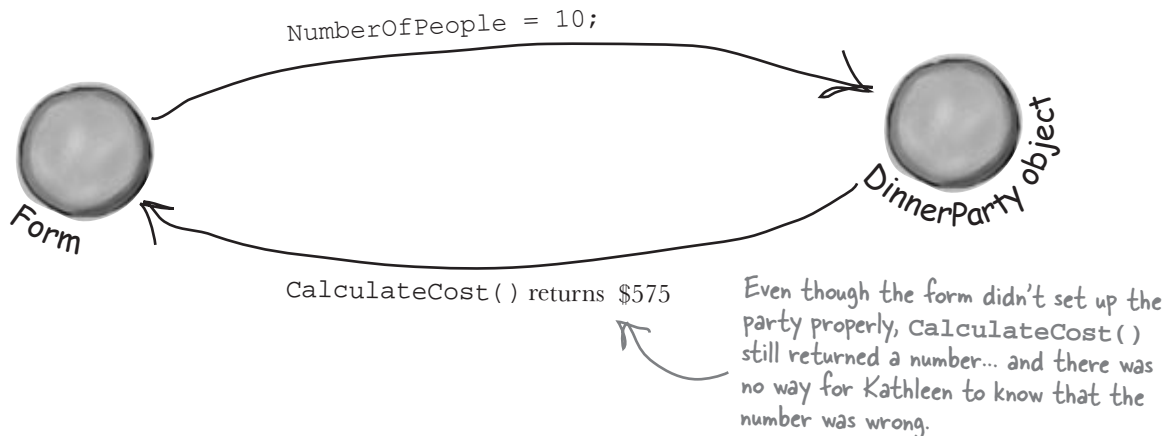

Encapsulation means keeping some of the data in a class private

There's an easy way to avoid this kind of problem: make sure that there's only one way to use your class. Luckily, C# makes it easy to do that by letting you declare some of your fields as **private**. So far, you've only seen public fields. If you've got an object with a public field, any other object can read or change that field. But if you make it a private field, then **that field can only be accessed from inside that object** (or by another object of *the same class*).

Use your laziness to your own benefit—if you leave off the “private” or “public”, then C# will just assume that your field is private.

```
public class DinnerParty {
    private int numberOfPeople;
    ...

```

If you want to make a field private, all you need to do is use the `private` keyword when you declare it. That tells C# that if you've got an instance of `DinnerParty`, its `numberOfPeople` field can only be read and written by that instance. Other objects won't even know it's there.

```
    public void SetPartyOptions(int people, bool fancy) {
        numberOfPeople = people;
        CalculateCostOfDecorations(fancy);
    }

    public int GetNumberOfPeople() {
        return numberOfPeople;
    }

```

Other objects still need a way to set the number of people for the dinner party. One good way to give them access to it is to add methods to set or get the number of people. That way you can make sure that the `CalculateCostOfDecorations()` method gets run every time the number of people is changed. That'll take care of that pesky bug.

By making the field that holds the number of party guests *private*, we only give the form one way to tell the `DinnerParty` class how many people are at the party—and we can make sure the cost of decorations is recalculated properly. When you make some data private and then write code to use that data, it's called *encapsulation*.

en-cap-su-la-ted, adj.
enclosed by a protective coating or membrane. *The divers were fully **encapsulated** by their submersible, and could only enter and exit through the airlock.*

Use encapsulation to control access to your class's methods and fields

When you make all of your fields and methods public, any other class can access them. Everything your class does and knows about becomes an open book for every other class in your program... and you just saw how that can cause your program to behave in ways you never expected. Encapsulation lets you control what you share and what you keep private inside your class. Let's see how this works:

- 1 Super-spy Herb Jones is defending life, liberty, and the pursuit of happiness as an undercover agent in the USSR. His `ciaAgent` object is an instance of the `SecretAgent` class.



RealName: "Herb Jones"
 Alias: "Dash Martin"
 Password: "the crow flies at midnight"

SecretAgent
Alias RealName Password
AgentGreeting()

- 2 Agent Jones has a plan to help him evade the enemy KGB agents. He added an `AgentGreeting()` method that takes a password as its parameter. If he doesn't get the right password, he'll only reveal his alias, Dash Martin.

EnemyAgent
Borscht Vodka
ContactComarades() OverthrowCapitalists()

- 3 Seems like a foolproof way to protect the agent's identity, right? As long as the agent object that calls it doesn't have the right password, the agent's name is safe.

The `ciaAgent` object is an instance of the `SecretAgent` class, while `kgbAgent` is an instance of `EnemyAgent`.



`AgentGreeting("the jeep is parked outside")`

The KGB agent uses the wrong password in his greeting.

"Dash Martin"

The KGB only gets the alias of the CIA agent. Perfect. Right?



But is the `realName` field REALLY protected?

So as long as the KGB doesn't know any CIA agent passwords, the CIA's real names are safe. Right? But what about the field declaration for the `realName` field:

Setting your variables public means they can be accessed, and even changed, from outside the class.

```
public string RealName;
```

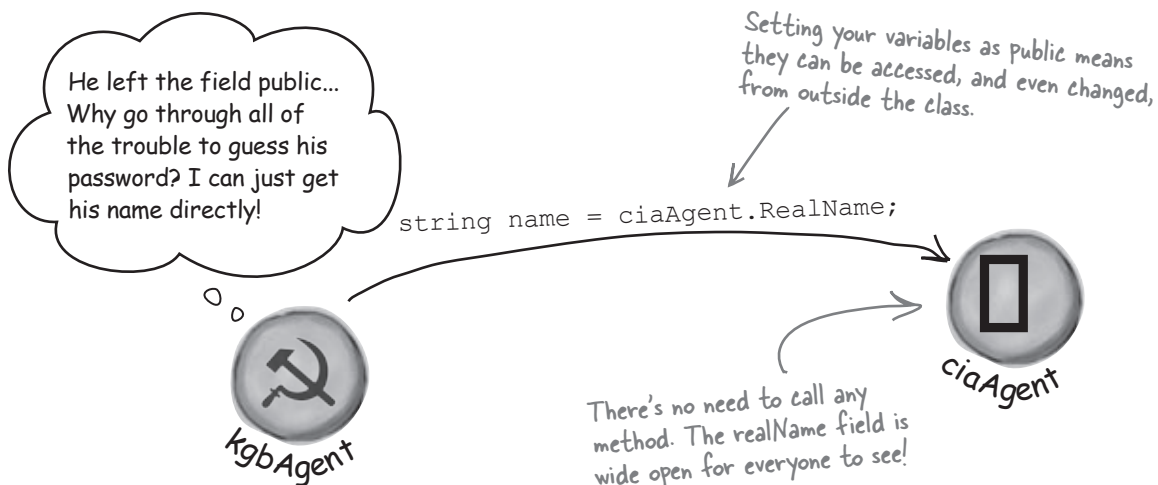

Agent Jones can use **private** fields to keep his identity secret from enemy spy objects. Once he declares the `realName` field as private, the only way to get to it is **by calling methods that have access to the private parts of the class**. So the KGB agent is foiled!

The `kgbAgent` object can't access the `ciaAgent`'s private fields because they're instances of different classes.

Just replace public with private, and boom, your fields are now hidden from the world.

```
private string realName;
```

You'd also want to make sure that the field that stores the password is private, otherwise the enemy agent can get to it.

Keeping your fields and methods private makes sure no outside code is going to make changes to the values you're using when you don't expect it.

Private fields and methods can only be accessed from inside the class

There's only one way that an object can get at the data stored inside another object's private fields: by using the public fields and methods that return the data. But while KGB and MI5 agents need to use the `AgentGreeting()` method, friendly spies can see everything—any class can **see private fields in other instances of the same class**.

mi5gent is an instance of the `BritishAgent` class, so it doesn't have access to `ciaAgent`'s private fields either.

Only another `ciaAgent` object can see them.



`AgentGreeting("the crow flies at midnight")`

Now that the fields are private, this is pretty much the only way the `mi5Agent` can get the `ciaAgent`'s real name.



"Herb Jones"

there are no Dumb Questions

Q: Okay, so I need to access private data through public methods. But what happens if the class with the private field doesn't give me a way to get at that data, but my object needs to use it?

A: Then you can't access the data from outside the object. When you're writing a class, you should always make sure that you give other objects some way to get at the data they need. Private fields are a very important part of encapsulation, but they're only part of the story. Writing a class with good encapsulation means giving a sensible, easy-to-use way for other objects to get the data they need, without giving them access to hijack data your class needs.

Q: Why would I ever want to keep a field with no way for another class to access?

A: Sometimes a class needs to keep track of information that is necessary for it to operate, but which no other object really needs to see. Here's an example. When computers generate random numbers, they use special values called *seeds*. You don't need to know how they work, but every instance of

`Random` actually contains an array of several dozen numbers that it uses to make sure that `Next()` always gives you a random number. If you create an instance of `Random`, you won't be able to see that array. That's because you don't need it—but if you had access to it, you might be able to put values in it that would cause it to give non-random values. So the seeds have been completely encapsulated from you.

Q: Hey, I just noticed that all of the event handlers I've been using have the `private` keyword. Why are they private?

A: Because C# forms are set up so that only the controls on the forms can trigger event handlers. When you put the `private` keyword in front of any method, then that method can only be used from inside your class. When the IDE adds an event handler method to your program, it declares it as `private` so other forms or objects can't get to it. But there's no rule that says that an event handler must be `private`. In fact, you can check this out for yourself—double-click on a button, then change its event handler declaration to `public`. The code will still compile and run.

The only way that one object can get to data stored in a private field inside another object is by using public methods that return the data.



Here's a class with some private fields. Circle the statements below that **won't compile** if they're run from outside the class using **an instance of the object called mySuperChef**.

```
public class SuperChef
{
    public string cookieRecipe;
    private string secretIngredient;
    private const int loyalCustomerOrderAmount = 60;
    public int Temperature;
    private string ingredientSupplier;

    public string GetRecipe (int orderAmount)
    {
        if (orderAmount >= loyalCustomerOrderAmount)
        {
            return cookieRecipe + " " + secretIngredient;
        }
        else
        {
            return cookieRecipe;
        }
    }
}
```

1. string ovenTemp = mySuperChef.Temperature;
2. string supplier = mySuperChef.ingredientSupplier;
3. int loyalCustomerOrderAmount = 94;
4. mySuperChef.secretIngredient = "cardamom";
5. mySuperChef.cookieRecipe = "get 3 eggs, 2 1/2 cup flour, 1 tsp salt, 1 tsp vanilla and 1.5 cups sugar and mix them together. Bake for 10 minutes at 375. Yum!";
6. string recipe = mySuperChef.GetRecipe(56);
7. After running all of the lines that will compile above, what's the value of recipe?

.....

Sharpen your pencil Solution

Here's a class with some private fields. Circle the statements below that **won't compile** if they're run from outside the class using **an instance of the object called mySuperChef**.

```
public class SuperChef
{
    public string cookieRecipe;
    private string secretIngredient;
    private const int loyalCustomerOrderAmount = 60;
    public int Temperature;
    private string ingredientSupplier;

    public string GetRecipe (int orderAmount)
    {
        if (orderAmount >= loyalCustomerOrderAmount)
        {
            return cookieRecipe + " and the secret ingredient is "
                + secretIngredient;
        }
        else
        {
            return cookieRecipe;
        }
    }
}
```

The only way to get the secret ingredient is to order a whole lot of cookies. Outside code can't access this field directly.

1. string ovenTemp = mySuperChef.Temperature;

#1 doesn't compile because you can't just assign an int to a string.

2. string supplier = mySuperChef.ingredientSupplier;

3. int loyalCustomerOrderAmount = 54;

#2 and #4 don't compile because ingredientSupplier and secretIngredient are private.

4. mySuperChef.secretIngredient = "cardamom";

5. mySuperChef.cookieRecipe = "Get 3 eggs, 2 1/2 cup flour, 1 tsp salt, 1 tsp vanilla and 1.5 cups sugar and mix them together. Bake for 10 minutes at 375. Yum!";

Even though you created a local variable called loyalCustomerAmount and set it to 54, that didn't change the object's loyalCustomerAmount value, which is still 60—so it won't print the secret ingredient.

6. string recipe = mySuperChef.GetRecipe(56);

7. After running all of the lines that will compile above, what's the value of recipe?

.....
"Get 3 eggs, 2 1/2 cup flour, 1 tsp salt, 1 tsp vanilla and 1.5 cups sugar and mix them together."
.....

.....
"Bake for 10 minutes at 375. Yum!"
.....

A few ideas for encapsulating classes

★ Think about ways the fields can be misused.

What can go wrong if they're not set properly?

★ Is everything in your class public?

If your class has nothing but public fields and methods, you probably need to spend a little more time thinking about encapsulation.

★ What fields require some processing or calculation to happen when they're set?

Those are prime candidates for encapsulation. If someone writes a method later that changes the value in any one of them, it could cause problems for the work your program is trying to do.



★ Only make fields and methods public if you need to.

If you don't have a reason to declare something public, don't. You could make things really messy for yourself by making all of the fields in your program public—but don't just go making everything private, either. Spending a little time up front thinking about which fields really need to be public and which don't can save you a lot of time later.

Encapsulation keeps your data pristine

Sometimes the value in a field changes as your program does what it's supposed to do. If you don't explicitly tell your program to reset the value, you can do your calculations using the old one. When this is the case, you want to have your program execute some statements any time a field is changed—like having Kathleen's program recalculate the cost every time you change the number of people. We can avoid the problem by encapsulating the data using private fields. We'll provide a method to get the value of the field, and another method to set the field and do all the necessary calculations.

A quick example of encapsulation

A Farmer class uses a field to store the number of cows, and multiplies it by a number to figure out how many bags of cattle feed are needed to feed the cows:

```
class Farmer
{
    private int numberOfCows;
}
```

We'd better make this field private so nobody can change it without also changing `bagsOfFeed`—if they get out of sync, that'll create bugs!

When you create a form to let a user enter the number of cows into a numeric field, you need to be able to change the value in the `numberOfCows` field. To do that, you can create a method that returns the value of the field to the form object.

```
public const int FeedMultiplier = 30;
public int GetNumberOfCows()
{
    return numberOfCows;
}

public void SetNumberOfCows(int newNumberOfCows)
{
    numberOfCows = newNumberOfCows;
    BagsOfFeed = numberOfCows * FeedMultiplier;
}
```

The farmer needs 30 bags of feed for each cow.

We'll add a method to give other classes a way to get the number of cows.

These accomplish the same thing!

We used camelCase for the private fields and PascalCase for the public ones. PascalCase means capitalizing the first letter in every word in the variable name. camelCase is similar to PascalCase, except that the first letter is lowercase. That makes the uppercase letters look like "humps" of a camel.

And here's a method to set the number of cows that makes sure the `BagsOfFeed` field is changed too. Now there's no way for the two to get out of sync.

Properties make encapsulation easier

C# has special kinds of methods that make it easy to encapsulate your data. You can use **properties**, methods that are executed every time a property is used to set or return the value of the field, which is called a **backing field**.

```
private int numberOfCows;
public int NumberOfCows
{
    get
    {
        return numberOfCows;
    }
    set
    {
        numberOfCows = value;
        BagsOfFeed = numberOfCows * FeedMultiplier;
    }
}
```

We'll rename the private field to `numberOfCows` (notice the lowercase "n"). This will become the **backing field** for the `NumberOfCows` property.

You'll often use properties by combining them with a normal field declaration. Here's the declaration for `NumberOfCows`.

This is a **get accessor**. It's a method that's run any time the `NumberOfCows` property is **read**. It has a return value that matches the type of the variable—in this case it returns the value of the private `numberOfCows` property.

This is a **set accessor** that's called every time the `NumberOfCows` property is **set**. Even though the method doesn't look like it has any parameters, it actually has one called **value** that contains whatever value the field was set to.

You **use** get and set accessors exactly like fields. Here's code for a button that sets the numbers of cows and then gets the bags of feed:

```
private void button1_Click(object sender, EventArgs e) {
    Farmer myFarmer = new Farmer();
    myFarmer.NumberOfCows = 10;

    int howManyBags = myFarmer.BagsOfFeed;

    myFarmer.NumberOfCows = 20;
    howManyBags = myFarmer.BagsOfFeed;
}
```

When this line sets `NumberOfCows` to 10, the **set accessor** sets the private `numberOfCows` field and then updates the public `BagsOfFeed` field.

Since the `NumberOfCows` set accessor updated `BagsOfFeed`, now you can get its value.

Even though the code treats `NumberOfCows` like a field, it runs the **set accessor**, passing it 20. And when it queries the `BagsOfFeed` field it runs the **get accessor**, which returns 300.

Build an application to test the Farmer class

Create a new Windows Forms application that we can use to test the Farmer class and see properties in action. We'll use the `Console.WriteLine()` method to write the results to the output window in the IDE.



- 1 Add the Farmer class to your project:

```
public class Farmer {
    public int BagsOfFeed;
    public const int FeedMultiplier = 30;

    private int numberOfCows;
    public int NumberOfCows {
        (add the get and set accessors from the previous page)
    }
}
```

- 2 Build this form:

Name this button "calculate"—it uses the public Farmer data to write a line to the output.

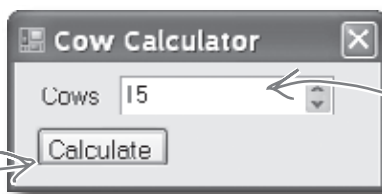

Set the NumericUpDown control's Value to 15, its Minimum to 5, and its Maximum to 300.

- 3 Here's the form for the code. It uses `Console.WriteLine()` to send its output to the Output window (which you can bring up by selecting "Output" from the View menu). You can pass several parameters to `WriteLine()`—the first one is the string to write. If you include "{0}" inside the string, then `WriteLine()` replaces it with the first parameter. It replaces "{1}" with the second parameter, "{2}" with the third, etc.

```
public partial class Form1 : Form {
    Farmer farmer;
    public Form1() {
        InitializeComponent();
        farmer = new Farmer() { NumberOfCows = 15 };
    }
    private void numericUpDown1_ValueChanged(object sender, EventArgs e) {
        farmer.NumberOfCows = (int)numericUpDown1.Value;
    }
    private void calculate_Click(object sender, EventArgs e) {
        Console.WriteLine("I need {0} bags of feed for {1} cows",
            farmer.BagsOfFeed, farmer.NumberOfCows);
    }
}
```

Use the `Console.WriteLine()` method to send a line of text to the IDE's Output window.

`WriteLine()` replaces "{0}" with value in the first parameter, and "{1}" with the second parameter.

Use automatic properties to finish the class

It looks like the Cow Calculator works really well. Give it a shot—run it and click the button. Then change the number of cows to 30 and click it again. Do the same for 5 cows and then 20 cows. Here's what your Output window should look like:

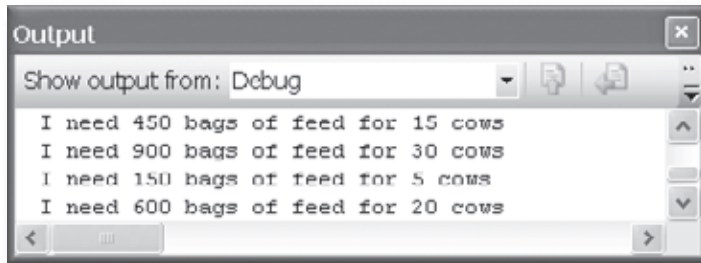

But there's a problem with the class. Add a button to the form that executes this statement:

```
farmer.BagsOfFeed = 5;
```

Now run your program again. It works fine until you press the new button. But press that button and then press the Calculate button again. Now your output tells you that you need 5 bags of feed—no matter how many cows you have!

Fully encapsulate the Farmer class

The problem is that your class **isn't fully encapsulated**. You used properties to encapsulate `NumberOfCows`, but `BagsOfFeed` is still public. This is a common problem. In fact, it's so common that C# has a way of automatically fixing it. Just change the public `BagsOfFeed` field to an **automatic property**. And the IDE makes it really easy for you to add automatic properties. Here's how:

- 1 Remove the `BagsOfFeed` field from the `Farmer` class. Put your cursor where the field used to be, and then type **prop** and press the tab key twice. The IDE will add this line to your code:

```
public int MyProperty { get; set; }
```

- 2 Press the tab key—the cursor jumps to `MyProperty`. Change its name to `BagsOfFeed`:

```
public int BagsOfFeed { get; set; }
```

Now you've got a property instead of a field. When C# sees this, it works exactly the same as if you used a backing field (like the private `numberOfCows` behind the public `NumberOfCows` property).

- 3 That hasn't fixed our problem yet. But there's an easy fix—just make it a **read-only property**:

```
public int BagsOfFeed { get; private set; }
```

Try to rebuild your code—you'll get an error on the line in the button that sets `BagsOfFeed` telling you that the **set accessor is private**. You can't modify `BagsOfFeed` from outside the `Farmer` class—you'll need to remove that line in order to get your code to compile, so remove the button from the form. Now your `Farmer` class is better encapsulated!



Watch it!

Automatic properties are a C# 3.0 feature.

If you're still using Visual Studio 2005 and C# 2.0, this code won't work. We highly recommend that you use Visual Studio 2008 Express. You can download it for free!

The prop-tab-tab code snippet adds an automatic property to your code.

What if we want to change the feed multiplier?

We built the Cow Calculator to use a `const` for the feed multiplier. But what if we want to use the same `Farmer` class in different programs that need different feed multipliers? You've seen how poor encapsulation can cause problems when you make fields in one class too accessible to other classes. That's why you should **only make fields and methods public if you need to**. Since the Cow Calculator never updates `FeedMultiplier`, there's no need to allow any other class to set it. So let's change it to a read-only property that uses a backing field.



- 1 Remove this line from your program:

```
public const int FeedMultiplier = 30;
```

Use prop-tab-tab to add a read-only property. But instead of adding an automatic property, use a backing field:

```
private int feedMultiplier;
public int FeedMultiplier { get { return feedMultiplier; } }
```

This property acts just like an int field, except instead of storing a value it just returns the backing field, `feedMultiplier`. And since there's no set accessor, it's read-only. It has a public get, which means any other class can read the value of `FeedMultiplier`. But since its set is private, that makes it read-only—it can only be set by an instance of `Farmer`.

Since we changed `FeedMultiplier` from a public const to a private int field, we changed its name, so it starts with a lowercase "f". That's a pretty standard naming convention you'll see throughout the book.

- 2 Go ahead and make that change to your code. Then run it. Uh-oh—something's wrong! `BagsOfFeed` **always returns 0 bags!**

Wait, that makes sense. `FeedMultiplier` never got initialized. It starts out with the default value of zero and never changes. When it's multiplied by the number of cows, it still gives you zero. So add an object initializer:

```
public Form1() {
    InitializeComponent();
    farmer = new Farmer() { NumberOfCows = 15, feedMultiplier = 30 };
}
```

Uh-oh—the program won't compile! You should get this error:

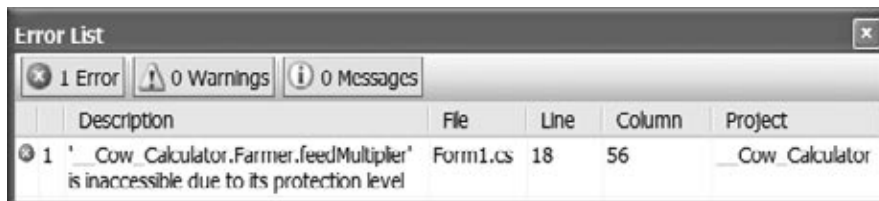

You can only initialize public fields and properties inside an object initializer. So how can you make sure your object gets initialized properly if some of the fields that need to be initialized are private?

Use a constructor to initialize private fields

If you need to initialize your object, but some of the fields that need to be initialized are private, then an object initializer just won't do. Luckily, there's a special method that you can add to any class called a **constructor**. If a class has a constructor, then that constructor is the **very first thing that gets executed** when the class is created with the new statement. You can pass parameters to the constructor to give it values that need to be initialized. But the constructor **does not have a return value**, because you don't actually call it directly. You pass its parameters to the new statement. And you already know that new returns the object—so there's no way for a constructor to return anything.

All you have to do to add a constructor to a class is add a method that has the same name as the class and no return value.

1 Add a constructor to your Farmer class

This constructor only has two lines, but there's a lot going on here. So let's take it step by step. We already know that we need the number of cows and a feed multiplier for the class, so we'll add them as parameters to the constructor. Since we changed `feedMultiplier` from a `const` to an `int`, now we need an initial value for it. So let's make sure it gets passed into the constructor. We'll need a value for it, so let's make sure it gets passed into the constructor. We'll use the constructor to set the number of cows, too.

Notice how there's no "void" or "int" or another type after "public". That's because constructors don't have a return value.

```
public Farmer(int numberOfCows, int feedMultiplier) {
    this.feedMultiplier = feedMultiplier;
    NumberOfCows = numberOfCows;
}
```

If we just set the private `numberOfCows` field, the `NumberOfCows` set accessor would never be called. Setting `NumberOfCows` makes sure it's called.

The 'this' keyword in `this.feedMultiplier` tells C# that you're talking about the field, not the parameter with the same name.

The first thing we'll do is set the feed multiplier, because it needs to be set before we can call the `NumberOfCows` set accessor.

This is the error you'll get if your constructor takes parameters but your new doesn't have any.

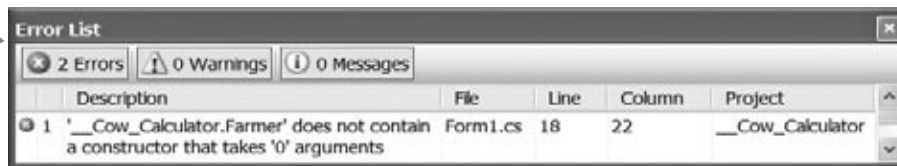

2 Now change the form so that it uses the constructor

The only thing you need to do now is change the form so that the new statement that creates the `Farmer` object uses the constructor instead of an object initializer. Once you replace the new statement, both errors will go away, and your code will work!

```
public Form1() {
    InitializeComponent();
    farmer = new Farmer(15, 30);
}
```

Here's where the new statement calls the constructor. It looks just like any other new statement, except that it has parameters that it passes into the constructor method. When you type it in, watch for the IntelliSense pop-up—it looks just like any other method.

You already know that the form is an object. Well, it's got a constructor too! That's what this method is—notice how it's named `Form1` (like the class) and it doesn't have a return value.



Constructors Way Up Close

Constructors don't return anything, so there's no return type.

Let's take a closer look at the Farmer constructor so we can get a good sense of what's really going on.

This constructor has two parameters, which work just like ordinary parameters. The first one gives the number of cows, and the second one is the feed multiplier.

```
public Farmer(int numberOfCows, int feedMultiplier) {
```

```
    this.feedMultiplier = feedMultiplier;
    NumberOfCows = numberOfCows;
}
```

We need to set the feed multiplier first, because the second statement calls the NumberOfCows set accessor, which needs feedMultiplier to have a value in order to set BagsOfFeed.

We need a way to differentiate the field called feedMultiplier from the parameter with the same name. That's where the "this." keyword comes in really handy.

Since "this" is always a reference to the current object, this.feedMultiplier refers to the field. If you leave "this" off, then feedMultiplier refers to the parameter. So the first line in the constructor sets the private feedMultiplier field equal to the second parameter of the constructor.

there are no Dumb Questions

Q: Is it possible to have a constructor without any parameters?

A: Yes. It's actually very common for a class to have a constructor without a parameter. In fact, you've already seen an example of it—**your form's constructor**. Look inside a newly added Windows form and find its constructor's declaration:

```
public Form1() {
    InitializeComponent();
}
```

That's the constructor for your form object. It doesn't take any parameters, but it does have to do a lot. Take a minute and open up `Form1.Designer.cs`. Find the `InitializeComponent()` method by clicking on the plus symbol next to "Windows Form Designer generated code".

That method initializes all of the controls on the form and sets all of their properties. If you drag a new control onto your form in the IDE's form designer and set some of its properties in the Properties window, you'll see those changes reflected inside the `InitializeComponent()` method.

The `InitializeComponent()` method is called inside the form's constructor so that the controls all get initialized as soon as the form object is created. (Remember, every form that gets displayed is just another object that happens to use methods that the .NET Framework provides in the `System.Windows.Forms` namespace to display windows, buttons and other controls.)



Watch it!

When a method's parameter has the same name as a field, then it masks the field.

Did you notice how the constructor's `feedMultiplier` parameter looks just like the backing field behind the `FeedMultiplier` property? If you wanted to use the backing field in of the constructor, you'd use "this.": `feedMultiplier` refers to the parameter, and `this.feedMultiplier` is how you'd access the private field.

there are no Dumb Questions

Q: Why would I need complicated logic in a get or set accessor? Isn't it just a way of creating a field?

A: Because sometimes you know that every time you set a field, you'll have to do some calculation or perform some action. Think about Kathleen's problem—she ran into trouble because the form didn't run the method to recalculate the cost of the decorations after setting the number of people in the `DinnerParty` class. If we replaced the field with a set accessor, then we could make sure that the set accessor recalculates the cost of the decorations. (In fact, you're about to do exactly that in just a couple of pages!)

Q: Wait a minute—so what's the difference between a method and a get or set accessor?

A: There is none! Get and set accessors are a special kind of method—one that looks just like a field to other objects, and called whenever that field is set. Get accessors always return a value that's the same type as the field, and set accessors always take exactly one parameter called `value` whose type is the same as the field. Oh, and by the way, you can just say "property" instead of "get and set accessor".

Q: So you can have ANY kind of statement in a property?

A: Absolutely. Anything you can do in a method, you can do in a property. They can call other methods, access other fields, even create objects and instances. But they only get called when a property gets accessed, so it doesn't make sense to have any statements in them that don't have to do with getting or setting the property.

Q: If a set accessor always takes a parameter called `value`, why doesn't its declaration have parentheses with "int `value`" in them, like you'd have with any other method that takes a parameter called `value`?

A: Because C# was built to keep you from having to type in extra information that the compiler doesn't need. The parameter gets declared without you having to explicitly type it in, which doesn't sound like much when you're only typing one or two—but when you have to type a few hundred, it can be a real time saver (not to mention a bug preventer).

Every set accessor *always* has exactly one parameter called `value`, and the type of that parameter *always* matches the type of the property. C# has all the information it needs about the type and parameter as soon as you type `set {`. So there's no need for you to type any more, and the C# compiler isn't going to make you type more than you have to.

Q: Wait, a sec—is that why I don't add a return value to my constructor?

A: Exactly! Your constructor doesn't have a return value because *every* constructor is always `void`. It would be redundant to make you type "void" at the beginning of each constructor, so you don't have to.

Q: Can I have a get without a set or a set without a get?

A: Yes! When you have a get accessor but no set, you create a read-only property. For example, the `SecretAgent` class might have a `ReadOnly` field for the name:

```
string name = "Dash Martin";
public string Name {
    get { return name; }
}
```

And if you create a property with a set accessor but no get, then your backing field can only be written, but not read. The `SecretAgent` class could use that for a `Password` property that other spies could write to but not see:

```
public string Password {
    set {
        if (value == secretCode) {
            name = "Herb Jones";
        }
    }
}
```

Both of those techniques can come in really handy when you're doing encapsulation.

Properties (get and set accessors) are a special kind of method that's only run when another class reads or writes a property.



Take a look at the get and set accessors here. The Form that is using this class has a new instance of CableBill called thisMonth and calls the GetThisMonthsBill () method with a button click. Write down the value of the amountOwed variable after the code below executed.

```
public class CableBill {
    private int rentalFee;
    public CableBill(int rentalFee) {
        this.rentalFee = rentalFee;
        discount = false;
    }

    private int payPerViewDiscount;
    private bool discount;
    public bool Discount {
        set {
            discount = value;
            if (discount)
                payPerViewDiscount = 2;
            else
                payPerViewDiscount = 0;
        }
    }

    public int CalculateAmount(int payPerViewMoviesOrdered) {
        return (rentalFee - payPerViewDiscount) * payPerViewMoviesOrdered;
    }
}
```

1. CableBill january = new CableBill(4);
 MessageBox.Show(january.CalculateAmount(7).ToString());

What's the value of amountOwed?

2. CableBill february = new CableBill(7);
 february.payPerViewDiscount = 1;
 MessageBox.Show(february.CalculateAmount(3).ToString());

What's the value of amountOwed?

3. CableBill march = new CableBill(9);
 march.Discount = true;
 MessageBox.Show(march.CalculateAmount(6).ToString());

What's the value of amountOwed?

there are no Dumb Questions

Q: I noticed that you used uppercase names for some fields but lowercase ones for others. Does that matter?

A: Yes—it matters to you. But it doesn't matter to the compiler. C# doesn't care what you name your variables, but if you choose weird names then it makes your code hard to read. Sometimes it can get confusing when you have variables that are named the same, except one starts with an uppercase letter and the other starts with a lowercase one.

Case matters in C#. You can have two different variables called `Party` and `party` in the same method. It'll be confusing to read, but your code will compile just fine. Here are a few tips about variable names to help you keep it straight. They're not hard-and-fast rules—the compiler doesn't care whether a variable is uppercase or lowercase—but they're good suggestions to help make your code easier to read.

1. When you declare a private field, it should be in camelCase and start with a lowercase letter. (It's called camelCase because it starts with a lowercase letter and additional words are uppercase, so they resemble humps on a camel.)

2. Public properties and methods are in PascalCase (they start with an uppercase letter).

3. Parameters to methods should be in camelCase.

4. Some methods, especially constructors, will have parameters with the same names as fields. When this happens, the parameter **masks** the field, which means statements in the method that use the name end up referring to the parameter, not the field. Use the `this` keyword to fix the problem—add it to the variable to tell the compiler you're talking about the field, not the parameter.



This code has problems. Write down what you think is wrong with the code, and what you'd change.

```

class GumballMachine {
    private int gumballs;
    .....
    .....private int price;
    .....public int Price
    .....{
    .....    get
    .....    {
    .....        return price;
    .....    }
    .....}
    .....public GumballMachine(int gumballs, int price)
    .....{
    .....    gumballs = this.gumballs;
    .....    price = Price;
    .....}
    .....public string DispenseOneGumball(int price, int coinsInserted)
    .....{
    .....    if (this.coinsInserted >= price) { // check the field
    .....        gumballs -= 1;
    .....        return "Here's your gumball";
    .....    } else {
    .....        return "Please insert more coins";
    .....    }
    .....}
}
    
```

Sharpen your pencil Solution

Write down the value of the amountOwed variable after the code below executed.

1. `CableBill january = new CableBill(4);`
`MessageBox.Show(january.CalculateAmount(7).ToString());`

What's the value of amountOwed?

28

2. `CableBill february = new CableBill(7);`
`february.payPerViewDiscount = 1;`
`MessageBox.Show(february.CalculateAmount(3).ToString());`

What's the value of amountOwed?

won't compile

3. `CableBill march = new CableBill(9);`
`march.Discount = true;`
`MessageBox.Show(march.CalculateAmount(6).ToString());`

What's the value of amountOwed?

42

Sharpen your pencil Solution

This code has problems. Write down what you think is wrong with the code, and what you'd change.

Lowercase `price` refers to the parameter to the constructor, not the field. This line sets the `PARAMETER` to the value returned by the `Price` get accessor, but `Price` hasn't even been set yet! So it doesn't do anything useful. If you change the constructor's parameter to uppercase `Price`, this line will work properly.

```
public GumballMachine(int gumballs, int price)
{
    gumballs = this.gumballs;
    price = Price;
}
```

The "this" keyword is on the wrong "gumballs". `this.gumballs` refers to the property, while `gumballs` refers to the parameter.

This parameter masks the private field called `Price`, and the comment says the method is supposed to be checking the value of the price backing field.

```
public string DispenseOneGumball(int price, int coinsInserted)
```

The "this" keyword is on a parameter, where it doesn't belong. It should be on `price`, because that field is masked by a parameter.

```
if (this.coinsInserted >= price) { // check the field
    gumballs -= 1;
    return "Here's your gumball";
} else {
    return "Please insert more coins";
}
```



Exercise

Use what you've learned about properties and constructors to fix Kathleen's Party Planner program.

1 How to fix the Dinner Party calculator

If we want to fix the DinnerParty class, we'll need a way to make sure that the CalculateCostOfDecorations() method gets called every time that NumberOfPeople changes.

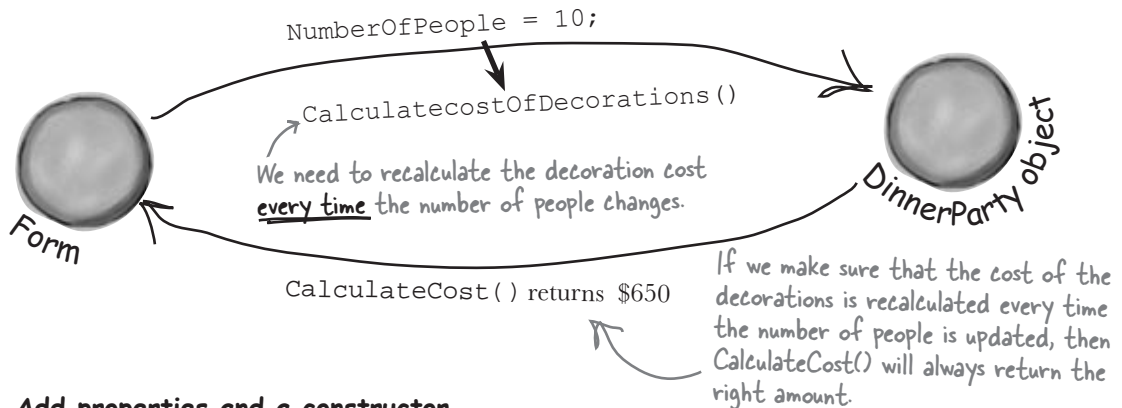

2 Add properties and a constructor

All you need to do to fix Kathleen's problem is make sure the DinnerParty class is well-encapsulated. You'll start by **changing NumberOfPeople to a property** that always calls CalculateCostOfDecorations() any time it's called. Then you'll **add a constructor** that makes sure the instance is initialized properly. Finally, you'll **change the form** so it uses the new constructor. If you do this right, that's the only change you'll need to make to the form.

- ★ You'll need to create a new property for NumberOfPeople that has a set accessor which calls CalculateCostOfDecorations(). It'll need a backing field called numberOfPeople.
- ★ The NumberOfPeople set accessor needs to have a value to pass as the parameter to the CalculateCostOfDecorations() method. So add a private bool field called fancyDecorations that you set every time CalculateCostOfDecorations() is called.
- ★ Add a constructor that sets up the class. It needs to take three parameters for the Number of People, Healthy Option, and Fancy Decorations. The form currently calls two methods when it initializes the DinnerParty object—move them into the constructor.

```
dinnerParty.CalculateCostOfDecorations(fancyBox.Checked);
dinnerParty.SetHealthyOption(healthyBox.Checked);
```

- ★ Here's the constructor for the form—everything else in the form stays the same:

```
public Form1() {
    InitializeComponent();
    dinnerParty = new DinnerParty((int)numericUpDown1.Value,
                                  healthyBox.Checked, fancyBox.Checked);
    DisplayDinnerPartyCost();
}
```



Exercise Solution

Use what you've learned about properties and constructors to fix Kathleen's Party Planner program.

```

public class DinnerParty {
    const int CostOfFoodPerPerson = 25;

    private int numberOfPeople;
    public int NumberOfPeople {
        get { return numberOfPeople; }
        set {
            numberOfPeople = value;
            CalculateCostOfDecorations (fancyDecorations);
        }
    }
    private bool fancyDecorations;

    public decimal CostOfBeveragesPerPerson;
    public decimal CostOfDecorations = 0;

    public DinnerParty(int numberOfPeople, bool healthyOption, bool fancyDecorations) {
        NumberOfPeople = numberOfPeople;
        this.fancyDecorations = fancyDecorations;
        SetHealthyOption(healthyOption);
        CalculateCostOfDecorations (fancyDecorations);
    }

    public void SetHealthyOption(bool healthyOption) {
        if (healthyOption) {
            CostOfBeveragesPerPerson = 5.00M;
        } else {
            CostOfBeveragesPerPerson = 20.00M;
        }
    }

    public void CalculateCostOfDecorations(bool fancy) {
        fancyDecorations = fancy;
        if (fancy) {
            CostOfDecorations = (NumberOfPeople * 15.00M) + 50M;
        } else {
            CostOfDecorations = (NumberOfPeople * 7.50M) + 30M;
        }
    }

    public decimal CalculateCost(bool healthyOption) {
        decimal totalCost = CostOfDecorations
            + ((CostOfBeveragesPerPerson + CostOfFoodPerPerson) * NumberOfPeople);

        if (healthyOption) {
            return totalCost * .95M;
        } else {
            return totalCost;
        }
    }
}
    
```

Now that `numberOfPeople` is private, there's no way for the form to change it without also recalculating the cost of the decorations. That'll fix the bug that almost cost Kathleen one of her best clients!

By using a property, you can make sure that the cost of decorations is recalculated every time the number of people changes.

Be careful how you use "this.". You'll need it to tell the difference between the parameter and private field named `numberOfPeople`.

Make sure you store the fancy decorations in a field so the `NumberOfPeople` set accessor can use it.

So you'll need to put "this." in front of "fancyDecorations" because the fancyDecorations parameter masks the private field with the same name.

6 inheritance

Your object's family tree

So there I was riding my bicycle object down dead man's curve when I realized it inherited from TwoWheeler and I forgot to add a Brakes() method...long story short, twenty-six stitches and Mom said I'm grounded for a month.



Sometimes you **DO** want to be just like your parents.

Ever run across an object that **almost** does exactly what you want **your** object to do? Found yourself wishing that if you could just **change a few things**, that object would be perfect? Well that's just one reason that **inheritance** is one of the most powerful concepts and techniques in the C# language. Before you're through this chapter, you'll learn how to **subclass** an object to get its behavior, but keep the **flexibility** to make changes to that behavior. You'll **avoid duplicate code**, **model the real world** more closely, and end up with code that's **easier to maintain**.

Kathleen does birthday parties, too

Now that you got your program working, Kathleen is using it all the time. But she doesn't just handle dinner parties—she does birthdays too, and they're priced a little differently. She'll need you to add birthdays to her program.



I just got a call for a birthday party for 10 people. Can your program handle that?

These are both the same as the dinner party.

Cost Estimate for a Birthday Party

- \$25 per person.
- There are two options for the cost of decorations. If a client goes with the normal decorations, it's \$7.50 per person with a \$30 decorating fee. A client can also upgrade the party decorations to the "Fancy Option"—that costs \$15 per person with a \$50 one-time decorating fee.
- When the party has four people or less, use an 8-inch cake (\$40). Otherwise, she uses a 16-inch cake (\$75).
- Writing on the cake costs \$.25 for each letter. The 8-inch cake can have up to 16 letters of writing, and the 16-inch one can have up to 40 letters of writing.

Most of the changes have to do with cakes and writing.

The application should handle both types of parties. Use a tab control, one tab for each kind of party.

We need a BirthdayParty class

Modifying your program to calculate the cost of Kathleen's birthday parties means adding a new class and changing the form to let you handle both kinds of parties.

You'll do all this in a minute—but first you'll need to get a sense of what the job involves.

Here's what we need to do:

- 1 Create a new BirthdayParty class**
Your new class will need to calculate the costs, deal with decorations, and check the size of the writing on the cake.
- 2 Add a TabControl to your form**
Each tab on the form is a lot like the GroupBox control you used to choose which guy placed the bet in the Betting Parlor lab. Just click on the tab you want to display, and drag controls into it.
- 3 Label the first tab and move the Dinner Party controls onto it**
You'll drag each of the controls that handle the dinner party into the new tab. They'll work exactly like before, but they'll only be displayed when the dinner party tab is selected.
- 4 Label the second tab and add new Birthday Party controls onto it**
You'll design the interface for handling birthday parties just like you did for the dinner parties.
- 5 Wire your birthday party class up to the controls**
Now all you need to do is add a BirthdayParty reference to the form's fields, and add the code to each of your new controls to so that it uses its methods and properties.

BirthdayParty
NumberOfPeople CostOfDecorations CakeSize CakeWriting
CalculateCostOfDecorations() CalculateCost()

there are no Dumb Questions

Q: Why can't we just create a new instance of DinnerParty, like Mike did when he wanted to compare three routes in his navigation program?

A: Because if you created another instance of the DinnerParty class, you'd only be able to use it to plan extra dinner parties. Two instances of the same class can be really useful if you need to manage two different pieces of the same kind of data. But if you need to store different kinds of data, you'll need different classes to do it.

Q: How do I know what to put in the new class?

A: Before you can start building a class, you need to know what problem it's supposed to solve. That's why you had to talk to Kathleen—she's going to be using the program. Good thing you took a lot of notes! You can come up with your class's methods, fields, and properties by thinking about its behavior (what it *needs to do*) and its state (what it *needs to know*).



Exercise

Add birthday parties to Kathleen's party planning program.

Make sure you use decimal as the type for the fields and properties that hold currency.

1 Add the new BirthdayParty class to your program

You already know how you'll handle the NumberOfPeople property and the CostOfDecorations methods—they're just like their counterparts in DinnerParty. Start by creating your new class and adding those. Then add the rest of the behavior:

BirthdayParty
NumberOfPeople CostOfDecorations CakeSize CakeWriting
CalculateCostOfDecorations() CalculateCost()

If the cake writing is too long for the cake, the set accessor cuts the backing field down to size. So you'll need to make sure to reload the text into the text box every time the text changes or the number of people changes (in case there's a long string and she cuts down to a smaller cake).

- ★ Add a public int field called CakeSize. Make a private method called CalculateCakeSize() that sets CakeSize to either 8 or 16 depending on the number of people. You'll need to call it from the constructor and the NumberOfPeople set accessor.
- ★ You'll need a CakeWriting string property to hold the writing on the cake. We'll give you the code for this one.
- ★ The CakeWriting set accessor checks CakeSize because different sizes of cake can hold different numbers of letters. Then it uses value.Length to check how long the string is. If it's too long, instead of setting the private field, the set accessor pops up a message box that says, "Too many letters for a 16-inch cake" (or 8-inch cake).
- ★ Every string has a **Substring()** method that returns a portion of the string. CakeWriting uses it to cut the size of the cake writing down—if the number of people changes and reduces the cake size, you'll need to cut down the string, too.
- ★ Finally, add the CalculateCost() method. But instead of taking the decoration cost and adding the cost of beverages (which is what happens in DinnerParty), it'll add the cost of the cake.

We don't want any other methods changing the value of CakeWriting.

Click on the tabs to switch between them. Use the TabCollection property to change the text for each tab. Click the "..." button next to it and select each tab's Text property.

2 Update the form to add tabs

Drag a TabControl out of the toolbox and onto your form, and resize it so it takes up the entire form. Change the text of each tab using the TabPages property: a "..." button shows up in the Properties Window next to the property. When you click it, the IDE pops up a window that lets you edit the properties of each tab. Set the Text property of the tabs to "Dinner Party" and "Birthday Party".

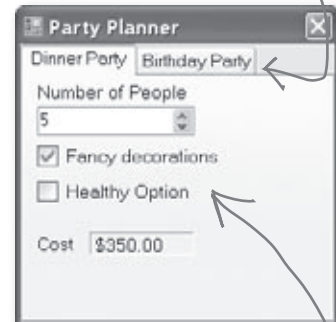

3 Name the first tab and move the Dinner Party controls onto it

You'll drag the each of the controls that handle the dinner party into the new tab. They'll work exactly like they do now, but they'll only be displayed when that tab is selected.

After you drag the Dinner Party controls onto the tab, they'll only be visible when the Dinner Party tab is selected.

4 Build the Birthday Party user interface

The Birthday Party GUI has a NumericUpDown control for the number of people, a CheckBox control for fancy decorations, and a Label control with a 3D border for the cost. Then you'll add a TextBox control for the cake writing.

This tab uses the NumericUpDown, CheckBox, and Label controls just like the Dinner Party tab does. Name them numberBirthday, fancyBirthday, and birthdayCost.

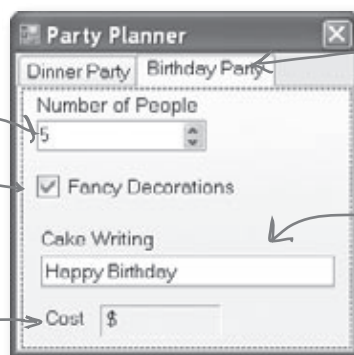

Click on the Birthday Party tab and add the new controls.

Add a TextBox control called cakeWriting for the writing on the cake (and a label above it so the user knows what it's for). Use its Text property to give it a default value of "Happy Birthday".

5 You'll need this property

Here's the code for the BirthdayParty.CakeWriting property—it'll come in handy:

```
private string cakeWriting = "";
public string CakeWriting {
    get { return this.cakeWriting; }
    set {
        int maxLength;
        if (CakeSize == 8)
            maxLength = 16;
        else
            maxLength = 40;
        if (value.Length > maxLength) {
            MessageBox.Show("Too many letters for a " + CakeSize + " inch cake");
            if (maxLength > this.cakeWriting.Length)
                maxLength = this.cakeWriting.Length;
            this.cakeWriting = cakeWriting.Substring(0, maxLength);
        }
        else
            this.cakeWriting = value;
    }
}
```

Did you notice how we left out some of the brackets? When you only have one statement in a code block, you don't need to add curly brackets around it.

This property is a little more complex than the ones you've seen before. It checks the cake size to see if it's too long for the cake, using the maxLength variable to store the maximum length. If it's too long, it gives an error message and then cuts the backing field down to the right size, so it can be reloaded into the text box.

Every string has a Substring() method that returns a portion of the string. This one cuts it down to the allowed length, so you'll need to reload the writing into the textbox when the text or cake size change.

6 Put it all together

All the pieces are there, now it's just a matter of writing a little code to make the controls work.

- ★ Add a BirthdayParty object to the form. Make sure you instantiate it.
- ★ Add code to the NumericUpDown control's event handler method to set the object's NumberOfPeople property.
- ★ Make the Fancy Decorations checkbox work.
- ★ Add a DisplayBirthdayPartyCost() method and add it to all of the event handlers so the cost label is updated automatically any time there's a change.

7 Run it

Make sure the program works the way it's supposed to. Check that it pops up a message box if the writing is too long for the cake. Make sure the price is always right. Once it's working, you're done!

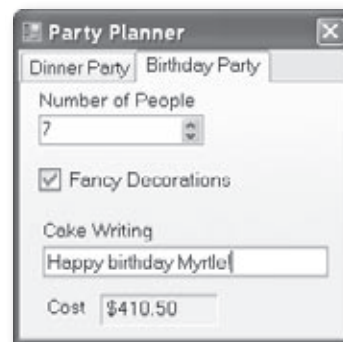

you are here ▶



Exercise Solution

Add birthday parties to Kathleen's party planning program.

```
public partial class Form1 : Form {
    DinnerParty dinnerParty;
    BirthdayParty birthdayParty;
    public Form1() {
        InitializeComponent();
        dinnerParty = new DinnerParty((int)numericUpDown1.Value,
            healthyBox.Checked, fancyBox.Checked);
        DisplayDinnerPartyCost();

        birthdayParty = new BirthdayParty((int)numberBirthday.Value,
            fancyBirthday.Checked, cakeWriting.Text);
        DisplayBirthdayPartyCost();
    }
}
```

The BirthdayParty instance is initialized in the form's constructor, just like the instance of DinnerParty.

// The fancyBox, healthyBox, and numericUpDown1 event handlers and // the DisplayDinnerCost() method are identical to the ones in the // Dinner Party exercise at the end of Chapter 5.

```
private void numberBirthday_ValueChanged(object sender, EventArgs e) {
    birthdayParty.NumberOfPeople = (int)numberBirthday.Value;
    DisplayBirthdayPartyCost();
}
```

The CheckBox and NumericUpDown controls' event handlers are just like the ones for the dinner party.

```
private void fancyBirthday_CheckedChanged(object sender, EventArgs e) {
    birthdayParty.CalculateCostOfDecorations(fancyBirthday.Checked);
    DisplayBirthdayPartyCost();
}
```

```
private void cakeWriting_TextChanged(object sender, EventArgs e) {
    birthdayParty.CakeWriting = cakeWriting.Text;
    DisplayBirthdayPartyCost();
}
```

```
private void DisplayBirthdayPartyCost() {
    cakeWriting.Text = birthdayParty.CakeWriting;
    decimal cost = birthdayParty.CalculateCost();
    birthdayCost.Text = cost.ToString("c");
}
```

The way that the form handles the cake writing can be really simple because the BirthdayParty class is well encapsulated. All the form has to do is use its controls to set the properties on the object, and the object takes care of the rest.

All the intelligence for dealing with making sure the writing, the number of people, and the cake size are built into the NumberOfPeople and CakeWriting set accessors, so the form just has to set and display the values.

```
using System.Windows.Forms;
```

```
public class BirthdayParty {
```

```
    public const int CostOfFoodPerPerson = 25;
```

```
    public decimal CostOfDecorations = 0;
    private bool fancyDecorations;
    public int CakeSize;
```

When the BirthdayParty object is initialized, it needs to know the number of people, the fancy decorations and the writing on the cake, so it can start out with the right cake cost when CalculateCost() is called.

```
    public BirthdayParty(int numberOfPeople, bool fancyDecorations, string cakeWriting) {
        this.numberOfPeople = numberOfPeople;
        this.fancyDecorations = fancyDecorations;
        CalculateCakeSize();
        this.CakeWriting = cakeWriting;
        CalculateCostOfDecorations(fancyDecorations);
    }
```

The constructor's calling the set accessor to set the cake writing, in case the parameter is too long for the cake, so it's got to calculate the cake size first.

The constructor sets the properties and then runs the calculations.

```
    private void CalculateCakeSize() {
        if (NumberOfPeople <= 4)
            CakeSize = 8;
        else
            CakeSize = 16;
    }
```

The CalculateCakeSize() method sets the CakeSize field. It's called by the NumberOfPeople set accessor and the CalculateCost() method.

```
    private string cakeWriting = "";
```

```
    public string CakeWriting {
        get { return this.cakeWriting; }
        set {
            int maxLength;
            if (CakeSize == 8)
                maxLength = 16;
            else
                maxLength = 40;
            if (value.Length > maxLength) {
                MessageBox.Show("Too many letters for a " + CakeSize + " inch cake");
                if (maxLength > this.cakeWriting.Length)
                    maxLength = this.cakeWriting.Length;
                this.cakeWriting = cakeWriting.Substring(0, maxLength);
            }
            else
                this.cakeWriting = value;
        }
    }
}
```

The CakeWriting property makes sure that the cake's writing is never too long for the cake size. Its set accessor checks the cake size, then uses the backing fields Length property to make sure it's not too long. If it is, it cuts the string down to the right size.



Exercise Solution

Add birthday parties to Kathleen's party planning program.

We're using decimal because we're dealing with prices and currency.

```
public decimal CalculateCost() {
    decimal TotalCost = CostOfDecorations + (CostOfFoodPerPerson * NumberOfPeople);
    decimal CakeCost;
    if (CakeSize == 8)
        CakeCost = 40M + CakeWriting.Length * .25M;
    else
        CakeCost = 75M + CakeWriting.Length * .25M;
    return TotalCost + CakeCost;
}
```

The CalculateCost() method is a lot like the one from DinnerParty, except that it adds the cost of the cake instead of the Healthy Choice option.

```
private int numberOfPeople;
public int NumberOfPeople {
    get { return numberOfPeople; }
    set {
        numberOfPeople = value;
        CalculateCostOfDecorations(fancyDecorations);
        CalculateCakeSize();
        this.CakeWriting = cakeWriting;
    }
}
```

Making the CakeWriting method cut down the size of the cake is only half of the solution. The other half is making sure that the CakeWriting set accessor gets run every time the number of people changes.

This method is just like the one in the DinnerParty class.

```
public void CalculateCostOfDecorations(bool fancy) {
    fancyDecorations = fancy;
    if (fancy)
        CostOfDecorations = (NumberOfPeople * 15.00M) + 50M;
    else
        CostOfDecorations = (NumberOfPeople * 7.50M) + 30M;
}
```

So when the number of people changes, the class first recalculates the cake size, and then it uses its set accessor for CakeWriting to cut the text down—so if a 10-person party turns into a 4-person one, their 36-letter message will be cut down to one that'll fit on the smaller cake.

Curly brackets are optional for single-line blocks

A lot of times you'll have an if statement or while loop that's just got a single statement inside its block. When that happens a lot, you can end up with a whole lot of curly brackets—and that can be a real eyesore! C# helps you avoid that problem by letting you drop the curly brackets if there's just one statement. So this is perfectly valid syntax for a loop and an if statement:

```
for (int i = 0; i < 10; i++)
```

```
    DoTheJob(i);
```

```
if (myValue == 36)
```

```
    myValue *= 5;
```

One more thing... can you add a \$100 fee for parties over 12?

Kathleen's gotten so much business using your program that she can afford to charge a little more for some of her larger clients. So what would it take to change your program to add in the extra charge?

- ★ Change the `DinnerParty.CalculateCost()` to check `NumberOfPeople` and add \$100 to the return value if it's over 12.
- ★ Do the exact same thing for `BirthdayParty.CalculateCost()`.

Take a minute and think about how you'd add a fee to both the `DinnerParty` and `BirthdayParty` class. What code would you write? Where would it have to go?

Easy enough... but what happens if there are three similar classes? Or four? Or twelve? And what if you had to maintain that code and make more changes later? What if you had to make the *same exact change* to five or six *closely related* classes?



Wow, I'd have to write the same code over and over again. That's a really inefficient way to work. There's got to be a better way!

You're right! Having the same code repeated in different classes is inefficient and error-prone. Lucky for us, C# gives us a better way to build classes that are related to each other, and share behavior: *inheritance*.

When your classes use inheritance, you only need to write your code once

It's no coincidence that your `DinnerParty` and `BirthdayParty` classes have a lot of the same code. When you write C# programs, you often create classes that represent things in the real world—and those things are usually related to each other. Your classes have **similar code** because the things they represent in the real world—a birthday party and a dinner party—have **similar behaviors**.

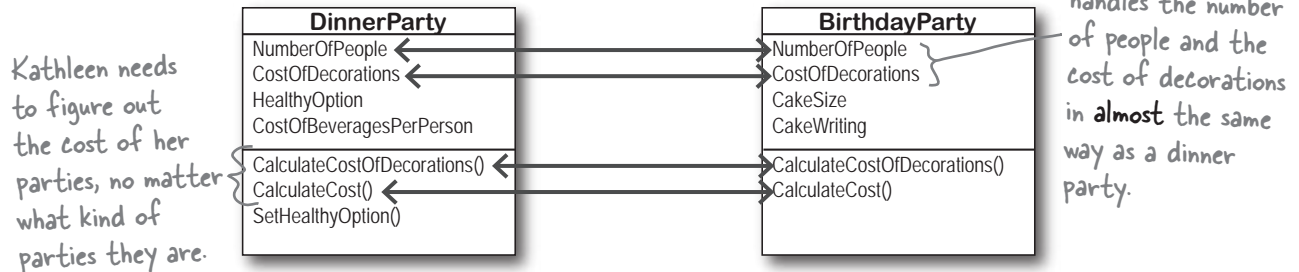

Dinner parties and birthday parties are both parties

When you have two classes that are more specific cases of something more general, you can set them up to **inherit** from the same class. When you do that, each of them is a **subclass** of the same **base class**.

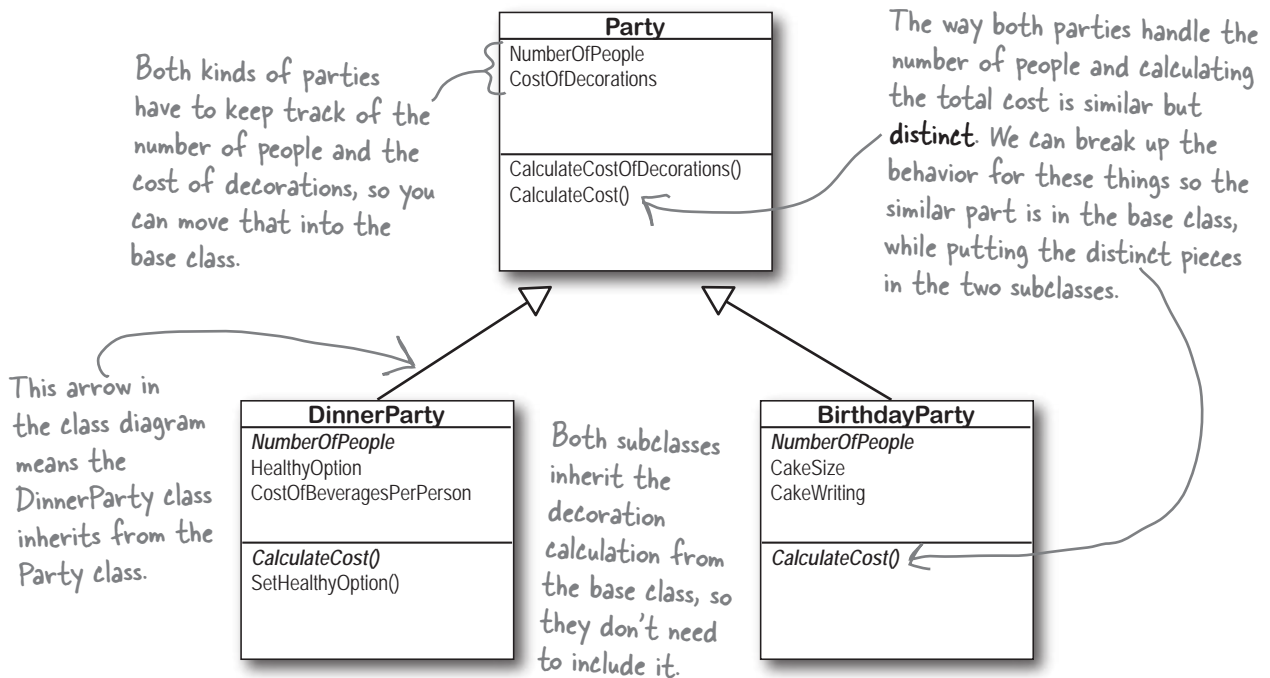

Build up your class model by starting general and getting more specific

C# programs use inheritance because it mimics the relationship that the things they model have in the real world. Real-world things are often in a **hierarchy** that goes from more general to more specific, and your programs have their own **class hierarchy** that does the same thing. In your class model, classes further down in the hierarchy **inherit** from those above it.



If you have a recipe that calls for cheddar cheese, then you can use aged Vermont cheddar. But if it specifically needs aged Vermont, then you can't just use any cheddar—you need that specific cheese.

in-her-it, verb.

to derive an attribute from one's parents or ancestors. *She wanted the baby to **inherit** her big brown eyes, and not her husband's beady blue ones.*

How would you design a zoo simulator?

Lions and tigers and bears... oh my! Also, hippos, wolves, and the occasional cat. Your job is to design a program that simulates a zoo. (Don't get too excited—we're not going to actually build the code, just design the classes to represent the animals.)

We've been given a list of some of the animals that will be in the program, but not all of them. We know that each animal will be represented by an object, and that the objects will move around in the simulator, doing whatever it is that each particular animal is programmed to do.

More importantly, we want the program to be easy for other programmers to maintain, which means they'll need to be able to add their own classes later on if they want to add new animals to the simulator.

So what's the first step? Well, before we can talk about **specific** animals, we need to figure out the **general** things they have in common, abstract characteristics that **all** animals have. Then we can build those characteristics into a class that all animal classes can inherit from.

1 Look for things the animals have in common

Take a look at these six animals. What do a lion, a hippo, a tiger, a cat, a wolf, and a dalmatian have in common? How are they related? You'll need to figure out their relationships so you can come up with a class model that includes all of them.



Use inheritance to avoid duplicate code in subclasses

You've already got a good idea that duplicate code sucks. It's hard to maintain, and always leads to headaches down the road. So let's choose fields and methods for an `Animal` base class that you **only have to write once**, so each of the animal subclasses can inherit from them. Let's start with the public fields:

- ★ `Picture`: an image that you can put into a `PictureBox`.
- ★ `Food`: the type of food this animal eats. Right now, there can be only two values: meat or grass.
- ★ `Hunger`: an `int` representing the hunger level of the animal. It changes depending on when (and how much) the animal eats.
- ★ `Boundaries`: a reference to a class that stores the height, width and location of the pen that the animal will roam around in.
- ★ `Location`: the X and Y coordinates where the animal's standing.

And the `Animal` class has four methods the animals can inherit:

- ★ `MakeNoise()`: a method to let the animal make a sound.
- ★ `Eat()`: behavior for when the animal encounters its preferred food.
- ★ `Sleep()`: a method to make the animal lie down and take a nap.
- ★ `Roam()`: the animals like to wander around their pens in the zoo.

2 Build a base class to give the animals everything they have in common

The fields, properties, and methods in the base class will give all of the animals that inherit from it a common state and behavior. They're all animals, so it makes sense to call the base class `Animal`.

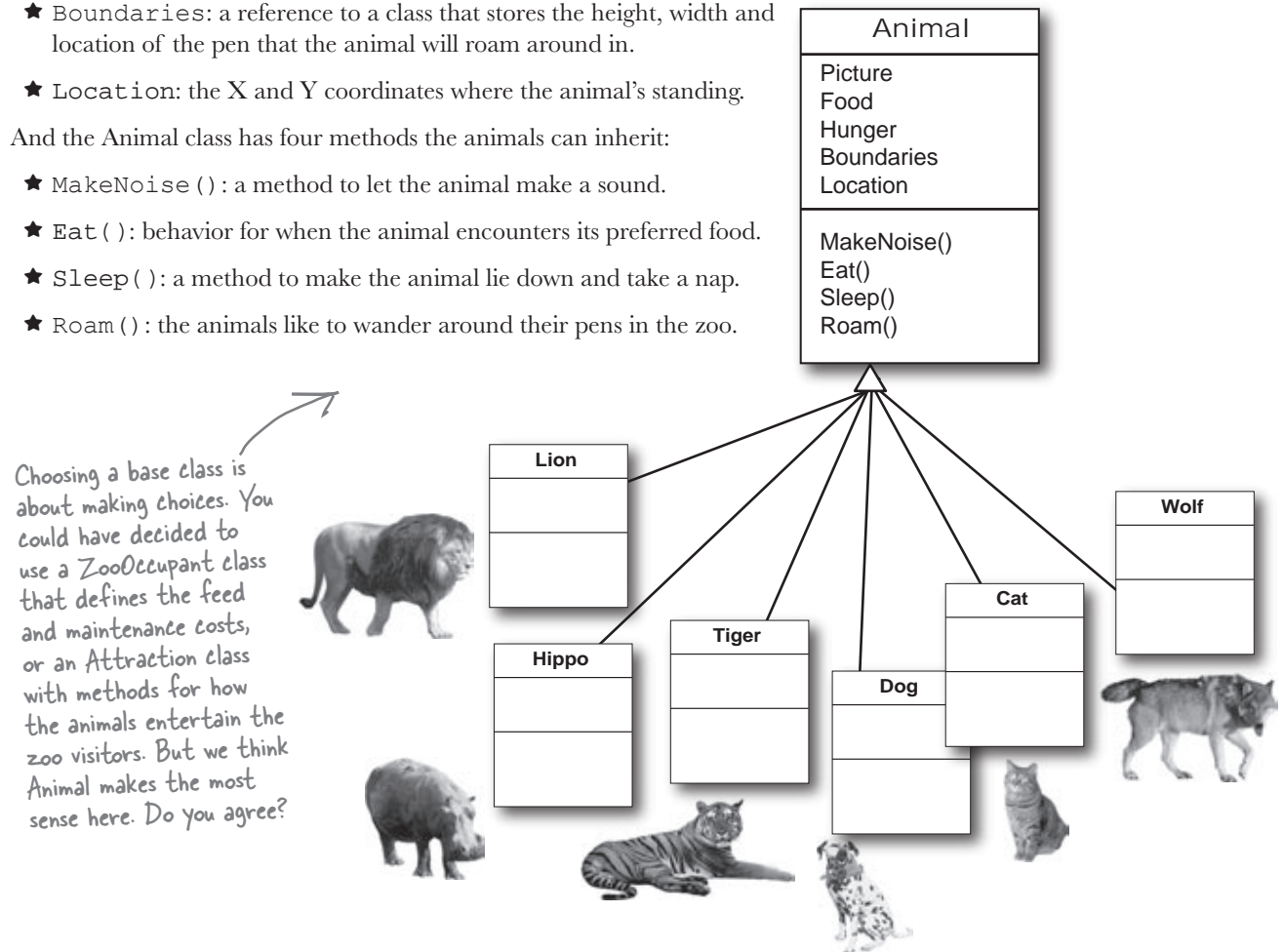

Different animals make different noises

Lions roar, dogs bark, and as far as *we* know hippos don't make any sound at all. Each of the classes that inherit from `Animal` will have a `MakeNoise()` method, but each of those methods will work a different way and will have different code. When a subclass changes the behavior of one of the methods that it inherited, we say that it **overrides** the method.

Think about what you need to override

When a subclass changes the behavior of a method it inherited, we call it **overriding**. Every animal needs to eat. But a dog might take little bites of meat, while a hippo eats huge mouthfuls of grass. So what would the code for that behavior look like? Both the dog and the hippo would override the `Eat()` method. The hippo's method would have it consume, say, 20 pounds of hay each time it was called. The dog's `Eat()` method, on the other hand, would reduce the zoo's food supply by one 12-ounce can of dog food.

So when you've got a subclass that inherits from a base class, it **must** inherit all of the base class's behaviors... but you can **modify** them in the subclass so they're not performed exactly the same way. That's what overriding is all about.

Animal
Picture
Food
Hunger
Boundaries
Location
MakeNoise()
Eat()
Sleep()
Roam()

Grass is yummy! I could go for a good pile of hay right now.



I beg to differ.



Just because a property or a method is in the `Animal` base class, that doesn't mean every subclass has to use it the same way... or at all!

3

Figure out what each animal does that the `Animal` class does differently—or not at all

What does each type of animal do that all the other animals don't? Dogs eat dog food, so the dog's `Eat()` method will need to override the `Animal.Eat()` method. Hippos swim, so a hippo will have a `Swim()` method that isn't in the `Animal` class at all.



We already know that some animals will override the `MakeNoise()` and `Eat()` methods. Which animals will override `Sleep()` or `Roam()`? Will any of them? What about the properties—which animals will override some properties?

Think about how to group the animals

Aged Vermont cheddar is a kind of cheese, which is a dairy product, which is a kind of food, and a good class model for food would represent that. Lucky for us, C# give us an easy way to do it. You can create a chain of classes that inherit from each other, starting with the topmost base class and working down. So you could have a Food class, with a subclass called DairyProduct that serves as the base class for Cheese, which has a subclass called Cheddar, which is what AgedVermontCheddar inherits from.

4 Look for classes that have a lot in common

Don't dogs and wolves seem pretty similar? They're both canines, and it's a good bet that if you look at their behavior they have a lot in common. They probably eat the same food and sleep the same way. What about domestic cats, tigers, and lions? It turns out all three of them move around their habitats in exactly the same way. It's a good bet that you'll be able to have a Feline class that lives between Animal and those three cat classes that can help prevent duplicate code between them.

The subclasses inherit all four methods from Animal, but we're only having them override MakeNoise() and Eat().

That's why we only show those two methods in the class diagrams.

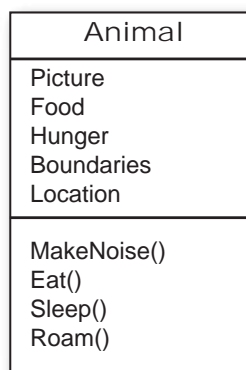

There's a pretty good chance that we'll be able to add a Canine class that the dogs and wolves both inherit from.

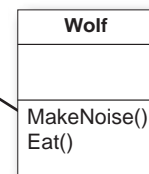
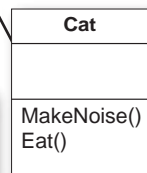
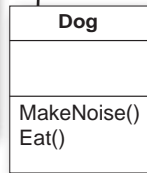
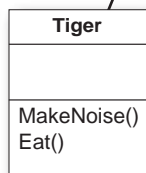
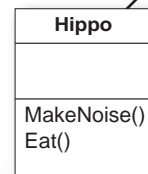
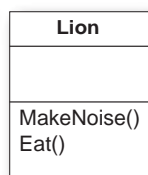

Create the class hierarchy

When you create your classes so that there's a base class at the top with subclasses below it, and those subclasses have their own subclasses that inherit from them, what you've built is called a **class hierarchy**. This is about more than just avoiding duplicate code, although that is certainly a great benefit of a sensible hierarchy. But when it comes down to it, the biggest benefit you'll get is that your code becomes really easy to understand and maintain. When you're looking at the zoo simulator code, when you see a method or property defined in the Feline class, then you *immediately know* that you're looking at something that all of the cats share. Your hierarchy becomes a map that helps you find your way through your program.

5 Finish your class hierarchy

Now that you know how you'll organize the animals, you can add the Feline and Canine classes.

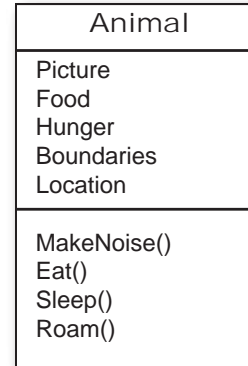

Since Feline overrides Roam(), anything that inherits from it gets its new Roam() and not the one in Animal.

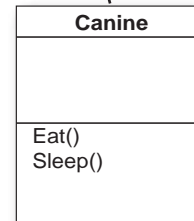
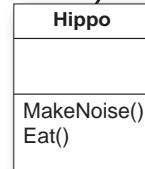
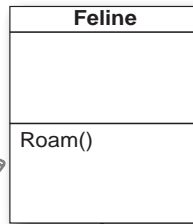
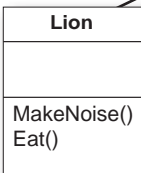

The three cats roam the same way, so they share an inherited Roam() method. But each one still eats and makes noise differently, so they'll all override Eat() and MakeNoise() that they inherited from Animal.

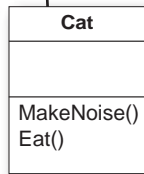
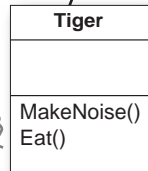

Our wolves and dogs eat the same way, so we moved their common Eat() method up to the Canine class.

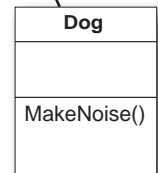
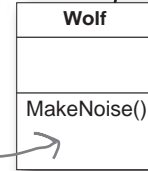

Every subclass extends its base class

You're not limited to the methods that a subclass inherits from its base class... but you already know that! After all, you've been building your own classes all along. When you add inheritance to a class, what you're doing is taking the class you've already built and **extending** it by adding all of the fields, properties, and methods in the base class. So if you wanted to add a `Fetch()` method to the dog, that's perfectly normal. It won't inherit or override anything—only the dog will have that method, and it won't end up in `Wolf`, `Canine`, `Animal`, `Hippo`, or any other class.

hi-er-ar-chy, noun.
an arrangement or classification in which groups or things are ranked one above the other. *The president of Dynamco had worked his way up from the mailroom to the top of the corporate **hierarchy**.*

makes a new *Dog* object

```
Dog spot = new Dog();
```

calls the version in *Dog*

```
spot.MakeNoise();
```

calls the version in *Animal*

```
spot.Roam();
```

calls the version in *Canine*

```
spot.Eat();
```

calls the version in *Canine*

```
spot.Sleep();
```

calls the version in *Dog*

```
spot.Fetch();
```

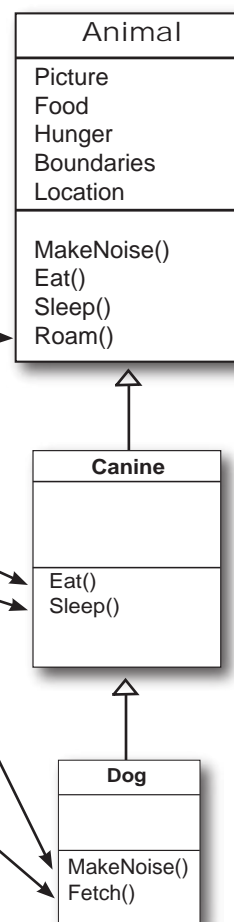

C# always calls the most specific method

If you tell your dog object to roam, there's only one method that can be called—the one in the `Animal` class. But what about telling your dog to make noise? Which `MakeNoise()` is called?

Well, it's not too hard to figure it out. A method in the `Dog` class tells you how dogs do that thing. If it's in the `Canine` class, it's telling you how all canines do it. And if it's in `Animal`, then it's a description of that behavior that's so general that it applies to every single animal. So if you ask your dog to make a noise, first C# will look inside the dog class to find the behavior that applies *specifically* to dogs. If `Dog` didn't have one, it'd then check `Canine`, and after that it'd check `Animal`.



Use a colon to inherit from a base class

When you're writing a class, you use a **colon (:)** to have it inherit from a base class. That makes it a subclass, and gives it **all of the fields, properties, and methods** of the class it inherits from.

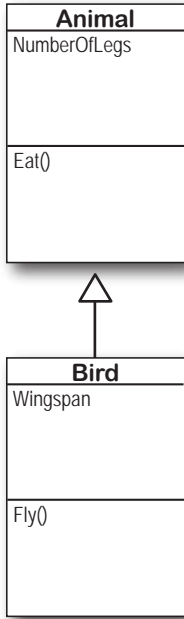

```
public class Animal
{
    public int NumberOfLegs;
    public void Eat() {
        // code to make the animal eat
    }
}
```

The Bird class uses a colon to inherit from the Animal class. This means that it inherits all of the fields, properties, and methods from Animal.

```
public class Bird : Animal
{
    public double Wingspan;
    public void Fly() {
        // code to make the bird fly
    }
}
```

You extend a class by adding a colon to the end of the class declaration, followed by the base class to inherit from.

tweety is an instance of Bird, so it's got the Bird methods and fields as usual.

```
public button1_Click(object sender, EventArgs e) {
    Bird tweety = new Bird();
    tweety.Wingspan = 7.5;
    tweety.Fly();
    tweety.NumberOfLegs = 2;
    tweety.Eat();
}
```

Since the Bird class inherits from Animal, every instance of Bird also has the fields and methods defined in the Animal class.

there are no Dumb Questions

Q: Why does the arrow point up, from the subclass to the base class? Wouldn't the diagram look better with the arrow pointing down instead?

A: It might look better, but it wouldn't be as accurate. When you set up a class to inherit from another one, you build that relationship into the subclass—the base class remains the same. And that makes sense when you think about it from the perspective of the base class.

Its behavior is completely unchanged when you add a class that inherits from it. The base class isn't even aware of this new class that inherited from it. Its methods, fields, and properties remain entirely intact. But the subclass definitely changes its behavior. Every instance of the subclass automatically gets all of the properties, fields, and methods from the base class, and it all happens just by adding a colon. That's why you draw the arrow on your diagram so that it's part of the subclass, and points to the base class that it inherits from.



Take a look at these class models and declarations, and then circle the statements that won't work.

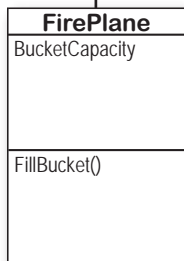
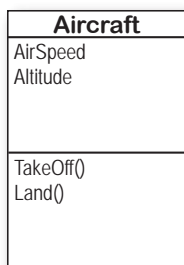

```
public class Aircraft {
    public double AirSpeed;
    public double Altitude;
    public void TakeOff() { ... };
    public void Land() { ... };
}

public class FirePlane : Aircraft {
    public double BucketCapacity;
    public void FillBucket() { ... };
}
```

```
public void FireFightingMission() {
    FirePlane myFirePlane = new FirePlane();
    new FirePlane.BucketCapacity = 500;
    Aircraft.Altitude = 0;
    myFirePlane.TakeOff();
    myFirePlane.AirSpeed = 192.5;
    myFirePlane.FillBucket();
    Aircraft.Land();
}
```

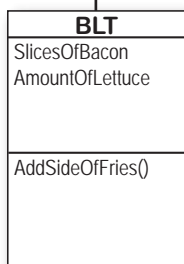

```
public class Sandwich {
    public boolean Toasted;
    public int SlicesOfBread;
    public int CountCalories() { ... }
}

public class BLT : Sandwich {
    public int SlicesOfBacon;
    public int AmountOfLettuce;
    public int AddSideOfFries() { ... }
}
```

```
public BLT OrderMyBLT() {
    BLT mySandwich = new BLT();
    BLT.Toasted = true;
    Sandwich.SlicesOfBread = 3;
    mySandwich.AddSideOfFries();
    mySandwich.SlicesOfBacon += 5;
    MessageBox.Show("My sandwich has "
        + mySandwich.CountCalories + "calories.");
    return mySandwich;
}
```

Sharpen your pencil Solution

Take a look at these class models and declarations, and then circle the statements that won't work.

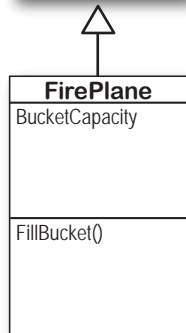
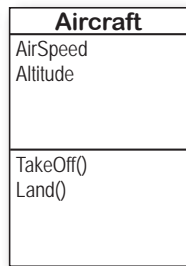

```
public class Aircraft {
    public double AirSpeed;
    public double Altitude;
    public void TakeOff() { ... };
    public void Land() { ... };
}

public class FirePlane : Aircraft {
    public double BucketCapacity;
    public void FillBucket() { ... };
}

public void FireFightingMission() {
    FirePlane myFirePlane = new FirePlane();
    new FirePlane.BucketCapacity = 500;
    Aircraft.Altitude = 0;
    myFirePlane.TakeOff();
    myFirePlane.AirSpeed = 192.5;
    myFirePlane.FillBucket();
    Aircraft.Land();
}
```

That's not how you use the new keyword.

These statements all use the class names instead of the name of the instance, myFirePlane.

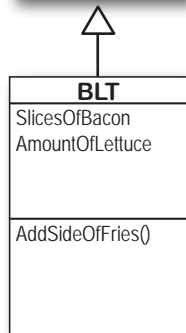
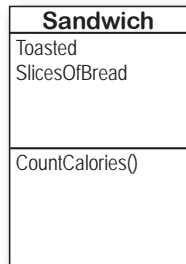

```
public class Sandwich {
    public boolean Toasted;
    public int SlicesOfBread;
    public int CountCalories() { ... }
}

public class BLT : Sandwich {
    public int SlicesOfBacon;
    public int AmountOfLettuce;
    public int AddSideOfFries() { ... }
}

public BLT OrderMyBLT() {
    BLT mySandwich = new BLT();
    BLT.Toasted = true;
    Sandwich.SlicesOfBread = 3;
    mySandwich.AddSideOfFries();
    mySandwich.SlicesOfBacon += 5;
    MessageBox.Show("My sandwich has "
        + mySandwich.CountCalories + "calories.");
    return mySandwich;
}
```

These properties are part of the instance, but the statements are trying to call them incorrectly using the class names.

CountCalories is a method, but this statement doesn't include the parentheses () after the call to the method.

We know that inheritance adds the base class fields, properties, and methods to the subclass...

Inheritance is simple when your subclass needs to inherit **all** of the base class methods, properties, and fields.

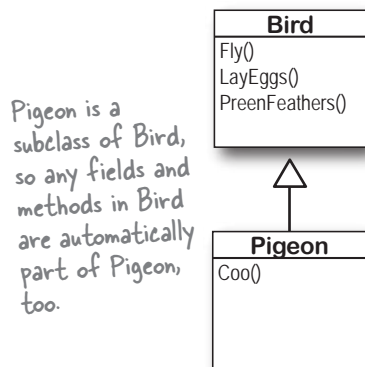

```

public class Bird {
    public void Fly() {
        // here's the code to make the bird fly
    }

    public void LayEggs() { ... };

    public void PreenFeathers() { ... };
}
  
```

```

public class Pigeon : Bird {
    public void Coo() { ... }
}
  
```

```

public class Penguin : Bird {
    public void Swim() { ... }
}
  
```

... but some birds don't fly!

What do you do if your base class has a method that your subclass needs to **modify**?

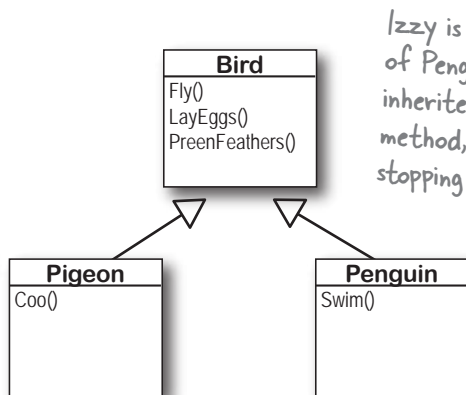

Izzy is an instance of Penguin. Since it inherited the Fly() method, there's nothing stopping it from flying.

```

public void BirdSimulator() {
    Pigeon Harriet = new Pigeon();
    Penguin Izzy = new Penguin();

    Harriet.Fly();
    Harriet.Coo();
    Izzy.Fly();
}
  
```

Both Pigeon and Penguin inherit from Bird, so they both get the Fly(), LayEggs(), and PreenFeathers() methods.

Penguin objects shouldn't be able to fly! But if the Penguin class inherits from Bird, then you'll have penguins flying all over the place. So what do we do?

Pigeons fly, lay eggs, and preen their feathers, so there's no problem with the Pigeon class inheriting from Bird.



If this were your Bird Simulator code, what would you do to keep the penguins from flying?

A subclass can override methods to change or replace methods it inherited

Sometimes you've got a subclass that you'd like to inherit *most* of the behaviors from the base class, but *not all of them*.

When you want to change the behaviors that a class has inherited, you can **override** the methods.

1 Add the virtual keyword to the method in the base class

A subclass can only override a method if it's marked with the **virtual** keyword, which tells C# to allow the subclass to override methods.

```
public class Bird {
    public virtual void Fly() {
        // code to make the bird fly
    }
}
```

Adding the virtual keyword to the Fly() method tells C# that a subclass is allowed to override it.

2 Add a method with the same name to the derived class

You'll need to have exactly the same signature—meaning the same return value and parameters—and you'll need to use the **override** keyword in the declaration.

```
public class Penguin : Bird {
    public override void Fly() {
        MessageBox.Show("Penguins can't fly!")
    }
}
```

To override the Fly() method, add an identical method to the subclass and use the override keyword.

When you override a method, your new method needs to have exactly the same signature as the method in the base class it's overriding. In this case, that means it needs to be called Fly, return void, and have no parameters.

Use the override keyword to add a method to your subclass that replaces one that it inherited. Before you can override a method, you need to mark it virtual in the base class.

Any place where you can use a base class, you can use one of its subclasses instead

One of the most useful things you can do with inheritance is use a subclass in place of the base class it inherits from. So if your `Recipe()` method takes a `Cheese` object and you've got an `AgedVermontCheddar` class that inherits from `Cheese`, then you can pass an instance of `AgedVermontCheddar` to the `Recipe()` method. `Recipe()` only has access to the fields, properties, and methods that are part of the `Cheese` class, though—it doesn't have access to anything specific to `AgedVermontCheddar`.

- Let's say we have a method to analyze sandwich objects:

```
public void SandwichAnalyzer(Sandwich specimen) {
    int calories = specimen.CountCalories();
    UpdateDietPlan(calories);
    PerformBreadCalculations(specimen.SlicesOfBread, specimen.Toasted);
}
```

- You could pass a sandwich to the method—but you could also pass a BLT. Since a BLT is a *kind* of sandwich, we set it up so that it inherits from the `Sandwich` class.

```
public button1_Click(object sender, EventArgs e) {
    BLT myBLT = new BLT();
    SandwichAnalyzer(myBLT);
}
```

We'll talk about this more in the next chapter!

- You can always move **down** the class diagram—a reference variable can always be set equal to an instance of one of its subclasses. But you can't move **up** the class diagram.

```
public button2_Click(object sender, EventArgs e) {
    Sandwich mySandwich = new Sandwich();
    BLT myBLT = new BLT();
    Sandwich someRandomSandwich = myBLT;
    BLT anotherBLT = mySandwich; // <--- THIS WON'T COMPILE!!!
}
```

You can assign `myBLT` to any `Sandwich` variable because a BLT is a kind of sandwich.

But you can't assign `mySandwich` to a BLT variable, because not every sandwich is a BLT! That's why this last line will cause an error.

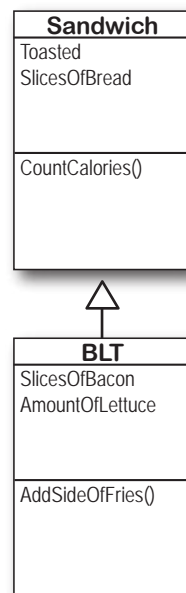



Mixed Messages

```
a = 6;
b = 5;
a = 5;
```

56
11
65

A short C# program is listed below. One block of the program is missing! Your challenge is to match the candidate block of code (on the left), with the output—what’s in the messagebox that the program pops up—that you’d see if the block were inserted. Not all the lines of output will be used, and some of the lines of output might be used more than once. Draw lines connecting the candidate blocks of code with their matching output.

Instructions:

1. Fill in the four blanks in the code.
2. Match the code candidates to the output.

```
public class A {
    public int ivar = 7;
    public _____ string m1() {
        return "A's m1, ";
    }
    public string m2() {
        return "A's m2, ";
    }
    public _____ string m3() {
        return "A's m3, ";
    }
}

public class B : A {
    public _____ string m1() {
        return "B's m1, ";
    }
}
```

```
public class C : B {
    public _____ string m3() {
        return "C's m3, " + (ivar + 6);
    }
}

public class Mixed5 {
    public static void Main(string[] args) {
        A a = new A();
        B b = new B();
        C c = new C();
        A a2 = new C();
        string q = "";

        _____

        System.Windows.Forms.MessageBox.Show(q);
    }
}
```

Here's the entry point for the program—it doesn't show a form, it just pops up a messagebox.

Hint: Think really hard about what this line really means.

candidate code goes here (three lines)

- code candidates:**
- q += b.m1();
 - q += c.m2();
 - q += a.m3();

 - q += c.m1();
 - q += c.m2();
 - q += c.m3();

 - q += a.m1();
 - q += b.m2();
 - q += c.m3();

 - q += a2.m1();
 - q += a2.m2();
 - q += a2.m3();

output:

- A's m1, A's m2, C's m3, 6
- B's m1, A's m2, A's m3,
- A's m1, B's m2, A's m3,
- B's m1, A's m2, C's m3, 13
- B's m1, C's m2, A's m3,
- B's m1, A's m2, C's m3, 6
- A's m1, A's m2, C's m3, 13

(Don't just type this into the IDE—you'll learn a lot more if you figure this out on paper!)



Pool Puzzle

Your **job** is to take code snippets from the pool and place them into the blank lines in the code. You may use the same snippet more than once, and you might not need to use all the snippets. Your **goal** is to make a set of classes that will compile and run together as a program. Don't be fooled—this one's harder than it looks.

```
public class Rowboat .....{
    public ..... rowTheBoat() {
        return "stroke natasha";
    }
}

public class ..... {
    private int ..... ;
    ..... void.....( ..... ) {
        length = len;
    }
    public int getLength() {
        ..... ;
    }
    public ..... move() {
        return ".....";
    }
}
```

```
public class TestBoats {
    ..... Main(){
        ..... xyz = "";
        ..... b1 = new Boat();
        Sailboat b2 = new ..... ();
        Rowboat ..... = new Rowboat ();
        b2.setLength(32);
        xyz = b1. .... ();
        xyz += b3. .... ();
        xyz += .....move();
        System.Windows.Forms.MessageBox.Show(xyz);
    }
}

public class ..... : Boat {
    public ..... () {
        return ".....";
    }
}
```

Hint: This is the entry point for the program.

OUTPUT:

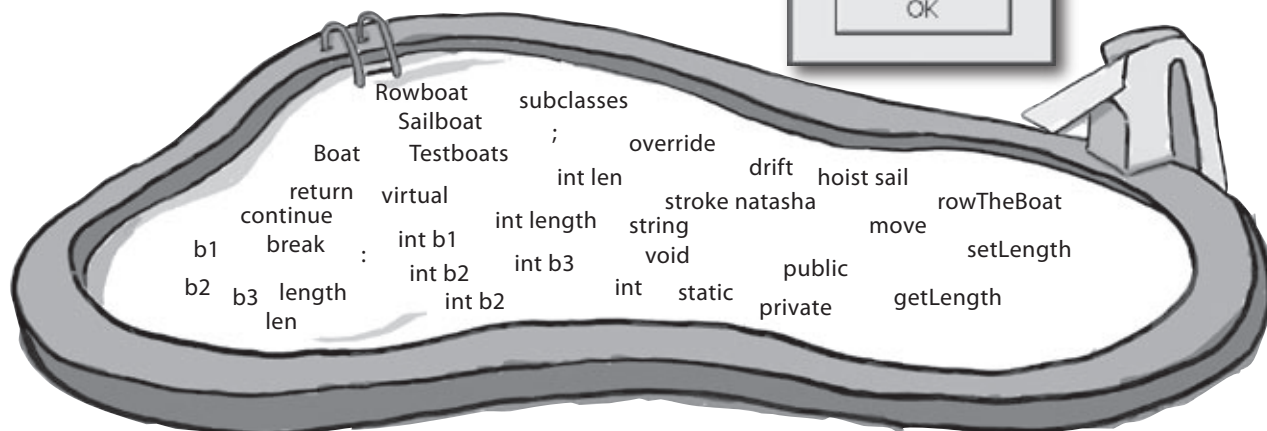



Exercise Solution

Mixed Messages

```
a = 6;
b = 5;
a = 5;
```

→ 56
→ 11
→ 65

```
public class A {
    public virtual string m1() {
        ...
    }
    public virtual string m3() {
        ...
    }
}

public class B : A {
    public override string m1() {
        ...
    }
}

public class C : B {
    public override string m3() {
        ...
    }
}
```

You can always substitute a reference to a subclass in place of a base class. In other words, you can always use something more specific in place of something more general—so if you’ve got a line of code that asks for a Canine, you can send it a reference to a Dog. So this line of code:

```
A a2 = new C();
```

means that you’re instantiating a new C object, and then creating an A reference called a2 and pointing it at that object. Names like A, a2 and C make for a good puzzle, but they’re a little hard to understand. Here are a few lines that follow the same pattern, but have names that you can understand:

```
Sandwich mySandwich = new BLT();
Cheese ingredient = new AgedVermontCheddar();
Songbird tweety = new NorthernMockingbird();
```

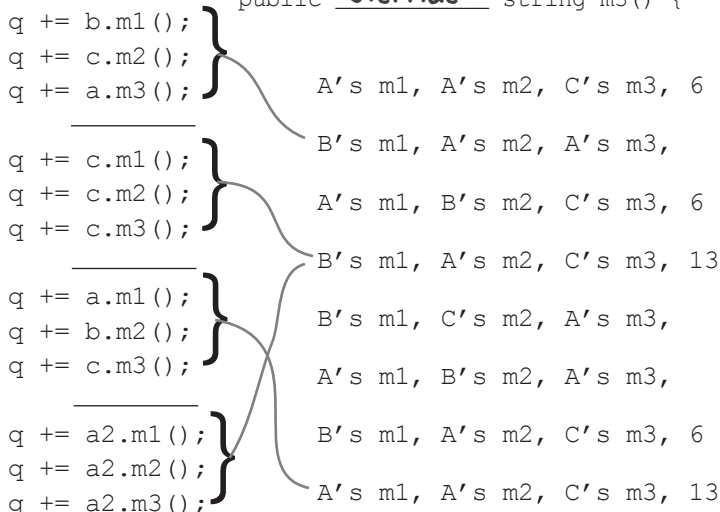

Pool Puzzle Solution



```
public class Rowboat : Boat {
    public string rowTheBoat() {
        return "stroke natasha";
    }
}

public class Boat {
    private int length;
    public void setLength(int len) {
        length = len;
    }
    public int getLength() {
        return length;
    }
    public virtual string move() {
        return "...drift...";
    }
}
```

```
public class TestBoats {
    public static void Main() {
        string xyz = "";
        Boat b1 = new Boat();
        Sailboat b2 = new Sailboat();
        Rowboat b3 = new Rowboat();

        b2.setLength(32);
        xyz = b1.move();
        xyz += b3.move();
        xyz += b2.move();

        System.Windows.Forms.MessageBox.Show(xyz);
    }
}

public class Sailboat : Boat {
    public override string move() {
        return "hoist sail";
    }
}
```

there are no Dumb Questions

Q: About the entry point that you pointed out in the Pool Puzzle—does this mean I can have a program that doesn't have a Form1 form?

A: Yes. When you create a new Windows Application project, the IDE creates all the files for that project for you, including Program.cs (which contains a static class with an entry point) and Form1.cs (which contains an empty form called Form1).

Try this: instead of creating a new Windows Application project, create an empty project by selecting "Empty Project" instead of "Windows Application" when you create a new project in the IDE. Then add a class file to it in the Solution Explorer and type in everything in the Pool Puzzle solution. Since your program uses a messagebox, you need to add a **reference** by right-clicking on "References" in the Solution Explorer, selecting "Add Reference", and choosing System.Windows.Forms from the .NET tab. (That's another thing the IDE does for you automatically when you create a Windows Application.) Finally, select "Properties" from the Project menu and choose the "Windows Application" output type.

Now run it... you'll see the results! Congratulations, you just created a C# program from scratch.

↑
Flip back to the beginning of Chapter 2 if you need a refresher on Main() and the entry point!

Q: Can I inherit from the class that contains the entry point?

A: Yes. The entry point *must* be a static method, but that method *doesn't have to be* in a static class. (Remember, the `static` keyword means that the class can't be instantiated, but that its methods are available as soon as the program starts. So in the Pool Puzzle program, you can call `TestBoats.Main()` from any other method without declaring a reference variable or instantiating an object using a `new` statement.)

Q: I still don't get why they're called "virtual" methods—they seem real to me!

A: The name "virtual" has to do with how .NET handles the virtual methods behind the scenes. It uses something called a virtual method table (or `vtable`). That's a table that .NET uses to keep track of which methods are inherited and which ones have been overridden. Don't worry—you don't need to know how it works to use virtual methods!

Q: What did you mean by only being able to move up the class diagram but not being able to move down?

A: When you've got a diagram with one class that's above another one, the class that's higher up is more *abstract* than the one that's lower down. More specific or concrete classes (like `Shirt` or `Car`) inherit from more abstract ones (like `Clothing` or `Vehicle`). When you think about it that way, it's easy to see how if all you need is any vehicle, a car or van or motorcycle will do. But if you need a car, a motorcycle won't be useful to you.

Inheritance works exactly the same way. If you have a method with `Vehicle` as a parameter, and if the `Motorcycle` class inherits from the `Vehicle` class, then you can pass an instance of `Motorcycle` to the method. But if the method takes `Motorcycle` as a parameter, you can't pass any `Vehicle` object, because it may be a `Van` instance. Otherwise C# wouldn't know what to do when the method tries to access the `Handlebars` property!

You can always pass an instance of a subclass to any method whose parameters expect a class that it inherits from.

A subclass can access its base class using the base keyword

Even when you override a method or property in your base class, sometimes you'll still want to access it. Luckily, we can use **base**, which lets us access any method in the base class.

- 1 All animals eat, so the `Animal` class has an `Eat()` method that takes a `Food` object as its parameter.

```
public class Animal {
    public virtual void Eat(Food morsel) {
        Swallow(morsel);
        Digest();
    }
}
```

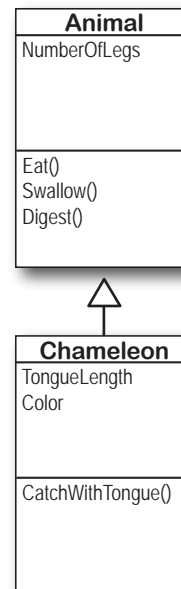

- 2 Chameleons eat by catching food with their tongues. So the `Chameleon` class inherits from `Animal` but overrides `Eat()`.

```
public class Chameleon : Animal {
    public override void Eat(Food morsel) {
        CatchWithTongue(morsel);
        Swallow(morsel);
        Digest();
    }
}
```

The chameleon needs to swallow and digest the food, just like any other animal. Do we really need to duplicate this code, though?

- 3 Instead of duplicating the code, we can use the **base** keyword to call the method that was overridden. Now we have access to both the old and the new version of `Eat()`.

```
public class Chameleon : Animal {
    public override void Eat(Food morsel) {
        CatchWithTongue(morsel);
        base.Eat(morsel);
    }
}
```

This line calls the `Eat()` method in the base class that `Chameleon` inherited from.

When a base class has a constructor, your subclass needs one too

If your class has constructors which take parameters, then any class that inherits from it **must call one of those constructors**. The subclass's constructor can have different parameters from the base class constructor.

```
public class Subclass : BaseClass {
    public Subclass(parameter list)
        : base(the base class's parameter list) {
        // first the base class constructor is executed
        // then any statements here get executed
    }
}
```

Here's the constructor for the subclass.

Add this extra line to the end of your subclass's constructor declaration to tell C# that it needs to call the base class's constructor every time the subclass is instantiated.

The base class constructor is executed before the subclass constructor

But don't take our word for it—see for yourself!

- 1 **Create a base class with a constructor that pops up a messagebox**
Then add a button to a form that instantiates this **base class** and shows a messagebox:

```
public class MyBaseClass {
    public MyBaseClass(string baseClassNeedsThis) {
        MessageBox.Show("This is the base class: " + baseClassNeedsThis);
    }
}
```

This is a parameter that the base class constructor needs.

- 2 **Try adding a subclass, but don't call the constructor**
Then add a button to a form that instantiates this **subclass** and shows a messagebox:

```
public class MySubclass : MyBaseClass{
    public MySubclass(string baseClassNeedsThis, int anotherValue) {
        MessageBox.Show("This is the subclass: " + baseClassNeedsThis
            + " and " + anotherValue);
    }
}
```

Select Build >> Build Solution in the IDE and you'll get an error from this code.

1 No overload for method 'MyBaseClass' takes '0' arguments

Keep an eye out for this slightly cryptic error. It means that your subclass didn't call the base constructor.

- 3 **Fix the error by making the constructor call the one from the base class**
Then instantiate the subclass and **see what order** the two message boxes pop up!

```
public class MySubclass : MyBaseClass{
    public MySubclass(string baseClassNeedsThis, int anotherValue)
        : base(baseClassNeedsThis) {
        // the rest of the subclass is the same
    }
}
```

This is how we send the base class the parameter its constructor needs.

Add this line to tell C# to call the constructor in the base class. It has a parameter list that shows what gets passed to the base class constructor. Then the error will go away and you can make a button to see the two message boxes pop up!

you are here >

Now you're ready to finish the job for Kathleen!

When you last left Kathleen, you'd finished adding birthday parties to her program. She needs you to charge an extra \$100 for parties over 12. It seemed like you were going to have to write the same exact code twice, once for each class. Now that you know how to use inheritance, you can have them inherit from the same base class that contains all of their shared code, so you only have to write it once.

DinnerParty
NumberOfPeople CostOfDecorations CostOfBeveragesPerPerson HealthyOption
CalculateCostOfDecorations() CalculateCost() SetHealthyOption()

BirthdayParty
NumberOfPeople CostOfDecorations CakeSize CakeWriting
CalculateCostOfDecorations() CalculateCost()



If we play our cards right, we should be able to change the two classes without making any changes to the form!

1 Let's create the new class model

We'll still have the same DinnerParty and BirthdayParty classes, but now they'll inherit from a single Party class. We need them to have exactly the same methods, properties and fields, so we don't have to make any changes to the form. But some of those methods, properties, and fields will be moved into the Party base class, and we may have to override a few of them.

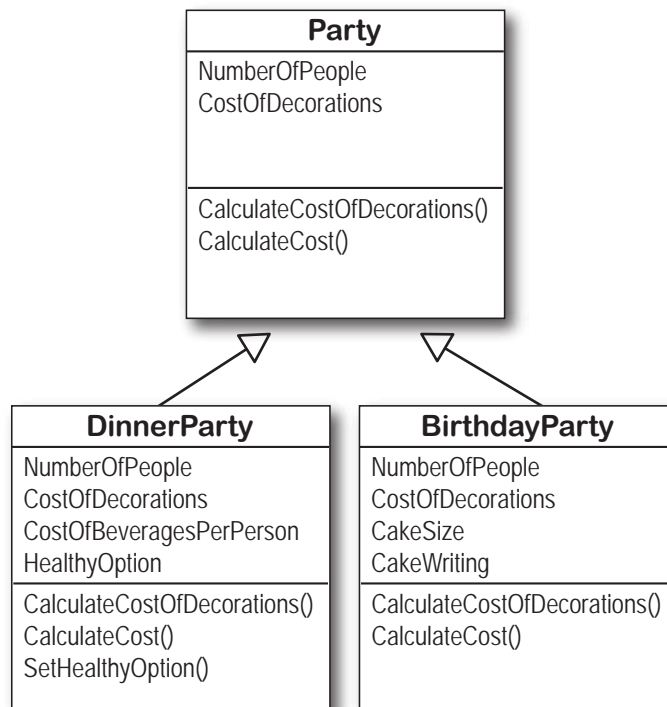

2 Build the Party base class

Create the Party class—make sure it’s public. You’ll need to look really closely at the properties and methods in the class diagram, and figure out what you need to move out of DinnerParty and BirthdayParty and into Party.

- Later on, you’ll learn about the ‘protected’ keyword. A protected field is public to a subclass, but private to everyone else.”
- ★ Move the NumberOfPeople and CostOfDecorations properties into it so that they’re compatible with both DinnerParty and BirthdayParty.
 - ★ Do the same for the CalculateCostOfDecorations() and CalculateCost() methods. If those methods need any private fields, you’ll need to move them too. (Remember, subclasses can only see **public** fields—once you move a private field to Party, the DinnerParty and BirthdayParty classes won’t have access to it.)
 - ★ You’ll also need a constructor. Take a close look at the BirthdayParty and DinnerParty constructors—anything they have in common should be moved to it.
 - ★ Now **add the \$100 bonus** for parties over 12 people. After all, that’s why we’re doing this! It’s common to both birthday and dinner parties, so it belongs in Party.

3 Make DinnerParty inherit from Party

Now that Party does a lot of the things DinnerParty does, you can eliminate the overlap and only keep the part of DinnerParty that’s unique to dinner parties.

- ★ Make sure the constructor is working properly. Does it do anything the Party constructor doesn’t? If so, keep that and then leave everything else to the base class constructor.
- ★ Any logic that has to do with setting the healthy option should stay in DinnerParty.
- ★ Uh-oh—we can’t override the CalculateCost() method here if we want to keep the form code the same, because our form needs to pass it a `bool` called `healthyOption`. So instead, we’ll **overload** it—which just means adding a new CalculateCost() method to the class that takes different parameters. So you’ll use exactly the same declaration for the method that you used at the beginning of the chapter. But you can still take advantage of inheritance by calling `base.CalculateCost()` to access the CalculateCost() method in the Party class.

You’ll learn all about overloading in Chapter 8—this is just a sneak preview to give you a leg up on it later.

4 Make BirthdayParty inherit from Party

Do the same thing for BirthdayParty—leave anything not specific to birthdays to the base class, and only keep the birthday-specific functionality in BirthdayParty.

- ★ What does the BirthdayParty constructor need to do that’s not part of Party?
- ★ You’ll need to deal with the cost of the cake inside of BirthdayParty. That touches a method and a property, so you’ll need to override them.
- ★ Yes, you can override a property! It’s just like overriding a method. When you set the value of `base.NumberOfPeople`, it calls the property’s set accessor in the base class. You’ll need to use the `base` keyword to both get and set the value.



Exercise Solution

Check it out—you changed the DinnerParty and BirthdayParty classes so that they inherited from the same base class, Party. Then you were able to make the change to the cost calculation to add the \$100 fee, and you didn't have to change the form at all. Neat!

```
public class Party
{
    const int CostOfFoodPerPerson = 25;
    private bool fancyDecorations;
    public decimal CostOfDecorations = 0;

    public Party(int numberOfPeople, bool fancyDecorations) {
        this.fancyDecorations = fancyDecorations;
        this.NumberOfPeople = numberOfPeople;
    }

    private int numberOfPeople;
    public virtual int NumberOfPeople {
        get { return numberOfPeople; }
        set {
            numberOfPeople = value;
            CalculateCostOfDecorations(fancyDecorations);
        }
    }

    public void CalculateCostOfDecorations(bool fancy) {
        fancyDecorations = fancy;
        if (fancy)
            CostOfDecorations = (NumberOfPeople * 15.00M) + 50M;
        else
            CostOfDecorations = (NumberOfPeople * 7.50M) + 30M;
    }

    public virtual decimal CalculateCost() {
        decimal TotalCost = CostOfDecorations + (CostOfFoodPerPerson * NumberOfPeople);
        if (NumberOfPeople > 12)
        {
            TotalCost += 100M;
        }
        return TotalCost;
    }
}
```

This code was moved straight out of the DinnerParty and BirthdayParty classes and into Party.

The Party constructor does everything that was previously in both the DinnerParty and BirthdayParty constructors.

NumberOfPeople needs to be virtual because BirthdayParty needs to override it (so that a change to the number of people calculates a new cake size).

The decoration calculation is identical in both birthday and dinner parties, so it makes sense to move it to Party. That way none of the code is duplicated in multiple classes.

The cost calculation needs to be a virtual method because the birthday party overrides it (and also extends it by calling the base class method).

```

public class BirthdayParty : Party {
    public int CakeSize;

    public BirthdayParty(int numberOfPeople, bool fancyDecorations, string cakeWriting)
        : base(numberOfPeople, fancyDecorations) {
        CalculateCakeSize();
        this.CakeWriting = cakeWriting;
        CalculateCostOfDecorations(fancyDecorations);
    }

    private void CalculateCakeSize() {
        if (NumberOfPeople <= 4)
            CakeSize = 8;
        else
            CakeSize = 16;
    }

    private string cakeWriting = "";
    public string CakeWriting {
        get { return this.cakeWriting; }
        set {
            int maxLength;
            if (CakeSize == 8)
                maxLength = 16;
            else
                maxLength = 40;
            if (value.Length > maxLength) {
                MessageBox.Show("Too many letters for a " + CakeSize + " inch cake");
                if (maxLength > this.cakeWriting.Length)
                    maxLength = this.cakeWriting.Length;
                this.cakeWriting = cakeWriting.Substring(0, maxLength);
            } else
                this.cakeWriting = value;
        }
    }

    public override decimal CalculateCost() {
        decimal CakeCost;
        if (CakeSize == 8)
            CakeCost = 40M + CakeWriting.Length * .25M;
        else
            CakeCost = 75M + CakeWriting.Length * .25M;
        return base.CalculateCost() + CakeCost;
    }

    public override int NumberOfPeople {
        get { return base.NumberOfPeople; }
        set {
            base.NumberOfPeople = value;
            CalculateCakeSize();
            this.CakeWriting = cakeWriting;
        }
    }
}

```

The constructor relies on the base class to do most of the work. Then it calls CalculateCakeSize(), just like the old BirthdayParty constructor did.

The CalculateCakeSize() method is specific to birthday parties, so it stays in the BirthdayParty class.

The CakeWriting property stays intact in the BirthdayParty class too.

CalculateCost() also needs to be overridden, because it needs to first calculate the cost of the cake, and then add it to the cost that's calculated in the Party class's CalculateCost() method.

The NumberOfPeople property has to override the one in Party because the set accessor needs to recalculate the cake size. The set accessor needs to call base.NumberOfPeople so that the set accessor in Party also gets executed.

→ Continues on page 238.



Exercise Solution CONTINUED FROM P.237

```

public class DinnerParty : Party
{
    public decimal CostOfBeveragesPerPerson;

    public DinnerParty(int numberOfPeople, bool healthyOption,
        bool fancyDecorations)
        : base(numberOfPeople, fancyDecorations)
        {
            SetHealthyOption(healthyOption);
            CalculateCostOfDecorations(fancyDecorations);
        }

    public void SetHealthyOption(bool healthyOption)
    {
        if (healthyOption)
            CostOfBeveragesPerPerson = 5.00M;
        else
            CostOfBeveragesPerPerson = 20.00M;
    }

    public decimal CalculateCost(bool healthyOption)
    {
        decimal totalCost = base.CalculateCost()
            + (CostOfBeveragesPerPerson * NumberOfPeople);

        if (healthyOption)
            return totalCost * .95M;
        else
            return totalCost;
    }
}

```

Here's the last class in Kathleen's solution. (There's no change to the form code.)

This public field is only used in dinner parties, not birthday parties, so it stays in the class.

To do what the old DinnerParty class did, the new constructor calls the Party constructor and then calls SetHealthyOption().

The SetHealthyOption() method stays exactly the same.

DinnerParty needs a different CalculateCost() that takes a parameter, so instead of overriding it we overloaded it. It calls the CalculateCost() method in Party using the base keyword, and then adds the cost of the beverages and adds in the healthy option discount.

The program's perfect. It's so much easier to run my business now—thanks so much!

You'll learn all about how overloading works in Chapter 8.

Uh-oh—there's still a potential bug still in the program!

Now the DinnerParty class has two CalculateCost() methods, one that it inherits from Party and this new one that we added. We haven't fully encapsulated the class—someone could easily misuse this code by calling the wrong Calculatecost() method. So if you do this:

```

DinnerParty dinner = new DinnerParty(5, true, true);
decimal cost1 = dinner.CalculateCost(true);
decimal cost2 = dinner.CalculateCost();

```

cost1 will be set to 261.25, while cost2 will be set to 250. This isn't an academic question -- it's a real problem. Sometimes there's code in the base class that you don't want to call directly. Even worse, we never intended the Party class to be instantiated... but there's nothing stopping someone from doing it. Do we even know what will happen if someone creates an instance of Party? We can be pretty sure it'll do something we didn't plan for.

Luckily, C# gives us a really good solution to these problems, which you'll learn about in the next chapter!



Build a beehive management system

A queen bee needs your help! Her hive is out of control, and she needs a program to help manage it. She's got a beehive full of workers, and a whole bunch of jobs that need to be done around the hive. But somehow she's lost control of which bee is doing what, and whether or not she's got the beepower to do the jobs that need to be done.

It's up to you to build a beehive management system to help her keep track of her workers. Here's how it'll work:



1 The queen assigns jobs to her workers

There are six possible jobs that the workers can do. Some know how to collect nectar and manufacture honey, others can maintain the hive and patrol for enemies. A few bees can do every job in the hive. So your program will need to give her a way to assign a job to any bee that's available to do it.

The bees work shifts, and most jobs require more than one shift. So the queen enters the number of shifts the job will take, and clicks the "Assign this job" button.

This dropdown list shows all six jobs that the workers can do. The queen knows what jobs need to be done, and she doesn't really care which bee does each job. So she just selects which job has to be done—the program will figure out if there's a worker available to do it and assign the job to him.

If there's a bee available to do the job, the program assigns the job to the bee and lets the queen know it's taken care of.

2 When the jobs are all assigned, it's time to work

Once the queen's done assigning the work, she'll tell the bees to work the next shift by clicking the "Work the next shift" button. The program then generates a shift report that tells her which bees worked that shift, what jobs they did, and how many more shifts they'll be working each job.





First you'll build the basic system

This project is divided into two parts. The first part is a bit of a review, where you'll create the basic system to manage the hive. It's got two classes, Queen and Worker. You'll build the form for the system, and hook it up to the two classes. And you'll make sure the classes are well encapsulated so they're easy to change when you move on to the second part.

Sometimes class diagrams list private fields and types.

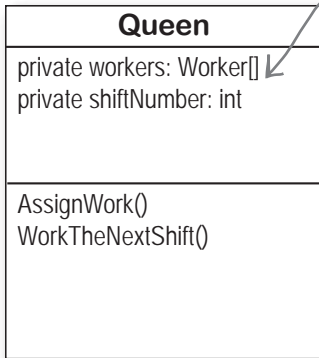

The program has one Queen object that manages the work being done.

- ★ The Queen uses an array of Worker objects to track each of the worker bees and whether or not those bees have been assigned jobs. It's stored in a private Worker[] field called `worker`.
- ★ The form calls the `AssignWork()` method, passing a string for the job that needs to be performed and an int for the number of shifts. It'll return true if it find a worker to assign the job to, or false if it couldn't find a worker to do that job.
- ★ The form's "Work the next shift" button calls `WorkTheNextShift()`, which tells the workers to work and returns a shift report to display. It tells each Worker object to work one shift, and then checks that worker's status so it can add a line to the shift report.

CurrentJob and ShiftsLeft are read-only properties.

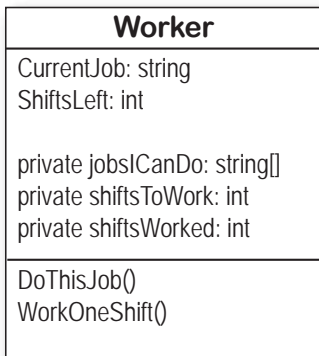

The queen uses an array of Worker objects to keep track of all of the workers and what jobs they're doing.

- ★ `CurrentJob` is a read-only property that tells the Queen object what job the worker's doing ("Sting patrol", "Hive maintenance", etc.) If the worker isn't doing any job, it'll return an empty string.
- ★ The Queen object attempts to assign a job to a worker using its `DoThisJob()` method. If that worker is not already doing the job, and if that's a job that he knows how to do, then he'll accept the assignment and the method returns true. Otherwise, it returns false.
- ★ When the `WorkOneShift()` method is called, the worker works a shift. He keeps track of how many shifts are left in the current job. If the job is done, then he resets his current job to an empty string so that he can take on his next assignment.

String.IsNullOrEmpty()

Each bee stores its current job as a string. So a worker can figure out if he's currently doing a job by checking his `CurrentJob` property – it'll be equal to an empty string if he's waiting for his next job. C# gives you an easy way to do that: `String.IsNullOrEmpty(CurrentJob)` will return true if the `CurrentJob` string is either empty or null, false otherwise.



Exercise

A queen bee needs your help! Use what you've learned about classes and objects to build a beehive management system to help her track her worker bees.

1 Build the form

The form is pretty simple—all of the intelligence is in the Queen and Worker classes. The form has a private Queen field, and two buttons call its AssignWork() and WorkTheNextShift() methods. You'll need to add a ComboBox control for the bee jobs (flip back to the previous page to see its list items), a NumericUpDown control, two buttons, and a multiline textbox for the shift report. You'll also need the form's constructor—it's below the screenshot.

This is a ComboBox control named workerBeeJob. Use its Items property to set the list, and set its DropDownStyle property to "DropDownList" so the user is only allowed to choose items from the list. The Shifts box is a NumericUpDown control called shifts.

Name this text box "report" and set its MultiLine property to true.

The nextShift button calls the queen's WorkTheNextShift() method, which returns a string that contains the shift report.

Look closely at this shift report, which the Queen object generates. It starts with a shift number, and then reports what each worker is doing. Use the escape sequences "\r\n" to add a line break in the middle of a string.

```
public Form1() {
    InitializeComponent();
    Worker[] workers = new Worker[4];
    workers[0] = new Worker(new string[] { "Nectar collector", "Honey manufacturing" });
    workers[1] = new Worker(new string[] { "Egg care", "Baby bee tutoring" });
    workers[2] = new Worker(new string[] { "Hive maintenance", "Sting patrol" });
    workers[3] = new Worker(new string[] { "Nectar collector", "Honey manufacturing",
        "Egg care", "Baby bee tutoring", "Hive maintenance", "Sting patrol" });
    queen = new Queen(workers);
}
```

Each Worker object's constructor takes one parameter, an array of strings that tell it what jobs it knows how to do.

Your form will need a Queen field called queen. You'll pass that array of Worker object references to the Queen object's constructor.

2 Build the Worker and Queen classes

You've got almost everything you need to know about the Worker and Queen classes. There are just a couple more details. Queen.AssignWork() loops through the the Queen object's worker array and attempts to assign the job to each Worker using its DoThisJob() method. The Worker object checks its jobsICanDo string array to see if it can do the job. If it can, it sets its private shiftsToWork field to the job duration, its CurrentJob to the job, and its shiftsWorked to zero. When it works a shift, it increases shiftsWorked by one. The read-only ShiftsLeft property returns shiftsToWork - shiftsWorked—the queen uses it to see how many shifts are left on the job.



Exercise Solution

ShiftsLeft is a read-only property that calculates how many shifts are left on the current job.

CurrentJob is a read-only property that tells the queen which job needs to be done.

The queen uses the worker's DoThisJob() method to assign work to him—he checks his JobsICanDo property to see if he knows how to do the job.

The queen uses the worker's WorkOneShift() method to tell him to work the next shift. The method only returns true if this is the very last shift that he's doing the job. That way the queen can add a line to the report that the bee will be done after this shift.

```

public class Worker {
    public Worker(string[] jobsICanDo) {
        this.jobsICanDo = jobsICanDo;
    }

    public int ShiftsLeft {
        get {
            return shiftsToWork - shiftsWorked;
        }
    }

    private string currentJob = "";
    public string CurrentJob {
        get {
            return currentJob;
        }
    }

    private string[] jobsICanDo;
    private int shiftsToWork;
    private int shiftsWorked;

    public bool DoThisJob(string job, int numberOfShifts) {
        if (!String.IsNullOrEmpty(currentJob))
            return false;
        for (int i = 0; i < jobsICanDo.Length; i++)
            if (jobsICanDo[i] == job) {
                currentJob = job;
                this.shiftsToWork = numberOfShifts;
                shiftsWorked = 0;
                return true;
            }
        return false;
    }

    public bool WorkOneShift() {
        if (String.IsNullOrEmpty(currentJob))
            return false;
        shiftsWorked++;
        if (shiftsWorked > shiftsToWork) {
            shiftsWorked = 0;
            shiftsToWork = 0;
            currentJob = "";
            return true;
        }
        else
            return false;
    }
}
    
```

The constructor just sets the JobsICanDo property, which is a string array. It's private because we want the queen to ask the worker to do a job, rather than make her check whether he knows how to do it.

We used !—the NOT operator—to check if the string is NOT null or empty. It's just like checking to see if something's false.

Take a close look at the logic here. First it checks the currentJob field: if the worker's not working on a job, it just returns false, which stops the method. If not, then it increments ShiftsWorked, and then checks to see if this is the job's done by comparing it with ShiftsToWork. If it is, the method returns true. Otherwise it returns false.

```

public class Queen {
    public Queen(Worker[] workers) {
        this.workers = workers;
    }

    private Worker[] workers;
    private int shiftNumber = 0;

    public bool AssignWork(string job, int numberOfShifts) {
        for (int i = 0; i < workers.Length; i++)
            if (workers[i].DoThisJob(job, numberOfShifts))
                return true;
        return false;
    }

    public string WorkTheNextShift() {
        shiftNumber++;
        string report = "Report for shift #" + shiftNumber + "\r\n";
        for (int i = 0; i < workers.Length; i++)
        {
            if (workers[i].WorkOneShift())
                report += "Worker #" + (i + 1) + " finished the job\r\n";
            if (String.IsNullOrEmpty(workers[i].CurrentJob))
                report += "Worker #" + (i + 1) + " is not working\r\n";
            else
                if (workers[i].ShiftsLeft > 0)
                    report += "Worker #" + (i + 1) + " is doing '" + workers[i].CurrentJob
                        + "' for " + workers[i].ShiftsLeft + " more shifts\r\n";
                else
                    report += "Worker #" + (i + 1) + " will be done with '"
                        + workers[i].CurrentJob + "' after this shift\r\n";
        }
        return report;
    }
}

```

The queen keeps her array of workers private because once they're assigned, no other class should be able to change them... or even see them, since she's the only one who gives them orders. The constructor sets the field's value.

When she assigns work to her worker bees, she starts with the first one and tries assigning him the job. If he can't do it, she moves on to the next. When a bee who can do the job is found, the method returns (which stops the loop).

The queen's `WorkTheNextShift()` method tells each worker to work a shift and adds a line to the report depending on the worker's status.

We already gave you the constructor. Here's the rest of the code for the form:

```

Queen queen;

private void assignJob_Click(object sender, EventArgs e) {
    if (queen.AssignWork(workerBeeJob.Text, (int)shifts.Value) == false)
        MessageBox.Show("No workers are available to do the job '"
            + workerBeeJob.Text + "'", "The queen bee says...");
    else
        MessageBox.Show("The job '" + workerBeeJob.Text + "' will be done in "
            + shifts.Value + " shifts", "The queen bee says...");
}

private void nextShift_Click(object sender, EventArgs e) {
    report.Text = queen.WorkTheNextShift();
}

```

The form uses its queen field to keep a reference to the Queen object, which in turn has an array of references to the worker objects.

The `assignJob` button calls the queen's `AssignWork()` method to assign work to a worker, and displays a message box depending on whether or not a worker's available to do the job.

The `nextShift` button tells the queen to work the next shift. She generates a report, which it displays in the report text box.



Objectcross

Before you move on to the next part of the exercise, give your brain a break with a quick crossword.

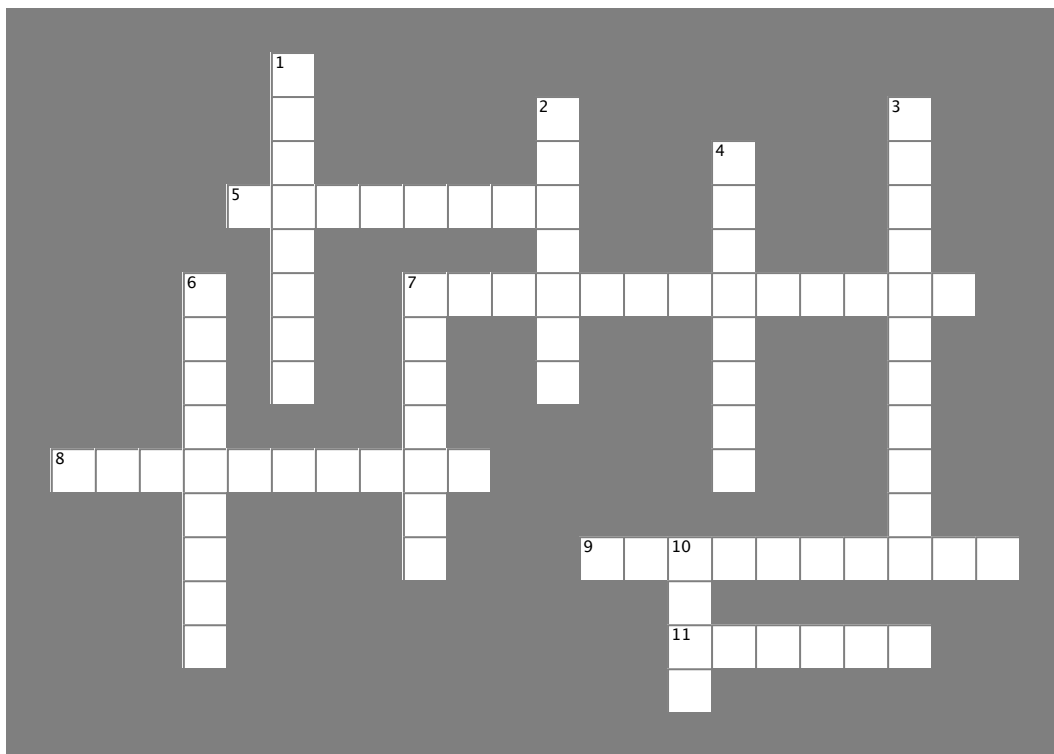

Across

- 5. This method gets the value of a property.
- 7. This method returns true if you pass it "".
- 8. The constructor in a subclass class doesn't need the same _____ as the constructor in its base class.
- 9. A control on a form that lets you create tabbed applications.
- 11. This type of class can't be instantiated.

Down

- 1. A _____ can override methods from its base class.
- 2. If you want a subclass to override a method, mark the method with this keyword in the base class.
- 3. A method in a class that's run as soon as it's instantiated.
- 4. What a subclass does to replace a method in the base class.
- 6. This contains base classes and subclasses
- 7. What you're doing when add a colon to a class declaration.
- 10. A subclass uses this keyword to call the members of the class it inherited from.

—————> **Answers on page 250.**



Use inheritance to extend the bee management system

Now that you have the basic system in place, use inheritance to let it track how much honey each bee consumes. Different bees consume different amounts of honey, and the queen consumes the most honey of all. So you'll use what you've learned about inheritance to create a Bee base class that Queen and Worker inherit from.

The Bee class has the basic honey consumption behavior. Since honey consumption requires the number of shifts left, we'll move the ShiftsLeft property into it and mark it virtual so the Worker can override it.

All bees consume honey, so we'll add a GetHoneyConsumption() method to the base class so the queen and workers can inherit it. But bees and workers consume honey differently. We'll make it a virtual method, so one of the subclasses can override it.

The queen needs to change her report to add honey consumption data. That means she needs to add each worker's honey consumption—and since she consumes honey herself, she'll need to inherit from Bee and override its virtual GetHoneyConsumption() method.

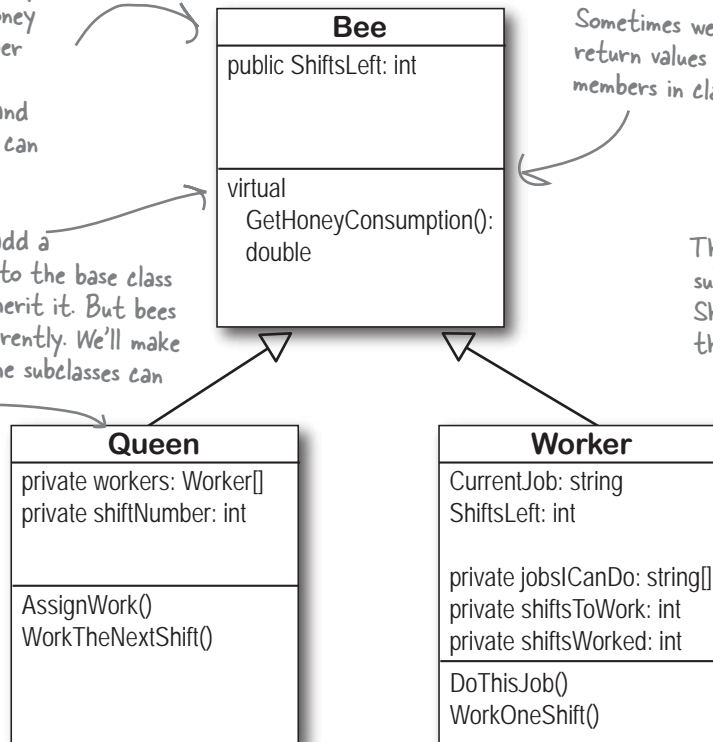

Sometimes we'll show you return values and private members in class diagrams.

The worker just needs to subclass Bee override the ShiftsLeft method with the one you already wrote.

Add Existing Item

Whenever you have a two-part exercises, it's always a good idea to start a new project for the second part. That way you can always get back to the first solution if you need it. An easy way to do that is to right-click on the project name in the new project's Solution Explorer in the IDE, select 'Add Existing Item' from the menu, navigate to the old project's folder, and select the files you want to add. The IDE will make new copies of those files in the new project's folder, and add them to the project. There are a few things to watch out for, though. The IDE will NOT change the namespace, so you'll need to edit each class file and change its namespace line by hand. And if you add a form, make sure to add its designer (.Designer.cs) and resource (.resx) files—and make sure you change their namespaces, too.





Exercise

We're not done yet! The queen needs to keep track of how much honey the hive is spending on its workers. Here's a perfect chance to use your new inheritance skills!

1 The queen needs to know how much honey the hive uses

The queen just got a call from her accountant bees, who told her that the hive isn't producing enough honey. She'll need to know how much honey she and her workers are using so she can decide whether to divert workers from egg maintenance to honey production.

- ★ All bees eat honey, so the hive runs through a lot of honey. That's why they need to keep making more of it.
- ★ Worker bees use more honey when they're working. They need the most honey when the job starts, to give them plenty of energy for the job. They consume less and less as the job goes on. On the last shift the bee uses 10 units of honey, the second-to-last shift he uses 11 units, the shift before that he uses 12 units, etc. So if the bee's working (meaning its `ShiftsLeft` is greater than zero), then you can find out how many units of honey to consume by adding 9 to `ShiftsLeft`.
- ★ If a bee doesn't have a job (i.e., its `ShiftsLeft` is zero), he only uses 7.5 units of honey for the shift.
- ★ Those numbers are all for normal bees. If a bee weighs over 150 milligrams, it uses 35% more honey. This doesn't include queens, though (see below).
- ★ Queens require a lot of honey. A queen uses more honey when she's got more workers doing jobs, because it's a lot of work overseeing them. She needs to consume as much honey as if she'd worked as many shifts as the worker with the most shifts left on his job.
- ★ Then she needs even more honey: she uses 20 extra units of honey per shift if there are 2 or fewer workers working, or 30 extra units of honey if there are 3 or more worker bees doing jobs. The queen's consumption isn't subject to the 35% rule, since all queens weigh 275 milligrams.
- ★ The queen needs all the honey consumption numbers added to the end of each shift report.

2 Create a Bee class to handle the honey calculations

Since the workers and queen all do their honey calculations in similar ways, you'll be able to avoid duplicating your code by having a `Bee` base class that `Worker` and `Queen` can inherit from. You know that each bee needs to know its weight (so it knows whether to multiply its honey expenditure by 35%).

- ★ Create a `GetHoneyConsumption()` method that calculates the amount of honey that a worker uses. Since the workers and queen all need to do this calculation but the queen needs to do extra calculations as well, it makes sense for the worker to inherit it and the queen to override it.
- ★ The `GetHoneyConsumption()` method needs the number of shifts left, so add a virtual read-only property called `ShiftsLeft` that returns zero. The worker's `ShiftsLeft` will override it.
- ★ The honey consumption calculation needs to know the bee's weight, so the `Bee` constructor will need to take the weight as a parameter and store it in a field. Since no other class needs to use it, you should make it private.



Here's a good rule of thumb. You should make fields and methods private by default, and only make them public if another class needs them. That way you avoid bugs in your programs caused by one class accessing another class's properties or methods incorrectly.



Hint: You can use the slightly cryptic “no overload” error message to your advantage! Have the Worker class inherit from Bee, then build your project. When the IDE displays the error, double-click on it and the IDE will jump right to the Worker constructor automatically. How convenient!

3 Make the Worker class inherit from Bee

You’ll need to set up the constructor to call the base class constructor, like you did with Kathleen. You’ll need to change the Worker constructor so that it takes the bee’s weight as a parameter, and pass that parameter on to the base class constructor. Then, just add the `override` keyword to the Worker’s `ShiftLeft` method. Once you do that, each worker will be able to calculate his honey consumption for the queen... and you don’t have to make any more changes to the Worker class!

4 Make the Queen class inherit from Bee

The Queen class needs a little more alteration than the Worker class, since she needs to actually do the honey calculation and add it to the shift report.

- ★ Override the `Bee.GetHoneyConsumption()` method and add the queen’s extra calculation. She’ll need to figure out whether she has 2 or fewer workers with jobs, so she knows whether she needs 20 or 30 units. Then she’ll need to add that to the number of units she’d use if she had the same number of shifts left as the worker with the most shifts left.
- ★ Update the queen’s `WorkTheNextShift()` by adding the a honey consumption line to the report. Add a loop to add up the honey consumptions for each worker and also find the worker with the largest honey consumption—do it **before** the queen tells each worker to work each shift (so she gets the consumption numbers for the current shift). She’ll add those up, add her own consumption, and then add a line to the end of the shift report that says, “Total Honey Consumption: xxx units” (where xxx is the number of units of honey consumed).
- ★ You’ll need to update the Queen constructor just like you did for Worker.

Go to the Queen class and type “public override”—when you press the space bar, the IDE automatically lists all the methods you can override. Select the method you want to override and it’ll fill in the base method call automatically.

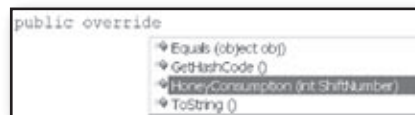

5 Update the form to instantiate the bees properly

Since you changed the Queen and Worker constructors, you’ll also need to change the way they’re called. Each constructor has a new `Weight` parameter, so you’ll need weights to use:

- ★ Worker Bee #1: 175mg; Worker Bee #2: 114mg; Worker Bee #3: 149mg;
Worker Bee#4: 155mg; Queen Bee: 275mg

That’s the only change you’ll need to make to the form!



Exercise Solution

Here's the Bee class. It does the basic honey consumption calculation that's used by both the Worker and Queen classes.

```
public class Bee {
    public Bee(double weight) {
        this.weight = weight;
    }

    public virtual int ShiftsLeft {
        get { return 0; }
    }

    private double weight;

    public virtual double GetHoneyConsumption() {
        double consumption;
        if (ShiftsLeft == 0)
            consumption = 7.5;
        else
            consumption = 9 + ShiftsLeft;
        if (weight > 150)
            consumption *= 1.35;
        return consumption;
    }
}
```

The Bee class has a constructor that sets its Weight field and a HoneyConsumption() method that calculates how much honey a worker consumes.

If a bee has 1 shift left, he consumes 10; if 2 left, he consumes 11, etc. If he has no job, then he consumes 7.5. If ShiftsLeft is zero, then the bee has no job.

If the bee weighs more than 150mg, then consumption goes up by 35%.

Inheritance made it easy for you to update your code and add the new honey consumption behavior to the Queen and Worker classes. It would have been a lot harder to make this change if you'd had a lot of duplicated code.

```
public Form1() {
    InitializeComponent();

    Worker[] workers = new Worker[4];
    workers[0] = new Worker(new string[] { "Nectar collector", "Honey manufacturing" }, 175);
    workers[1] = new Worker(new string[] { "Egg care", "Baby bee tutoring" }, 114);
    workers[2] = new Worker(new string[] { "Hive maintenance", "Sting patrol" }, 149);
    workers[3] = new Worker(new string[] { "Nectar collector", "Honey manufacturing",
        "Egg care", "Baby bee tutoring", "Hive maintenance", "Sting patrol" }, 155);
    queen = new Queen(workers);
}
```

Only the form constructor changed—the rest of the form is exactly the same.

The only change to the form is that the weights need to be added to the Worker constructors.

```
public class Worker : Bee {
    public Worker(string[] jobsICanDo, int weight)
        : base(weight) {
        this.jobsICanDo = jobsICanDo;
    }
    public override int ShiftsLeft {
        // ... the rest of the class is the same ...
    }
}
```

All the Worker class needed was to inherit from Bee and have its constructor adjusted so that it takes a Weight parameter and passes it on to the base class constructor, and overrides the Bee.ShiftsLeft property by adding the override keyword to the property declaration.

The Queen class needed a few changes, starting with inheriting from Bee.

```
public class Queen : Bee {
    public Queen(Worker[] workers)
        : base(275) {
        this.workers = workers;
    }
}
```

The queen weighs 275mg, so her constructor calls the base Bee constructor and passes it a weight of 275.

```
public string WorkTheNextShift()
{
    double totalConsumption = 0;
    for (int i = 0; i < workers.Length; i++)
        totalConsumption += workers[i].GetHoneyConsumption();
    totalConsumption += GetHoneyConsumption();
}
```

The WorkTheNextShift() has a loop added to the top that calls each worker's GetHoneyConsumption() method, and then calls her own GetHoneyConsumption() method to come up with a total consumption.

// ... here's where the original code for this method goes

```
report += "Total honey consumption: " + totalConsumption + " units";
return report;
}
```

The rest of WorkTheNextShift() is the same, except that it adds the honey line to the report.

```
public override double GetHoneyConsumption() {
```

```
    double consumption = 0;
    double largestWorkerConsumption = 0;
    int workersDoingJobs = 0;
    for (int i = 0; i < workers.Length; i++) {
        if (workers[i].GetHoneyConsumption() > largestWorkerConsumption)
            largestWorkerConsumption = workers[i].GetHoneyConsumption();
        if (workers[i].ShiftsLeft > 0)
            workersDoingJobs++;
    }
```

The queen overrides the Bee's GetHoneyConsumption() method to do her honey calculation. It finds the worker with the largest consumption and adds either 20 or 30 to it based on how many workers are working.

This loop looks at the consumption of all the workers and finds the one with the largest consumption.

```
    consumption += largestWorkerConsumption;
    if (workersDoingJobs >= 3)
        consumption += 30;
    else
        consumption += 20;
    return consumption;
}
```

If there are 3 or more workers doing jobs, the queen needs 30 more units of honey; otherwise, she needs 20 more units.



Objectcross Solution

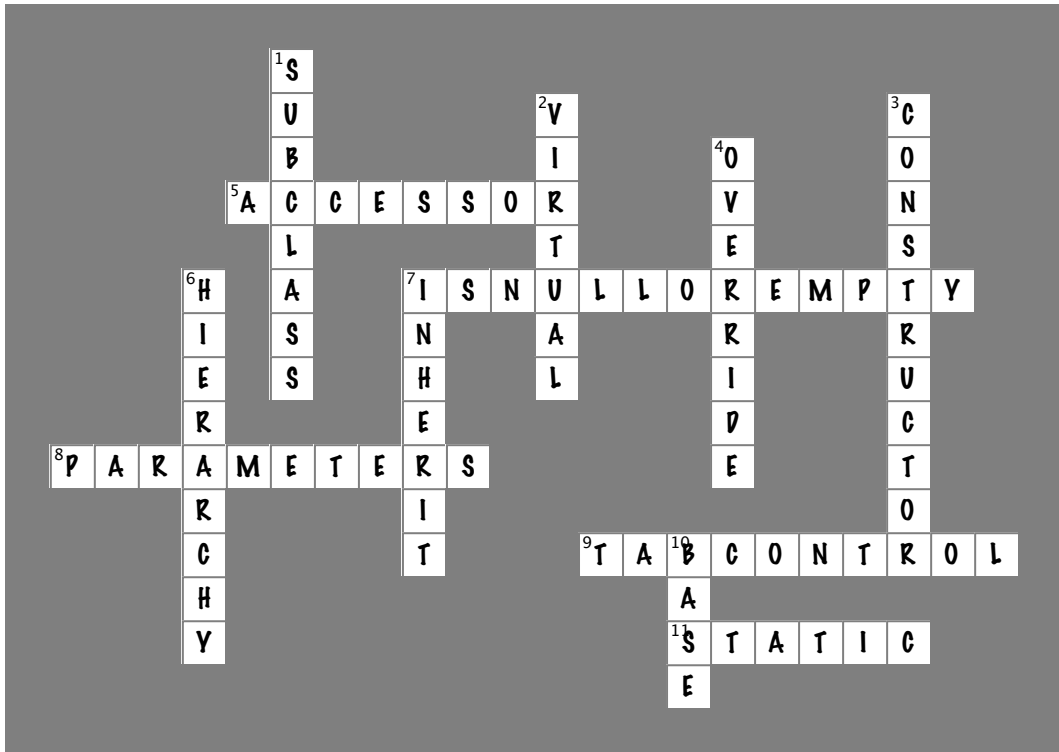

7 interfaces and abstract classes

Making classes keep their promises

Okay, okay, I know I implemented the BookieCustomer interface, but I can't code the PayMoney() method until next weekend.



You've got three days before I send some Thug objects by to make sure you implement the WalksWithALimp() method.

Actions speak louder than words.

Sometimes you need to group your objects together based on the **things they can do** rather than the classes they inherit from. That's where **interfaces** come in—they let you work with any class that can do the job. But with **great power comes great responsibility**, and any class that implements an interface must promise to **fulfill all of its obligations...** or the compiler will break their kneecaps, see?

Let's get back to bee-sics

The General Bee-namics corporation wants to make the Beehive Management System you created in the last chapter into a full-blown Hive Simulator. Here's an overview of the specification for the new version of the program:



General Bee-namics Hive Simulator

To better represent life in the hive, we'll need to add specialized capabilities to the worker bees.

- All bees consume honey and have a weight.
- Queens assign work, monitor shift reports, and tell workers to work the next shift.
- All worker bees work shifts.
- Sting patrol bees will need to be able to sharpen their stingers, look for enemies, and sting them.
- Nectar collector bees are responsible for finding flowers, gathering nectar and then returning to the hive.

The Bee and Worker classes don't look like they'll change much. We can extend the classes we already have to handle these new features.

Looks like we'll need to be able to store different data for the worker bees depending on the job they do.

Lots of things are still the same

The bees in the new hive simulator will still consume honey in the same way they did before. The queen still needs to be able to assign work to the workers and see the shift reports that tell who's doing what. The workers work shifts just like they did before, too, it's just that the jobs they are doing have been elaborated a little bit.

We can use inheritance to create classes for different types of bees

Here's a class hierarchy with Worker and Queen classes that inherit from Bee, and Worker has subclasses NectarCollector and StingPatrol.

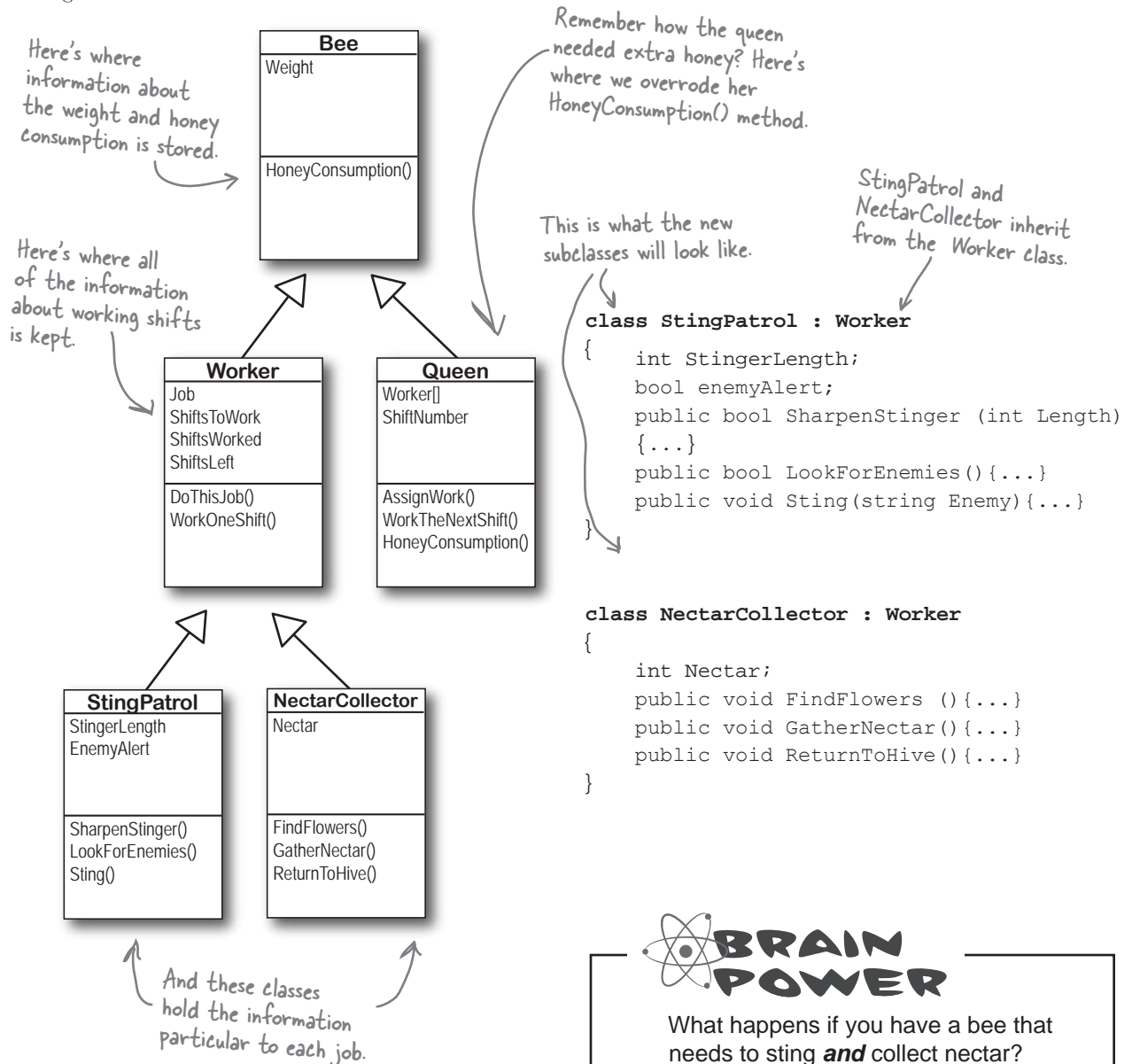

What happens if you have a bee that needs to sting **and** collect nectar?

An interface tells a class that it must implement certain methods and properties

A class can only inherit from one other class. So creating two separate subclasses for the `StingPatrol` and `NectarCollector` bees won't help us if we have a bee that can do **both** jobs.

The queen's `DefendTheHive()` method can only tell `StingPatrol` objects to keep the hive safe. She'd love to train the other bees to use their stingers, but she doesn't have any way to command them to attack:

```
public class Queen {
    private void DefendTheHive(StingPatrol patroller) { ... }
}
```

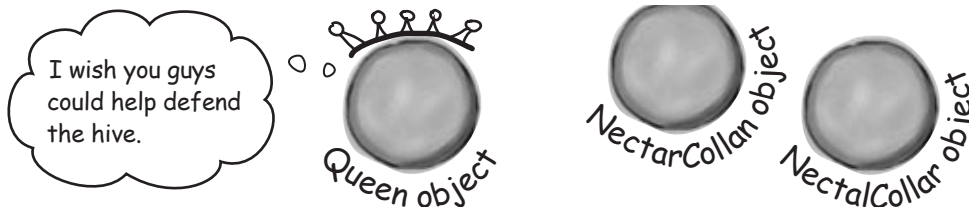

There are `NectarCollector` objects that know how to collect nectar from flowers, and instances of `StingPatrol` that can sharpen their stingers and patrol for enemies. But even if the queen could teach the `NectarCollector` to defend the hive by adding methods like `SharpenStinger()` and `LookForEnemies()` to its class definition, she still couldn't pass it into her `DefendTheHive()` method. Maybe she could use two different methods:

```
private void DefendTheHive(StingPatrol patroller);
private void AlternateDefendTheHive(NectarCollector patroller);
```

But that's not a particularly good solution. Both of those methods would be identical, because they'd call the same methods in the objects passed to them. The only difference is that one method would take a `StingPatrol`, and the other would take a `NectarCollector` that happens to have the methods necessary for patrolling the hive. And you already know how painful it is to maintain two identical methods.

Luckily, C# gives us **interfaces** to handle situations like that. Interfaces let you define a bunch of methods that a class **must** have.

An interface **requires** that a class has certain methods, and the way that it does that is that it **makes the compiler throw errors** if it doesn't find all the methods required by the interface in every class that implements it. Those methods can be coded directly in the class, or they can be inherited from a base class. The interface doesn't care how the methods or properties get there, as long as they're there when the code is compiled.

You use an interface to require a class to include all of the methods and properties listed inside the interface—if it doesn't, the compiler will throw an error.

Even if the queen adds sting patrol methods to a `NectarCollector` object, she still can't pass it to her `DefendTheHive()` method because it expects a `StingPatrol` reference. She can't just set a `StingPatrol` reference equal to a `NectarCollector` object.

She could add a second method called `AlternateDefendTheHive()` that takes a `NectarCollector` reference instead, but that would be cumbersome and difficult to work with.

Plus, the `DefendTheHive()` and `AlternateDefendTheHive()` methods would be identical except for the type of the parameter. If she wanted to teach the `BabyBeeCare` or `Maintenance` objects to defend the hive, she'd need to keep adding new methods. What a mess!

Use the interface keyword to define an interface

Adding an interface to your program is a lot like adding a class, except you never write any methods. You just define the methods' return type and parameters, but instead of a block of statements inside curly brackets you just end the line with a semicolon.

Interfaces do not store data, so you **can't add any fields**. But you *can* add definitions for properties. The reason is that get and set accessors are just methods, and interfaces are all about forcing classes to have certain methods with specific names, types and parameters. So if you've got a problem that looks like it might be solved by adding a field to an interface, try **using a property instead** – the odds are that it'll do what you're looking for.

Interface names start with I

Whenever you create an interface, you should make its name start with an uppercase I. There's no rule that says you need to do it, but it makes your code a lot easier to understand. You can see for yourself just how much easier that can make your life. Just go into the IDE to any blank line inside any method and type "I"—IntelliSense shows .NET interfaces.

```
public interface IStingPatrol
{
    int AlertLevel { get; }
    int StingerLength { get; set; }
    bool LookForEnemies();
    int SharpenStinger(int Length);
}
```

You declare an interface like this:
Interfaces don't store data. So they don't have fields... but they can have properties.

Any class that implements this method must have all of these methods and properties, or the program won't compile.

Any class that implements this interface will need a SharpenStinger() method that takes an int parameter.

```
public interface INectarCollector
{
    void FindFlowers();
    void GatherNectar();
    void ReturnToHive();
}
```

Everything inside an interface is meant to be actually used inside another class. So all of the methods in an interface are automatically public.

You don't write the code for the methods in the interface, just their names. You write the code in the class that implements it.

Everything in a public interface is automatically public, because you'll use it to define the public methods and properties of any class that implements it.

So how does this help the queen? Now she can make one single method that takes any object that knows how to defend the hive:

```
private void DefendTheHive(IStingPatrol patroller)
```

This gives the queen a single method that can take a StingPatrol, NectarStinger, and any other bee that knows how to defend the hive—it doesn't matter which class she passes to the method. As long as it implements IStingPatrol, the DefendTheHive() is guaranteed that the object has the methods and properties it needs to defend the hive.



Now that I know you can defend the hive, we'll all be a lot safer!

Now you can create an instance of NectarStinger that does both jobs

You use the **colon operator** to declare an interface, just like you do for inheritance. It works like this: the first thing after the colon is the class it inherits from, followed by a list of interfaces -- unless it doesn't inherit from a class, in which case it's just a list of interfaces (in no particular order).

You **implement** an interface with a colon operator, just like you inherit.

This class **inherits** from Worker and implements INectarCollector and IStingPatrol.

```
class NectarStinger : Worker, INectarCollector,
IStingPatrol {
    public int AlertLevel {
        get { return alertLevel; }
    }

    public int StingerLength {
        get { return stingerLength; }
        set {
            stingerLength = value;
        }
    }

    public bool LookForEnemies() {...}
    public int SharpenStinger(int Length)
    {...}
    public void FindFlowers() {...}
    public void GatherNectar() {...}
    public void ReturnToHive() {...}
}
```

The NectarStinger sets the backing field for the AlertLevel property in its LookForEnemies() method.

Every method in the interface has a method in the class. Otherwise it wouldn't compile.

You can use more than one interface if you separate them with commas.

When you create a NectarStinger object, it will be able to do the the job of both a NectarCollector and a StingPatrol worker bee.

The bee retracts its stinger when there are no enemies around, so the backing field changes its value over time.

When you've got a class that implements an interface, it acts just like any other class. You can instantiate it with new and use its methods:

```
NectarStinger bobTheBee = new NectarStinger();
bobTheBee.LookForEnemies();
bobTheBee.FindFlowers();
```

there are no Dumb Questions

Q: I still don't quite get how interfaces improve the beehive code. You'll still need to add a NectarStinger class, and it'll still have duplicate code...right?

A: Interfaces aren't about preventing you from duplicating code. They're about letting you use one class in more than one situation. The goal is to create one worker bee class that can do two different jobs. You'll still need to create classes for them—that's not the point. The point of the interfaces is that now you've got a way to have a class that does any number of jobs. Let's say you have a PatrolTheHive() method that takes a StingPatrol object and a CollectNectar() method that takes a NectarCollector object. But you don't want StingPatrol to inherit from NectarCollector or vice versa—each class has public methods and properties that the other one shouldn't have. Now take a minute and try to think of a way to create one single class whose instances could be passed to both methods. Seriously, put the book down, take a minute and try to think up a way! How do you do it?

Interfaces fix that problem. Now you can create an IStingPatrol reference—and that reference can point to any object that implements IStingPatrol, no matter what the actual class is. It can point to a StingPatrol, or a NectarStinger, or even a totally unrelated object. If you've got an IStingPatrol reference pointing to an object, then you know you can use all of the methods and properties that are part of the IStingPatrol interface, regardless of the actual type of the object.

But the interface is only part of the solution. You'll still need to create a new class that implements the interface, because it doesn't actually come with any code. Interfaces aren't about avoiding the creation of extra classes or avoiding duplicate code. They're about making one class that can do more than one job without relying on inheritance, because inheritance brings along a lot of extra baggage—you'll have to inherit every method, property and field, not just the ones that have to do with the specific job.

Can you think of ways that you could still avoid duplicating code while using an interface? You could create a separate class called Stinger or Proboscis to contain the code that's specific to stinging or collecting nectar. NectarStinger and NectarCollector could both create a private instance of Proboscis, and any time they need to collect nectar, they'd call its methods and set its properties.

Classes that implement interfaces have to include ALL of the interface's methods

Implementing an interface means that you have to have a method in the class for each and every property and method that's declared in the interface—if it doesn't have every one of them, it won't compile. If a class implements more than one interface, then it needs to include all of the properties and methods in each of the interfaces it implements. But don't take our word for it...

Do this!

- 1 **Create a new application and add a new class file called `IStingPatrol.cs`**
Instead of adding a class, type in the `IStingPatrol` interface on the previous page.

- 2 **Add a `Bee` class to the project**
Don't add any properties or methods yet. Just have it implement `IStingPatrol`:

```
public class Bee : IStingPatrol {
```

- 3 **Try to compile the program**
Select "Rebuild" from the Build menu. Uh-oh—the compiler won't let you do it:

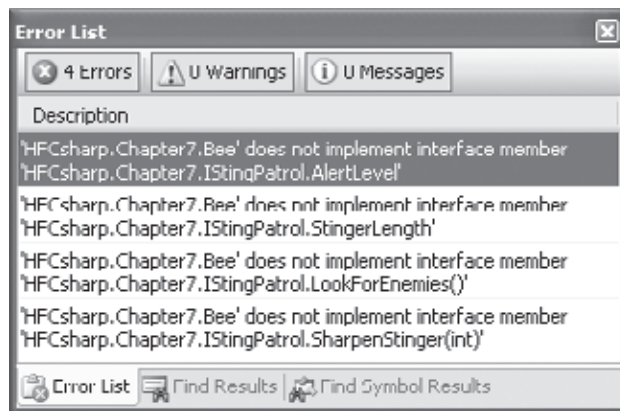

You'll see one of these "does not implement" errors for every member of `IStingPatrol` that's not implemented in the class. The compiler really wants you to implement every method in the interface.

- 4 **Add the methods and properties to the `Bee` class**
Add a `LookForEnemies` method and a `SharpenStinger` method—they don't have to do anything, they just need to compile. Then add a get accessor for an `int` called `AlertLevel` and get and set accessors for an `int` called `StingerLength`. Now the program will compile!

Get a little practice using interfaces

Interfaces are really easy to use, but the best way to understand is to start using them. So create a new Windows Forms Application project, drag a button onto the form, and get started!



- Here's the TallGuy class, and the code for a button that creates it using an object initializer and calls its TalkAboutYourself() method. Nothing new here—we'll use it in a minute:

```
public class TallGuy {
    public string Name;
    public int Height;

    public void TalkAboutYourself() {
        MessageBox.Show("My name is " + Name + " and I'm "
            + Height + " inches tall.");
    }
}

private void button1_Click(object sender, EventArgs e) {
    TallGuy tallGuy = new TallGuy() { Height = 74, Name = "Jimmy" };
    tallGuy.TalkAboutYourself();
}
```

- Let's create an IClown interface for the class.

You already know that everything inside an interface has to be public. But don't take our word for it. Create a new project and declare an interface on your own, like this:

```
public interface IClown
```

Now try to declare a private method inside the interface:

```
private void Honk();
```

Select Build>>Build Solution in the IDE. You'll see this error:

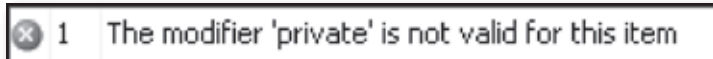

You don't need to type "public" inside the interface, because it automatically makes every property and method public.

Now go ahead and **delete the private access modifier**—the error will go away and your program will compile just fine.

- Before you go on to the next page, see if you can create the rest of the IClown interface, and modify the TallGuy class to implement this interface. Add your interface to your project just like you add a class: right-click on the project in the Solution Explorer and add a class file called IClown.cs.

Your new IClown interface should have a void method called Honk that doesn't take any parameters, and a string read-only property called FunnyThingIHave that has a get accessor but no set accessor.

4 Here's the interface—did you get it right?

```
public interface IClown
{
    string FunnyThingIHave { get; }
    void Honk();
}
```

Here's an example of an interface that has a get accessor without a set accessor. Remember, interfaces can't contain fields, but when you implement this read-only property in a class, it'll look like a field to other objects.

Okay, now modify the TallGuy class so that it implements clown. Remember, the colon operator is always followed by the base class to inherit from (if any), and then a list of interfaces to implement, all separated by commas. Since there's no base class and only one interface to implement, the declaration looks like this:

```
public class TallGuy : IClown
```

TallGuy will implement the IClown interface.

Then make sure the rest of the class is the same, including the two fields and the method. Select "Build Solution" from the Build menu in the IDE to compile and build the program. You'll see two errors, including this one:

What the IDE is telling you is that when you said TallGuy would implement IClown, you promised to add all of the properties and methods in that interface... and then you broke that promise!

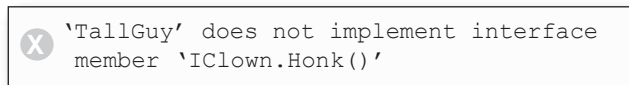

6 The errors will go away as soon as you add all of the methods and properties defined in the interface. So go ahead and implement the interface. Add a read-only string property called FunnyThingIHave with a get accessor that always returns the string "big shoes". Then add a Honk() method that pops up a message box that says, "Honk honk!".

Here's what it'll look like:

```
public string FunnyThingIHave {
    get { return "big shoes"; }
}

public void Honk() {
    MessageBox.Show("Honk honk!");
}
```

All the interface requires is that a class that implements it has a property called FunnyThingIHave with a get accessor. You can put any get accessor in there, even one that just returns the same string every time. Most get accessors won't do this, but this will work just fine if it does what you need it to do.

The interface says that you need a public void method called Honk, but it doesn't say what that method needs to do. It can do anything at all—no matter what it does, the code will compile as long as some method is there with the right signature.

7 Now your code will compile! Update your button so that it calls the TallGuy object's Honk() method.

You can't instantiate an interface, but you can reference an interface

Say you had a method that needed an object that could perform the `FindFlowers()` method. Any object that implemented the `INectarCollector` interface would do. It could be a `Worker` object, or a `Robot` object or a `Dog` object as long as it implements the `INectarCollector` interface.

That's where **interface references** come in. You can use one to refer to an object that implements the interface you need and you'll always be sure that it has the right methods for your purpose—even if you don't know much else about it.

This won't work...

```
ISTingPatrol dennis = new IStingPatrol();
```

✘ 1 Cannot create an instance of the abstract class or interface

You can't use the `new` keyword with an interface, which makes sense—the methods and properties don't have any implementation. If you could create an object from an interface, how would it know how to behave?

...but this will.

```
NectarStinger fred = new NectarStinger();  
ISTingPatrol george = fred;
```

Remember how you could pass a BLT reference into any class that expects a Sandwich, because BLT inherits from Sandwich? Well, this is the same thing—you can use a `NectarStinger` in any method or statement that expects an `ISTingPatrol`.

The first line is an ordinary `new` statement, creating reference called `Fred` and pointing it to a `NectarStinger` object.

The second line is where things start to get interesting, because that line of code **creates a new reference variable using `ISTingPatrol`**. That line may look a little odd when you first see it. But look at this:

```
NectarStinger ginger = fred;
```

You know what this third statement does—it creates a new `NectarStinger` reference called `ginger` and points it at whatever object `fred` is pointing to. The `george` statement uses `ISTingPatrol` the same way.

So what happened?

There's only one `new` statement, so **only one object** was created. The second statement created a reference variable called `george` that can point to an instance of **any class that implements `ISTingPatrol`**.

You can create an array of `IWorker` references, but you can't instantiate an interface. But what you can do is point those references at new instances of classes that implement `IWorker`. Now you can have an array that holds many different kinds of objects!

If you try to instantiate an interface, the compiler will complain.

Even though this object can do more, when you use an interface reference you only have access to the methods in the interface.



Interface references work just like object references

You already know all about how objects live on the heap. When you work with an interface reference, it's just another way to refer to the same objects you've already been dealing with. Look—it's easy!

1 Create a couple of bees

This is totally familiar stuff by now.

```
StingPatrol biff = new StingPatrol();
NectarCollector berthas = new NectarCollector();
```

Let's assume that *StingPatrol* implements the *IStingPatrol* interface and *NectarCollector* implements the *INectarCollector* interface.

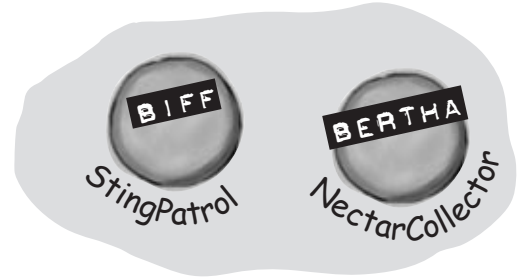

2 Add IStingPatrol and INectarCollector references

You can use interface references just like you use any other reference type.

```
IStingPatrol defender = biff;
INectarCollector cutiePie = berthas;
```

These two statements use interfaces to create new references to existing objects. You can only point an interface reference at an instance of a class that implements it.

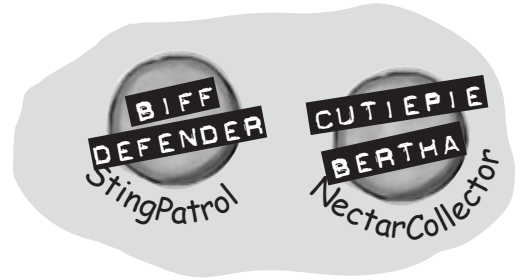

3 An interface reference will keep an object alive

When there aren't any references pointing to an object, it disappears. But there's no rule that says those references all have to be the same type! An interface reference is just as good as an object reference when it comes to keeping track of objects.

```
biff = null;
```

This object didn't disappear because *defender* is still pointing to it.

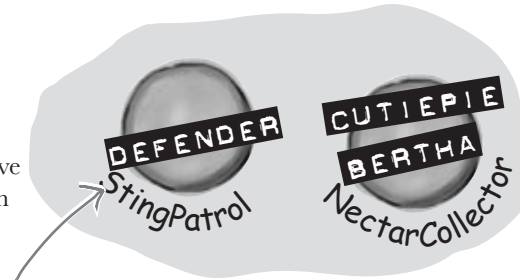

4 Assign a new instance to an interface reference

You don't actually *need* an object reference—you can create a new object and assign it straight to an interface reference variable.

```
INectarCollector gatherer = new NectarStinger();
```

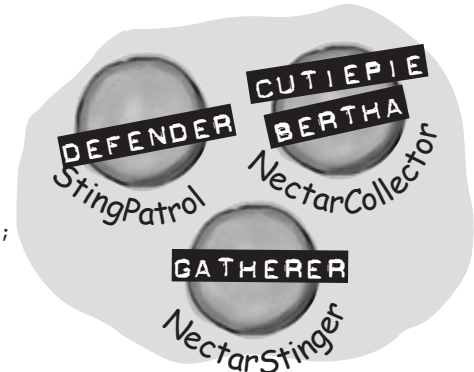

You can find out if a class implements a certain interface with "is"

Sometimes you need to find out if a certain class implements an interface. Suppose we have all our worker bees in an array, called Bees. We can make the array hold the type Worker, since all worker bees will be Worker classes, or subclasses of that type.

But which of the worker bees can collect nectar? In other words, we want to know if the class implements the INectarCollector interface. We can use the **is** keyword to find out exactly that.

```

Worker[] Bees = new Worker[3];
Bees[0] = new NectarCollector();
Bees[1] = new StingPatrol();
Bees[2] = new NectarStinger();
for (int i = 0; i < Bees.Length; i++)
{
    if (Bees[i] is INectarCollector)
    {
        Bees[i].DoThisJob("Nectar Collector", 3);
    }
}

```

All the workers are in an array of Workers. We'll use "is" to sort out which type of worker each bee is.

We've got an array of Worker bees who are all eligible to go on a nectar collecting mission. So we'll loop through the array, and use "is" to figure out which ones have the right methods and properties to do the job.

is works like an equals operator (==) for interfaces

This is like saying, if this bee implements the INectarCollector interface... do this.

Now that we know the bee is a nectar collector, we can assign it the job of collecting nectar.

there are no Dumb Questions

Q: Wait a minute. When I put a property in an interface, it looks just like an automatic property. Does that mean I can only use automatic properties when I implement an interface?

A: No, not at all. Yes, a property inside an interface looks very similar to an automatic property—like Job and Left in IWorker interface on the next page. But they're definitely not automatic properties. You could use implement Job like this:

```

public Job { get; private set; }

```

You need that private set, because automatic properties require you to have both a set and a get (even if they're private). But you could also implement it like this:

```

public job { get { return "Accountant"; } }

```

and the compiler will be perfectly happy with that, too. You can also add a set accessor—the interface requires a get, but it doesn't say you can't have a set, too. (If you use an automatic property to implement it, you can decide for yourself whether you want the set to be private or public.)

BRAIN POWER

If you have some other class that doesn't inherit from Worker but **does** implement the INectarCollector interface, then it'll be able to do the job, too! But since it doesn't inherit from Worker, you can't get it into an array with other bees. Can you think of a way to get around the problem and create an array with both bees and this new class?

Interfaces can inherit from other interfaces

When one class inherits from another, it gets all of the methods and properties from the base class. **Interface inheritance** is even simpler. Since there's no actual method body in any interface, you don't have to worry about calling base constructors or methods. The inherited interfaces simply accumulate all of the methods and properties from the interfaces they inherit from.

When we draw an interface on a class diagram, we'll show inheritance using dashed lines.

```
public interface IWorker
{
    string Job { get; }
    int Left { get; }
    void DoThisJob(string Job, int Shifts)
    void WorkOneShift()
}
```

We've created a new IWorker interface that the other interfaces inherit from.

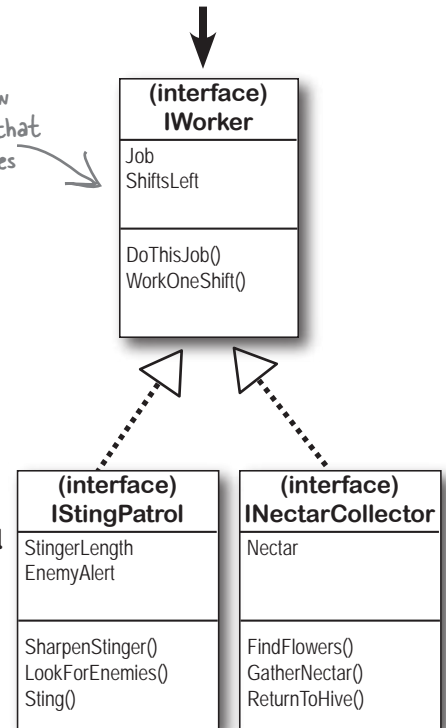

Any class that implements an interface that inherits from IWorker must implement its methods and properties

When a class implements an interface, it has to include every property and method in that interface. And if that interface inherits from another one, then all of *those* properties and methods need to be implemented, too.

```
public interface IStingPatrol : IWorker
{
    int AlertLevel { get; }
    int StingerLength { get; set; }
    bool LookForEnemies();
    int SharpenStinger(int Length);
}
```

Here's the same IStingPatrol interface, but now it inherits from the IWorker interface. It looks like a tiny change, but it makes a huge difference in any class that implements IStingPatrol.

A class that implements IStingPatrol must not only implement these methods...

...but the methods of the IWorker interface this interface inherits from, too.

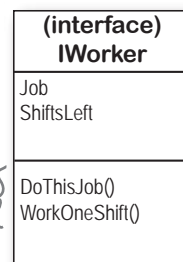

The RoboBee 4000 can do a worker bee's job without using valuable honey

Let's create a new bee, a RoboBee 4000, that runs on gas. We can have it inherit from the IWorker interface, though, so it can do everything a normal worker bee can.

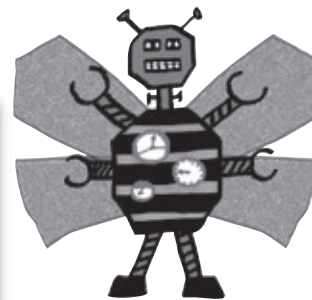

RoboBee
ShiftsToWork
ShiftsWorked
ShiftsLeft
Job
DoThisJob()

```
public class Robot
{
    public void ConsumeGas() {...}
}
```

This is our basic Robot class, so robots can run on gasoline.

The RoboBee class inherits from Robot and implements IWorker. That means it's a robot, but can do the job of a worker bee. Perfect!

```
public class RoboBee : Robot, IWorker
{
```

```
    private int shiftsToWork;
    private int shiftsWorked;
    public int ShiftsLeft
        {get {return shiftsToWork - shiftsWorked;}}
    private string job;
    public string Job;{get{return job;}}
    public bool DoThisJob(string Job, int shiftsToWork){...}
    public void WorkOneShift() {...}
}
```

The RoboBee class implements all the methods from the IWorker interface.

If RoboBee didn't implement everything in the IWorker interface, the code wouldn't compile.

Remember, for other classes in the application, there's no functional difference between a RoboBee and a normal worker bee. They both implement the IWorker interface, so both act like worker bees as far as the rest of the program is concerned.

But, you could distinguish between the types by using `is`:

```
if (workerBee is Robot) {
    // now we know workerBee
    // is a Robot object
}
```

We can see what class or interface workerBee implements or subclasses with "is."

Any class can implement **ANY** interface as long as it keeps the promise of implementing the interface's methods and properties.

is tells you what an object implements, as tells the compiler how to treat your object

Sometimes you need to call a method that an object gets from an interface it implements. But what if you don't know if that object is the right type? You use **is** to find that out. Then, you can use **as** to treat that object—which you now know is the right type—as having the method you need to call.

```
IWorker[] Bees = new IWorker[3];
    Bees[0] = new NectarStinger();
    Bees[1] = new RoboBee();
    Bees[2] = new Worker();
```

All these bees implement `IWorker`, but we don't know which ones implement other interfaces, like `INectarCollector`.

We're looping through each bee...

```
for (int i = 0; i < Bees.Length; i++) {
    if (Bees[i] is INectarCollector) {
        INectarCollector thisCollector;
        thisCollector = Bees[i] as INectarCollector;
        thisCollector.GatherNectar();
    }
}
```

We can't call `INectarCollector` methods on the bees. They're of type `IWorker`, and don't know about `INectarCollector` methods.

...and checking to see if it implements `INectarCollector`.

We use "as" to say, treat this object AS an `INectarCollector` implementation.

NOW we can call `INectarCollector` methods.

Sharpen your pencil

Take a look at the array on the left. For each of these statements, write down which values of `i` would make it evaluate to true. Also, two of them won't compile—cross those lines out.

```
IWorker[] Bees = new IWorker[8];
Bees[0] = new NectarStinger();
Bees[1] = new RoboBee();
Bees[2] = new Worker();
Bees[3] = Bees[0] as IWorker;
Bees[4] = IStingPatrol;
Bees[5] = null;
Bees[6] = Bees[0];
Bees[7] = new INectarCollector();
```

1. `(Bees[i] is INectarCollector)`
.....
2. `(Bees[i] is IStingPatrol)`
.....
3. `(Bees[i] is IWorker)`
.....

A CoffeeMaker is also an Appliance

If you're trying to figure out how to cut down your energy bill each month, you don't really care what each of your appliances does. You only really care that they consume power. So if you were writing a program to monitor your electricity consumption, you'd probably just write an Appliance class. But if you needed to be able to distinguish a coffee maker from an oven, you'd have to build a class hierarchy. So you'd add the methods and properties that are specific to a coffee maker or oven to some CoffeeMaker and Oven classes, and they'd inherit from an Appliance class that has their common methods and properties..

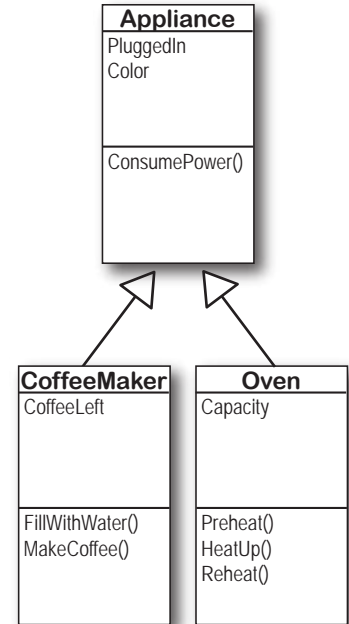

```

public void MonitorPower(Appliance appliance) {
    // code to add data to a household
    // power consumption database
}
    
```

This code would appear later on in the program to monitor the coffee maker's power consumption.

Here's a method in the program to monitor the power consumption for a house.

```

CoffeeMaker misterCoffee = new CoffeeMaker();
MonitorPower(misterCoffee);
    
```

Even though the MonitorPower() method takes a reference to an Appliance object, you can pass it the misterCoffee reference because CoffeeMaker is a subclass of Appliance.

You already saw this in the last chapter, when you saw how you could pass a BLT reference to a method that expected a Sandwich.

Sharpen your pencil Solution

Take a look at the array on the left. For each of these statements, write down which values of *i* would make it evaluate to true. Also, two of them won't compile—cross them out.

```

IWorker[] Bees = new IWorker[8];
Bees[0] = new NectarStinger();
Bees[1] = new RoboBee();
Bees[2] = new Worker();
Bees[3] = Bees[0] as IWorker;
Bees[4] = IStingPatrol;
Bees[5] = null;
Bees[6] = Bees[0];
Bees[7] = new INectarCollector();
    
```

1. (Bees[i] is INectarCollector)
 0 and 6

2. (Bees[i] is IStingPatrol)
 0, 6

3. (Bees[i] is IWorker)
 0, 1, 2, 3, and 6

NectarStinger() implements the IStingPatrol interface.

Upcasting works with both objects and interfaces

When you substitute a subclass for a base class—like substituting a coffee maker for an appliance or a BLT for a sandwich—it’s called **upcasting**. It’s a really powerful tool that you get when you build class hierarchies. The only drawback to upcasting is that you can only use the properties and methods of the base class. In other words, when you treat a coffee maker like an appliance, you can’t tell it to make coffee or fill it with water. But you *can* tell whether or not it’s plugged in, since that’s something you can do with any appliance (which is why the `PluggedIn` property is part of the `Appliance` class).

1 Let’s create some objects

We can create a `CoffeeMaker` and `Oven` class as usual:

```
CoffeeMaker misterCoffee = new CoffeeMaker();
Oven oldToasty = new Oven();
```

We’ll start by instantiating an `Oven` object and a `CoffeeMaker` as usual.

2 What if we want to create an array of appliances?

You can’t put a `CoffeeMaker` in an `Oven[]` array, and you can’t put an `Oven` in a `CoffeeMaker[]` array. But you can put both of them in an `Appliance[]` array:

```
Appliance[] kitchenWare = new Appliance[2];
kitchenWare[0] = misterCoffee;
kitchenWare[1] = oldToasty;
```

You can use upcasting to create an array of appliances that can hold both coffee makers and ovens.

3 But you can’t treat an appliance like an oven

When you’ve got an `Appliance` reference, you can **only** access the methods and properties that have to do with appliances. You **can’t** use the coffee maker methods and properties through the `Appliance` reference **even if you know it’s really a `CoffeeMaker`**. So these statements will work just fine, because they treat a `CoffeeMaker` object like an `Appliance`:

```
Appliance powerConsumer = new CoffeeMaker();
powerConsumer.ConsumePower();
```

But as soon as you try to use it like a `Coffee Maker`:

```
powerConsumer.MakeCoffee();
```

This line won’t compile because `powerConsumer` is an `Appliance` reference, so it can only be used to do `Appliance` things.

your code won’t compile, and the IDE will displays an error:

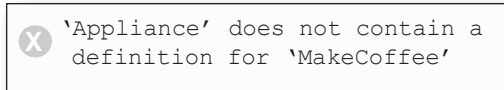

`powerConsumer` is an `Appliance` reference pointing to a `CoffeeMaker` object.



because once you upcast from a subclass to a base class, then you can only access the methods and properties that **match the reference** that you’re using to access the object.

Downcasting lets you turn your appliance back into a coffee maker

Upcasting is a great tool, because it lets you use a coffee maker or an oven anywhere you just need an appliance. But it's got a big drawback—if you're using an Appliance reference that points to a CoffeeMaker object, you can only use the methods and properties that belong to Appliance. And that's where **downcasting** comes in: that's how you take your **previously upcast reference** and change it back. You can figure out if your Appliance is really a CoffeeMaker using the **is** keyword. And once you know that, you can convert the Appliance back to a CoffeeMaker using the **as** keyword.

1 We'll start with the coffee maker we already upcast

Here's the code that we used:

```
Appliance powerConsumer = new CoffeeMaker();
powerConsumer.ConsumePower();
```

2 But what if we want to turn the Appliance back into a CoffeeMaker?

The first step in downcasting is using the **is** keyword to check if it's even an option.

```
if (powerConsumer is CoffeeMaker)
    // then we can downcast!
```

3 Now that we know it's a CoffeeMaker, let's use it like one

The **is** keyword is the first step. Once you know that you've got an Appliance reference that's pointing to a CoffeeMaker object, you can use **as** to downcast it. And that lets you use the CoffeeMaker class's methods and properties. And since CoffeeMaker inherits from Appliance, it still has its Appliance methods and properties.

```
if (powerConsumer is CoffeeMaker) {
    CoffeeMaker javaJoe = powerConsumer as CoffeeMaker;
    javaJoe.MakeCoffee();
}
```

Here's our Appliance reference that points to a CoffeeMaker object from the last page.



The javaJoe reference points to the same CoffeeMaker object as powerConsumer. But it's a CoffeeMaker reference, so it can call the MakeCoffee() method.



When downcasting fails, as returns null

So what happens if you try to use **as** to convert an Oven object into a CoffeeMaker? It returns null—and if you try to use it, .NET will cause your program to break.

```
if (powerConsumer is CoffeeMaker) {
    Oven foodWarmer = powerConsumer as Oven;
    foodWarmer.Preheat();
}
```

Uh-oh—these don't match!

powerConsumer is NOT an Oven object. So when you try to downcast it with "as", the foodWarmer reference ends up set to null. And when you try to use a null reference, this happens...

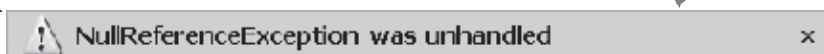

Upcasting and downcasting work with interfaces, too

You already know that `is` and `as` work with interfaces. Well, so do all of the upcasting and downcasting tricks. Let's add an `ICooksFood` interface for any class that can heat up food. And we'll add a `Microwave` class—both `Microwave` and `Oven` implement the `ICooksFood` interface. Now there are three different ways that you can access an `Oven` object. And the IDE's IntelliSense can help you figure out exactly what you can and can't do with each of them:

```
Oven misterToasty = new Oven();
misterToasty.
```

As soon as you type the dot, the IntelliSense window will pop up with a list of all of the members you can use.

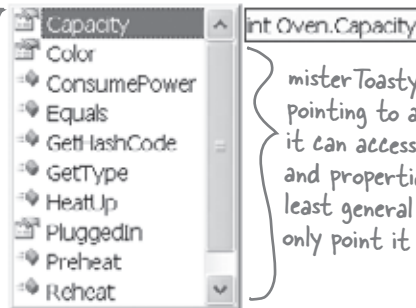

misterToasty is an Oven reference pointing to an Oven object, so it can access all of the methods and properties... but it's the least general type, so you can only point it at Oven objects.

```
ICooksFood cooker;
if (misterToasty is ICooksFood)
    cooker = misterToasty as ICooksFood;
cooker.
```

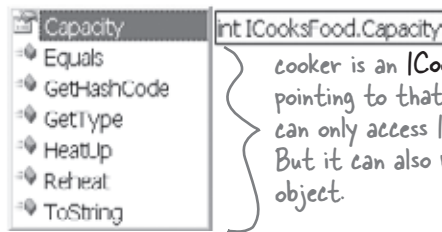

cooker is an ICooksFood reference pointing to that same Oven object. It can only access ICooksFood members. But it can also point to a Microwave object.

```
Appliance powerConsumer;
if (misterToasty is Appliance)
    powerConsumer = misterToasty;
powerConsumer.
```

powerConsumer is an Appliance reference. It only lets you get to the public fields, methods and properties in Appliance. You can also point it at a CoffeeMaker object if you want.

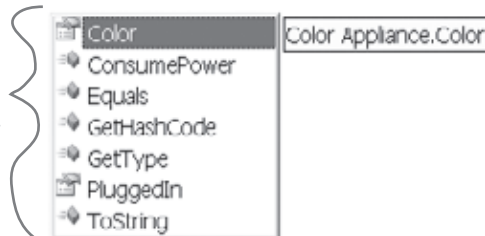

Any class that implements ICooksFood is an appliance that can heat up food.

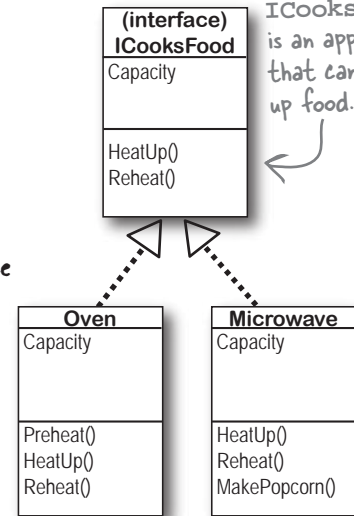

Three different references that point to the same object can access different methods and properties, depending on the reference's type.

there are no Dumb Questions

Q: So back up—you told me that I can always upcast but I can't always downcast. Why?

A: Because the compiler can warn you if your upcast is wrong. The only time an upcast won't work is if you're trying to set an object equal to a class that it doesn't inherit from or an interface that it doesn't implement. And the compiler can figure out immediately that you didn't upcast properly, and will give you an error.

On the other hand, the compiler doesn't know how to check if you're downcasting from an object or interface reference to a reference that's not valid. That's because it's perfectly legal to put any class or interface name on the right-hand side of the `as` keyword. If the downcast is illegal, then the `as` statement will just return `null`. And it's a good thing that the compiler doesn't stop you from doing that, because there are plenty of times when you'd want to do that.

Q: Someone told me that an interface is like a contract, but I don't really get why. What does that mean?

A: Yes, we've heard that too—a lot of people like to say that an interface is like a contract. (That's a really common question on job interviews.) And it's true, to some extent. When you make your class implement an interface, you're telling the compiler that you promise to put certain methods into it. The compiler will hold you to that promise.

But we think that it's easier to remember how interfaces work if you think of an interface as a kind of checklist. The compiler runs through the checklist to make sure that you actually put all of the methods from the interface into your class. If you didn't, it'll bomb out and not let you compile.

Q: What if I want to put a method body into my interface? Is that okay?

A: No, the compiler won't let you do that. An interface isn't allowed to have any statements in it at all. Even though you use the colon operator to implement an interface, it's not the same thing as inheriting from a class. Implementing an interface doesn't add any behavior to your class at all, or make any changes to it. All it does is tell the compiler to make sure that your class has all of the methods that the interface says it should have.

Q: Then why would I want to use an interface? It seems like it's just adding restrictions, without actually changing my class at all.

A: Because when your class implements an interface, then an interface reference can point to any instance of that class. And that's really useful to you—it lets you create one reference type that can work a whole bunch of different kinds of objects.

Here's a quick example. A horse, an ox, a mule, and a steer can all pull a cart. But in our zoo simulator, `Horse`, `Ox`, `Mule`, and `Steer` would all be different classes. Let's say you had a cart-pulling ride in your zoo, and you wanted to create an array of any animal that could pull carts around. Uh-oh—you can't just create an array that will hold all of those. If they all inherited from the same base class, then you could create an array of those. But it turns out that they don't. So what'll you do?

That's where interfaces come in handy. You can create an `IPuller` interface that has methods for pulling carts around. Now you could declare your array like this:

```
IPuller[] pullerArray;
```

Now you can put a reference to any animal you want in that array, as long as it implements the `IPuller` interface.

Q: Is there an easier way to implement interfaces? It's a lot of typing!

A: Why yes, there is! The IDE gives you a very powerful shortcut that automatically implements an interface for you. Just start typing your class:

```
public class
    Microwave : ICooksFood
    { }
```

Click on `ICooksFood`—you'll see a small bar appear underneath the "I". Hover over it and you'll see an icon appear underneath it:



Click on icon and choose "Implement Interface 'ICooksFood'" from the menu. It'll automatically add any members that you haven't implemented yet. Each one has a single `throws` statement in it—they'll cause your program to halt, as a reminder in case you forget to implement one of them (You'll learn about `throws` in chapter 10.)

An interface is like a checklist that the compiler runs through to make sure your class implemented a certain set of methods.



Exercise

Extend the IClown interface and use classes that implement it.

- Start with the IClown interface from the last “Do This!” on page 258

```
public interface IClown {
    string FunnyThingIHave { get; }
    void Honk();
}
```

- Extend IClown by creating a new interface, IScaryClown, that inherits from IClown. It should have an additional string property called ScaryThingIHave with a get accessor but no set accessor, and a void method called ScareLittleChildren().

- Create these classes:

- ★ A funny clown class called FunnyFunny that uses a private string variable to store a funny thing, and use a constructor that takes a parameter called funnyThingIHave and uses it to set the private field. The Honk () method should say, “Honk honk! I have a ” followed by the funny thing it has. The FunnyThingIHave set accessor should return the same thing.
- ★ A scary clown class called ScaryScary that uses a private variable to store an integer that was passed to it by its constructor in a parameter called numberOfScaryThings. The ScaryThingIHave get accessor should return a string consisting of the number from the constructor followed by “spiders”. The ScareLittleChildren () pops up a message box that says, “Boo! Gotcha!”

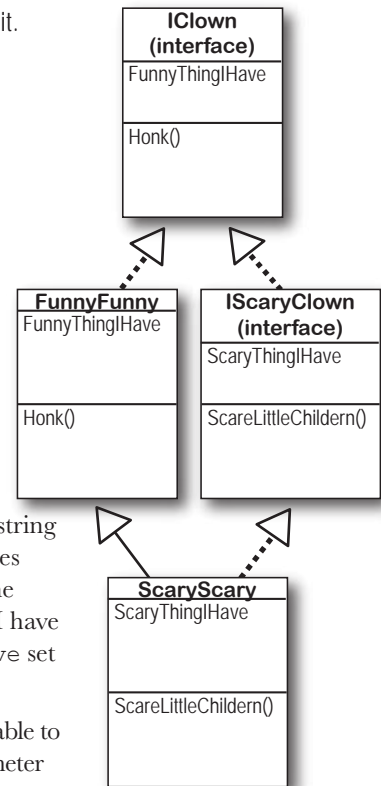

- Here’s code for a button—but it’s not working. Can you figure out how to fix it?

```
private void button1_Click(object sender, EventArgs e) {
    ScaryScary fingersTheClown = new ScaryScary("big shoes", 14);
    FunnyFunny someFunnyClown = fingersTheClown;
    IScaryClown someOtherScaryclown = someFunnyClown;
    someOtherScaryclown.Honk();
}
```

Fingers the Clown is scary.



You better get this one right... or else!



Exercise Solution

Extend the IClown interface and use classes that implement it.

```
public interface IClown {
    string FunnyThingIHave { get; }
    void Honk();
}

public interface IScaryClown : IClown {
    string ScaryThingIHave { get; }
    void ScareLittleChildren();
}

public class FunnyFunny : IClown {
    public FunnyFunny(string funnyThingIHave) {
        this.funnyThingIHave = funnyThingIHave;
    }
    private string funnyThingIHave;
    public string FunnyThingIHave {
        get { return "Honk honk! I have " + funnyThingIHave; }
    }
    public void Honk() {
        MessageBox.Show(this.FunnyThingIHave);
    }
}

public class ScaryScary : FunnyFunny, IScaryClown {
    public ScaryScary(string funnyThingIHave, int numberOfScaryThings)
        : base(funnyThingIHave) {
        this.numberOfScaryThings = numberOfScaryThings;
    }
    private int numberOfScaryThings;
    public string ScaryThingIHave {
        get { return "I have " + numberOfScaryThings + " spiders"; }
    }
    public void ScareLittleChildren() {
        MessageBox.Show("Boo! Gotcha!");
    }
}

private void button1_Click(object sender, EventArgs e) {
    ScaryScary fingersTheClown = new ScaryScary("big shoes", 14);
    FunnyFunny someFunnyClown = fingersTheClown;
    IScaryClown someOtherScaryClown = someFunnyClown as ScaryScary;
    someOtherScaryClown.Honk();
}
```

The Honk() method just uses this set accessor to display its message—no need to have the same code twice.

You could have implemented the IClown method and property again, but why not just inherit from FunnyFunny?

Since ScaryScary is a subclass of FunnyFunny and FunnyFunny implements IClown, ScaryScary implements IClown too.

You can set a FunnyFunny reference equal to a ScaryScary object because ScaryScary inherits from FunnyFunny. But you can't set any IScaryClown reference to just any clown, because you don't know if that clown is scary. That's why you need to use the `as` keyword.

You can also use the `someOtherScaryClown` reference to call `ScareLittleChildren()`—but you can't get to it from the `someFunnyClown` reference.

There's more than just public and private

You already know how important the `private` keyword is, how you use it, and how it's different from `public`. C# has a name for them: they're called **access modifiers**. The name makes sense, because when you change an access modifier on a property, field, or method of a class—its **members**—or the entire class, you change the way other classes can access it. There are a few more access modifiers that you'll use, but we'll start with the ones you know:

We call a class's methods, fields and properties its **members**. Any member can be marked with the `public` or `private` access modifier.

★ **public means that anyone can access it**

When you mark a class or class member `public`, you're telling C# that any instance of any other class can access it. It's the least restrictive access modifier. And you've already seen how it can get you in trouble—only mark class members `public` if you have a reason. That's how you make sure your classes are well-encapsulated.

★ **private means that only other members can access it**

When you mark a class member `private`, then it can only be accessed from other members inside that class or **other instances of that class**. You can't mark a class `private`—unless that class **lives inside another class**, in which case it's only available to instances of its container class. Then it's `private` by default, and if you want it to be `public` you need to mark it `public`.

If you leave off the access modifier when you declare a class member, it defaults to `private`.

★ **protected means public to subclasses, private to everyone else**

You've already seen how a subclass can't access the private fields in its base class—it has to use the `base` keyword to get to the public members of the base object. Wouldn't it be convenient if the subclass could access those private fields? That's why you have the `protected` access modifier. Any class member marked `protected` can be accessed by any other member of its class, and any member of a subclass of its class.

If you leave off the access modifier when you declare a class or an interface, then by default it's set to `internal`. And that's just fine for most classes—it means that any other class in the assembly can read it. If you're not using multiple assemblies, `internal` will work just as well as `public` for classes and interfaces. Give it a shot—go to an old project, change some of the classes to `internal`, and see what happens.

★ **internal means public only to other classes in an assembly**

The built-in .NET Framework classes are **assemblies**—libraries of classes that are in your project's list of references. You can see a list of assemblies by right-clicking on "References" in the Solution Explorer and choosing "Add Reference..."—when you create a new Windows Forms Application, the IDE automatically includes the references you need to build a Windows application. When you build an assembly, you can use the `internal` keyword to keep classes private to that assembly, so you can only expose the classes you want. You can combine this with `protected`—anything you mark `protected internal` can only be accessed from within the assembly **or** from a subclass.

★ **sealed says that this class can't be subclassed**

There are some classes which you just can't inherit from. A lot of the .NET Framework classes are like this—go ahead, try to make a class that inherits from `String` (that's the class whose `IsEmptyOrNull()` method you used in the last chapter.) What happens? The compiler won't let you build your code—it gives you the error, "cannot derive from sealed type 'string'". You can do that with your own classes—just add `sealed` after the access modifier.

Sealed is a modifier, but it's not an access modifier. That's because it only affects inheritance—it doesn't change the way class can be accessed.

Access modifiers change scope

Let's take a closer look at the access modifiers, and how they affect the **scope** of the various class members. We made two changes: the funnyThingIHave backing field is now `protected`, and we changed the ScareLittleChildren() method so that it uses the funnyThingIHave field:

Make these two changes to your own exercise solution. Then change the protected access modifier back to private and see what errors you get.

- Here are two interfaces. `IClown` defines a clown who honks his horn and has a funny thing. `IScaryClown` inherits from `clown`. A scary clown does everything a clown does, plus he has a scary thing and scares little children.

```
public interface IClown {
    string FunnyThingIHave { get; }
    void Honk();
}

public interface IScaryClown : IClown {
    string ScaryThingIHave { get; }
    void ScareLittleChildren();
}
```

The "this" keyword also changes the scope of a variable. It says to C#, "Look at the current instance of the class to find whatever I'm connected to—even if that matches a parameter or local variable."

This is a really common way to use "this", since the parameter and backing field have the same name. `funnyThingIHave` refers to the parameter, while `this.funnyThingIHave` is the backing field.

- The `FunnyFunny` class implements the `IClown` interface. We made the `funnyThingIHave` field `protected` so that it can be accessed by any instance of a subclass of `FunnyFunny`.

```
public class FunnyFunny : IClown {
    public FunnyFunny(string funnyThingIHave) {
        this.funnyThingIHave = funnyThingIHave;
    }
    protected string funnyThingIHave;
    public string FunnyThingIHave {
        get { return "Honk honk! I have " + funnyThingIHave; }
    }

    public void Honk() {
        MessageBox.Show(this.FunnyThingIHave);
    }
}
```

By adding "this", we told C# that we're talking about the backing field, not the parameter that has the same name.

We changed this to `protected`. Look and see how it affects the `ScaryScary.ScareLittleChildren()` method.

When you use "this" with a property, it tells C# to execute the set or get accessor.

3 The ScaryScary class implements the IScaryClown interface. It also inherits from FunnyFunny, and since FunnyFunny implements IClown, that means ScaryScary does, too. Take a look at how the ScareLittleChildren() method accesses the funnyThingIHave backing field—it can do that because we used the protected access modifier. If we'd made it private instead, then this code wouldn't compile.

Access Modifiers Up Close



numberOfScaryThings is private, which is typical of a backing field. So only another instance of ScaryScary would be able to see it.

```
public class ScaryScary : FunnyFunny, IScaryClown {
    public ScaryScary(string funnyThingIHave,
        int numberOfScaryThings)
        : base(funnyThingIHave) {
        this.numberOfScaryThings = numberOfScaryThings;
    }

    private int numberOfScaryThings;
    public string ScaryThingIHave {
        get { return "I have " + numberOfScaryThings + " spiders"; }
    }

    public void ScareLittleChildren() {
        MessageBox.Show("You can't have my "
            + base.funnyThingIHave);
    }
}
```

The "base" keyword tells C# to use the value from the base class. That's another way to change scope.

The protected keyword tells C# to make something private to everyone except instances of a subclass.

If we'd left funnyThingIHave private, this would cause the compiler to give you an error. But when we changed it to protected, that made it visible to any subclass of FunnyFunny.

4 Here's a button that instantiates FunnyFunny and ScaryScary. Take a look at how it uses as to downcast someFunnyClown to an IScaryClown reference.

```
private void button1_Click(object sender, EventArgs e) {
    ScaryScary fingersTheClown = new ScaryScary("big shoes", 14);
    FunnyFunny someFunnyClown = fingersTheClown;
    IScaryClown someOtherScaryclown = someFunnyClown as ScaryScary;
    someOtherScaryclown.Honk();
}
```

Since this button click event handler is not part of FunnyFunny and ScaryScary, it can't access the protected funnyThingIHave field.

It's outside of both classes, so the statements inside it only have access to the public members of any FunnyFunny or ScaryScary objects.

there are no Dumb Questions

Q: Why would I want to use an interface instead of just writing all of the methods I need directly into my class?

A: You might end up with a lot of different classes as you write more and more complex programs. Interfaces let you group those classes by the kind of work they do. They help you be sure that every class that's going to do a certain kind of work does it using the same methods. The class can do the work however it needs to and, because of the interface, you don't need to worry about how it does it just to get the job done.

Here's an example: you can have a truck class and a sailboat class that implement `ICarryPassenger`. Say the `ICarryPassenger` interface stipulates that any class that implements it has to have a `ConsumeEnergy()` method. Your program could use them both to carry passengers even though the sailboat class's `ConsumeEnergy()` method uses wind power and the truck class's method uses diesel fuel.

Imagine if you didn't have the `ICarryPassenger` interface. Then it would be tough to tell your program which vehicles could carry people and which couldn't. You would have to look through each class that your program might use and figure out whether or not there was a method for carrying people from one place to another. Then you'd have to call each of the vehicles your program was going to use with whatever method was defined for carrying passengers. And since there's no standard interface, they could be named all sorts of things or buried inside other methods. You can see how that'll get confusing pretty fast.

Q: Why do I need to use a property? Can't I just include a field?

A: Good question. An interface only defines the way a class should do a specific kind of job. It's not an object by itself, so you can't instantiate it and it can't store information. If you added a field that was just a variable declaration, then `C#` would have to store that data somewhere—and an interface can't store data by itself. A property is a way to make something that looks like a field to other objects, but since it's really a method, it doesn't actually store any data.

Q: What's the difference between a regular object reference and an interface reference?

A: You already know how a regular, everyday object reference works. If you create an instance of `Skateboard` called `VertBoard`, and then a new reference to it called `HalfPipeBoard`, they both point to the same thing. But if `Skateboard` implements the interface `IStreetTricks` and you create an interface reference to `Skateboard` called `StreetBoard`, it will only know the methods in the `Skateboard` class that are also in the `IStreetTricks` interface.

All three references are actually pointing to the same object. If you call the object using the `HalfPipeBoard` or `VertBoard` references, you'll be able to access any method or property in the object. If you call it using the `StreetBoard` reference, you'll only have access to the methods and properties in the interface.

Q: Then why would I ever want to use an interface reference if it limits what I can do with the object?

A: Interface references give you a way of working with a bunch of different kinds of objects that do the same thing. You can create an array using the interface reference type that will let you pass information to and from the methods in `ICarryPassenger` whether your working with a truck object, a horse object, a unicycle object, or a car object. The way each of those objects do the job is probably a little different, but with interface references, you know that they all have the same methods that take the same parameters and have the same return types. So, you can call them and pass information to them in exactly the same way.

Q: Why would I make something protected instead of private or public?

A: Because it helps you encapsulate your classes better. There are a lot of times that a subclass needs access to some internal part of its base class. For example, if you need to override a property, it's pretty common to use the backing field in the base class in the get accessor, so that it returns some sort of variation of it. But when you build classes, you should only make something public if you have a reason to do it. Using the protected access modifier lets you expose it only to the subclass that needs it, and keep it private to everyone else.

Interface references only know about the methods and properties that are defined in the interface.

Some classes should never be instantiated

Remember our zoo simulator class hierarchy? You'll definitely end up instantiating a bunch of hippos, dogs and lions. But what about the Canine and Feline classes? How about the Animal class? It turns out that there are some classes that just don't need to be instantiated... and, in fact, don't make any sense if they are. Here's an example.

Let's start with a basic class for a student shopping at the student bookstore.

```
public class Shopper {
    public void ShopTillYouDrop()
        while (TotalSpent < CreditLimit)
            BuyFavoriteStuff();
}
public virtual void BuyFavoriteStuff () {
    // No implementation here - we don't know
    // what our student likes to buy!
}
}
```

Here's the ArtStudent class—it subclasses Shopper:

```
public class ArtStudent : Shopper {
    public override void BuyFavoriteStuff () {
        BuyArtSupplies();
        BuyBlackTurtlenecks();
        BuyDepressingMusic();
    }
}
```

And the EngineeringStudent class also inherits from Shopper:

```
public class EngineeringStudent : Shopper {
    public override void BuyFavoriteStuff () {
        BuyPencils();
        BuyGraphingCalculator();
        BuyPocketProtector();
    }
}
```

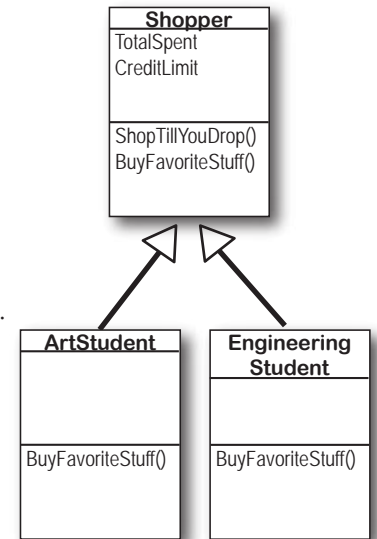

The ArtStudent and EngineeringStudent classes both override the BuyFavoriteStuff() method, but they buy very different things.

So what happens when you instantiate Shopper? Does it ever make sense to do it?

An abstract class is like a cross between a class and an interface

Suppose you need something like an interface, that requires classes to implement certain methods and properties. But you need to include some code in that interface, so that certain methods don't have to be implemented in each inheriting class. What you want is an **abstract class**. You get the features of an interface, but you can write code in it like a normal class.

★ **An abstract class is like a normal class**

You define an abstract class just like a normal one. It has fields and methods, and you can inherit from other classes, too, exactly like with a normal class. There's almost nothing new to learn here, because you already know everything that an abstract class does!

A method that has a declaration but no statements or method body is called an **abstract method**. Inheriting classes must implement all abstract methods, just like when they inherit from an interface.



Only abstract classes can have abstract methods. If you put an abstract method into a class, then you'll have to mark that class **abstract** or it won't compile. You'll learn more about how to mark a class **abstract** in a minute.

★ **An abstract class is like an interface**

When you create a class that implements an interface, you agree to implement all of the properties and methods defined in that interface. An abstract class works the same way—it can include declarations of properties and methods that, just like in an interface, must be implemented by inheriting classes.



★ **But an abstract class can't be instantiated**

The biggest difference between an **abstract** class and a **concrete** class is that you can't use `new` to create an instance of an abstract class. If you do, C# will give you an error when you try to compile your code.

The opposite of abstract is **concrete**. A concrete method is one that has a body, and all the classes you've been working with so far are concrete classes.



✘ Cannot create an instance of the abstract class or interface 'MyClass'



This error is because you have abstract methods without any code! The compiler won't let you instantiate a class with missing code, just like it wouldn't let you instantiate an interface.



Wait, what? A class that I can't instantiate?
Why would I even want something like that?

Because you want to provide some code, but still require that subclasses fill in the rest of the code.

Sometimes **bad things happen** when you create objects that should never be created. The class at the top of your class diagram usually has some fields that it expects its subclasses to set. An Animal class may have a calculation that depends on a boolean called HasTail or Vertebrate, but there's no way for it to set that itself.

Here's a class that the Objectville Astrophysics Club uses to send their rockets to different planets.

Here's an example...

The astrophysicists have two missions—one to Mars, and one to Venus.

```
public class PlanetMission {
    public long RocketFuelPerMile;
    public long RocketSpeedMPH;
    public int MilesToPlanet;

    public long UnitsOfFuelNeeded() {
        return MilesToPlanet * RocketFuelPerMile;
    }

    public int TimeNeeded() {
        return MilesToPlanet / (int) RocketSpeedMPH;
    }

    public string FuelNeeded() {
        return "You'll need "
            + MilesToPlanet * RocketFuelPerMile
            + " units of fuel to get there. It'll take "
            + TimeNeeded() + " hours.";
    }
}
```

It doesn't make sense to set these fields in the base class, because we don't know what rocket or planet we'll be using.

```
public class Venus : PlanetMission {
    public Venus() {
        MilesToPlanet = 40000000;
        RocketFuelPerMile = 100000;
        RocketSpeedMPH = 25000;
    }
}

public class Mars : PlanetMission {
    public Mars() {
        MilesToPlanet = 75000000;
        RocketFuelPerMile = 100000;
        RocketSpeedMPH = 25000;
    }
}
```

The constructors for the Mars and Venus subclasses set the three fields they inherited from Planet. But those fields won't get set if you instantiate Planet directly. So what happens when FuelNeeded() tries to use them?

```
private void button1_Click(object s, EventArgs e) {
    Mars mars = new Mars();
    MessageBox.Show(mars.FuelNeeded());
}

private void button2_Click(object s, EventArgs e) {
    Venus venus = new Venus();
    MessageBox.Show(venus.FuelNeeded());
}

private void button3_Click(object s, EventArgs e) {
    PlanetMission planet = new PlanetMission();
    MessageBox.Show(planet.FuelNeeded());
}
```

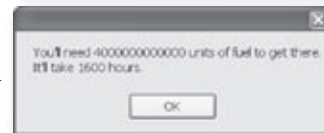
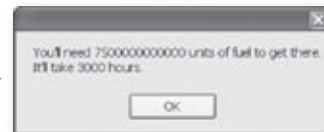

Before you flip the page, try to figure out what will happen when the user clicks the third button...

Like we said, some classes should never be instantiated

The problems all start when you create an instance of the PlanetMission class. Its FuelNeeded() method expects the fields to be set by the subclass. But when they aren't, they get their default values—zero. And when C# tries to divide a number by zero...

```
private void button3_Click(object s, EventArgs e) {
    PlanetMission planet = new PlanetMission();
    MessageBox.Show(planet.FuelNeeded());
}
```

The PlanetMission class wasn't written to be instantiated. We were only supposed to inherit from it. But we did, and that's where the problems started.

When the FuelNeeded() method tried to divide by RocketSpeedMPH, it was zero. And when you divide by zero, this happens.

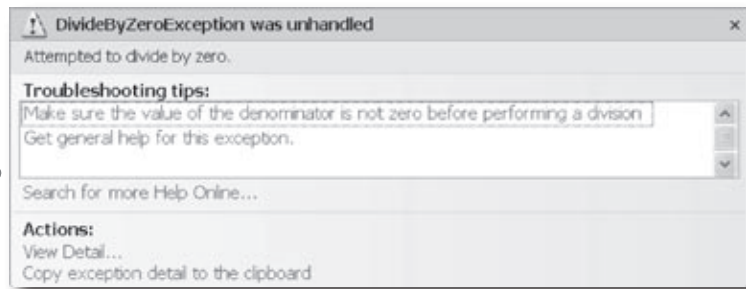

Solution: use an abstract class

When you mark a class abstract, C# won't let you write code to instantiate it. It's a lot like an interface—it acts like a template for the classes that inherit from it.

Adding the abstract keyword to the class declaration tells C# this is an abstract class, and can't be instantiated.

Now C# will refuse to compile our program until we remove the line that creates an instance of PlanetMission.

```
public abstract class PlanetMission {
    public long RocketFuelPerMile;
    public long RocketSpeedMPH;
    public int MilesToPlanet;

    public long UnitsOfFuelNeeded() {
        return MilesToPlanet * RocketFuelPerMile;
    }

    // the rest of the class is defined here
}
```



Flip back to the solution to Kathleen's party planning program in the previous chapter on pages 236–238—take another look at the encapsulation problems that we left in the code. Can you figure out how you'd use an abstract class to solve them?

An abstract method doesn't have a body

You know how an interface only has declarations for methods and properties, but it doesn't actually have any method bodies? That's because every method in an interface is an **abstract method**. So let's implement it! Once we do, the error will go away. Any time you extend an abstract class, you need to make sure that you override all of its abstract methods. Luckily, the IDE makes this job easier. Just type "public override"—as soon as you press space, the IDE will display a dropdown box with a list of any methods that you can override. Select the SetMissionInfo method and fill it in:

```
public abstract class PlanetMission {
```

```
    public abstract void SetMissionInfo(
        int MilesToPlanet, int RocketFuelPerMile,
        long RocketSpeedMPH);

    // the rest of the class...
```

This abstract method is just like what you'd see in an interface—it doesn't have a body, but any class that inherits from PlanetMission has to implement the SetMissionInfo() method or the program won't compile.

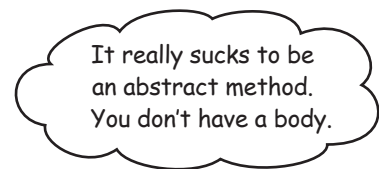

o o

If we add that method in and try to build the program, the IDE gives us an error:

```
x 'VenusMission' does not implement inherited abstract member 'PlanetMission.SetMissionInfo(long, int, int)'
```

So let's implement it! Once we do, the error will go away.

```
public class Venus : PlanetMission {
    public Venus() {
        SetMissinInfo(40000000, 100000, 25000);
    }
    public override SetMissionInfo(int milesToPlanet, long rocketFuelPerMile,
        int rocketSpeedMPH) {
        this.MilesToPlanet = milesToPlanet;
        this.RocketFuelPerMile = rocketFuelPerMile;
        this.RocketSpeedMPH = rocketSpeedMPH;
    }
}
```

When you inherit from an abstract class, you need to override all of its abstract methods.





Here's your chance to demonstrate your artistic abilities. On the left you'll find sets of class and interface declarations. Your job is to draw the associated class diagrams on the right. We did the first one for you. Don't forget to use a dashed line for implementing an interface and a solid line for inheriting from a class.

Given:

1) `public interface Foo { }`
`public class Bar : Foo { }`

2) `public interface Vinn { }`
`public abstract class Vout : Vinn { }`

3) `public abstract class Muffie : Whuffie { }`
`public class Fluffie : Muffie { }`
`public interface Whuffie { }`

4) `public class Zoop { }`
`public class Boop : Zoop { }`
`public class Goop : Boop { }`

5) `public class Gamma : Delta, Epsilon { }`
`public interface Epsilon { }`
`public interface Beta { }`
`public class Alpha : Gamma, Beta { }`
`public class Delta { }`

What's the Picture ?

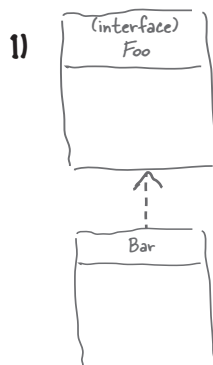

2)

3)

4)

5)

On the left you'll find sets of class diagrams. Your job is to turn these into valid C# declarations. We did number 1 for you.

Given:

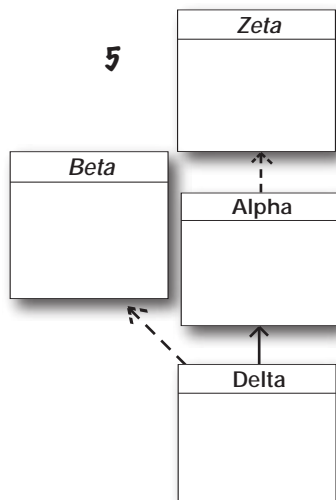
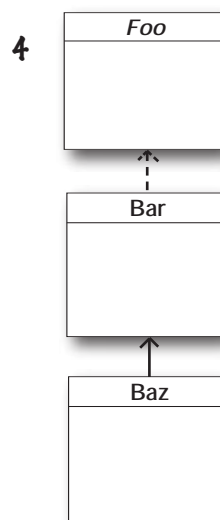
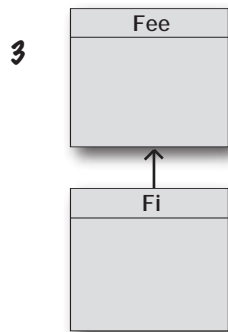
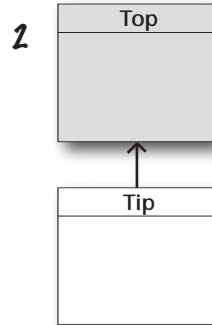
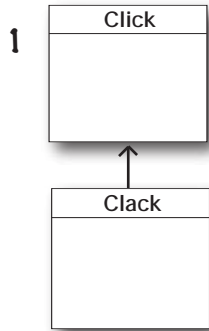

What's the Declaration ?

```
1) public class Click { }
   public class Clack : Click { }
```

2)

3)

4)

5)

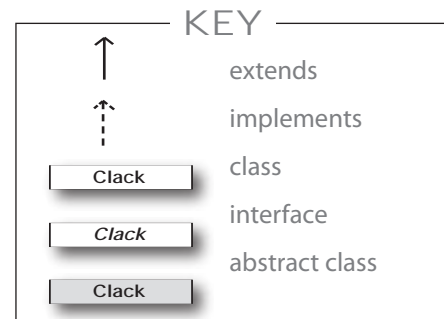

Fireside Chats



Tonight's talk: **An abstract class and an interface butt heads over the pressing question, "Who's more important?"**

Abstract Class:

I think it's obvious who's more important between the two of us. Programmers need me to get their jobs done. Let's face it. You don't even come close.

You can't really think you're more important than me. You don't even use real inheritance—you only get implemented.

Better? You're nuts. I'm much more flexible than you. I can have abstract methods or concrete ones. I can even have virtual methods if I want. Sure, I can't be instantiated but then, neither can you. And I can do pretty much anything else a regular class does.

Interface:

Nice. This oughta be good.

Great, here we go again. Interfaces don't use real inheritance. Interfaces only implement. That's just plain ignorant. Implementation is as good as inheritance, in fact it's better!

Yeah? What if you want a class that inherits from you *and* your buddy? **You can't inherit from two classes.** You have to choose which class to inherit from. And that's just plain rude! There's no limit to the number of interfaces a class can implement. Talk about flexible! With me, a programmer can make a class do anything.

Sharpen your pencil Solution

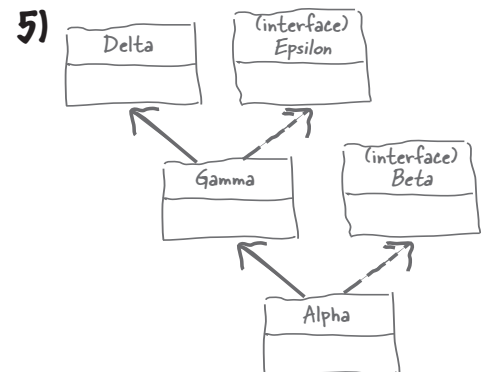
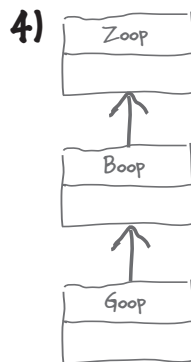
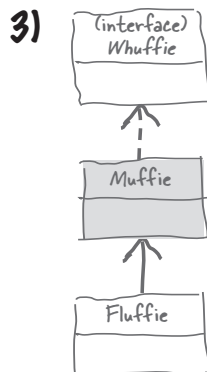
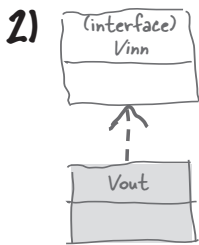

What's the Picture ?

Abstract Class:

You might be overstating your power a little bit.

That's exactly the kind of drivel I'd expect from an interface. Code is extremely important! It's what makes your programs run.

Really? I doubt that—programmers always care what's in their properties and methods.

Yeah, sure, tell a coder he can't code.

Interface:

You think that just because you can contain code, you're the greatest thing since sliced bread. But you can't change the fact that a program can only inherit from one class at a time. So, you're a little limited. Sure, I can't include any code. But really, code is overrated.

Nine times out of ten, a programmer wants to make sure an object has certain properties and methods, but doesn't really care how they're implemented.

Okay, sure. Eventually. But think about how many times you've seen a programmer write a method that takes an object that just needs to have a certain method, and it doesn't really matter right at that very moment exactly how the method's built. Just that it's there. So bang! The programmer just needs to write an interface. Problem solved!

Whatever!

```
2) public abstract class Top { }
   public class Tip : Top { }
```

```
4) public interface Foo { }
   public class Bar : Foo { }
   public class Baz : Bar { }
```

```
3) public abstract class Fee { }
   public abstract class Fi : Fee { }
```

```
5) public interface Zeta { }
   public class Alpha : Zeta { }
   public interface Beta { }
   public class Delta : Alpha, Beta { }
```

Delta inherits from Alpha and implements Beta.

What's the Declaration ?



I'm still hung up on not being able to inherit from two classes. If I can't inherit from more than one class, so I have to use interfaces. That's a pretty big limitation of C#, right?

It's not a limitation, it's a protection.

If C# let you inherit from more than one base class, it would open up a whole can of worms. When a language lets one subclass inherit from two base classes, it's called **multiple inheritance**. And by giving you interfaces instead, C# saves you from a big fat mess that we like to call...

The Deadly Diamond of Death!

Television and MovieTheater both inherit from MoviePlayer, and both override the ShowAMovie() method. Both inherit the ScreenWidth property, too.

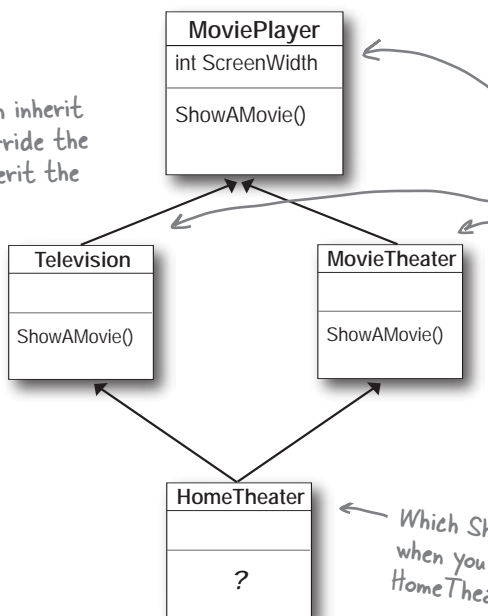

Imagine that the ScreenWidth property is used by both Television and MovieTheater, with different values. What happens if HomeTheater needs to use both values of ScreenWidth—say, to show both made-for-TV movies and feature films?

Which ShowAMovie() method runs when you call ShowAMovie() on the HomeTheater object?

Avoid ambiguity!

A language that allows the Deadly Diamond of Death can lead to some pretty ugly situations, because you need special rules to deal with this kind of ambiguous situation... which means extra work for you when you're building your program! C# protects you from having to deal with this by giving you interfaces. If Television and MovieTheater are interfaces instead of classes, then the same ShowAMovie() method can satisfy both of them. All the interface cares about is that there's some method called ShowAMovie().



Pool Puzzle

Your **job** is to take code snippets from the pool and place them into the blank lines in the code and output. You may use the same snippet more than once, and you won't need to use all the snippets. Your **goal** is to make a set of classes that will compile and run and produce the output listed.

```
public ..... Nose {
    .....;
    string Face { get; }
}

public abstract class .....:.....{
    public virtual int Ear()
    {
        return 7;
    }
    public Picasso(string face)
    {
        ..... = face;
    }
    public virtual string Face {
        .....{ .....; }
    }
    string face;
}

public class .....:.....{
    public Clowns() : base("Clowns") { }
}
```

```
public class .....:.....{
    public Acts() : base("Acts") { }
    public override .....{
        return 5;
    }
}

public class .....:..... {
    public override string Face {
        } get { return "Of76"; }
    public static void Main(string[] args) {
        string result = "";
        Nose[] i = new Nose[3];
        i[0] = new Acts();
        i[1] = new Clowns();
        i[2] = new Of76();
        for (int x = 0; x < 3; x++) {
            result += ( ..... + " "
                + ..... ) + "\n";
        }
        MessageBox.Show(result);
    }
}
```

Here's the entry point—this is a complete C# program.



Output

Note: each snippet from the pool can be used more than once!

Acts();	:	i			
Nose();	;	i()			
Of76();	class	i(x)	class	5 class	Acts
Clowns();	abstract	i[x]	7 class	7 class	Nose
Picasso();	interface		7 public class		Of76
	int Ear()				Clowns
Of76 [] i = new Nose[3];	this	get		i.Ear(x)	Picasso
Of76 [3] i;	this.	set		i[x].Ear()	
Nose [] i = new Nose();	face	return		i[x].Ear(
Nose [] i = new Nose[3];	this.face			i[x].Face	

Answers on page 306.



Okay, I think I've got a pretty good handle on objects now!

The idea that you could combine your data and your code into classes and objects was a revolutionary one when it was first introduced—but that's how you've been building all your C# programs so far, so you can think of it as just plain programming.

You're an object oriented programmer.

There's a name for what you've been doing. It's called **object oriented programming**, or OOP. Before languages like C# came along, people didn't use objects and methods when writing their code. They just used functions (which is what they called methods in a non-OOP program) that were all in one place—as if each program were just one big static class that only had static methods. It made it a lot harder to create programs that modeled the problems they were solving. Luckily, you'll never have to write programs without OOP, because it's a core part of C#.

The four principles of object oriented programming

When programmers talk about OOP, they're referring to four important principles. They should seem very familiar to you by now because you've been working with every one of them. You'll recognize the first three principles just from their names: **inheritance**, **abstraction**, and **encapsulation**. The last one's called **polymorphism**. It sounds a little odd, but it turns out that you already know all about it too.

Encapsulation means creating an object that keeps track of its state internally using private fields, and uses public properties and methods to let other classes work with only the part of the internal data that they need to see.

This just means having one class or interface that inherits from another.

* **Inheritance**

* **Encapsulation**

* **Abstraction**

* **Polymorphism**

You're using abstraction when you create a class model that starts with more general—or abstract—classes, and then has more specific classes that inherit from it.

The word "polymorphism" literally means "many forms". Can you think of a time when an object has taken on many forms in your code?

Polymorphism means that one object can take many different forms

Any time you use a mockingbird in place of an animal or aged Vermont cheddar in a recipe that just calls for cheese, you're using **polymorphism**. That's what you're doing any time you upcast or downcast. It's taking an object and using it in a method or a statement that expects something else

Keep your eyes open for polymorphism in the next exercise!

You're about to do a really big exercise—the biggest one you've seen so far—and you'll be using a lot of polymorphism in it. So keep your eyes open for it. Here's a list of four typical ways that you'll use polymorphism. We gave you an example of each of them (you won't see these particular lines in the exercise, though). As soon as you see similar code in the code that you write for the exercise, **check it off the following list**:

- Taking any reference variable that uses one class and setting it equal to an instance of a different class.
- ```
NectarStinger bertha = new NectarStinger();
INectarCollector gatherer = bertha;
```

- Upcasting by using a subclass in a statement or method that expects its base class.
- ```
spot = new Dog();
zooKeeper.FeedAnAnimal(spot);
```

If FeedAnAnimal() expects an Animal object, and Dog inherits from Animal, then you can pass Dog to FeedAnAnimal().

- Creating a reference variable whose type is an interface and pointing it to an object that implements that interface.
- ```
IStingPatrol defender = new StingPatrol();
```

*← This is upcasting, too!*

- Downcasting using the `as` keyword.
- ```
void MaintainTheHive(IWorker worker) {
    if (worker is HiveMaintainer) {
        HiveMaintainer maintainer = worker as HiveMaintainer;
        ...
    }
}
```

← The MaintainTheHive() method takes any IWorker as a parameter. It uses as to point a HiveMaintainer reference to the worker.

You're using polymorphism when you take an instance of one class and use it in a statement or a method that expects a different type, like a parent class or an interface that the class implements.



LONG Exercise

Let's build a house! Create a model of a house using classes to represent the rooms and locations, and an interface for any place that has a door.

1 Start with this class model

Every room or location in your house will be represented by its own object. The interior rooms all inherit from `Room`, and the outside places inherit from `Outside`, which subclass the same base class, `Location`. It has two fields: `Name` is the name of the location ("Kitchen"), and `Exits` is an array of `Location` objects that the current location connects to. So `diningRoom.Name` will be equal to "Dining Room", and `diningRoom.Exits` will be equal to the array { `LivingRoom`, `Kitchen` }.

→ Create a Windows Application project and add `Location`, `Room` and `Outside` classes to it.

2 You'll need the blueprint for the house

This house has three rooms, a front yard, and a garden. There are two doors: the front door connects the living room to the front yard, and the back door connects the kitchen to the back yard.

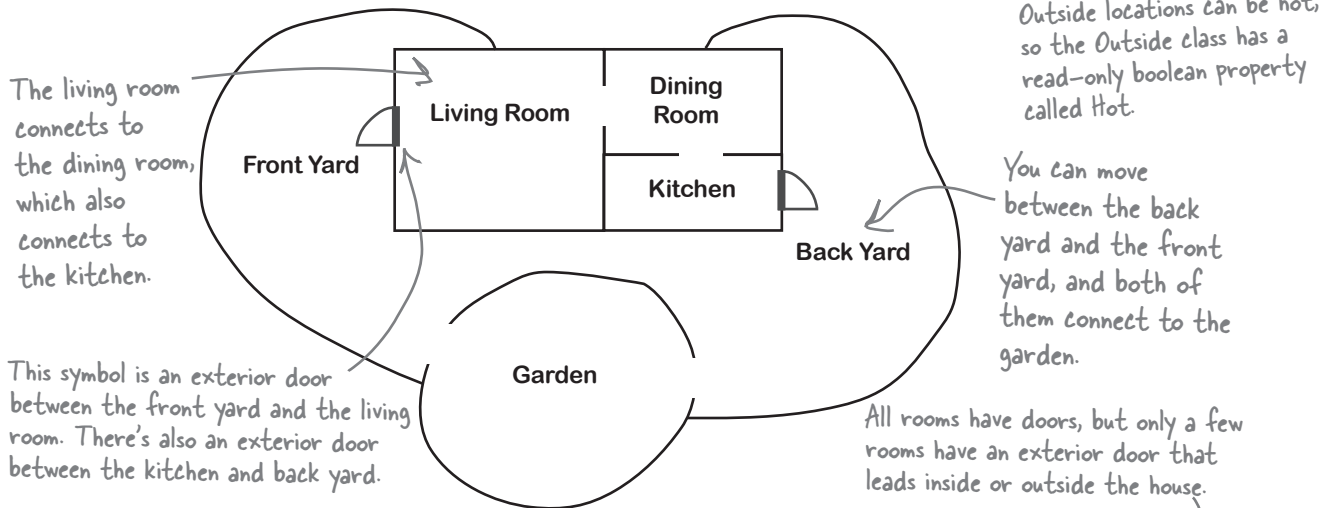

3 Use the `IHasExteriorDoor` interface for rooms with an exterior door

There are two exterior doors in the house, the front door and the back door. Every location that has one (the front yard, back yard, living room, and kitchen) should implement `IHasExteriorDoor`. The `DoorDescription` read-only property contains a description of the door (the front door is "an oak door with a brass knob", the back door is "a screen door"). The `DoorLocation` property contains a reference to the `Location` where the door leads (kitchen).

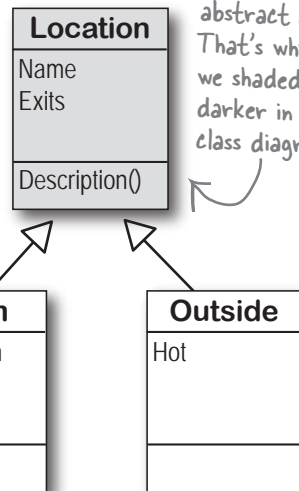

Location is an abstract class. That's why we shaded it darker in the class diagram.

Inside locations each have some kind of a decoration in a read-only property.

Outside locations can be hot, so the `Outside` class has a read-only boolean property called `Hot`.

You can move between the back yard and the front yard, and both of them connect to the garden.

All rooms have doors, but only a few rooms have an exterior door that leads inside or outside the house.

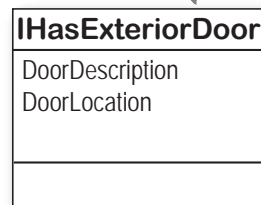

4 Here's the Location class

To get you started, here's the Location class:

```
public abstract class Location {
    public Location(string name) {
        this.name = name;
    }
    public Location[] Exits;
    private string name;
    public string Name {
        get { return name; }
    }
    public virtual string Description {
        get {
            string description = "You're standing in the " + name
                + ". You see exits to the following places: ";
            for (int i = 0; i < Exits.Length; i++) {
                description += " " + Exits[i].Name;
                if (i != Exits.Length - 1)
                    description += ",";
            }
            description += ".";
            return description;
        }
    }
}
```

The constructor sets the name field, which is the read-only Name property's backing field.

Description is a virtual method. You'll need to override it.

The public Exits field is an array of Location references that keeps track of all of the other places that this location connects to.

The Room class will override and extend Description to add the decoration, and Outside will add the temperature.

The Description property returns a string that describes the room, including the name and a list of all of the locations it connects to (which it finds in the Exits[] field). Its subclasses will need to change the description slightly, so they'll override it.

Remember, Location is an abstract class—you can inherit from it and declare reference variables of type Location, but you can't instantiate it.

6 Create the classes

First create the Room and Outside classes based on the class model. Then create two more classes: OutsideWithDoor, which inherits from Outside and implements IHasExteriorDoor, and RoomWithDoor, which subclasses Room and implements IHasExteriorDoor.

Here are the class declarations to give you a leg up:

```
public class OutsideWithDoor : Outside, IHasExteriorDoor
{
    // The DoorLocation property goes here
    // The read-only DoorDescription property goes here
}

public class RoomWithDoor : Room, IHasExteriorDoor
{
    // The DoorLocation property goes here
    // The read-only DoorDescription property goes here
}
```

Get the classes started now—we'll give you more details about them on the next page.

This one's going to be a pretty big exercise... but we promise it's a lot of fun! And you'll definitely know this stuff once you get through it.

—————> We're not done yet—flip the page!



LONG Exercise (CONTINUED)

Now that you've got the class model, you can create the objects for all of the parts of the house, and add a form to explore it.

6 How your house objects work

Here's the architecture for two of your objects, `frontYard` and `diningRoom`. Since each of them has a door, they both need to be instances of a class that implements `IHasExteriorDoor`. The `DoorLocation` property keeps a reference to the location on the other side of the door.

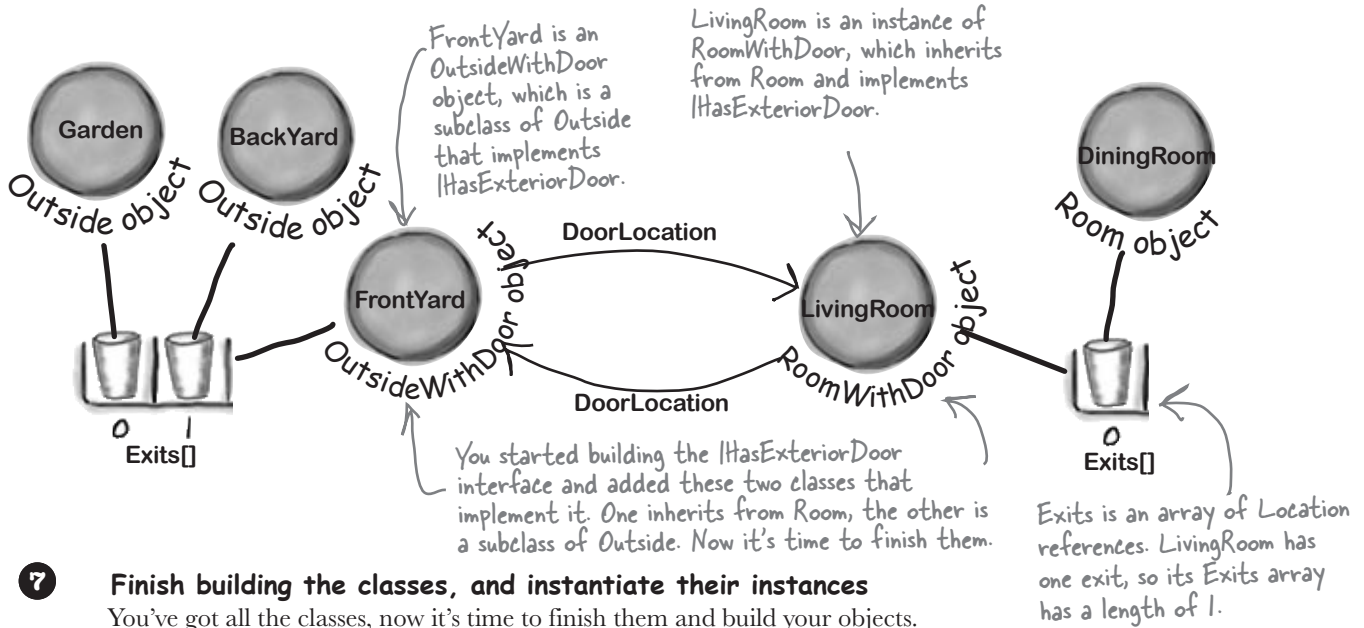

7 Finish building the classes, and instantiate their instances

You've got all the classes, now it's time to finish them and build your objects.

- ★ You'll need to make sure that the constructor for the `Outside` class sets the read-only `Hot` property and overrides the `Description` property to add the text "It's very hot here." if `Hot` is true. It's hot in the back yard but not the front yard or garden.
- ★ The constructor for `Room` needs to set the `Decoration`, and should override the `Description` property to add, "You see (*the decoration*) here." The living room has an antique carpet, the dining room has a crystal chandelier, and the kitchen has stainless steel appliances and a screen door that leads to the back yard.
- ★ Your form needs to create each of the objects and keep a reference to each one. So add a method to the form called `CreateObjects()` and call it from the form's constructor.
- ★ Instantiate each of the objects for the six locations in the house. Here's one of those lines:

```
RoomWithDoor livingRoom = new RoomWithDoor("Living Room",
    "an antique carpet", "an oak door with a brass knob");
```

- ★ Your `CreateObjects()` method needs to populate the `Exits[]` field in each object:

```
frontYard.Exits = new Location[] { backYard, garden };
```

Exits is an array of `Location` references, so this line creates one and that has two references in it.

Every location will have its own field in the form class.

These are curly brackets. Anything else will cause an error.

8 Build a form to explore the house

Build a simple form to let you explore the house. It'll have a big multiline textbox called description to show the description of the current room. A ComboBox called exits lists all of the exits in the current room. It's got two buttons: goHere moves to the room selected in the ComboBox, and goThroughTheDoor is only visible when there's an exterior door.

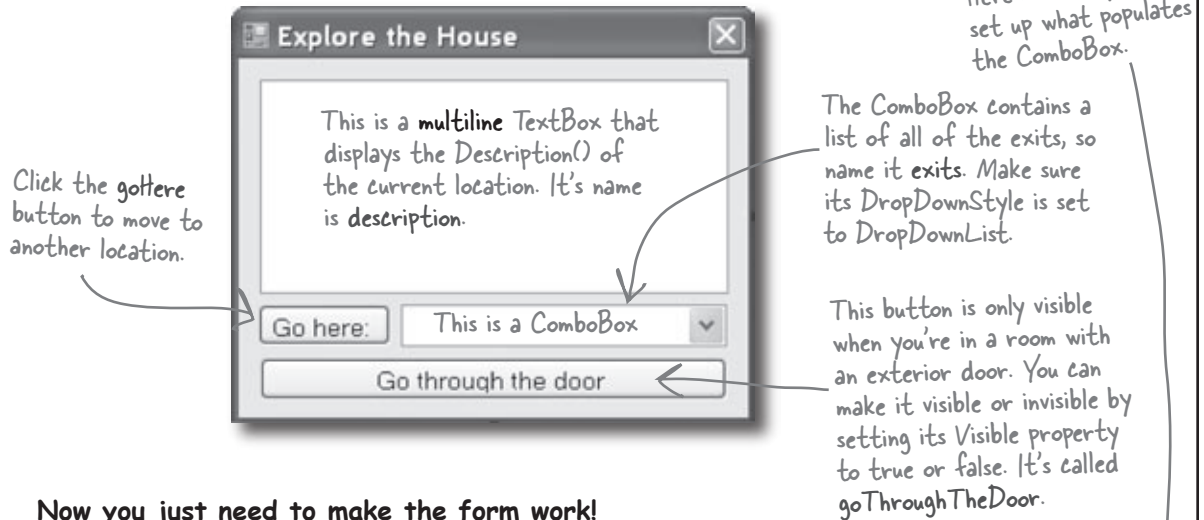

9 Now you just need to make the form work!

You've got all the pieces, now you just need to put them together.

- ★ You'll need a field in your form called `currentLocation` to keep track of your current location.
- ★ Add a `MoveToANewLocation()` method that has a `Location` as its parameter. This method should first set `currentLocation` to the new location. Then it'll clear the combo box using its `Items.Clear()` method, and then add the name of each location in the `Exits[]` array using the combo box's `Items.Add()` method. Finally, reset the combo box so it displays the first item in the list by setting its `SelectedIndex` property to zero.
- ★ Set the textbox so that it has the description of the current location.
- ★ Use the `is` keyword to check if the current location has a door. If it does, make the "Go through the door" button visible using its `Visible` property. If not, make it invisible.
- ★ If the "Go here:" button is clicked, move to the location selected in the combo box.
- ★ If the "Go through the door" button is clicked, move to the location that the door connects to.

Hint: When you choose an item in the combo box, its selected index in the combo box will be the same as the index of the corresponding location in the `Exits[]` array.

Another hint: Your form's `currentLocation` field is a `Location` reference. So even though it's pointing to an object that implements `IHasExteriorDoor`, you can't just type `currentLocation.DoorLocation` because `DoorLocation` isn't a field in `Location`. You'll need to downcast if you want to get the door location out of the object.



LONG Exercise SOLUTION

Here's the code to model the house. We used classes to represent the rooms and locations, and an interface for any place that has a door.

```
public interface IHasExteriorDoor {
    string DoorDescription { get; }
    Location DoorLocation { get; set; }
}
```

Here's the `IHasExteriorDoor` interface.

```
public class Room : Location {
    private string decoration;

    public Room(string name, string decoration)
        : base(name) {
        this.decoration = decoration;
    }
}
```

The `Room` class inherits from `Location` and adds a backing field for the read-only `Decoration` property. Its constructor sets the field.

```
public override string Description {
    get {
        return base.Description + " You see " + decoration + ".";
    }
}
```

```
public class RoomWithDoor : Room, IHasExteriorDoor {
    public RoomWithDoor(string name, string decoration, string doorDescription)
        : base(name, decoration)
    {
        this.doorDescription = doorDescription;
    }
}
```

```
private string doorDescription;
public string DoorDescription {
    get { return doorDescription; }
}
```

```
private Location doorLocation;
public Location DoorLocation {
    get { return doorLocation; }
    set { doorLocation = value; }
}
```

```
}
```

The `RoomWithDoor` class inherits from `Room` and implements `IHasExteriorDoor`. It does everything that the room does, but it adds a description of the exterior door to the constructor. It also adds `DoorLocation`, a reference to the location that the door leads to. `DoorDescription` and `DoorLocation` are required by `IHasExteriorDoor`.

```

public class Outside : Location {
    private bool hot;
    public bool Hot { get { return hot; } }

    public Outside(string name, bool hot)
        : base(name)
    {
        this.hot = hot;
    }

    public override string Description {
        get {
            string NewDescription = base.Description;
            if (hot)
                NewDescription += " It's very hot.";
            return NewDescription;
        }
    }
}

```

Outside is a lot like Room—it inherits from Location, and adds a backing field for the Hot property, which is used in the Description() method extended from the base class.

```

public class OutsideWithDoor : Outside, IHasExteriorDoor {
    public OutsideWithDoor(string name, bool hot, string doorDescription)
        : base(name, hot)
    {
        this.doorDescription = doorDescription;
    }

    private string doorDescription;
    public string DoorDescription {
        get { return doorDescription; }
    }
}

```

OutsideWithDoor inherits from Outside and implements IHasExteriorDoor, and it looks a lot like RoomWithDoor.

```

private Location doorLocation;
public Location DoorLocation {
    get { return doorLocation; }
    set { doorLocation = value; }
}

```

The base class's Description property fills in whether or not the location is hot. And that relies on the original Location class's Description property to add the main description and exits.

```

public override string Description {
    get {
        return base.Description + " You see " + doorDescription + ".";
    }
}
}

```

→ We're not done yet—flip the page!



LONG EXERCISE SOLUTION (CONTINUED)

Here's the code for the form. It's all in the Form1.cs, inside the Form1 declaration.

```
public partial class Form1 : Form
{
    Location currentLocation;

    RoomWithDoor livingRoom;
    Room diningRoom;
    RoomWithDoor kitchen;

    OutsideWithDoor frontYard;
    OutsideWithDoor backYard;
    Outside garden;

    public Form1() {
        InitializeComponent();
        CreateObjects();
        MoveToANewLocation(livingRoom);
    }

    private void CreateObjects() {
        livingRoom = new RoomWithDoor("Living Room", "an antique carpet",
            "an oak door with a brass knob");
        diningRoom = new Room("Dining Room", "a crystal chandelier");
        kitchen = new RoomWithDoor("Kitchen", "stainless steel appliances", "a screen door");

        frontYard = new OutsideWithDoor("Front Yard", false, "an oak door with a brass knob");
        backYard = new OutsideWithDoor("Back Yard", true, "a screen door");
        garden = new Outside("Garden", false);

        diningRoom.Exits = new Location[] { livingRoom, kitchen };
        livingRoom.Exits = new Location[] { diningRoom };
        kitchen.Exits = new Location[] { diningRoom };
        frontYard.Exits = new Location[] { backYard, garden };
        backYard.Exits = new Location[] { frontYard, garden };
        garden.Exits = new Location[] { backYard, frontYard };

        livingRoom.DoorLocation = frontYard;
        frontYard.DoorLocation = livingRoom;

        kitchen.DoorLocation = backYard;
        backYard.DoorLocation = kitchen;
    }
}
```

This is how the form keeps track of which room is being displayed.

The form uses these reference variables to keep track of each of the rooms in the house.

The form's constructor creates the objects and then uses the MoveToANewLocation method.

When the form creates the objects, first it needs to instantiate the classes and pass the right information to each one's constructor.

Here's where we pass the door description to the OutsideWithDoor constructors.

Here's where the Exits[] array for each instance is populated. We need to wait to do this until after all the instances are created, because otherwise we wouldn't have anything to put into each array!

For the IHasExteriorDoor objects, we need to set their door locations.

```
private void MoveToANewLocation(Location newLocation) {
    currentLocation = newLocation;

    exits.Items.Clear();
    for (int i = 0; i < currentLocation.Exits.Length; i++)
        exits.Items.Add(currentLocation.Exits[i].Name);
    exits.SelectedIndex = 0;

    description.Text = currentLocation.Description;

    if (currentLocation is IHasExteriorDoor)
        goThroughTheDoor.Visible = true;
    else
        goThroughTheDoor.Visible = false;
}

private void goHere_Click(object sender, EventArgs e) {
    MoveToANewLocation(currentLocation.Exits[exits.SelectedIndex]);
}

private void goThroughTheDoor_Click(object sender, EventArgs e) {
    IHasExteriorDoor hasDoor = currentLocation as IHasExteriorDoor;
    MoveToANewLocation(hasDoor.DoorLocation);
}
}
```

← The MoveToANewLocation() method displays a new location in the form.

First we need to clear the combo box, then we can add each of the locations' names to it. Finally, we set its selected index (or which line is highlighted) to zero so it shows the first item in the list. Don't forget to set the ComboBox's DropDownStyle property to "DropDownList"—that way the user won't be able to type anything into the combo box.

↑ This makes the "Go through the door" button invisible if the current location doesn't implement IHasExteriorDoor.

← When the user clicks the "Go here:" button, it moves to the location selected in the combo box.

↑ We need to use the as keyword in order to downcast currentLocation to an IHasExteriorDoor so we can get access to the DoorLocation field.



But we're not done yet!

It's fine to create a model of a house, but wouldn't it be cool to turn it into a game? Let's do it! You'll play Hide and Seek against the computer. We'll need to add an Opponent class and have him hide in a room. And we'll need to make the house a lot bigger. Oh, and he'll need someplace to hide! We'll add a new interface so that some rooms can have a hiding place. Finally, we'll update the form to let you check the hiding places, and keep track of how many moves you've made trying to find your opponent. Sound fun? Definitely!

→ Let's get started!



Exercise

Time for hide and seek! Build on your original house program to add more rooms, hiding places, and an opponent who hides from you.

Create a new project, and use the IDE's "Add Existing Item" feature to add the classes from the first part of the exercise.

1 Add an IHidingPlace interface

We don't need to do anything fancy here. Any Location subclass that implements IHidingPlace has a place for the opponent to hide. It just needs a string to store the name of the hiding place ("in the closet", "under the bed", etc.)

- ★ Give it a get accessor, but no set accessor—we'll set this in the constructor, since once a room has a hiding place we won't ever need to change it.

2 Add classes that implement IHidingPlace

You'll need two more classes: OutsideWithHidingPlace (which inherits from Outside) and RoomWithHidingPlace (which inherits from Room). Also, let's make any room with a door have a hiding place, so it'll have to inherit from RoomWithHidingPlace instead of Room.

3 Add a class for your opponent

The Opponent object will find a random hiding place in the house, and it's your job to find him.

- ★ He'll need a private Location field (`myLocation`) so he can keep track of where he is, and a private Random field (`random`) to use when he moves to a random hiding place.
- ★ The constructor takes the starting location and sets `myLocation` to it, and sets `random` to a new instance of Random. He starts in the front yard (that'll be passed in by the form), and moves from hiding place to hiding place randomly. He moves 10 times when the game starts. When he encounters an exterior door, he flips a coin to figure out whether or not to go through it.
- ★ Add a `Move()` method that moves the opponent from his current location to a new location. First, if he's in a room with a door, then he flips a coin to decide whether or not to go through the door, so if `random.Next(2)` is equal to 1, he goes through it. Then he chooses one of the exits from his current location at random and goes through it. If it doesn't have a hiding place, then he'll do it again—he'll choose a random exit from his current location and go there, and he'll keep doing it over and over until he finds a place to hide.
- ★ Add a `Check()` method that takes a location as a parameter and returns true if he's hiding in that location, or false otherwise.

4 Add more rooms to the house

Update your `CreateObjects()` method to add more rooms:

- ★ Add **stairs** with a wooden bannister that connect the living room to the **upstairs hallway**, which has a picture of a dog and a closet to hide in.
- ★ The upstairs hallway connects to three rooms: a **master bedroom** with a large bed, a **second bedroom** with a small bed, and a **bathroom** with a sink and a toilet. Someone could hide under the bed in either bedroom or in the shower.
- ★ The front yard and back yard both connect to the **driveway**, where someone could hide in the garage. Also, someone could hide in the shed in the **garden**.

So every room with an exterior door will also have a hiding place.

5 Okay, time to update the form

You'll need to add a few buttons to the form. And we'll get a little more intricate with making them visible or invisible, depending on the state of the game.

The middle button's called check. You don't need to set its Text property.

You use the top two buttons and the combo box exactly the same way as before, except that they're only visible while the game is running.

When the game first starts, the hide button is the only one displayed. When you click it, the form counts to 10 in the text box, and calls the opponent's Move() method 10 times. Then it makes this button invisible.

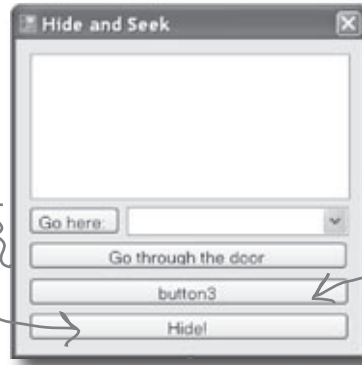

This is the button you'll use to check the room's hiding place. It's only visible if you're in a room that has a place to hide. When it's shown, the Text property is changed from "button3" to "Check" followed by the name of the hiding place—so for a room with a hiding place under the bed, the button will say, "Check under the bed".

6 Make the buttons work

There are two new buttons to add to the form.

Flip back to Chapter 2 for a refresher on DoEvents() and Sleep()—they'll come in handy.

- ★ The middle button checks the hiding place in the current room and is only visible when you're in a room with a place to hide using the opponent's Check () method. If you found him, then it resets the game.
- ★ The bottom button is how you start the game. It counts to 10 by showing "1...", waiting 200 milliseconds, then showing "2...", then "3...", etc. in the text box. After each number, it tells the opponent to move by calling his Move () method. Then it shows, "Ready or not, here I come!" for half a second, and then the game starts.

7 Add a method to redraw the form, and another one to reset the game

Add a RedrawForm () method that puts the right text in the description textbox, makes the buttons visible or invisible, and puts the correct label on the middle button. Then add a ResetGame () method that's run when you find the opponent. It resets the opponent object so that he starts in the front yard again—he'll hide when the user clicks the "Hide!" button. It should leave the form with nothing but the text box and "Hide!" button visible. The text box should say where you found the opponent, and how many moves it took.

8 Keep track of how many moves the player made

Make sure the text box displays the number of times the player checked a hiding place or moved between rooms. When you find the opponent, he should pop up a message box that says, "You found me in X moves!"

9 Make it look right when you start the program

When you first start the program, all you should see is an empty text box and the "Hide!" button. When you click the button, the fun begins!

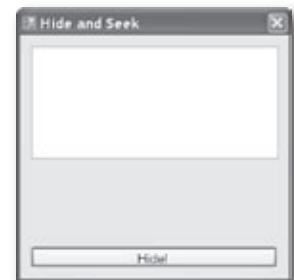



Exercise Solution

Build on your original house program to add more rooms, hiding places, and an opponent who hides from you.

Here's the new IHidingPlace interface. It just has one string field with a get accessor that returns the name of the hiding place.

```
public interface IHidingPlace {
    string HidingPlaceName { get; }
}
```

```
public class RoomWithHidingPlace : Room, IHidingPlace {
    public RoomWithHidingPlace(string name, string decoration, string hidingPlaceName)
        : base(name, decoration)
    {
        this.hidingPlaceName = hidingPlaceName;
    }
    private string hidingPlaceName;
    public string HidingPlaceName {
        get { return hidingPlaceName; }
    }
    public override string Description {
        get {
            return base.Description + " Someone could hide " + hidingPlaceName + ".";
        }
    }
}
```

The RoomWithHidingPlace class inherits from Room and implements IHidingPlace by adding the HidingPlaceName property. The constructor sets its backing field.

```
public class RoomWithDoor : RoomWithHidingPlace, IHasExteriorDoor {
    public RoomWithDoor(string name, string decoration,
        string hidingPlaceName, string doorDescription)
        : base(name, decoration, hidingPlaceName)
    {
        this.doorDescription = doorDescription;
    }
    private string doorDescription;
    public string DoorDescription {
        get { return doorDescription; }
    }
    private Location doorLocation;
    public Location DoorLocation {
        get { return doorLocation; }
        set { doorLocation = value; }
    }
}
```

Since we decided every room with a door also needed a hiding place, we made RoomWithDoor inherit from RoomWithHidingPlace. The only change to it is that its constructor takes a hiding place name and sends it on to the RoomWithHidingPlace constructor.

```

public class OutsideWithHidingPlace : Outside, IHidingPlace {
    public OutsideWithHidingPlace(string name, bool hot, string hidingPlaceName)
        : base(name, hot)
    { this.hidingPlaceName = hidingPlaceName; }

    private string hidingPlaceName;
    public string HidingPlaceName {
        get { return hidingPlaceName; }
    }

    public override string Description {
        get {
            return base.Description + " Someone could hide " + hidingPlaceName + ".";
        }
    }
}

public class Opponent {
    private Random random;
    private Location myLocation;
    public Opponent(Location startingLocation) {
        myLocation = startingLocation;
        random = new Random();
    }

    public void Move() {
        if (myLocation is IHasExteriorDoor) {
            IHasExteriorDoor LocationWithDoor =
                myLocation as IHasExteriorDoor;

            if (random.Next(2) == 1)
                myLocation = LocationWithDoor.DoorLocation;
        }

        bool hidden = false;
        while (!hidden) {
            int rand = random.Next(myLocation.Exits.Length);
            myLocation = myLocation.Exits[rand];
            if (myLocation is IHidingPlace)
                hidden = true;
        }
    }

    public bool Check(Location locationToCheck) {
        if (locationToCheck != myLocation)
            return false;
        else
            return true;
    }
}

```

The OutsideWithHidingPlace class inherits from Outside and implements IHidingPlace just like RoomWithHidingPlace does.

The Opponent class constructor takes a starting location. It creates a new instance of Random, which it uses to move randomly between rooms.

The Move() method first checks if the current room has a door using the is keyword—if so, it has a 50% chance of going through it. Then it moves to a random location, and keeps moving until it finds a hiding place.

The guts of the Move() method is this while loop. It keeps looping until the variable hidden is true—and it sets it to true when it finds a room with a hiding place.

The Check() method just checks the opponent's location against the location that was passed to it using a Location reference. If they point to the same object, then he's been found!

—————▶ We're not done yet—flip the page!



Exercise Solution (CONTINUED)

Here are all the fields in the Form1 class. It uses them to keep track of the locations, the opponent and the number of moves the player has made.

The Form1 constructor creates the objects, sets up the opponent, and then resets the game. We added a boolean parameter to ResetGame() so that it only displays its message when you win, not when you first start up the program.

```

public Form1() {
    InitializeComponent();
    CreateObjects();
    opponent = new Opponent(frontYard);
    ResetGame(false);
}

private void MoveToANewLocation(Location newLocation) {
    Moves++;
    currentLocation = newLocation;
    RedrawForm();
}

private void RedrawForm() {
    exits.Items.Clear();
    for (int i = 0; i < currentLocation.Exits.Length; i++)
        exits.Items.Add(currentLocation.Exits[i].Name);
    exits.SelectedIndex = 0;
    description.Text = currentLocation.Description + "\r\n(move #" + Moves + ")";
    if (currentLocation is IHidingPlace) {
        IHidingPlace hidingPlace = currentLocation as IHidingPlace;
        check.Text = "Check " + hidingPlace.HidingPlaceName;
        check.Visible = true;
    }
    else
        check.Visible = false;
    if (currentLocation is IHasExteriorDoor)
        goThroughTheDoor.Visible = true;
    else
        goThroughTheDoor.Visible = false;
}
    
```

```

int Moves;

Location currentLocation;

RoomWithDoor livingRoom;
RoomWithHidingPlace diningRoom;
RoomWithDoor kitchen;
Room stairs;
RoomWithHidingPlace hallway;
RoomWithHidingPlace bathroom;
RoomWithHidingPlace masterBedroom;
RoomWithHidingPlace secondBedroom;

OutsideWithDoor frontYard;
OutsideWithDoor backYard;
OutsideWithHidingPlace garden;
OutsideWithHidingPlace driveway;

Opponent opponent;
    
```

The MoveToANewLocation() method sets the new location and then redraws the form.

We need the hiding place name, but we've only got the CurrentLocation object which doesn't have a HidingPlaceName property, so we can use as to downcast the reference to an IHidingPlace variable.

RedrawForm() populates the combo box list, sets the text (adding the number of moves), and then makes the buttons visible or invisible depending on whether or not there's a door or the room has a hiding place.

Wow—you could add an entire wing onto the house just by adding a couple of lines! That's why well-encapsulated classes and objects are really useful.

```
private void CreateObjects() {
    livingRoom = new RoomWithDoor("Living Room", "an antique carpet",
        "inside the closet", "an oak door with a brass handle");
    diningRoom = new RoomWithHidingPlace("Dining Room", "a crystal chandelier",
        "in the tall armoire");
    kitchen = new RoomWithDoor("Kitchen", "stainless steel appliances",
        "in the cabinet", "a screen door");
    stairs = new Room("Stairs", "a wooden bannister");
    hallway = new RoomWithHidingPlace("Upstairs Hallway", "a picture of a dog",
        "in the closet");
    bathroom = new RoomWithHidingPlace("Bathroom", "a sink and a toilet",
        "in the shower");
    masterBedroom = new RoomWithHidingPlace("Master Bedroom", "a large bed",
        "under the bed");
    secondBedroom = new RoomWithHidingPlace("Second Bedroom", "a small bed",
        "under the bed");

    frontYard = new OutsideWithDoor("Front Yard", false, "a heavy-looking oak door");
    backYard = new OutsideWithDoor("Back Yard", true, "a screen door");
    garden = new OutsideWithHidingPlace("Garden", false, "inside the shed");
    driveway = new OutsideWithHidingPlace("Driveway", true, "in the garage");

    diningRoom.Exits = new Location[] { livingRoom, kitchen };
    livingRoom.Exits = new Location[] { diningRoom, stairs };
    kitchen.Exits = new Location[] { diningRoom };
    stairs.Exits = new Location[] { livingRoom, hallway };
    hallway.Exits = new Location[] { stairs, bathroom, masterBedroom, secondBedroom };
    bathroom.Exits = new Location[] { hallway };
    masterBedroom.Exits = new Location[] { hallway };
    secondBedroom.Exits = new Location[] { hallway };
    frontYard.Exits = new Location[] { backYard, garden, driveway };
    backYard.Exits = new Location[] { frontYard, garden, driveway };
    garden.Exits = new Location[] { backYard, frontYard };
    driveway.Exits = new Location[] { backYard, frontYard };

    livingRoom.DoorLocation = frontYard;
    frontYard.DoorLocation = livingRoom;

    kitchen.DoorLocation = backYard;
    backYard.DoorLocation = kitchen;
}
```

The new CreateObjects() method creates all the objects to build the house. It's a lot like the old one, but it has a whole lot more places to go.

—————→ We're still not done—flip the page!



Exercise Solution (CONTINUED)

Here's the rest of the code for the form. The `goHere` and `goThroughTheDoor` button event handlers are identical to the ones in the first part of this exercise, so flip back a few pages to see them.

```
private void ResetGame(bool displayMessage) {
    if (displayMessage) {
        MessageBox.Show("You found me in " + Moves + " moves!");
        IHidingPlace foundLocation = currentLocation as IHidingPlace;
        description.Text = "You found your opponent in " + Moves
            + " moves! He was hiding " + foundLocation.HidingPlaceName + ".";
    }
    Moves = 0;
    hide.Visible = true;
    goHere.Visible = false;
    check.Visible = false;
    goThroughTheDoor.Visible = false;
    exits.Visible = false;
}
```

The `ResetGame()` method resets the game. It displays the final message, then makes all the buttons except the "Hide!" one invisible.

We want to display the name of the hiding place, but `CurrentLocation` is a `Location` reference, so it doesn't give us access to the `HidingPlaceName` field. Luckily, we can use the `as` keyword to downcast it to an `IHidingPlace` reference that points to the same object.

```
private void check_Click(object sender, EventArgs e) {
    Moves++;
    if (opponent.Check(currentLocation))
        ResetGame(true);
    else
        RedrawForm();
}
```

When you click the `check` button, it checks whether or not the opponent is hiding in the current room. If he is, it resets the game. If not, it redraws the form (to update the number of moves).

```
private void hide_Click(object sender, EventArgs e) {
    hide.Visible = false;

    for (int i = 1; i <= 10; i++) {
        opponent.Move();
        description.Text = i + "... ";
        Application.DoEvents();
        System.Threading.Thread.Sleep(200);
    }
```

Remember `DoEvents()` from `FlashyThing` in Chapter 2? Without it, the textbox doesn't refresh itself and the program looks frozen.

```
description.Text = "Ready or not, here I come!";
Application.DoEvents();
System.Threading.Thread.Sleep(500);

goHere.Visible = true;
exits.Visible = true;
MoveToANewLocation(livingRoom);
}
```

The `hide` button is the one that starts the game. The first thing it does is make itself invisible. Then it counts to 10 and tells the opponent to move. Finally, it makes the first button and the combo box visible, and then starts off the player in the living room. The `MoveToANewLocation()` method calls `RedrawForm()`.



Objectcross

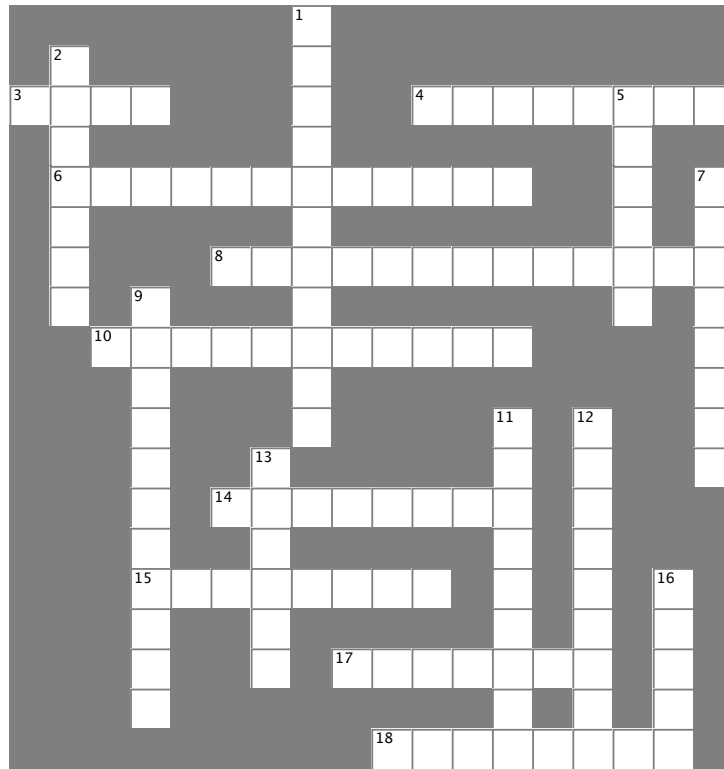

Across

3. What an abstract method doesn't have
4. C# doesn't allow _____ inheritance
6. When you pass a subclass to a method that expects its base class, you're using this OOP principle
8. The OOP principle where you hide private data and only expose those methods and fields that other classes need access to
10. One of the four principles of OOP that you implement using the colon operator
14. Every method in an interface is automatically _____
15. Your class that implements an interface that _____ from another interface, then you need to implement all of its members too
17. An access modifier that's not valid for anything inside an interface
18. Object _____ Programming means creating programs that combine your data and code together into classes and objects

Down

1. When you move common methods from specific classes to more a general class that they all inherit from, you're using this OOP principle
2. If a class that implements an interface doesn't implement all of its methods, getters and setters, then the project won't _____
5. Everything in an interface is automatically _____
7. An abstract class can include both abstract and _____ methods
9. You can't _____ an abstract class
11. A class that implements this must include all of the methods, getters and setters that it defines
12. What you do with an interface
13. The `is` keyword returns true if an _____ implements an interface
16. An interface can't technically include a _____, but it can define getters and setters that look just like one from the outside



Pool Puzzle Solution from page 287

Your job is to take code snippets from the pool and place them into the blank lines in the code and output. You may use the same snippet more than once, and you won't need to use all the snippets. Your goal is to make a set of classes that will compile and run and produce the output listed.

Here's where the Acts class calls the constructor in Picasso, which it inherits from. It passes "Acts" into the constructor, which gets stored in the face property.

```
public interface Nose {
    int Ear();
    string Face { get; }
}
```

```
public abstract class Picasso : Nose {
    public virtual int Ear()
    {
        return 7;
    }
    public Picasso(string face)
    {
        this.face = face;
    }
    public virtual string Face {
        get { return face; }
    }
    string face;
}
```

```
public class Clowns : Picasso {
    public Clowns() : base("Clowns") { }
}
```

```
public class Acts : Picasso {
    public Acts() : base("Acts") { }
    public override int Ear() {
        return 5;
    }
}
```

```
public class Of76 : Clowns {
    public override string Face {
        get { return "Of76"; }
    }
    public static void Main(string[] args) {
        string result = "";
        Nose[] i = new Nose[3];
        i[0] = new Acts();
        i[1] = new Clowns();
        i[2] = new Of76();
        for (int x = 0; x < 3; x++) {
            result += ( i[x].Ear() + " "
                + i[x].Face ) + "\n";
        }
        MessageBox.Show(result);
    }
}
```

Properties can appear anywhere in the class! It's easier to read your code if they're at the top, but it's perfectly valid to have the face property at the bottom of the Picasso class.

Face is a get accessor that returns the value of the face property. Both of them are defined in Picasso and inherited into the subclasses.

8 enums and collections

Storing lots of data

Finally, a way to organize
my boyfriends!



When it rains, it pours.

In the real world, you don't get to handle your data in tiny little bits and pieces. No, your data's going to come at you in **loads, piles, and bunches**. You'll need some pretty powerful tools to organize all of it, and that's where **collections** come in. They let you **store, sort, and manage** all the data that your programs need to pore through. That way you can think about writing programs to work with your data, and let the collections worry about keeping track of it for you.

Strings don't always work for storing categories of data

Suppose you have several worker bees, all represented by `Worker` classes. How would you write a constructor that took a job as a parameter? If you use a string for the job name, you might end up with code that looks like this:

Our bee management software kept track of each worker's job using a string like "Sting Patrol" or "Nectar Collector".

Our code would allow these values to be passed in a constructor even though the program only supports Sting Patrol, Nectar Collector and other jobs that a bee does.

```
Worker buzz = new Worker("Attorney General");  
Worker clover = new Worker("Dog Walker");  
Worker gladys = new Worker("Newscaster");
```

This code compiles, no problem. But these jobs don't make any sense for a bee. The `Worker` class really shouldn't allow these types as valid data.

You could probably add code to the `Worker` constructor to check each string and make sure it's a valid bee job. Although, if you add new jobs that bees can do, you've got to change this code and recompile the `Worker` class. But that's a pretty short-sighted solution. What if you have other classes that need to check for the types of worker bees they can be? Now you've got to duplicate code, and that's a bad path to go down.

What we need is a way to say, "Hey, there are only certain values that are allowed here." We need to **enumerate** the values that are okay to use.



Enums let you enumerate a set of valid values

An enum is a data type that only allows certain values for that piece of data. So we could define an enum called `Jobs`, and define the allowed jobs:

```
public enum Job {
    NectarCollector,
    StingPatrol,
    HiveMaintenance,
    BabyBeeTutoring,
    EggCare,
    HoneyManufacturing,
}
```

The last enumerator doesn't have to end with a comma, but using one makes it easier to rearrange them using cut and paste.

This is the name of the enum.

Each of these is a valid job. Any can be used as a `Jobs` value.

Separate each value with a comma, and end the whole thing with a curly brace.

The stuff inside the brackets is called the **enumerator list**, and each one of them is an **enumerator**. The whole thing together is called an **enumeration**.

But most people just call them **enums**.

Now, you can reference these with types like this:

```
Worker nanny = new Worker(Job.EggCare);
```

This is the name of the enum.

Finally, the value you want from the enum.

We've changed the `Worker` constructor to accept `Worker.Jobs` as its parameter type.

Any other values aren't allowed. You can't just make up a new value for the enum. If you do, the program won't compile.

```
private void button1_Click(object sender EventArgs e)
{
    Worker buzz = new Worker(Jobs.AttorneyGeneral);
}
```

X 'Jobs' does not contain a definition for 'AttorneyGeneral'

Here's the error you get from the compiler.

Enums let you represent numbers with names

Sometimes it's easier to work with numbers if you have names for them. You can assign numbers to the values in an enum and use the names to refer to them. That way, you don't have bunch of unexplained numbers floating around in your code. Here's an enum to keep track of the scores for tricks at a dog competition. This enum is **inside the DogCompetition class** (a lot of the time, your enum won't be inside any class!), so if you want to use it outside the class you'll need to call it `DogCompetition.TrickScores`.

You can cast an int to an enum, and you can cast an enum back to an int.

```

class DogCompetition {
    public enum TrickScore {
        Sit = 7,
        Beg = 25,
        RollOver = 50,
        Fetch = 10,
        ComeHere = 5,
        Speak = 30,
    }
    ...
    // code later in the class
    int value = (int)TrickScore.Fetch * 3;
    MessageBox.Show(value.ToString());
    TrickScore score = (TrickScore)value;
    MessageBox.Show(score.ToString());
}
    
```

These don't have to be in any particular order, and you can give multiple names to the same number.

This is the DogCompetition.TrickScores enum.

Supply a name, then "=", then the number that name stands in for.

The (int) cast tells the compiler to turn this into the number it represents. So since TrickScore.Speak has an index of 20, (int)TrickScore.Speak turns it into the int value 20.

Since Fetch has an index of 10, this statement sets value to 30.

You can cast an int back to a TrickScore. Since value is equal to 30, score gets set to TrickScore.Speak. So when you call score.ToString(), it returns "Speak".

You can cast the enum as a number and do calculations with it, or you can use the `ToString()` method to treat the name as a string. If you don't assign any number to a name, the items in the list will be given index numbers by default. The first item will be assigned a 0 value, the second a 1, etc.

But what happens if you want to use really big numbers for one of the enumerators? The default type for the numbers in an enum is `int`, so you'll need to specify the type you need using the `:` operator, like this:

```

public enum TrickScore : long {
    Sit = 7,
    Beg = 2500000000025
}
    
```

This tells the compiler to treat values in the TrickScores enum as longs, not ints.

You can put an enum inside a class like this, or it can exist on its own outside of a class.

If you tried to compile this code without specifying long as the type, you'd get this message:

Cannot implicitly convert type 'long' to 'int'.



Exercise

Use what you've learned about enums to build a class that holds a playing card.

1 Create a new project and add a Card class

You'll need two public fields: Suit (which will either be Spades, Clubs, Diamonds, or Hearts) and Value (Ace, Two, Three ... Ten, Jack, Queen, King). And you'll need a read-only property, Name ("Ace of Spades", "Five of Diamonds").

Card
Suit
Value
Name

2 Use two enums to define the suits and values.

Make sure that `(int) Card.Suits.Spades` is equal to 0, followed by Clubs (equal to 1), Diamonds (2), and Hearts (3). Make the values equal to their face values: `(int) Card.Values.Ace` should equal 1, Two should be 2, Three should be 3, etc. Jack should equal 11, Queen should be 12, and King should be 13.

3 Add a property for the name of the card

Name should be a read-only property. The get accessor should return a string that describes the card. This code will run in a form that calls the Name property from the card class and displays it:

```
Card card = new Card(Card.Suits.Spades, Card.Values.Ace);
string cardName = card.Name;
```

The value of `cardName` should be "Ace of Spades".

To make this work, your Card class will need a constructor that takes two parameters.

4 Add a form button that pops up the name of a random card

You can get your program to create a card with a random suit and value by casting a random number between 0 and 3 as `Cards.Suits` and another random number between 1 and 13 as `Cards.Values`. To do this, you can take advantage of a feature of the built-in `Random` class that gives it three different ways to call its `Next()` method:

```
Random random = new Random();
int numberBetween0and3 = random.Next(4);
int numberBetween1and13 = random.Next(1, 14);
int anyRandomInteger = random.Next();
```

This tells `Random` to return a value at least 1 but under 14.

When you've got more than one way to call a method, it's called overloading. More on that later...



there are no Dumb Questions

Q: Hold on a second. When I was typing in that code, I noticed that an IntelliSense window popped up that said something about "3 of 3" when I used that `Random.Next()` constructor. What was that about?

A: What you saw was a method that was **overloaded**. When a class has a method that you can call more than one way, it's called overloading. When you're using a class with an overloaded method, the IDE lets you know all of the options that you have. In this case, the `Random` class has three possible `Next()` methods. As soon

as you type "`random.Next("` into the code window, the IDE pops up its IntelliSense box that shows the parameters for the different overloaded methods. The up and down arrows next to the "3 of 3" let you scroll between them. That's really useful when you're dealing with a method that has dozens of overloaded definitions. So when you're doing it, make sure you choose the right overloaded `Next()` method! But don't worry too much now—we'll talk a lot about overloading later on in the chapter.

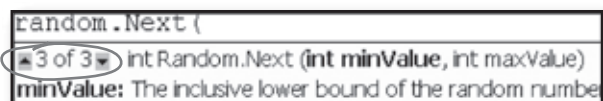



Exercise Solution

A deck of cards is a great example of where limiting values is important. Nobody wants to turn over their cards and be faced with a Joker of Clubs, or a 13 of Hearts. Here's how we wrote the Card class.

```
public class Card {
    public enum Suits {
        Spades,
        Clubs,
        Diamonds,
        Hearts
    }

    public enum Values {
        Ace = 1,
        Two = 2,
        Three = 3,
        Four = 4,
        Five = 5,
        Six = 6,
        Seven = 7,
        Eight = 8,
        Nine = 9,
        Ten = 10,
        Jack = 11,
        Queen = 12,
        King = 13
    }

    public Suits Suit;
    public Values Value;

    public Card(Suits suit, Values value) {
        this.Suit = suit;
        this.Value = value;
    }

    public string Name {
        get { return Value.ToString() + " of " + Suit.ToString(); }
    }

    private void button1_Click(object sender, EventArgs e) {
        Random random = new Random();
        Card card = new Card((Card.Suits)random.Next(4), (Card.Values)random.Next(1, 14));
        MessageBox.Show(card.Name);
    }
}
```

When you don't specify values, the first item in the list is equal to zero, the second is 1, the third is 2, etc.

Here's where we set the value of Card.Values.Ace to 1.

When you set up your Suit and Value fields, you can just use Suits instead of Card.Suits, since you're inside of the Card class.

The get accessor for the Name property can take advantage of the way an enum's ToString() method returns its name converted to a string.

Here's the code for the button that pops up the name of a random card.

Here's where we use the overloaded Random.Next() method to generate a random number that we cast to the enum.

We could use an array to create a deck of cards...

What if you want to create a class to represent a deck of cards? It would need a way to keep track of every card in the deck, and it'd need to know what order they were in. A Card array would do the trick—the top card in the deck would be at index 0, the next card at index 1, etc. Here's a starting point—a Deck that starts out with a full deck of 52 cards.

```
public class Deck {
    private Card[] cards = {
        new Card(Card.Suits.Spades, Card.Values.Ace),
        new Card(Card.Suits.Spades, Card.Values.Two),
        new Card(Card.Suits.Spades, Card.Values.Three),
        // ...
        new Card(Card.Suits.Diamonds, Card.Values.Queen),
        new Card(Card.Suits.Diamonds, Card.Values.King),
    };

    public void PrintCards() {
        for (int i = 0; i < cards.Length; i++)
            Console.WriteLine(cards[i].Name());
    }
}
```

This array declaration would continue all the way through the deck. It's just abbreviated here to save space.

... but what if you wanted to do more?

Think of everything you might need to do with a deck of cards, though. If you're playing a card game, you routinely need to change the order of the cards, and add and remove cards from the deck. You just can't do that with an array very easily.



How would you add a `Shuffle()` method to the Deck class that rearranges the cards in random order? What about a method to deal the first card off the top of the deck? How would you add a card to the deck?

Arrays are hard to work with

An array is fine for storing a fixed list of values or references. But once you need to move array elements around, or add more elements than the array can hold, things start to get a little sticky.

- 1 Every array has a length, and you need to know the length to work with it. You could use null references to keep some array elements empty:

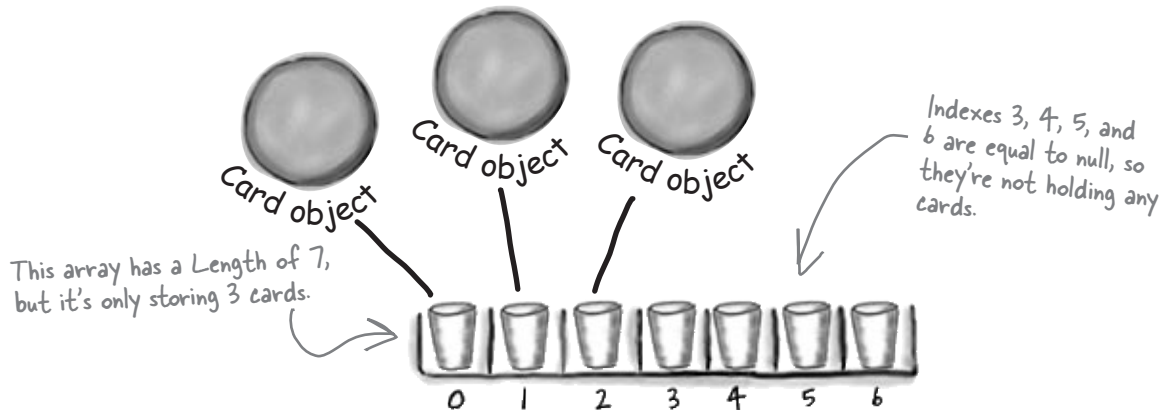

- 2 You'd need to keep track of how many cards are being held. So you'd need an int field, which we could call `topCard`, which would hold the index of the last card in the array. So our 3-card array would have a Length of 7, but we'd set `topCard` equal to 3.

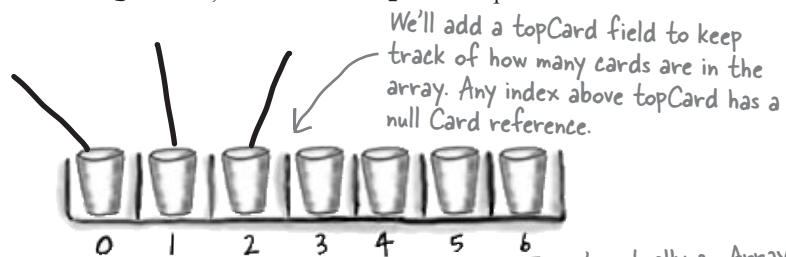

- 3 But now things get complicated. It's easy enough to add a `Peek()` method that just returns a reference to the top card—so you can peek at the top of the deck. But what if you want to add a card? If `topCard` is less than the array's Length, you can just put your card in the array at that index and add 1 to `topCard`. But if it's the array's full, you'll need to create a new, bigger array and copy the existing cards to it. Removing a card is easy enough—but after you subtract 1 from `topCard`, you'll need to make sure to set the removed card's array index back to null. And what if you need to remove a card **from the middle of the list**? If you remove card #4, you'll need to move card 5 back to replace it, and then move 6 back, then 7 back...wow, what a mess!

There's actually an `Array.Resize()` method built into the .NET Framework that does exactly that.

Lists make it easy to store collections of... anything

The .NET Framework has a bunch of **collection** classes that handle all of those nasty issues that come up with you add and remove array elements. The most common sort of collection is a **List**. Once you create a List object, it's easy to add an item, remove one from any location in the list, peek at an item, and even move an item from one place in the list to another. Here's how a list works:

1 First you create new instance of List

Every array has a type—you don't just have an array, you have an int array, a Card array, etc. Lists are the same way. You need to specify the type of object or value that the list will hold by putting it in angle brackets <> when you use the new keyword to create it.

```
List<Card> cards = new List<Card>();
```



← You specified <Card> when you created the list, so now this list only holds references to Card objects.

2 Now you can add to your List

Once you've got a List object, you can add as many items to it as you want (as long as they match whatever type you specified when you created your new List).

```
cards.Add(new Card(Card.Suits.Diamonds, Card.Values.King));
cards.Add(new Card(Card.Suits.Clubs, Card.Values.Three));
cards.Add(new Card(Card.Suits.Hearts, Card.Values.Ace));
```

You can add as many cards as you want to the List – just call its Add() method. It'll make sure it's got enough "slots" for the items. If it starts to run out, it'll automatically resize itself.

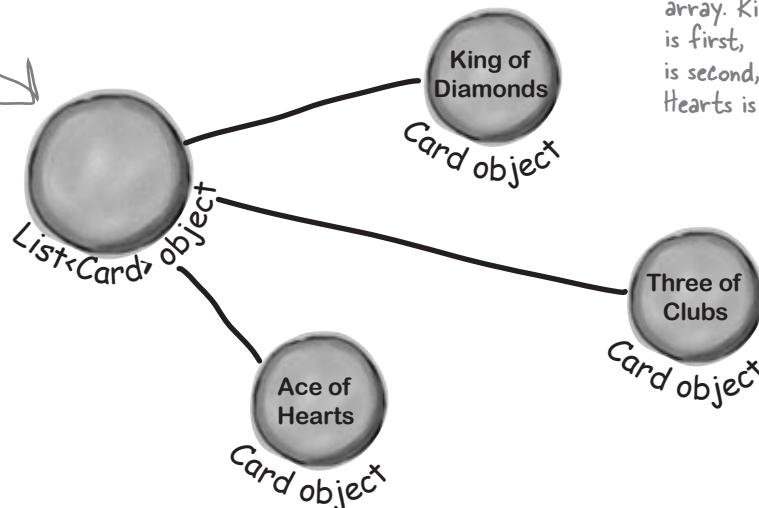

A list keeps its elements in order, just like an array. King of Diamonds is first, 3 of Clubs is second, and Ace of Hearts is third.

Lists are more flexible than arrays

The List class is built into the .NET Framework, and it lets you do a lot of things with objects that you can't do with a plain old array. Check out some of the things you can do with a List.

1 You can make one.

```
List<Egg> myCarton = new List<Egg>();
```

A new List object is created on the heap. But there's nothing in it yet.

2 Add something to it.

```
Egg x = new Egg();  
myCarton.Add(x);
```

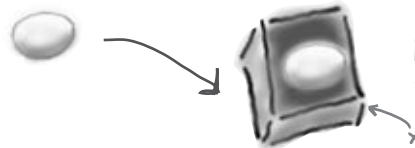

Now the List expands to hold the Egg object...

3 Add something else to it.

```
Egg y = new Egg();  
myCarton.Add(y);
```

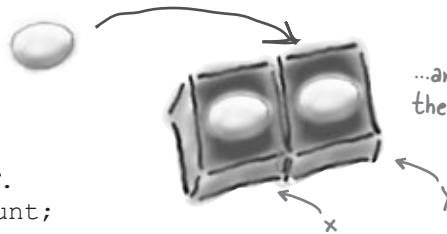

...and expands again to hold the second Egg object..

4 Find out how many things are in it.

```
int theSize = myCarton.Count;
```

5 Find out if it has something in particular in it.

```
bool Isin = myCarton.Contains(x);
```

Now you can search for any Egg inside the list. This would definitely come back true.

6 Figure out where that thing is.

```
int idx = myCarton.IndexOf(y);
```

The index for x would be 0 and the index for y would be 1.

7 Find out how much the list will hold.

```
int limit = myCarton.Capacity;
```

This will tell you the number of objects the list can hold before it has to resize itself.

8 Take something out if it.

```
myCarton.Remove(y);
```

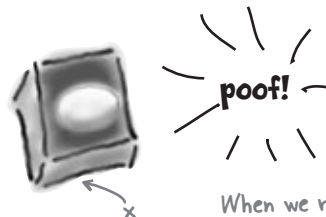

When we removed y, we left only x in the List, so it shrank!



Fill in the rest of the table below by looking at the List code on the left and putting in what you think the code might be if it were using a regular array instead. We don't expect you to get all of them exactly right, so just make your best guess.

Assume these statements are all executed in order, one after another.

List

We filled in a couple for you...

regular array

<code>List<String> myList = new List <String>();</code>	<code>String [] myList = new String[2];</code>
<code>String a = "Yay!";</code>	<code>String a = "Yay!";</code>
<code>myList.Add(a);</code>	
<code>String b = "Bummer";</code>	<code>String b = "Bummer";</code>
<code>myList.Add(b);</code>	
<code>int theSize = myList.Count;</code>	
<code>object o = myList[1];</code>	
<code>bool isIn = myList.Contains(b);</code>	
<p>Hint: You'll need than more than one line of code here. →</p>	



Your job was to fill in the rest of the table below by looking at the List code on the left and putting in what you think the code might be if it were using a regular array instead.

List	regular array
<code>List<String> myList = new List <String>();</code>	<code>String[] myList = new String[2];</code>
<code>String a = "Yay!";</code>	<code>String a = "Yay!";</code>
<code>myList.Add(a);</code>	<code>myList[0] = a;</code>
<code>String b = "Bummer";</code>	<code>String b = "Bummer";</code>
<code>myList.Add(b);</code>	<code>myList[1] = b;</code>
<code>int theSize = myList.Count;</code>	<code>int theSize = myList.Length;</code>
<code>object o = myList[1];</code>	<code>object o = myList[1];</code>
<code>bool isIn = myList.Contains(b);</code>	<code>bool isIn = false; for (int i = 0; i < myList. Length; i++) { if (b == myList[i]) { isIn = true; } }</code>

↑

Lists are objects that use methods just like every other class you've used so far. You can see the list of methods available from within the IDE just by typing a `.` next to the List name and you pass parameters to them just the same as you would for a class you created yourself.

↑

With arrays you're a lot more limited. You need to set the size of the array when you create it, and any logic that'll need to be performed on it will need to be written on your own.

↑

The .NET Framework does have an Array class which makes some of these things a little easier to do... but we're concentrating on List objects because they're a lot easier to use.

Lists shrink and grow dynamically

The great thing about a `List` is that you don't need to know how long it'll be when you create it. A `List` automatically grows and shrinks to fit its contents. Here's an example of a few of the methods that make working with Lists a lot easier than arrays:

```
List<Shoe> shoeCloset = new List<Shoe>();

shoeCloset.Add(new Shoe()
    { Style = Style.Sneakers, Color = "Black" });
shoeCloset.Add(new Shoe()
    { Style = Style.Clogs, Color = "Brown" });
shoeCloset.Add(new Shoe()
    { Style = Style.Wingtips, Color = "Black" });
shoeCloset.Add(new Shoe()
    { Style = Style.Loafers, Color = "White" });
shoeCloset.Add(new Shoe()
    { Style = Style.Loafers, Color = "Red" });
shoeCloset.Add(new Shoe()
    { Style = Style.Sneakers, Color = "Green" });
```

We're declaring a List of Shoe objects called shoeCloset.

You can use a new statement inside the List.Add() method.

```
int numberOfShoes = shoeCloset.Count;
foreach (Shoe shoe in shoeCloset) {
    shoe.Style = Style.Flipflops;
    shoe.Color = "Orange";
}
```

This returns the total number of Shoe objects in the List.

foreach loops work on arrays, too! In fact, they work on any collection.

This foreach loop goes through each of the shoes in the closet.

The Remove() method will remove the object by it's reference; RemoveAt() does it by index number.

```
shoeCloset.RemoveAt(4);
```

The Clear() method removes all of the objects in a List.

```
Shoe thirdShoe = shoeCloset[3];
Shoe fifthShoe = shoeCloset[5];
shoeCloset.Clear();
```

We saved references to two shoes before we cleared the list. We added one back, but the other's still missing.

```
shoeCloset.Add(thirdShoe);
if (shoeCloset.Contains(fifthShoe))
    Console.WriteLine("That's surprising.");
```

This line will never run, because Contains() will return false. We only added thirdShoe into the cleared list, not fifthShoe.

Here's the Shoe class we're using..

```
public class Shoe {
    public Style Style;
    public string Color;
}

public enum Style {
    Sneakers,
    Loafers,
    Sandals,
    Flipflops,
    Wingtips,
    Clogs,
}
```

Remember, the Style enum isn't inside the Shoe class, so it's just "Style.Sneakers", not "Shoe.Style.Sneakers".

List objects can store any type

You've already seen that a List can store strings or Shoes. You could also make Lists of integers, or any other object you can create. That makes a List a **generic collection**. When you create a new List object, you tie it to a specific type: you can have a list of ints, or strings, or Shoe objects. That makes working with Lists easy—once you've created your list, you always know the type of data that's inside it.

This doesn't actually mean that you add the letter T. It's notation that you'll see whenever a class or interface works with all types. The <T> part means you can put a type in there, like List<Shoe>, which limits its members to that type.

```
List<T> name = new List<T>();
```

Lists can be either very flexible (allowing any type) or very restrictive. So they do what arrays do, and then quite a few things more.

The .NET Framework comes with some generic interfaces that let the collections you're building work with any and all types. List implements those interfaces and that's why you could create a List of integers and work with it using pretty much the same way that you would work with a List of Shoe objects.

→ **Check it out for yourself.** Type the word, List, into the IDE and then right-click on it and select "Go To Definition". That will take you to the declaration for the List class. It implements a few interfaces:

This is where RemoveAt(), IndexOf(), and Insert() come from.

```
public class List<T> : IList<T>,
    ICollection<T>, IEnumerable<T>, IList,
    ICollection, IEnumerable
```

This is where Add(), Clear(), CopyTo(), and Remove() come from. It's the basis for all generic collections.

This interface lets you use foreach among other things.



BULLET POINTS

- List is a class in the .NET Framework.
- A List **resizes dynamically** to whatever size is needed. It's got a certain capacity—once you add enough data to the list, it'll grow to accommodate it.
- To put something into an List, use **Add()**. To remove something from a List, use **Remove()**.
- You can remove objects using their index number using **RemoveAt()**.
- You declare the type of the List using a **type argument**, which is a type name in angle brackets. Example: List<Frog> means the List will be able to hold only objects of type Frog.
- To find out where something is (and if it is) in a List, use **IndexOf()**.
- To get the number of elements in a List, use the **Count** property.
- You can use the **Contains()** method to find out if a particular object is in a List.
- **foreach** is a special kind of loop that will iterate through all of the elements in a list and execute code on it. The syntax for a foreach loop is **foreach (string s in StringList)**. You don't have to tell the foreach loop to increment by one; it will go through the entire list all on its own.



Code Magnets

Can you reconstruct the code snippets to make a working Windows Form that will pop up the message box below when you click a button?

```
private void button1_Click(object sender, EventArgs e){
```

```
    a.RemoveAt(2);
```

```
    List<string> a = new List<string>();
```

```
    public void printL (List<string> a){
```

```
        if (a.Contains("two")) {
            a.Add(twopointtwo);
        }
```

```
        a.Add(zilch);
        a.Add(first);
        a.Add(second);
        a.Add(third);
```

```
    }
```

```
    string result = "";
```

```
    if (a.Contains("three")){
        a.Add("four");
    }
```

```
    foreach (string element in a)
    {
        result += "\n" + element;
    }
```

```
    MessageBox.Show(result);
```

```
    if (a.IndexOf("four") != 4) {
        a.Add(fourth);
    }
```

```
    printL(a);
```

```
    string zilch = "zero";
    string first = "one";
    string second = "two";
    string third = "three";
    string fourth = "4.2";
    string twopointtwo = "2.2";
```

```
zero
one
three
four
4.2
```

OK



Code Magnets Solution

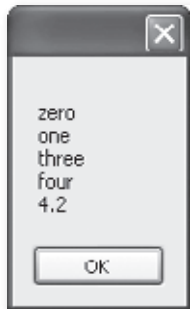

```
private void button1_Click(object sender, EventArgs e){
```

```
List<string> a = new List<string>();
```

```
string zilch = "zero";
string first = "one";
string second = "two";
string third = "three";
string fourth = "4.2";
string twopointtwo = "2.2";
```

```
a.Add(zilch);
a.Add(first);
a.Add(second);
a.Add(third);
```

```
if (a.Contains("three")){
    a.Add("four");
}
```

```
a.RemoveAt(2);
```

```
if (a.IndexOf("four") != 4) {
    a.Add(fourth);
}
```

```
if (a.contains("two")) {
    a.Add(twopointtwo);
}
```

```
printL(a);
```

```
}
```

```
public void printL (List<string> a){
```

```
string result = "";
```

```
foreach (string element in a)
{
    result += "\n" + element;
}
```

```
MessageBox.Show(result);
```

```
}
```

```
}
```

Can you figure out why "2.2" never gets added to the list, even though it's declared here?

RemoveAt() removes the element at index #2—which is the third element in the list.

The foreach loop goes through all of the elements in the list and prints them.

The printL() method uses a foreach loop to go through a list of strings, add each of them to one big string, and then show it in a message box.

there are no Dumb Questions

Q: So why would I ever use an enum instead of a List? Don't they solve the same problem?

A: Enums are a little different than Lists. You can think of enums as a handy way to store *lists of constants* so you can refer to them by name. They're great for keeping your code readable and making sure that you are always using the right variable names to access values that you use really frequently.

A List can store just about anything. Since it's a list of *objects*, each element in a list can have its own methods and properties. Enums, on the other hand, have to be assigned one of the *value types* in C# (like the ones on the first page of Chapter 4). So, you can't store reference variables in them.

Enums can't dynamically change their size either. They can't implement interfaces or have methods, and you'll have to cast them to another type to store a value from an enum in another variable. Add all of that up and you've got some pretty big differences between the two ways of storing data. But both are really useful in their own right.

Q: OK, it sounds like Lists are pretty powerful. So why would I ever want to use an array?

A: Arrays take up less memory and take less CPU time for your programs. If you're doing something that's really performance-intensive—like the same operation thousands and thousands of

↑ Okay, honestly, we're talking about a really, really tiny performance boost. Like if you have to do the same thing millions of times a second, use an array and not a list.

times—then you might find that a List will cause your program to slow down significantly. Luckily, you can easily convert any list to an array using the `ToArray()` method... and you can convert an array to a list using one of the overloaded constructors for the `List` object.

Q: I don't get the name "generic". Why is it called a generic collection? Why isn't an array one?

A: A generic collection is a collection object (or a built-in object that lets you store and manage a bunch of other objects) that's been set up to store only one type.

Q: Okay, that explains the "collection" part. But what makes it "generic"?

A: Supermarkets used to carry generic items that were packaged in big white packages with black type that just said the name of what was inside ("Potato Chips", "Cola", "Soap", etc.). The generic brand was all about what's inside the bag, and not about how it's displayed.

The same thing happens with generic data types. Your `List<>` will work exactly the same with whatever happens to be inside it. A List of Shoe objects, Card objects, ints, longs, or even other Lists will still act at the container level. So you can always add, remove, insert, etc., no matter what's inside the list itself.

↑ The term "generic" refers to the fact that even though a specific instance of List can only store one specific type, the List class in general works with any type.

↑ That's what the `<T>` stuff is all about. It's the way that you tie a specific instance of a List to one type. But the List class as a whole is generic enough to work with ANY type. That's why generic collections are different from anything you've seen so far.

Q: Can I have a list that doesn't have a type?

A: No. Every list—in fact, every generic collection (and you'll learn about the other generic collections in just a minute)—must have a type connected to it. C# does have non-generic lists called `ArrayLists` that can store any kind of object. If you want to use an `ArrayList`, you need to include a `"using System.Collections;"` line in your code.

Generic collections are actually a recent addition to C#—they didn't exist in the early versions of the language. But they're so useful that people rarely use non-generic collections any more... which is why we won't be talking much about them.

When you create a new List object, you always supply a type—that tells C# what type of data that it'll store. A list can store a value type (like int, bool, or string) or a class.

Collection initializers work just like object initializers

C# gives you a nice bit of shorthand to cut down on typing when you need to create a list and immediately add a bunch of items to it. When you create a new List object, you can use a **collection initializer** to give it a starting list of items. It'll add them as soon as the list is created.

You saw this code a few pages ago—it creates a new List<Shoe> and fills it with new Shoe objects.

```
List<Shoe> shoeCloset = new List<Shoe>();
shoeCloset.Add(new Shoe() { Style = Style.Sneakers, Color = "Black" });
shoeCloset.Add(new Shoe() { Style = Style.Clogs, Color = "Brown" });
shoeCloset.Add(new Shoe() { Style = Style.Wingtips, Color = "Black" });
shoeCloset.Add(new Shoe() { Style = Style.Loafers, Color = "White" });
shoeCloset.Add(new Shoe() { Style = Style.Loafers, Color = "Red" });
shoeCloset.Add(new Shoe() { Style = Style.Sneakers, Color = "Green" });
```

Collection Initializers are a C# 3.0 feature. If you're still using Visual Studio 2005, you should download Visual Studio 2008 Express for free from Microsoft, otherwise this code won't work.

The same code rewritten using a collection initializer

You can create a collection initializer by taking each item that was being added using Add() and adding them to the statement that creates the list.

```
List<Shoe> shoeCloset = new List<Shoe>() {
    new Shoe() { Style = Style.Sneakers, Color = "Black" },
    new Shoe() { Style = Style.Clogs, Color = "Brown" },
    new Shoe() { Style = Style.Wingtips, Color = "Black" },
    new Shoe() { Style = Style.Loafers, Color = "White" },
    new Shoe() { Style = Style.Loafers, Color = "Red" },
    new Shoe() { Style = Style.Sneakers, Color = "Green" },
};
```

The statement to create the list is followed by curly brackets that contain separate new statements, separated by commas.

You're not limited to using new statements in the initializer—you can include variables, too.

A collection initializer makes your code more compact by letting you combine creating a list with adding an initial set of items.

Let's create a list of Ducks

Here's a duck class that keeps track of your extensive duck collection. (You *do* collect ducks, don't you?)

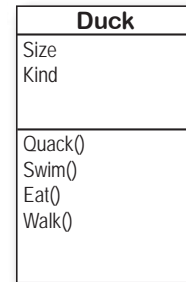
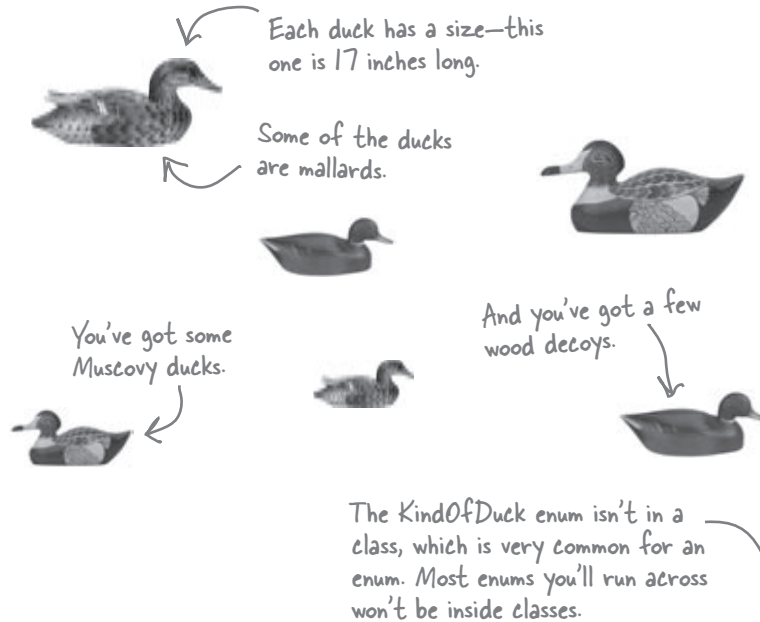

```
public class Duck {
    public int Size;
    public KindOfDuck Kind;
}
```

The class has two public fields. It's also got some methods, which we're not showing here.

```
public enum KindOfDuck {
    Mallard,
    Muscovy,
    Decoy
}
```

We'll use an enum called `KindOfDuck` to keep track of what sort of ducks are in your collection.

Here's the initializer

We've got six ducks, so we'll create a `List<Duck>` that has a collection initializer with six statements. Each statement in the initializer creates a new duck, using an object initializer to set each Duck object's `Size` and `Kind` field.

```
List<Duck> ducks = new List<Duck>() {
    new Duck() { Kind = KindOfDuck.Mallard, Size = 17 },
    new Duck() { Kind = KindOfDuck.Muscovy, Size = 18 },
    new Duck() { Kind = KindOfDuck.Decoy, Size = 14 },
    new Duck() { Kind = KindOfDuck.Muscovy, Size = 11 },
    new Duck() { Kind = KindOfDuck.Mallard, Size = 14 },
    new Duck() { Kind = KindOfDuck.Decoy, Size = 13 },
};
```

Lists are easy, but SORTING can be tricky

It's not hard to think about ways to sort numbers or letters. But what do you sort two objects on, especially if they have multiple fields? In some cases you might want to order objects by the value in a name field, while in other cases it might make sense to order objects based on height or date of birth. There are lots of ways you can order things, and Lists support any of them.

You could sort a list of ducks by size...



...or by type.



Lists know how to sort themselves

Every list comes with a `Sort()` method that rearranges all of the items in the list to put them in order. Lists already know how to sort most built-in types and classes, and it's easy to teach it how to sort your own classes.

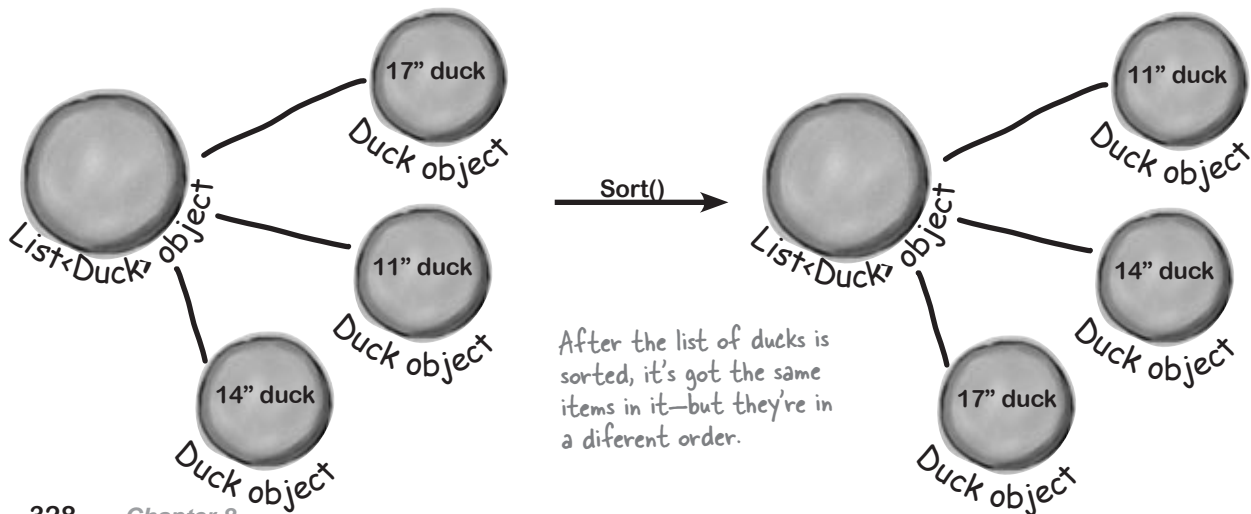

Two ways to sort your ducks

The `List.Sort()` method already knows how to sort any type or class that implements the `IComparable` interface. That interface has just one member—a method called `CompareTo()`. `Sort()` uses an object's `CompareTo()` method to compare it with other objects, and uses its return value (an `int`) to determine which comes first.

But sometimes you need to sort a list of objects that don't implement `IComparable`, and .NET has another interface to help with that. You can pass `Sort()` an instance of a class that implements `IComparer`. That interface also has one method. The `List`'s `Sort()` method uses the comparer object's `Compare()` method to compare pairs of objects, in order to figure out which one comes first in the sorted list.

An object's `CompareTo()` method compares it with another object

One way to let our `List` object sort is to modify the `Duck` class to implement `IComparable`. To do that, we'd add a `CompareTo()` method that takes a `Duck` reference as a parameter. If the duck to compare should come after the current duck in the sorted list, `CompareTo()` returns a positive number.

Here's a `Duck` class that sorts itself based on duck size:

```
public class Duck : IComparable<Duck> {
    public int Size;
    public KindOfDuck Kind;

    public int CompareTo(Duck duckToCompare) {
        if (this.Size > duckToCompare.Size)
            return 1;
        else if (this.Size < duckToCompare.Size)
            return -1;
        else
            return 0;
    }
}
```

When you implement `IComparable`, you specify the type being compared when you have the class implement the interface.

Most `CompareTo()` methods look a lot like this. This method first compares the `Size` field against the other duck's `Size` field. If this duck is bigger, it returns 1. If it's smaller, it returns -1. And if they're the same size, it returns zero.

If you want to sort your list from smallest to biggest, have `CompareTo()` return a positive number if it's comparing to a smaller duck, and a negative number if it's comparing to a bigger one.



You can make any class work with the `List`'s built-in `Sort()` method by having it implement `IComparable` and adding a `CompareTo()` method.

Use IComparer to tell your List how to sort

Lists have a special interface built into the .NET Framework that lets you build a separate class to help the `List` sort out its members. By implementing the **IComparer** interface, you can tell your `List` exactly how you want it to sort your objects. You do that by implementing the `Compare()` method in the `IComparer` interface. It takes two object parameters, `x` and `y`, and returns an `int`. If `x` is less than `y`, it should return a negative value. If they're equal, it should return zero. And if `x` is greater than `y`, it should return a positive value.

Here's an example of how you'd declare a comparer class to compare duck objects by size:

```
public class DuckComparer_bySize : IComparer<Duck>
{
    public int Compare(Duck x, Duck y)
    {
        if (x.Size < y.Size)
            return -1;
        if (x.Size > y.Size)
            return 1;
        return 0;
    }
}
```

This class implements IComparer, and specifies the type of object it can sort: Duck objects.

These will always match: the same type in each.

The Compare() method returns an int, and has two parameters: both of the type you're sorting.

You can do whatever types of comparisons you want in the method.

A -1 means object x should go before object y. x is "less than" y.

Positive 1 means object x should go after object y. x is "greater" than y.

0 means that these two objects should be treated as the same (using this comparison calculation).

Your List will sort differently depending on how you implement IComparer.

Create an instance of your comparer object

When you want to sort using `IComparer`, you need to create a new instance of the class that implements it. That object exists for one reason—to help `List.Sort()` figure out how to sort the array. But like any other (non-static) class, you need to instantiate it before you use it.

```
List<Duck> ducks = new List<Duck>() { ... };
DuckComparer_bySize dc = new DuckComparer_bySize();
ducks.Sort(dc);
```

You'll pass `Sort()` a reference to the new `DuckComparer_bySize` object as its parameter.

We left out the code you already saw a few pages ago to initialize the list.



Multiple `IComparer` implementations, multiple ways to sort your objects

You can create multiple `IComparer` classes with different sorting logic depending on what you need to do. Then you can call the comparer you want when you need to sort in that particular way. Here's another duck comparer implementation:

```
class DuckComparer_byKind : IComparer<Duck> {
    public int Compare(Duck x, Duck y) {
        if (x.Kind < y.Kind)
            return -1;
        if (x.Kind > y.Kind)
            return 1;
        else
            return 0;
    }
}
```

This comparer sorts by duck type. Remember, when you compare the enum `Kind`, you're comparing their index values.

So Mallard comes before Muscovy, which comes before Decoy.

We compared the ducks' `Kind` properties, so the ducks are sorted based on the index value of the `KindOfDuck` enum.

Notice how "greater than" and "less than" have a different meaning here. We used `<` and `>` to compare enum index values, which lets us put the ducks in order.

Here's an example of how enums and Lists work together. Enums stand in for numbers, and are used in sorting of lists.

```
DuckComparer_byKind dcKind = new DuckComparer_byKind();
ducks.Sort(dcKind);
```



IComparer can do complex comparisons

One advantage to creating a separate class for sorting your ducks is that you can build more complex logic into that class—and you can add members that help determine how the list gets sorted.

```
public class DuckComparer : IComparer<Duck> {  
    public enum SortCriteria {  
        SizeThenKind,  
        KindThenSize,  
    }  
}
```

This enum tells the object which way to sort the ducks.

Here's a more complex class to compare ducks. Its Compare() method takes the same parameters, but it looks at the public SortBy field to determine how to sort the ducks.

```
public SortCriteria SortBy = SortCriteria.SizeThenKind;
```

```
public int Compare(Duck x, Duck y) {  
    if (SortBy == SortCriteria.SizeThenKind)  
        if (x.Size > y.Size)  
            return 1;  
        else if (x.Size < y.Size)  
            return -1;  
        else  
            if (x.Kind > y.Kind)  
                return 1;  
            else if (x.Kind < y.Kind)  
                return -1;  
            else  
                return 0;  
    else  
        if (x.Kind > y.Kind)  
            return 1;  
        else if (x.Kind < y.Kind)  
            return -1;  
        else  
            if (x.Size > y.Size)  
                return 1;  
            else if (x.Size < y.Size)  
                return -1;  
            else  
                return 0;  
}
```

This if statement checks the SortBy field. If it's set to SizeThenKind, then it first sorts the ducks by size, and then within each size it'll sort the ducks by their kind.

Instead of just returning 0 if the two ducks are the same size, the comparer checks their kind, and only returns 0 if the two ducks are both the same size and the same kind.

If SortBy isn't set to SizeThenKind, then the comparer first sorts by the kind of duck. If the two ducks are the same kind, then it compares their size.

```
DuckComparer dc = new DuckComparer();
```

```
dc.SortBy = DuckComparer.SortCriteria.KindThenSize;  
ducks.Sort(dc);
```

```
dc.SortBy = DuckComparer.SortCriteria.SizeThenKind;  
ducks.Sort(dc);
```

Here's how we'd use this comparer object. First we'd instantiate it as usual. Then we can set the object's SortBy field before calling ducks.Sort(). Now you can change the way the list sorts its ducks just by changing one field in the object.



Exercise

Create five random cards and then sort them.

1 Create code to make a jumbled set of cards

Add a button to a form that creates five random `Card` objects. After you create each object, use the built-in `Console.WriteLine()` method to write its name to the **output**. You can view everything written to the output by selecting “Output” from the View menu while the program’s running.

2 Create a class that implements `IComparer<List>` to sort the cards

Here’s a good chance to use that IDE shortcut to implement an interface:

```
public class CardComparer_byValue : IComparer<Card>
```

Then click on `IComparer` and hover over the `I`. You’ll see a box appear underneath it. When you click on the box, the IDE pops up a window:

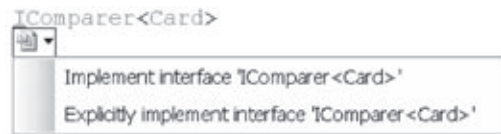

If you click on “Implement interface `IComparer<Card>`”, the IDE automatically fills in all of the methods and properties that you need to implement. In this case, it creates an empty `Compare()` method to compare two cards, `x` and `y`. Write the method so that it returns 1 if `x` is bigger than `y`, -1 if it’s smaller, and 0 if they’re the same card. In this case, make sure that any king comes after any jack, which comes after any four, which comes after any ace.

3 Make sure the output looks right

Here’s what your output window should look like after you click the button.

When you use the built-in `Console.WriteLine()` method, it adds a line to this output window.

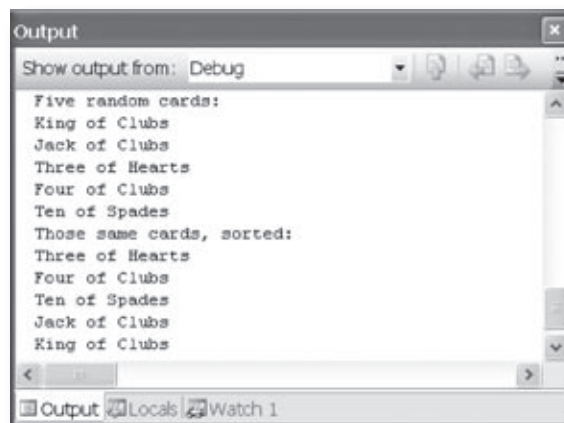

Your `IComparer` object needs to sort the cards by value, so the cards with the lowest values are first in the list.



Exercise Solution

Create five random cards and then sort them.

Here's the "guts" of the card sorting, which uses the built-in `List.Sort()` method. `Sort()` takes an `IComparer` object, which has one method: `Compare()`. This implementation takes two cards and first compares their values, then their suits.

```
public class CardComparer_byValue : IComparer<Card> {
    public int Compare(Card x, Card y) {
        if (x.Value < y.Value) {
            return -1;
        }
        if (x.Value > y.Value) {
            return 1;
        }
        if (x.Suit < y.Suit) {
            return -1;
        }
        if (x.Suit > y.Suit) {
            return 1;
        }
        return 0;
    }
}
```

If `x` has a bigger value, return 1. If `x`'s value is smaller, return -1. Remember, both return statements end the method immediately.

These statements only get executed if `x` and `y` have the same value—that means the first two return statements weren't executed.

If none of the other four return statements were hit, the cards must be the same—so return zero.

```
private void button1_Click(object sender, EventArgs e)
{
    Console.WriteLine("Five random cards:");
    List<Card> cards = new List<Card>();
    for (int i = 0; i < 5; i++)
    {
        cards.Add(new Card((Card.Suits)random.Next(4),
                           (Card.Values)random.Next(1, 14)));
        Console.WriteLine(cards[i].Name);
    }

    Console.WriteLine("Those same cards, sorted:");
    cards.Sort(new CardComparer_byValue());
    foreach (Card card in cards)
    {
        Console.WriteLine(card.Name);
    }
}
```

Here's a generic `List` of `Card` objects to store the cards. Once they're in the list, it's easy to sort them using an `IComparer`.

Use a dictionary to store keys and values

A list is like a big long page full of names. But what if you want, for each name, an address? Or for every car in the garage list, you want details about that car? You need a **dictionary**. A dictionary lets you take a special value—the **key**—and associate that key with a bunch of data—the **value**. And one more thing: a specific key can **only appear once** in any dictionary.

This is the key. It's how you look up a definition in (you guessed it) a dictionary.

dic·tion·ary

A book that lists the words of a language in alphabetical order and gives their meaning.

This is the value. It's the data associated with a particular key.

Here's how you declare a Dictionary in C#:

```
Dictionary <Tkey, TValue> kv = new Dictionary <TKey, TValue>();
```

These are like List<T>. The <T> means a type goes in there. So you can declare one type for the key, and another type for the value.

These represent types. The first type in the angle brackets is always the key, and the second is always the data.

And here's a Dictionary in action:

```
private void button1_Click(object sender, EventArgs e)
{
```

```
    Dictionary<string, string> wordDefinition =
        new Dictionary<string, string>();
```

This dictionary has string values for keys, and strings as the value. It's like a real dictionary: term, and definition.

The Add() method is how you add keys and values to the dictionary.

```
        wordDefinition.Add ("Dictionary", "A book that lists the words of a "
            + "language in alphabetical order and gives their meaning");
        wordDefinition.Add ("Key", "A thing that provides a means of gaining access to "
            + "our understanding something.");
        wordDefinition.Add ("Value", "A magnitude, quantity, or number.");
```

Add() takes a key, and then the value.

```
        if (wordDefinition.ContainsKey("Key"))
            MessageBox.Show(wordDefinition["Key"]);
    }
```

ContainsKey() tells you if a key is in the dictionary. Handy, huh?

Here's how you get the value for a key. It looks kind of like an array index—get the value for the key at this index.

The Dictionary Functionality Rundown

Dictionaries are a lot like Lists. Both types are flexible in letting you work with lots of data types, and also come with lots of built-in functionality. Here are the basic Dictionary methods:

★ Add an item.

You can add an item to a dictionary by passing a key and a value to its the `Add()` method.

```
Dictionary<string, string> myDictionary = new Dictionary<string, string>();

myDictionary.Add("some key", "some value");
```

★ Look up a value using its key.

The most important thing you'll do with a dictionary is look up values—which makes sense, because you stored those values in a dictionary so you could look them up using their unique keys.

```
string lookupValue = myDictionary["some key"];
```

★ Remove an item.

Just like a List, you can remove an item from a dictionary using the `Remove()` method. All you need to pass to the `Remove` method is the Key value to have both the key and the value removed.

```
myDictionary.Remove("some key");
```

Keys are unique in a Dictionary; any key appears exactly once. Values can appear any number of times—two keys can have the same value. That way, when you look up or remove a key, the Dictionary knows what to remove.

★ Get a list of keys.

You can get a list of all of the keys in a Dictionary using a `KeyCollection` and loop through it using a `foreach` loop. You'll usually use a `KeyCollection` like this:

```
foreach (string key in myDictionary.Keys) { ... };
```

Keys is a property of your dictionary object. This particular dictionary has string keys, so `Keys` is a collection of strings.

★ Get a list of values.

You can get a list of all of the values in a Dictionary using a `ValueCollection`. Most of the time, you use a `ValueCollection` with a `foreach` loop too:

```
foreach (string value in myDictionary.Values) { ... };
```

Since this dictionary has string values, the `foreach` identifier will be a string.

Your key and value can be different types, too

Dictionaries are really versatile and can hold just about anything, from strings to numbers and even objects. Here's an example of a dictionary that's storing an integer as a key and a duck object as a value. The Duck object has a `Size` field and `Types` enum that are set inside its constructor.

Here's where the dictionary is declared. It'll store numbers and ducks. We'll add each of the ducks to the dictionary, giving it a unique ID number as the key.

```
Dictionary<int, Duck> duckDictionary = new Dictionary<int, Duck>();
duckDictionary.Add(5155, new Duck() { Kind = KindOfDuck.Mallard, Size = 15 });
duckDictionary.Add(6256, new Duck() { Kind = KindOfDuck.Mallard, Size = 14 });
duckDictionary.Add(2799, new Duck() { Kind = KindOfDuck.Mallard, Size = 13 });
```

The `Count` property tells how many key-value pairs are in the Dictionary.

```
int howMany = duckDictionary.Count;
Console.WriteLine("There are {0} ducks.", howMany);
```

If you need to pull the keys and values out of a dictionary, you can use a `KeyValuePair<>`.

This loop assigns the current key/value pair to `idDuck`, one at a time, through the whole loop.

```
foreach (KeyValuePair<int, Duck> idDuck in duckDictionary)
    Console.WriteLine("Key/value pair: {0}: {1}, {2}",
        idDuck.Key, idDuck.Value.Size, idDuck.Value.Kind.ToString());
```

Every `KeyValuePair` has a key and a value. Since the value is a `Duck`, you can use its fields.

```
foreach (Duck duck in duckDictionary.Values)
    Console.WriteLine("Duck size: {0}", duck.Size);
```

This `foreach` loop goes through all of the values in the dictionary.

```
foreach (int key in duckDictionary.Keys)
```

```
    Console.WriteLine("ID Number: {0}", key);
```

And this `foreach` loop pulls each of the keys out of the dictionary.

```
Output
Show output from: Debug
Key/value pair: 5155: 15, Mallard
Key/value pair: 6256: 14, Mallard
Key/value pair: 2799: 13, Mallard
Duck size: 15
Duck size: 14
Duck size: 13
ID Number: 5155
ID Number: 6256
ID Number: 2799
```

Here's the output that this code writes to the console.



Exercise

1 Build a form that lets you move cards between two decks

You've built a card class already. Now it's time to build a class to hold any number of cards, which we'll call `Deck`. A real-life deck has 52 cards, but the `Deck` class can hold any number of cards—or no cards at all.

Then you'll build a form that shows you the contents of two `Deck` objects. When you first start the program, deck #1 has up to 10 random cards, and deck #2 is a complete deck of 52 cards, both sorted by suit and then value—and you can reset either deck to its initial state using two `Reset` buttons. The form also has buttons (labeled “<<” and “>>”) to move cards between the decks.

These buttons are named `moveToDeck2` (top) and `moveToDeck1` (bottom). They move cards from one deck to the other.

You can use a button's `Name` property to give it a name to make your code easier to read. Then when you double-click on the button, its event handler is given a matching name.

Each of the `reset1` and `reset2` buttons first calls the `ResetDeck()` method and then the `RedrawDeck()` method.

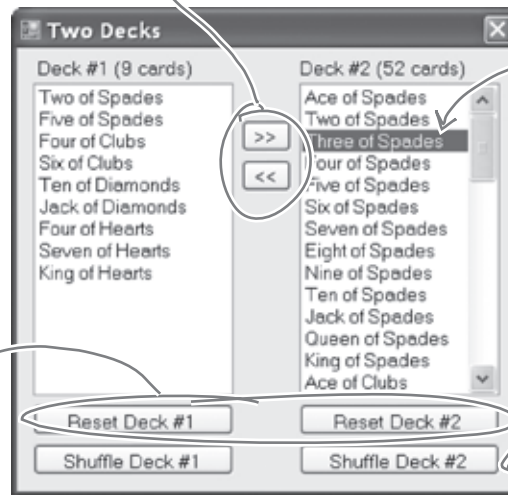

Use two `ListBox` controls to show the two decks. When the `moveToDeck1` button is clicked, it moves the selected card from deck #2 to deck #1.

These buttons are named `shuffle1` and `shuffle2`. They call the appropriate `Deck.Shuffle()` method, and then redraw the deck.

In addition to the event handlers for the six buttons, you'll need to add two methods for the form. First add a `ResetDeck()` method, which resets a deck to its initial state. It takes an `int` as a parameter: if it's passed 1, it resets the first `Deck` object by reinitializing it to an empty deck and a random number of up to 10 random cards; if it's passed 2, it resets the second `Deck` object so that it contains a full 52-card deck. Then add this method:

```
private void RedrawDeck(int DeckNumber) {
    if (DeckNumber == 1) {
        listBox1.Items.Clear();
        foreach (string cardName in deck1.GetCardNames())
            listBox1.Items.Add(cardName);
        label1.Text = "Deck #1 (" + deck1.Count + " cards)";
    } else {
        listBox2.Items.Clear();
        foreach (string cardName in deck2.GetCardNames())
            listBox2.Items.Add(cardName);
        label2.Text = "Deck #2 (" + deck2.Count + " cards)";
    }
}
```

Take a look at how we used the `foreach` loop to add each of the cards in the deck to the listbox.

The `RedrawDeck()` method updates the two listbox controls with whatever happens to be in the two `Deck` objects.

2

Build the Deck class

When you have the declarations for a class without the implementation, it's called a "skeleton".

Here's the skeleton for the Deck class. We've filled in several of the methods for you. You'll need to finish it by writing the `Shuffle()` and `GetCardNames()` methods, and you'll have to get the `Sort()` method to work. We also added two useful **overloaded constructors**: one that creates a complete deck of 52 cards, and the other that takes an array of `Card` objects and loads them into the deck.

```
public class Deck {
    private List<Card> cards;
    private Random random = new Random();

    public Deck() {
        cards = new List<Card>();
        for (int suit = 0; suit <= 3; suit++)
            for (int value = 1; value <= 13; value++)
                cards.Add(new Card((Card.Suits)suit, (Card.Values)value));
    }

    public Deck(Card[] initialCards) {
        cards = new List<Card>(initialCards);
    }

    public int Count { get { return cards.Count; } }

    public void Add(Card cardToAdd) {
        cards.Add(cardToAdd);
    }

    public Card Deal(int index) {
        Card CardToDeal = cards[index];
        cards.RemoveAt(index);
        return CardToDeal;
    }

    public void Shuffle() {
        // this method shuffles the cards by rearranging them in a random order
    }

    public string[] GetCardNames() {
        // this method returns a string array that contains each card's name
    }

    public void Sort() {
        cards.Sort(new CardComparer_bySuit());
    }
}
```

The Deck stores its cards in a List—but it keeps it private to make sure it's well-encapsulated.

If you don't pass parameters into the constructor, it creates a complete deck of 52 cards.

This overloaded constructor takes one parameter—an array of cards, which it loads as the initial deck.

The Deal method deals one card out of the deck—it removes the Card object from the deck and returns a reference to it. You can deal from the top by passing it 0, or deal from the middle of the deck by passing it the index of the card to deal.

Hint: The `ListBox` control's `SelectedIndex` property will be the same as the index of the card in the list. You can pass it directly to the `Deal()` method. If no card is selected, it'll be less than zero. In that case, the `moveToDeck` button should do nothing.

You'll need to write the `Shuffle()` method, the `GetCardNames()` method, and add a class that implements `IComparer` to make the `Sort()` method work. And you'll need to add the `Card` class you already wrote. If you use "Add Existing Item" to add it, don't forget to change its namespace.

Another hint: The form makes it really easy to test your `Shuffle()` method. Keep clicking the "Reset Deck #1" button until you get a three-card deck. That'll make it easy to see if your shuffling code works.

Deck
Count
Add() Deal() GetCardNames() Shuffle() Sort()



Exercise Solution

Build a class to store a deck of cards, along with a form that uses it.

```

public class Deck {
    private List<Card> cards;
    private Random random = new Random();
    public Deck() {
        cards = new List<Card>();
        for (int suit = 0; suit <= 3; suit++)
            for (int value = 1; value <= 13; value++)
                cards.Add(new Card((Card.Suits)suit, (Card.Values)value));
    }
    public Deck(Card[] initialCards) {
        cards = new List<Card>(initialCards);
    }
    public int Count { get { return cards.Count; } }
    public void Add(Card cardToAdd) {
        cards.Add(cardToAdd);
    }
    public Card Deal(int index) {
        Card CardToDeal = cards[index];
        cards.RemoveAt(index);
        return CardToDeal;
    }
    public void Shuffle() {
        List<Card> NewCards = new List<Card>();
        while (cards.Count > 0) {
            int CardToMove = random.Next(cards.Count);
            NewCards.Add(cards[CardToMove]);
            cards.RemoveAt(CardToMove);
        }
        cards = NewCards;
    }
    public string[] GetCardNames() {
        string[] CardNames = new string[cards.Count];
        for (int i = 0; i < cards.Count; i++)
            CardNames[i] = cards[i].Name;
        return CardNames;
    }
    public void Sort() {
        cards.Sort(new CardComparer_bySuit());
    }
}
    
```

Here's the constructor that creates a complete deck of 52 cards. It uses a nested for loop. The outside one loops through the four suits. That means the inside loop that goes through the 13 values runs four separate times, once per suit.

Here's the other constructor—this class has two overloaded constructors, each with different parameters.

The Add and Deal methods are pretty straightforward—they use the methods for the Cards list. The Deal method removes a card from the list, and the Add method adds a card to the list.

The Shuffle() method creates a new instance of List<Cards> called NewCards. Then it pulls random cards out of the Cards field and sticks them in NewCards until Cards is empty. Once it's done, it resets the Cards field to point to the new instance. The old instance won't have any more references pointing to it, so it'll get collected by the garbage collector.

Your GetCardNames() method needs to create an array that's big enough to hold all the card names. This one uses a for loop, but it could also use foreach.

```

class CardComparer_bySuit : IComparer<Card>
{
    public int Compare(Card x, Card y)
    {
        if (x.Suit > y.Suit)
            return 1;
        if (x.Suit < y.Suit)
            return -1;
        if (x.Value > y.Value)
            return 1;
        if (x.Value < y.Value)
            return -1;
        return 0;
    }
}

```

Sorting by suit is a lot like sorting by value. The only difference is that in this case the suits are compared first, and then the values are compared only if the suits match.

Instead of using if/else if, we used a series of if statements. This works because each if statement only executes if the previous one didn't—otherwise the previous one would have returned.

```

Deck deck1;
Deck deck2;
Random random = new Random();

```

```

public Form1() {
    InitializeComponent();
    ResetDeck(1);
    ResetDeck(2);
    RedrawDeck(1);
    RedrawDeck(2);
}

```

The form's constructor needs to reset the two decks, and then it draws them.

```

private void ResetDeck(int deckNumber) {
    if (deckNumber == 1) {
        int numberOfCards = random.Next(1, 11);
        deck1 = new Deck(new Card[] { });
        for (int i = 0; i < numberOfCards; i++)
            deck1.Add(new Card((Card.Suits)random.Next(4),
                               (Card.Values)random.Next(1, 14)));
        deck1.Sort();
    } else
        deck2 = new Deck();
}

```

To reset deck #1, this method first uses `random.Next()` to pick how many cards will go into the deck, and then creates a new empty deck. It uses a for loop to add that many random cards. It finishes off by sorting the deck. Resetting deck #2 is a easy—just create a new instance of `Deck()`.

You've already got the `RedrawDeck()` method from the instructions.

→ We're not done yet—flip the page!



Exercise Solution (Continued)

Naming your controls makes it a lot easier to read your code. If these were called `button1_Click`, `button2_Click`, etc., you wouldn't know which button's code you were looking at!

Here's the rest of the code for the form.

```
private void reset1_Click(object sender, EventArgs e) {
    ResetDeck(1);
    RedrawDeck(1);
}

private void reset2_Click(object sender, EventArgs e) {
    ResetDeck(2);
    RedrawDeck(2);
}

private void shuffle1_Click(object sender, EventArgs e) {
    deck1.Shuffle();
    RedrawDeck(1);
}

private void shuffle2_Click(object sender, EventArgs e) {
    deck2.Shuffle();
    RedrawDeck(2);
}

private void moveToDeck1_Click(object sender, EventArgs e) {
    if (listBox2.SelectedIndex >= 0)
        if (deck2.Count > 0) {
            deck1.Add(deck2.Deal(listBox2.SelectedIndex));
        }
    RedrawDeck(1);
    RedrawDeck(2);
}

private void moveToDeck2_Click(object sender, EventArgs e) {
    if (listBox1.SelectedIndex >= 0)
        if (deck1.Count > 0)
            deck2.Add(deck1.Deal(listBox1.SelectedIndex));
    RedrawDeck(1);
    RedrawDeck(2);
}
}
```

These buttons are pretty simple—first reset or shuffle the deck, then redraw it.

You can use the `ListBox` control's `SelectedIndex` property to figure out which card the user selected and then move it from one deck to the other. (If it's less than zero, no card was selected, so the button does nothing.) Once the card's moved, both decks need to be redrawn.

You can build your own overloaded methods

You've been using **overloaded methods** and even an overloaded constructor that were part of the built-in .NET Framework classes and objects, so you can already see how useful they are. Wouldn't it be cool if you could build overloaded methods into your own classes? Well, you can—and it's easy! All you need to do is write two or more methods that have the same name but take different parameters.



1 Create a new project and add the Card class to it.

You can do this easily by right-clicking on the project in the Solution Explorer and selecting “Existing Item” from the Add menu. The IDE will make a copy of the class and add it to the project. The file will **still have the namespace from the old project**, so go to the top of the Card.cs file and change the namespace line to match the name of the new project you created.

If you don't do this, you'll only be able to access the Card class by specifying its namespace (like oldnamespace.Card).

2 Add some new overloaded methods to the card class.

Create two static `DoesCardMatch()` methods. The first one should check a card's suit. The second should check its value. Both return true only if the card matches.

```
public static bool DoesCardMatch(Card CardToCheck, Card.Suits Suit) {
    if (CardToCheck.Suit == Suit) {
        return true;
    } else {
        return false;
    }
}

public static bool DoesCardMatch(Card CardToCheck, Card.Values Value) {
    if (CardToCheck.Value == Value) {
        return true;
    } else {
        return false;
    }
}
```

Overloaded methods don't have to be static, but it's good to get a little practice writing static methods.

You've seen overloading already. Flip back to the solution to Kathleen's party planning program in Chapter 6 on pages 236–238—you added an overloaded `CalculateCost()` method to the `DinnerParty` class.

3 Add a button to the form to use the new methods.

Add this code to the button:

```
Card cardToCheck = new Card(Card.Suits.Clubs, Card.Values.Three);
bool doesItMatch = Card.DoesCardMatch(cardToCheck, Card.Suits.Hearts);
```

As soon as you type “`DoesCardMatch(`” the IDE will show you that you really did build an overloaded method:

Take a minute and play around with the two methods so you can get used to overloading.



LONG Exercise

Build a game of Go Fish! that you can play against the computer.

This exercise is a little different...

There's a good chance that you're learning C# because you want a job as a professional developer. That's why we modeled this exercise after a professional assignment. When you're working as a programmer on a team, you don't usually build a complete program from start to finish. Instead, you'll build a *piece* of a bigger program. So we're going to give you a puzzle that's got some of the pieces already filled in. The code for the form is all on the next page in step #3. You just have to type it in—which may seem like you've got a great head start, but it means that your classes *have to work with that code*. And that can be a challenge!

1

Start with the spec

Every professional software project starts with a specification, and this one is no exception. You'll be building a game of the classic card game **Go Fish!** Different people play the game by slightly different rules, so here's a recap of the rules you'll be using:

- ★ The game starts with a deck of 52 cards. Five cards are dealt to each player. The pile of cards that's left after everyone's dealt a hand is called the **stock**. Each player takes turns asking for a value (“Do you have any sevens?”). Any other player holding cards with that value must hand them over. If nobody has a card with that value, then the player must “go fish” by taking a card from the stock.
- ★ The goal of the game is to make books, where a book is the complete set of all four cards that have the same value. The player with the most books at the end of the game is the winner. As soon as a player collects a book, he places it face-up on the table so all the other players can see what books everyone else has.
- ★ When a player places a book on the table, that may cause him to run out of cards. If it does, then he has to draw five more cards from the stock. If there are fewer than five cards left in the stock, he takes all of them. The game is over as soon as the stock is out of cards. The winner is then chosen based on whoever has the most books.
- ★ For this computer version of Go Fish, there are two computer players and one human player. Every round starts with the human player selecting one of the cards in his hand, which is displayed at all times. He does this by choosing one of the cards and indicating that he will ask for a card. Then the two computer players will ask for their cards. The results of each round will be displayed. This will repeat until there's a winner.
- ★ The game will take care of all of the trading of cards and pulling out of books automatically. Once there's a winner, the game is over. The game displays the name of the winner (or winners, in case of a tie). No other action can be taken—the player will have to restart the program in order to start a new game.

If you don't know what you're building before you start, then how would you know when you're done? That's why most professional software projects start with a specification that tells you what you're going to build.

2

Build the form

Build the form for the Go Fish! game. It should have a ListBox control for the player's hand, two TextBox controls for the progress of the game, and a button to let the player ask for a card. To play the game, the user will select one of the cards from the hand and click the button to ask the computer players if you have that card.

This TextBox control should have its Name property set to `textBoxName`. In this screenshot, it's disabled, but it should be enabled when the program starts.

Set this button's Name property to `buttonStart`. It's disabled in this screenshot, but it starts out enabled. It'll get disabled once the game is started.

These are TextBox controls named `textProgress` and `textBooks`.

Set the `ReadOnly` property of the two TextBox controls to `True`—that will make them read-only text boxes.

The player's current hand is displayed in a ListBox control called `listHand`. You can set its name using the Name property.

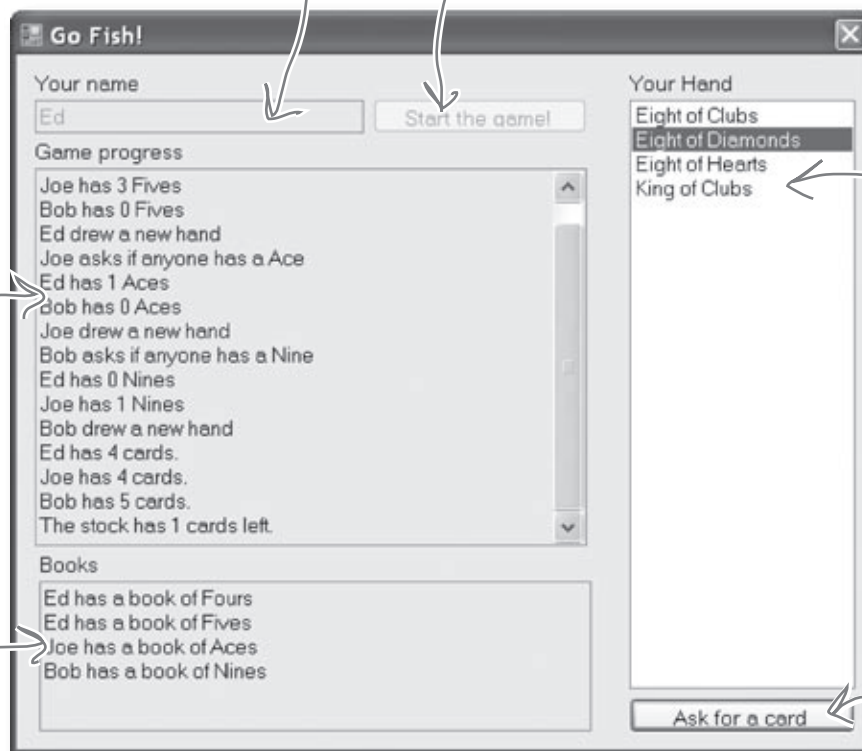

Set this button's Name property to `buttonAsk`, and set its `Enabled` property to `False`. That will disable it, which means it can't be pressed. The form will enable it as soon as the game starts.

→ We're not done yet—flip the page!



LONG EXERCISE (CONTINUED)

3 Here's the code for the form

Enter it exactly like you see here. The rest of the code that you write yourself will have to work with it.

```
public partial class Form1 : Form {
    public Form1() {
        InitializeComponent();
    }

    private Game game;

    private void buttonStart_Click(object sender, EventArgs e) {
        if (String.IsNullOrEmpty(textName.Text)) {
            MessageBox.Show("Please enter your name", "Can't start the game yet");
            return;
        }
        game = new Game(textName.Text, new string[] { "Joe", "Bob" }, textProgress);
        buttonStart.Enabled = false;
        textName.Enabled = false;
        buttonAsk.Enabled = true;
        UpdateForm();
    }

    private void UpdateForm() {
        listHand.Items.Clear();
        foreach (String cardName in game.GetPlayerCardNames())
            listHand.Items.Add(cardName);
        textBooks.Text = game.DescribeBooks();
        textProgress.Text += game.DescribePlayerHands();
        textProgress.SelectionStart = textProgress.Text.Length;
        textProgress.ScrollToCaret();
    }

    private void buttonAsk_Click(object sender, EventArgs e) {
        textProgress.Text = "";
        if (listHand.SelectedIndex < 0) {
            MessageBox.Show("Please select a card");
            return;
        }
        if (game.PlayOneRound(listHand.SelectedIndex)) {
            textProgress.Text += "The winner is... " + game.GetWinnerName();
            textBooks.Text = game.DescribeBooks();
            buttonAsk.Enabled = false;
        } else
            UpdateForm();
    }
}
```

This is the only class that the form interacts with. It runs the whole game.

The Enabled property enables or disables a control on the form.

When you start a new game, it creates a new instance of the Game class, enables the "Ask" button, disables the "Start Game" button, and then redraws the form.

This method clears and repopulates the ListBox that holds the player's hand, and then updates the text boxes.

Using SelectionStart and ScrollToCaret() like this scrolls the textbox to the end, so if there's too much text to display at once it scrolls down to the bottom.

The SelectionStart line moves the flashing textbox cursor to the end, and once it's moved, the ScrollToCaret() method scrolls the text box down to the cursor.

The player selects one of the cards and clicks the "Ask" button to see if any of the other players have a card that matches its value. The Game class plays a round using the PlayOneRound() method.

4

You'll need this code, too

You'll need the code you wrote before for the `Card` class, the `Deck` class and the `CardComparer_byValue` class. But you'll need to add a few more methods to the `Deck` class... and you'll need to understand them in order to use them.

```
public Card Peek(int cardNumber) {
    return cards[cardNumber];
}

public Card Deal() {
    return Deal(0);
}

public bool ContainsValue(Card.Values value) {
    foreach (Card card in cards)
        if (card.Value == value)
            return true;
    return false;
}

public Deck PullOutValues(Card.Values value) {
    Deck deckToReturn = new Deck(new Card[] { });
    for (int i = cards.Count - 1; i >= 0; i--)
        if (cards[i].Value == value)
            deckToReturn.Add(Deal(i));
    return deckToReturn;
}

public bool HasBook(Card.Values value) {
    int NumberOfCards = 0;
    foreach (Card card in cards)
        if (card.Value == value)
            NumberOfCards++;
    if (NumberOfCards == 4)
        return true;
    else
        return false;
}

public void SortByValue() {
    cards.Sort(new CardComparer_byValue());
}
```

The `Peek()` method lets you take a peek at one of the cards in the deck without dealing it.

Someone overloaded `Deal()` to make it a little easier to read. If you don't it pass any parameters, it deals a card off the top of the deck.

The `ContainsValue()` method searches through the entire deck for cards with a certain value, and returns true if it finds any. Can you guess how you'll use this in the Go Fish game?

You'll use the `PullOutValues()` method when you build the code to get a book of cards from the deck. It looks for any cards that match a value, pulls them out of the deck, and returns a new deck with those cards in it.

The `HasBook()` method checks a deck to see if it contains a book of four cards of whatever value was passed as the parameter. It returns true if there's a book in the deck, false otherwise.

The `SortByValue()` method sorts the deck using the `Comparer_byValue` class.

→ **Still not done—flip the page!**



LONG EXERCISE (CONTINUED)

5

Now comes the HARD part: Build the Player class

There's an instance of the Player class for each of the three players in the game. They get created by the `buttonStart` button's event handler.

```
public class Player
{
    private string name;
    public string Name { get { return name; } }
    private Random random;
    private Deck cards;
    private TextBox textBoxOnForm;

    public Player(String name, Random random, TextBox textBoxOnForm) {
        // The constructor for the Player class initializes four private fields, and then
        // adds a line to the TextBox control on the form that says, "Joe has just
        // joined the game" - but use the name in the private field, and don't forget to
        // add line break ("\r\n") at the end of every line you add to the TextBox.
    }

    public List<Card.Values> PullOutBooks() { } // see the facing page for the code
    public Card.Values GetRandomValue() {
        // This method gets a random value—but it has to be a value that's in the deck!
    }

    public Deck DoYouHaveAny(Card.Values value) {
        // This is where an opponent asks if I have any cards of a certain value
        // use Deck.PullOutValues() to pull out the values. Add a line to the TextBox
        // that says, "Joe has 3 sixes" - use the new Card.Plural() static method
    }

    public void AskForACard(List<Player> players, int myIndex, Deck stock) {
        // Here's an overloaded version of AskForACard() - choose a random value
        // from the deck using GetRandomValue() and ask for it using AskForACard()
    }

    public void AskForACard(List<Player> players, int myIndex, Deck stock, Card.Values value) {
        // Ask the other players for a value. First add a line to the TextBox: "Joe asks
        // if anyone has a Queen". Then go through the list of players that was passed in
        // as a parameter and ask each player if he has any of the value (using his
        // DoYouHaveAny() method). He'll pass you a deck of cards - add them to my deck.
        // Keep track of how many cards were added. If there weren't any, you'll need
        // to deal yourself a card from the stock (which was also passed as a parameter),
        // and you'll have to add a line to the TextBox: "Joe had to draw from the stock"
    }

    // Here's a property and a few short methods that were already written for you
    public int CardCount { get { return cards.Count; } }
    public void TakeCard(Card card) { cards.Add(card); }
    public string[] GetCardNames() { return cards.GetCardNames(); }
    public Card Peek(int cardNumber) { return cards.Peek(cardNumber); }
    public void SortHand() { cards.SortByValue(); }
}
```

Look closely at each of the comments—they tell you what the methods are supposed to do. Your job is to fill in the methods.

That Peek() method we added to the Deck class will come in handy. It lets the program look at one of the cards in the deck by giving its index number, but unlike Deal() it doesn't remove the card.

```
public List<Card.Values> PullOutBooks() {
    List<Card.Values> Books = new List<Card.Values>();
    for (int i = 1; i <= 13; i++) {
        Card.Values value = (Card.Values)i;
        int howMany = 0;
        for (int card = 0; card < cards.Count; card++)
            if (cards.Peek(card).Value == value)
                howMany++;
        if (howMany == 4) {
            Books.Add(value);
            for (int card = cards.Count - 1; card >= 0; card--)
                cards.Deal(card);
        }
    }
    return Books;
}
```

You'll have to build TWO overloaded versions of the AskForACard() method. The first one is used by the opponents when they ask for cards—it'll look through their hands and find a card to ask for. The second one is used when the player asks for the card. Both of them ask EVERY other player (both computer and human) for any cards that match the value.

6 You'll need to add this method to the Card class

It's a static method to take a value and return its plural—that way a ten will return "Tens" but a six will return "Sixes" (with "es" on the end). Since it's static, you call it with the class name—Card.Plural()—and not from an instance.

```
public partial class Card {
    public static string Plural(Card.Values value) {
        if (value == Values.Six)
            return "Sixes";
        else
            return value.ToString() + "s";
    }
}
```

We used a partial class to add this static method to Card to make it easy for you to see what's going on. But you don't need to use a partial class—if you want, you can just add it straight into the existing Card class.

→ Nearly there—keep flipping!



LONG Exercise (CONTINUED)



The rest of the job: Build the Game class

The form keeps one instance of Game. It manages the game play. Look closely at how it's used in the form.

```
public class Game {
    private List<Player> players;
    private Dictionary<Card.Values, Player> books;
    private Deck stock;
    private TextBox textBoxOnForm;

    public Game(string playerName, string[] opponentNames, TextBox textBoxOnForm) {
        Random random = new Random();
        this.textBoxOnForm = textBoxOnForm;
        players = new List<Player>();
        players.Add(new Player(playerName, random, textBoxOnForm));
        foreach (string player in opponentNames)
            players.Add(new Player(player, random, textBoxOnForm));
        books = new Dictionary<Card.Values, Player>();
        stock = new Deck();
        Deal();
        players[0].SortHand();
    }

    private void Deal() {
        // This is where the game starts - this method's only called at the beginning
        // of the game. Shuffle the stock, deal five cards to each player, then use a
        // foreach loop to call each player's PullOutBooks() method.
    }

    public bool PlayOneRound(int selectedPlayerCard) {
        // Play one round of the game. The parameter is the card the player selected
        // from his hand - get its value. Then go through all of the players and call
        // each one's AskForACard() methods, starting with the human player (who's at
        // at index zero in the Players list - make sure he asks for the selected
        // card's value). Then call PullOutBooks() - if it returns true, then the
        // player ran out of cards and needs to draw a new hand. After all the players
        // have gone, sort the human player's hand (so it looks nice in the form).
        // Then check the stock to see if it's out of cards. If it is, reset the
        // TextBox on the form to say, "The stock is out of cards. Game over!" and return
        // true. Otherwise, the game isn't over yet, so return false.
    }

    public bool PullOutBooks(Player player) {
        // Pull out a player's books. Return true if the player ran out of cards, otherwise
        // return false. Each book is added to the Books dictionary. A player runs out of
        // cards when he's used all of his cards to make books—and he wins the game.
    }

    public string DescribeBooks() {
        // Return a long string that describes everyone's books by looking at the Books
        // dictionary: "Joe has a book of sixes. (line break) Ed has a book of Aces."
    }
}
```

```

public string GetWinnerName() {
    // This method is called at the end of the game. It uses its own dictionary
    // (Dictionary<string, int> winners) to keep track of how many books each player
    // ended up with in the books dictionary. First it uses a foreach loop
    // on books.Keys -- foreach (Card.Values value in books.Keys) -- to populate
    // its winners dictionary with the number of books each player ended up with.
    // Then it loops through that dictionary to find the largest number of books
    // any winner has. And finally it makes one last pass through winners to come
    // up with a list of winners in a string ("Joe and Ed"). If there's one winner,
    // it returns a string like this: "Ed with 3 books". Otherwise it returns a
    // string like this: "A tie between Joe and Bob with 2 books."
}

// Here are a couple of short methods that were already written for you:

public string[] GetPlayerCardNames() {
    return players[0].GetCardNames();
}

public string DescribePlayerHands() {
    string description = "";
    for (int i = 0; i < players.Count; i++) {
        description += players[i].Name + " has " + players[i].CardCount;
        if (players[i].CardCount == 1)
            description += " card.\r\n";
        else
            description += " cards.\r\n";
    }
    description += "The stock has " + stock.Count + " cards left.";
    return description;
}

```

Here's a hint for writing the `GetWinnerName()` method: You'll need to create a new `Dictionary<string, int>` called `winners` at the top of the method. The `winners` dictionary will let you use each player's name to look up the number of books he made during the game. First you'll use a `foreach` loop to go through the books that the players made and build the dictionary. Then you'll use another `foreach` loop to find the highest number of books associated with any player. But there might be a tie—more than one player might have the most books! So you'll need one more `foreach` loop to look for all the players in `winners` that have the number of books that you found in the second loop and build a string that says who won.



Here are the filled-in methods in the Game class.

```

public class Game {
    private void Deal() {
        stock.Shuffle();
        for (int i = 0; i < 5; i++)
            foreach (Player player in players)
                player.TakeCard(stock.Deal());
        foreach (Player player in players)
            PullOutBooks(player);
    }

    public bool PlayOneRound(int selectedPlayerCard) {
        Card.Values cardToAskFor = players[0].Peek(selectedPlayerCard).Value;
        for (int i = 0; i < players.Count; i++) {
            if (i == 0)
                players[0].AskForACard(players, 0, stock, cardToAskFor);
            else
                players[i].AskForACard(players, i, stock);
            if (PullOutBooks(players[i])) {
                textBoxOnForm.Text += players[i].Name + " drew a new hand\r\n";
                int card = 1;
                while (card <= 5 && stock.Count > 0) {
                    players[i].TakeCard(stock.Deal());
                    card++;
                }
                players[0].SortHand();
                if (stock.Count == 0) {
                    textBoxOnForm.Text = "The stock is out of cards. Game over!\r\n";
                    return true;
                }
            }
        }
        return false;
    }

    public bool PullOutBooks(Player player)
    {
        List<Card.Values> BooksPulled = player.PullOutBooks();
        foreach (Card.Values value in BooksPulled)
            books.Add(value, player);
        if (player.CardCount == 0)
            return true;
        return false;
    }
}

```

The Deal() method gets called when the game first starts—it shuffles the deck and then deals five cards to each player. Then it pulls out any books that the players happened to have been dealt.

After the player or opponent asks for a card, the game pulls out any books that he made. If a player's out of books, he draws a new hand by dealing up to 5 cards from the stock.

As soon as the player clicks the "Ask for a card" button, the game calls AskForACard() with that card. Then it calls AskForACard() for each opponent.

After the round is played, the game sorts the player's hand, to make sure it's displayed in order on the form. Then it checks to see if the game's over. If it is, PlayOneRound() returns true.

PullOutBooks() looks through a player's cards to see if he's got four cards with the same value. If he does, they get added to his books dictionary. And if he's got no cards left afterwards, it returns true.

```

public string DescribeBooks() {
    string whoHasWhichBooks = "";
    foreach (Card.Values value in books.Keys)
        whoHasWhichBooks += books[value].Name + " has a book of "
            + Card.Plural(value) + "\r\n";
    return whoHasWhichBooks;
}

public string GetWinnerName() {
    Dictionary<string, int> winners = new Dictionary<string, int>();
    foreach (Card.Values value in books.Keys) {
        string name = books[value].Name;
        if (winners.ContainsKey(name))
            winners[name]++;
        else
            winners.Add(name, 1);
    }
    int mostBooks = 0;
    foreach (string name in winners.Keys)
        if (winners[name] > mostBooks)
            mostBooks = winners[name];
    bool tie = false;
    string winnerList = "";
    foreach (string name in winners.Keys)
        if (winners[name] == mostBooks)
        {
            if (!String.IsNullOrEmpty(winnerList))
            {
                winnerList += " and ";
                tie = true;
            }
            winnerList += name;
        }
    winnerList += " with " + mostBooks + " books";
    if (tie)
        return "A tie between " + winnerList;
    else
        return winnerList;
}
}

```

The form needs to display a list of books, so it uses `DescribeTheBooks()` to turn the player's books dictionary into words.

Once the last card's been picked up, the game needs to figure out who won. That's what the `GetWinnerName()` does. And it'll use a dictionary called `winners` to do it. Each player's name is a key in the dictionary; its value is the number of books that player got during the game.

Next the game looks through the dictionary to figure the number of books that the player with the most books has. It puts that value in a variable called `mostBooks`.

Now that we know which player has the most books, the method can come up with a string that lists the winner (or winners).

—————→ We're not done yet—flip the page!



LONG Exercise SOLUTION (CONTINUED)

Here are the filled-in methods in the Player class.

```

public Player(String name, Random random, TextBox textBoxOnForm) {
    this.name = name;
    this.random = random;
    this.textBoxOnForm = textBoxOnForm;
    this.cards = new Deck( new Card[] {} );
    textBoxOnForm.Text += name + " has just joined the game\r\n";
}

public Card.Values GetRandomValue() {
    Card randomCard = cards.Peek(random.Next(cards.Count));
    return randomCard.Value;
}

public Deck DoYouHaveAny(Card.Values value) {
    Deck cardsIHave = cards.PullOutValues(value);
    textBoxOnForm.Text += Name + " has " + cardsIHave.Count + " "
        + Card.Plural(value) + "\r\n";
    return cardsIHave;
}

public void AskForACard(List<Player> players, int myIndex, Deck stock) {
    Card.Values randomValue = GetRandomValue();
    AskForACard(players, myIndex, stock, randomValue);
}

public void AskForACard(List<Player> players, int myIndex,
    Deck stock, Card.Values value) {
    textBoxOnForm.Text += Name + " asks if anyone has a " + value + "\r\n";
    int totalCardsGiven = 0;
    for (int i = 0; i < players.Count; i++) {
        if (i != myIndex) {
            Player player = players[i];
            Deck CardsGiven = player.DoYouHaveAny(value);
            totalCardsGiven += CardsGiven.Count;
            while (CardsGiven.Count > 0)
                cards.Add(CardsGiven.Deal());
        }
    }
    if (totalCardsGiven == 0) {
        textBoxOnForm.Text += Name + " must draw from the stock.\r\n";
        cards.Add(stock.Deal());
    }
}

```

Here's the constructor for the Player class. It sets its private fields and the adds a line to the progress text box saying who joined.

The GetRandomValue() method uses Peek() to look at a random card in the player's hand.

DoYouHaveAny() uses the PullOutValues() method to pull out and return all cards that match the parameter.

There are two overloaded AskForACard() methods. This one is used by the opponents—it gets a random card from the hand and calls the other AskForACard().

This AskForACard() method looks through every player (except for the one asking), calls its DoYouHaveAny() method, and adds any cards handed over to the hand.

If no cards were handed over, the player has to draw from the stock using its Deal() method.

And yet MORE collection types...

List and Dictionary objects are two of the **built-in generic collections** that are part of the .NET framework. Lists and dictionaries are very flexible—you can access any of the data in them in any order. But sometimes you need to restrict how your program works with the data because the *thing* that you're representing inside your program works like that in the real world. For situations like that, you'll use a **Queue** or a **Stack**. Those are the other two generic collections that are similar to lists, but they're especially good at making sure that your data is processed in a certain order.

There are other types of collections, too—but these are the ones that you're most likely to come in contact with.

Use a Queue when the first object you store will be the first one you'll use, like:

- ★ Cars moving down a one-way street
- ★ People standing in line
- ★ Customers on hold for a customer service support line
- ★ Anything else that's handled on a first-come, first-served basis

A queue is first-in first-out, which means that the first object that you put into the queue is the first one you pull out of it to use.

Use a Stack when you always want to use the object you stored most recently, like:

- ★ Furniture loaded into the back of a moving truck
- ★ A stack of books where you want to read the most recently added one first
- ★ A pyramid of cheerleaders, where the ones on top have to dismount first... imagine the mess if the one on the bottom walked away first!

The stack is first-in last-out—the first object that goes into the stack is the last one that comes out of it.

Generic collections are an important part of the .NET framework

They're really useful—so much that the IDE automatically adds this statement to the top of every class you add to your project:

```
using System.Collections.Generic;
```

Almost every large project that you'll work on will include some sort of generic collection, because your programs need to store data. And when you're dealing with groups of similar things in the real world, they almost always naturally fall into a category that corresponds pretty well to one of these kinds collections.

You can, however, use `foreach` to enumerate through a stack or queue, because they implement `IEnumerable`!

A queue is like a list that lets you put objects on the end of the list and use the ones on the front. A stack only lets you access the last object you put into it.

A queue is FIFO — First In, First Out

A **queue** is a lot like a list, except that you can't just add or remove items at any index. To add an object to a queue, you **enqueue** it. That adds the object to the end of the queue. You can **dequeue** the first object from the front of the queue. When you do that, the object is removed from the queue, and the rest of the objects in the queue move up a position.

```
Queue<string> myQueue = new Queue<string>();
myQueue.Enqueue("first in line");
myQueue.Enqueue("second in line");
myQueue.Enqueue("third in line");
myQueue.Enqueue("last in line");
string takeALook = myQueue.Peek();①
string getFirst = myQueue.Dequeue();②
string getNext = myQueue.Dequeue();③
int howMany = myQueue.Count;④
myQueue.Clear();
MessageBox.Show("Peek() returned: " + takeALook + "\n"
+ "The first Dequeue() returned: " + getFirst + "\n"
+ "The second Dequeue() returned: " + getNext + "\n"
+ "Count before Clear() was " + howMany + "\n"
+ "Count after Clear() is now " + myQueue.Count);⑤
```

Create a new queue of strings.

Here's where we add four items to the queue. When we pull them out of the queue, they'll come out in the same order they went in.

Peek() lets you take a "look" at the first item in the queue without removing it.

The first Dequeue() pulls the first item out of the queue. Then the second one shifts up into the first place—the next call to Dequeue() pulls that one out next.

The Clear() method removes all objects from the queue.

The queue's Count property returns the number of items in the queue.



Objects in a queue need to wait their turn. The first one in the queue is the first one to come out of it.

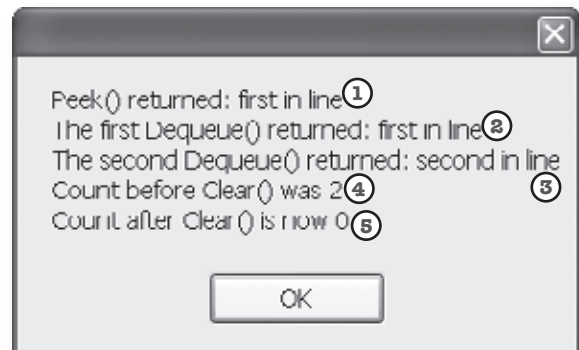

A stack is LIFO — Last In, First Out

A **stack** is really similar to a queue—with one big difference. You **push** each item onto a stack, and when you want to take an item from the stack you **pop** one of it. When you pop an item off of a stack, you end up with the most recent item that you pushed onto it. It's just like a stack of plates, magazines or anything else—you can drop something onto the top of the stack, but you need to take it off before you can get to whatever's underneath it.

Creating a stack is just like creating any other generic collection.

When you push an item onto a stack, it pushes the other items back one notch and sits on top.

```
Stack<string> myStack = new Stack<string>();
myStack.Push("first in line");
myStack.Push("second in line");
myStack.Push("third in line");
myStack.Push("last in line");
1 string takeALook = myStack.Peek();
2 string getFirst = myStack.Pop();
3 string getNext = myStack.Pop();
4 int howMany = myStack.Count;
myStack.Clear();
MessageBox.Show("Peek() returned: " + takeALook + "\n"
+ "The first Pop() returned: " + getFirst + "\n"
+ "The second Pop() returned: " + getNext + "\n"
+ "Count before Clear() was " + howMany + "\n"
+ "Count after Clear() is now " + myStack.Count);
```

When you pop an item off the stack, you get the most recent item that was added.

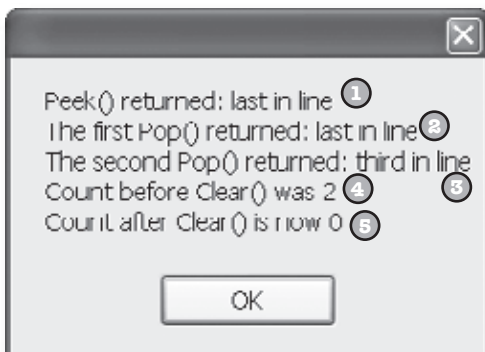

The last object you put on a stack is the first object that you pull off of it.





Wait a minute, something's bugging me. You haven't shown me anything I can do with a stack or a queue that I can't do with a list—they just save me a couple of lines of code. But I can't get at the items in the middle of a stack or a queue. I can do that with a list pretty easily! So why would I give that up just for a little convenience?

Don't worry—you don't give up anything when you use a queue or a stack.

It's really easy to convert a `Queue` object to a `List` object. And it's just as easy to convert a `List` to a `Queue`, a `Queue` to a `Stack`... in fact, you can create a `List`, `Queue` or `Stack` from any other object that implements the `IEnumerable` interface. All you have to do is use the overloaded constructor that lets you pass the collection you want to copy from as a parameter. That means you have the flexibility and convenience of representing your data with the collection that best matches the way you need to be used.

Let's set up a stack with four items—in this case, a stack of strings.

```
Stack<string> myStack = new Stack<string>();
myStack.Push("first in line");
myStack.Push("second in line");
myStack.Push("third in line");
myStack.Push("last in line");

Queue<string> myQueue = new Queue<string>(myStack);
List<string> myList = new List<string>(myQueue);
Stack<string> anotherStack = new Stack<string>(myList);
MessageBox.Show("myQueue has " + myQueue.Count + " items\n"
    + "myList has " + myList.Count + " items\n"
    + "anotherStack has " + anotherStack.Count + " items\n");
```

It's easy to convert that stack to a queue, then copy the queue to a list, and then copy the list to another stack.

All four items were copied into the new collections.

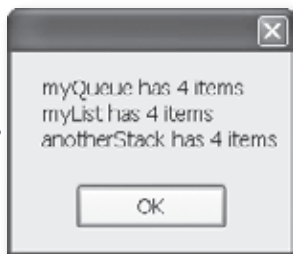

...and you can always use a `foreach` loop to access all of the members in a stack or a queue!



Exercise

Write a program to help a cafeteria full of lumberjacks eat some flapjacks. Start with the Lumberjack class, filling in the missing code. Then design the form, and add the button event handlers to it.

- 1 Here's the Lumberjack class. Fill in the get accessor for FlapjackCount and the TakeFlapjacks and EatFlapjacks methods.

```
public class Lumberjack {
    private string name;
    public string Name { get { return name; } }
    private Stack<Flapjack> meal;
    public Lumberjack(string name) {
        this.name = name;
        meal = new Stack<Flapjack>();
    }
    public int FlapjackCount { get { // return the count } }
    public void TakeFlapjacks(Flapjack Food, int HowMany) {
        // Add some number of flapjacks to the Meal stack
    }
    public void EatFlapjacks() {
        // Write this output to the console
    }
}
```

```
public enum Flapjack {
    crispy,
    soggy,
    browned,
    banana
}
```

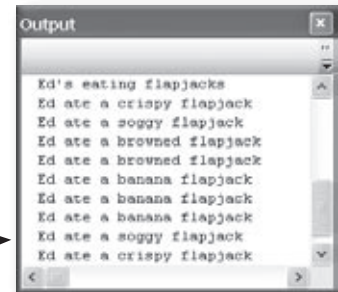

- 2 Build this form. It lets you enter the names of lumberjacks into a text box so they get in the breakfast line. You can give the lumberjack at the front of the line a plate of flapjacks, and then tell him to move on to eat them using the "Next lumberjack" button. We've given you the click event handler for the "Add flapjacks" button. Use a queue called **breakfastLine** to keep track of the lumberjacks.

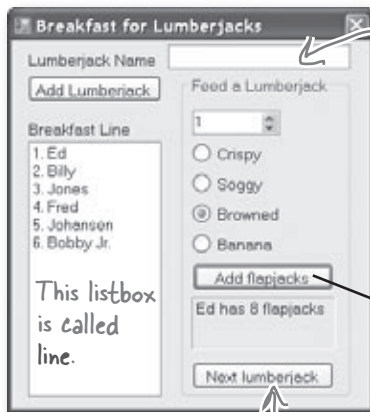

When the user clicks "Add Lumberjack", add the name in the name text box to the BreakfastLine queue.

When you drag these RadioButton controls into the groupbox, the form automatically links them and only allows the user to check one of them at a time. Look at the addFlapjacks_Click method to figure out what they should be named.

```
private void addFlapjacks_Click(...) {
    Flapjack food;
    if (crispy.Checked == true)
        food = Flapjack.crispy;
    else if (soggy.Checked == true)
        food = Flapjack.soggy;
    else if (browned.Checked == true)
        food = Flapjack.browned;
    else
        food = Flapjack.banana;
```

Note the special "else if" syntax.

Peek() returns a reference to the first lumberjack in the queue.

```
Lumberjack currentLumberjack = breakfastLine.Peek();
currentLumberjack.TakeFlapjacks(food,
    (int)howMany.Value);
```

RedrawList(); The NumericUpDown control is called howMany, and the label is called nextInLine.

This button should dequeue the next lumberjack, call his EatFlapjacks method, and then redraw the listbox.

You'll need to add a RedrawList() method to update the listbox with the contents of the queue. All three buttons will call it. Here's a hint: it uses a foreach loop.



Exercise Solution

```

private Queue<Lumberjack> breakfastLine = new Queue<Lumberjack>();
private void addLumberjack_Click(object sender, EventArgs e) {
    breakfastLine.Enqueue(new Lumberjack(name.Text));
    name.Text = "";
    RedrawList();
}
private void RedrawList() {
    int number = 1;
    line.Items.Clear();
    foreach (Lumberjack lumberjack in breakfastLine) {
        line.Items.Add(number + ". " + lumberjack.Name);
        number++;
    }
    if (breakfastLine.Count == 0) {
        groupBox1.Enabled = false;
        nextInLine.Text = "";
    } else {
        groupBox1.Enabled = true;
        Lumberjack currentLumberjack = breakfastLine.Peek();
        nextInLine.Text = currentLumberjack.Name + " has "
            + currentLumberjack.FlapjackCount + " flapjacks";
    }
}
private void nextLumberjack_Click(object sender, EventArgs e) {
    Lumberjack nextLumberjack = breakfastLine.Dequeue();
    nextLumberjack.EatFlapjacks();
    nextInLine.Text = "";
    RedrawList();
}

public class Lumberjack {
    private string name;
    public string Name { get { return name; } }
    private Stack<Flapjack> meal;

    public Lumberjack(string name) {
        this.name = name;
        meal = new Stack<Flapjack>();
    }

    public int FlapjackCount { get { return meal.Count; } }

    public void TakeFlapjacks(Flapjack food, int howMany) {
        for (int i = 0; i < howMany; i++) {
            meal.Push(food);
        }
    }

    public void EatFlapjacks() {
        Console.WriteLine(name + "'s eating flapjacks");
        while (meal.Count > 0) {
            Console.WriteLine(name + " ate a "
                + meal.Pop().ToString() + " flapjack");
        }
    }
}

```

The RedrawList() method uses a foreach loop to pull the lumberjacks out of their queue and add each of them to the listbox.

We called the listbox "line", the label between the two buttons "nextInLine".

This if statement updates the label with information about the first lumberjack in the queue.

The TakeFlapjacks method updates the Meal stack.

The EatFlapjacks method uses a while loop to print out the lumberjack's meal.



Collectioncross

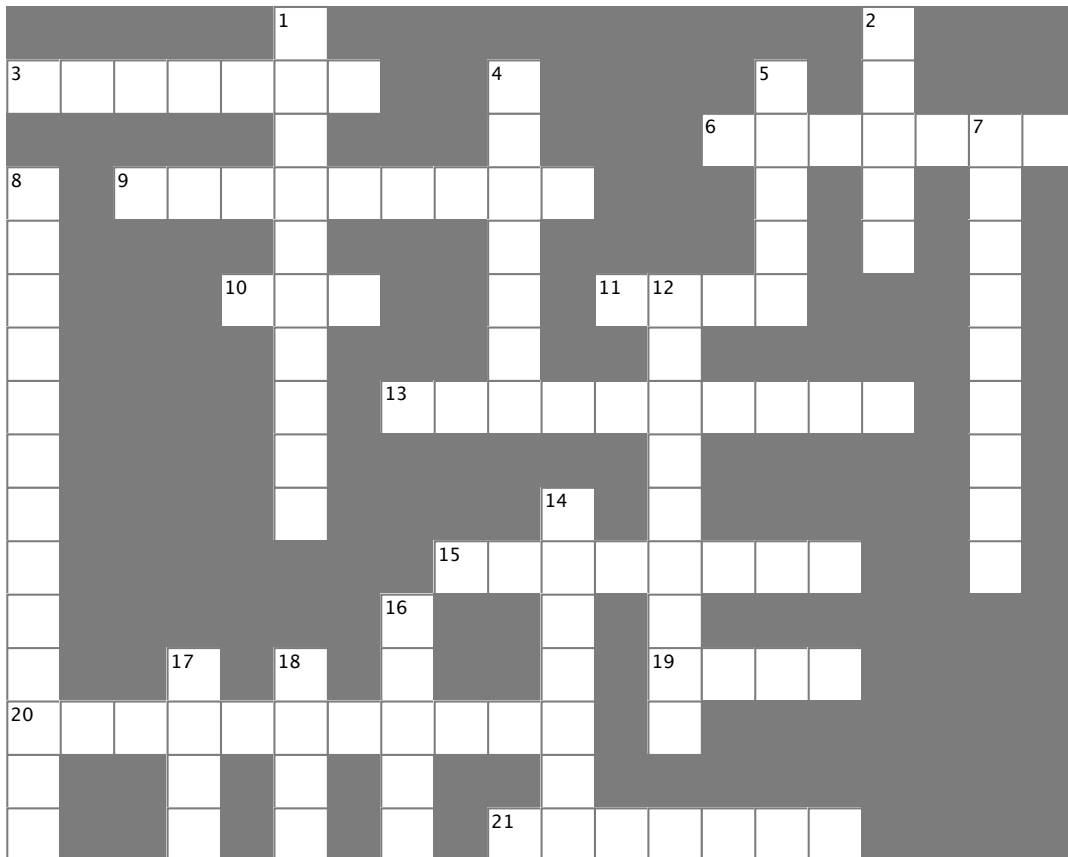

Across

3. An instance of a _____ collection only works with one specific type
6. A special kind of loop that only works on collections
9. The name of the method you use to send a string to the output
10. How you remove something from a stack
11. An object that's like an array but more flexible
13. Two methods in a class with the same name but different parameters are...
15. A method to figure out if a certain object is in a collection
19. An easy way to keep track of categories
20. All generic collections implement this interface
21. How you remove something from a queue

Down

1. The generic collection that lets you map keys to values
2. This collection is first-in, first-out
4. The built-in class that lets your program write text to the output
5. A method to find out how many things are in a collection
7. The only method in the Comparable interface
8. Most professional projects start with this
12. An object that implements this interface helps your list sort its contents
14. How you add something to a queue
16. This collection is first-in, last-out
17. How you add something to a stack
18. This method returns the next object to come off of a stack or queue

Name:

Date:

C# Lab

The Quest

This lab gives you a spec that describes a program for you to build, using the knowledge you've gained over the last few chapters.

This project is bigger than the ones you've seen so far. So read the whole thing before you get started, and give yourself a little time. And don't worry if you get stuck—there's nothing new in here, so you can move on in the book and come back to the lab later.

We've filled in a few design details for you, and we've made sure you've got all the pieces you need... and nothing else.

It's up to you to finish the job. You can download an executable for this lab from the website... but we won't give you the code for the answer.

The spec: build an adventure game

Your job is to build an adventure game where a mighty adventurer is on a quest to defeat level after level of deadly enemies. You'll build a **turn-based system**, which means the player makes one move and then the enemies make one move. The player can move **or** attack, and then each enemy gets a chance to move **and** attack. The game keeps going until the player either defeats all the enemies on all seven levels or dies.

The enemies get a bit of an advantage—they move every turn, and after they move they'll attack the player if he's in range.

The game window gives an overhead view of the dungeon where the player fights his enemies.

The player can pick up weapons and potions along the way.

The player and enemies move around in the dungeon.

The player moves using the four Move buttons.

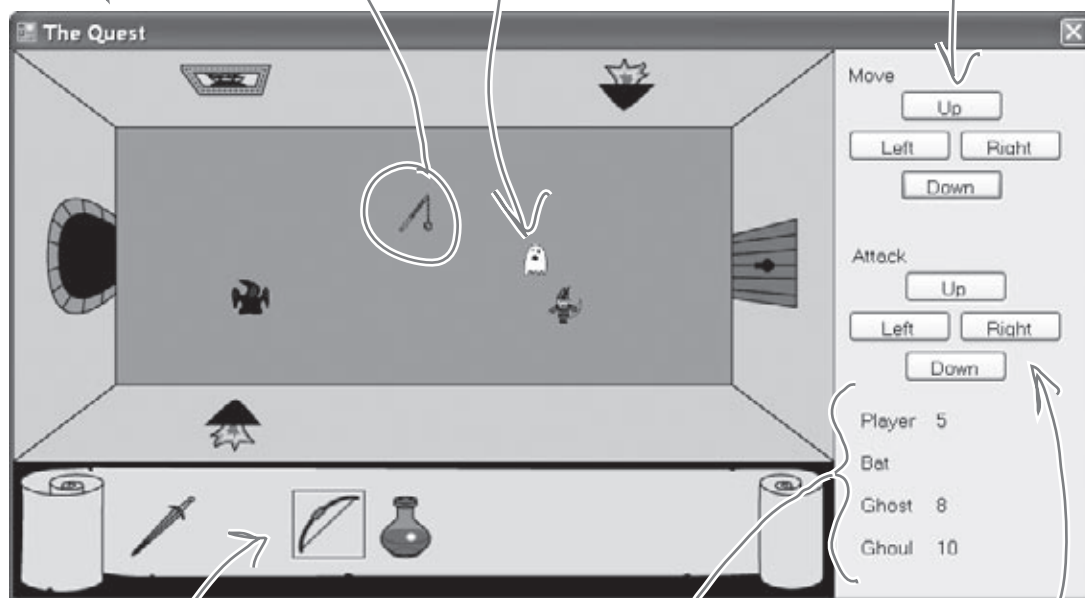

Here's the player's inventory. It shows what items the player's picked up, and draws a box around the item that they're currently using. The player clicks on an item to equip it, and uses the Attack button to use the item.

The game shows you the number of hit points for the player and enemies. When the player attacks an enemy, the enemy's hit points go down. Once the hit points get down to zero, the enemy or player dies.

These four buttons are used to attack enemies and drink potions.

The player picks up weapons...

There are weapons and potions scattered around the dungeon that the player can pick up and use to defeat his enemies. All he has to do is move onto a weapon and it disappears from the floor and appears in his inventory.

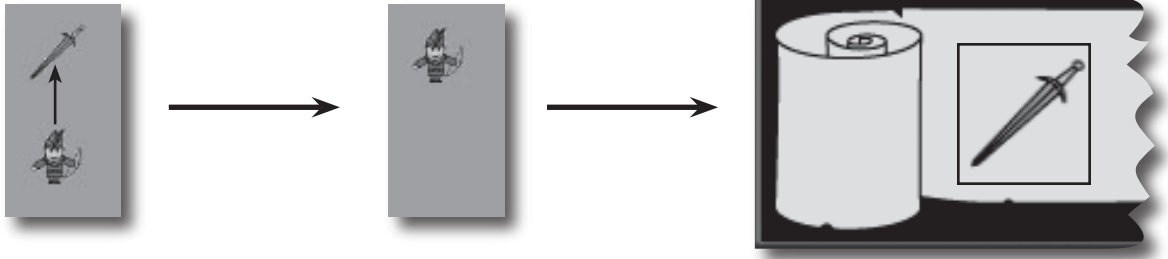

...and attacks enemies with them

Every level in the game has a weapon that the player can pick up and use to defeat his enemies. Once the weapon's picked up, it should disappear from the game floor.

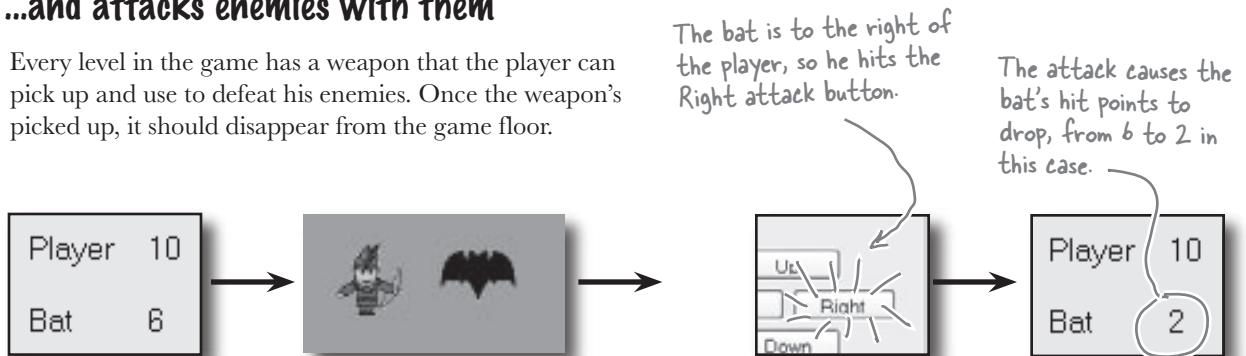

Higher levels bring more enemies

There are three different kinds of enemies: a bat, a ghost, and a ghoul. The first level only has a bat. The seventh level is the last one, and it has all three enemies.

The bat flies around somewhat randomly. When it's near the player, it causes a small amount of damage.



The ghost moves slowly towards the player. As soon as it's close to the player, it attacks and causes a medium amount of damage.



A ghoul moves quickly towards the player, and causes heavy damage when it attacks.



The design: building the form

The form gives the game its unique look. Use the form's `BackgroundImage` property to display the image of the dungeon and the inventory, and a series of `PictureBox` controls to show the player, weapons and enemies in the dungeon. You'll use a `TableLayoutPanel` control to display the hit points for the player, bat, ghost and ghouls as well as the buttons for moving and attacking.

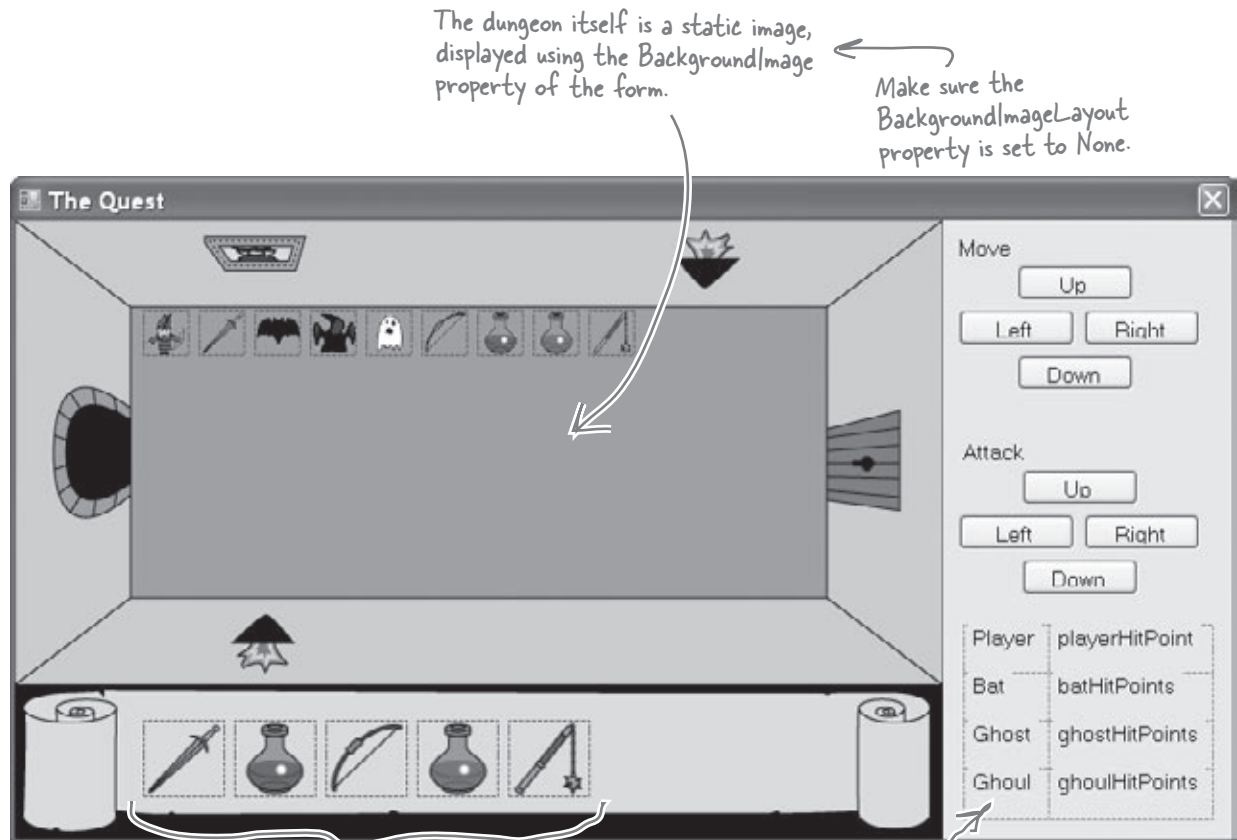

The dungeon itself is a static image, displayed using the `BackgroundImage` property of the form.

Make sure the `BackgroundImageLayout` property is set to `None`.

Each of these icons is a `PictureBox`.

Hit points, movement buttons, and attack buttons are all displayed in a `TableLayoutPanel`.

Download the background image and the graphics for the weapons, enemies, and player from the Head First Labs website: www.headfirstlabs.com/books/hfcsharp

Everything in the dungeon is a PictureBox

Players, weapons, and enemies should all be represented by icons. Add nine PictureBox controls, and set their Visible properties to False. Then, your game can move around the controls, and toggle their Visible properties as needed.



You can set a PictureBox's BackColor property to Color.Transparent to let the form's background picture or color show through any transparent pixels in the picture.

Add nine PictureBox controls to the dungeon. Use the Size property to make each one 30x30. It doesn't matter where you place them—the form will move them around. Use the little black arrow that shows up when you click on the PictureBox to set each to one of the images from the Head First Labs web site.

After you've added the nine PictureBox controls, right-click on the player's icon and select "Bring to Front", then send the three weapon icons to back. That ensures player icons stay "above" any items that are picked up.

Controls overlap each other in the IDE, so the form needs to know which ones are in front, and which are in back. That's what the "Bring to Front" and "Send to Back" form designer commands do.

The inventory contains PictureBox controls, too

You can represent the inventory of the player as five 50x50 PictureBox controls. Set the BackColor property of each to **Color.Transparent** (if you use the Properties window to set the property, just type it into the BackColor row). Since the picture files have a transparent background, you'll see the scroll and dungeon behind them:

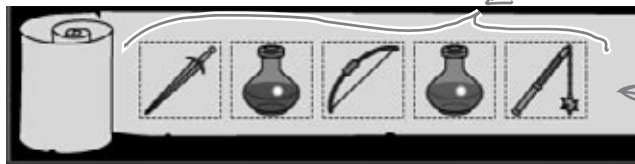

You'll need five more 50x50 PictureBoxes for the inventory.

When the player equips one of the weapons, the form should set the BorderStyle of that weapon icon to FixedSingle and the rest of the icons' BorderStyle to None.

Build your stats window

The hit points are in a TableLayoutPanel, just like the attack and movement buttons. For the hit points, create two columns in the panel, and drag the column divider to the left a bit. Add four rows, each 25% height, and add in Label controls to each of the eight cells:

2 columns, 4 rows...
8 cells for your hit
point statistics.

Player	playerHitPoint
Bat	batHitPoints
Ghost	ghostHitPoints
Ghoul	ghoulHitPoints

Each cell has a Label in it, and you can update those values during the game.

The architecture: using the objects

You'll need several types of objects in your game: a `Player` object, several sub-types of an `Enemy` object, and several sub-types of a `Weapon` object. And you'll also need one object to keep up with everything that's going on: the `Game` object.

This is just the general overview. We'll give you a lot more details on how the player and enemies move, how the enemy figures out if it's near the player, etc.

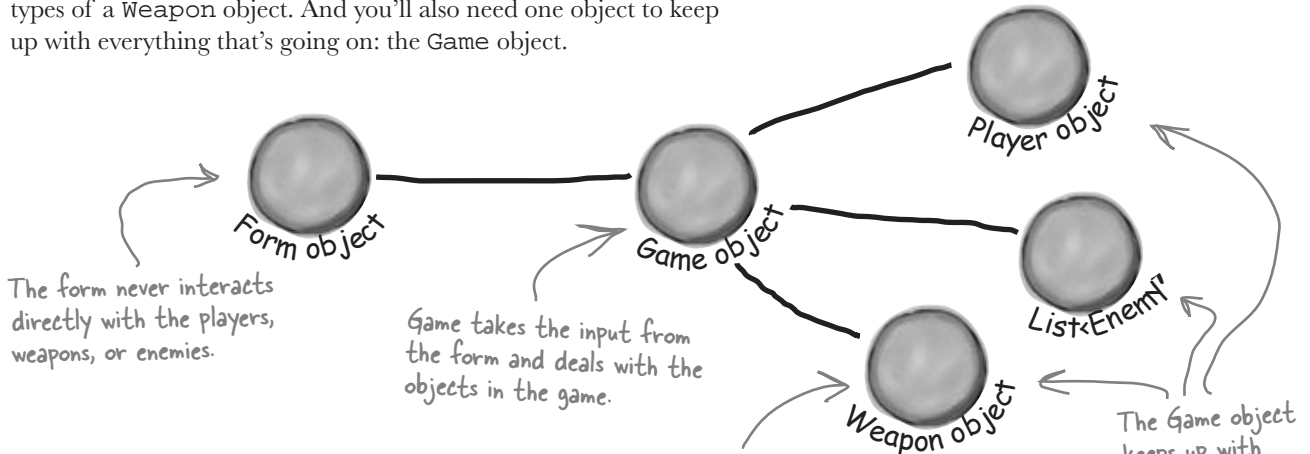

The Game object handles turns

When one of your form's `Move` buttons is clicked, the form will call the `Game` object's `Move()` method. That method will let the player take a turn, and then let all the enemies move. So it's up to `Game` to handle the turn-based movement portion of the game.

There's only one weapon per level, so the game just needs a `Weapon` reference, not a `List`. The `Player`, however, has a `List<Weapon>` to hold the inventory.

For example, here's how the move buttons work:

We left the parameters out of this diagram. Each `Move()` method takes a direction, and some of them take a `Random` object too.

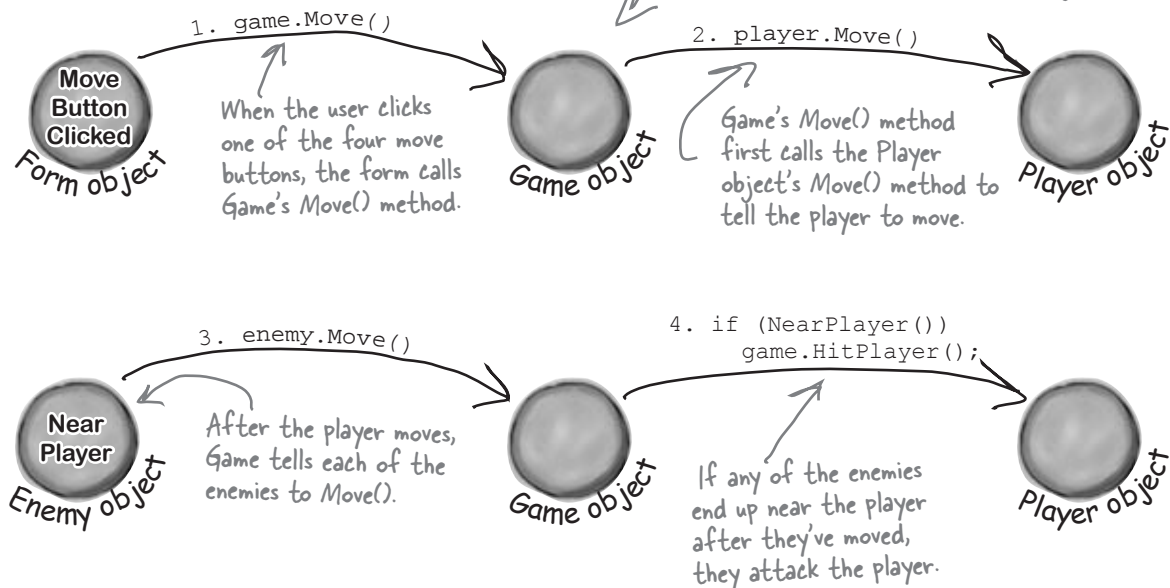

The form delegates activity to the Game object

Movement, attacking, and inventory all begin in the form. So clicking a movement or attack button, or an item in inventory, triggers code in your form. But it's the Game object that controls the objects in the game. So the form has to pass on anything that happens to the Game object, and then the Game object takes it from there:

How moving works

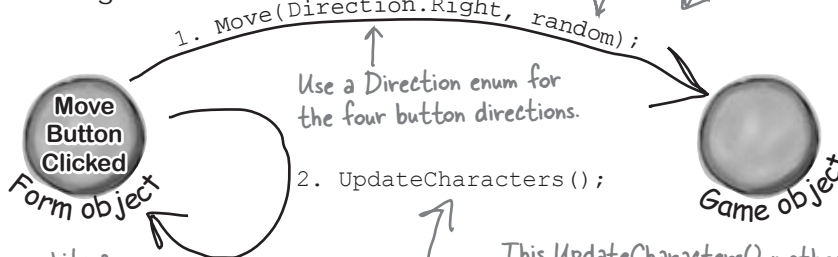

`Game.Move()` calls the enemies' `Move()` methods, which all take a random reference.

Use a `Direction` enum for the four button directions.

The Form object calls the game's `Move()`, and then calls its own `UpdateCharacters()` method to update the screen.

Game handles updating locations, so when `UpdateCharacters()` is called, things are moved to their new locations.

When the player hits an enemy, it causes a random amount of damage (up to a maximum damage limit).

How attacking works

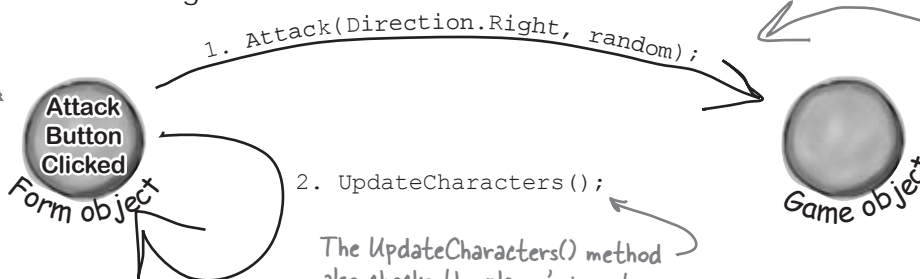

This `UpdateCharacters()` method is part of the form. It reads the location of the player, enemies, and any weapons currently in the dungeon and moves the `PictureBoxes` to match them.

Attacking is like movement... the form calls `Attack()` on Game, and Game handles dealing with the attack.

The `UpdateCharacters()` method also checks the player's inventory and makes sure the correct icons are displayed on the inventory scroll.

The inventory scroll displays all of the icons for the items that the player's picked up.

How the inventory scroll works

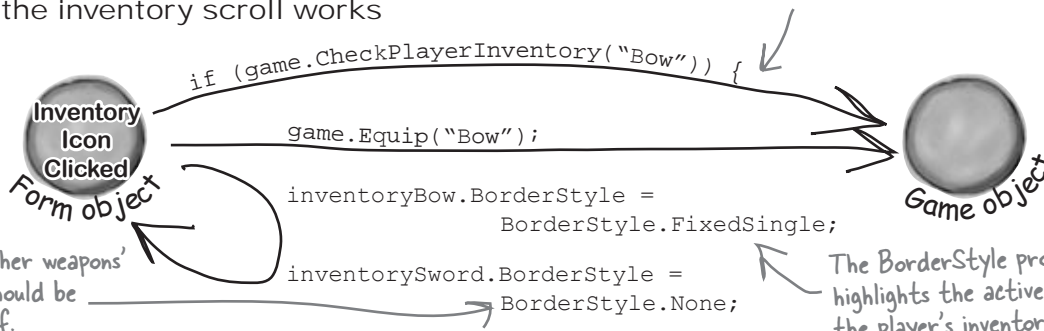

All the other weapons' borders should be turned off.

The `BorderStyle` property highlights the active item in the player's inventory.

Building the Game class

We've gotten you started with the Game class in the code below. There's a lot for you to do—so read through this code carefully, get it into the IDE, and get ready to go to work:

```
using System.Drawing;
public class Game {
    public List<Enemy> Enemies;
    public Weapon WeaponInRoom;
    private Player player;
    public Point PlayerLocation { get { return player.Location; } }
    public int PlayerHitPoints { get { return player.HitPoints; } }
    public List<string> PlayerWeapons { get { return player.Weapons; } }
    private int level = 0;
    public int Level { get { return level; } }
    private Rectangle boundaries;
    public Rectangle Boundaries { get { return boundaries; } }
    public Game(Rectangle boundaries) {
        this.boundaries = boundaries;
        player = new Player(this,
            new Point(boundaries.Left + 10, boundaries.Top + 70));
    }
    public void Move(Direction direction, Random random) {
        player.Move(direction);
        foreach (Enemy enemy in Enemies)
            enemy.Move(random);
    }
    public void Equip(string weaponName) {
        player.Equip(weaponName);
    }
    public bool CheckPlayerInventory(string weaponName) {
        return player.Weapons.Contains(weaponName);
    }
    public void HitPlayer(int maxDamage, Random random) {
        player.Hit(maxDamage, random);
    }
}
```

← You'll need Rectangle and Point from System.Drawing, so be sure to add this to the top of your class.

} These are okay as public properties if Enemy and Weapon are well-encapsulated... in other words, just make sure the form can't do anything inappropriate with them.

← The game keeps a private Player object. The form will only interact with this through methods on Game, rather than directly.

← The Rectangle object has a Top, Bottom, Left, and Right field, and works perfectly for the overall game area.

← Game starts out with a bounding box for the dungeon, and creates a new Player object in the dungeon.

} Movement is simple: move the player in the direction the form gives us, and move each enemy in a random direction.

← These are all great examples of encapsulation... Game doesn't know how Player handles these actions, it just passes on the needed information and lets Player do the rest.

```

public void IncreasePlayerHealth(int health, Random random) {
    player.IncreaseHealth(health, random);
}

public void Attack(Direction direction, Random random) {
    player.Attack(direction, random);
    foreach (Enemy enemy in Enemies)
        enemy.Move(random);
}

private Point GetRandomLocation(Random random) {
    return new Point(boundaries.Left +
        random.Next(boundaries.Right / 10 - boundaries.Left / 10) * 10,
        boundaries.Top +
        random.Next(boundaries.Bottom / 10 - boundaries.Top / 10) * 10);
}

public void NewLevel(Random random) {
    level++;
    switch (level) {
        case 1:
            Enemies = new List<Enemy>();
            Enemies.Add(new Bat(this, GetRandomLocation(random)));
            WeaponInRoom = new Sword(this, GetRandomLocation(random));
            break;
    }
}

```

Attack() is almost exactly like Move().
The player attacks, and the enemies all get a turn to move.

GetRandomLocation() will come in handy in the NewLevel() method, which will use it to determine where to place enemies and weapons.

This is just a math trick to get a random location within the rectangle that represents the dungeon area.

We only added the case for the level 1. It's your job to add cases for the other levels.

We've only got room in the inventory for one blue potion and one red potion. So if the player already has a red potion, then the game shouldn't add a red potion to the level (and the same goes for the blue potion).

Finish the rest of the levels

It's your job to finish the NewLevel() method. Here's the breakdown for each level:

Level	Enemies	Weapons
2	Ghost	Blue potion
3	Ghoul	Bow
4	Bat, Ghost	Bow, if not picked up on 3; otherwise, blue potion
5	Bat, Ghoul	Red potion
6	Ghost, Ghoul	Mace
7	Bat, Ghost, Ghoul	Mace, if not picked up on 6; otherwise, red potion
8	N/A	N/A - end the game with Application.Exit()

So if the blue potion is still in the player's inventory from Level 2, nothing appears on this level.

This only appears if the red potion from Level 5 has already been used up.

Finding common behavior: movement

You already know that duplicate code is bad, and duplicate code usually shows up when two or more objects share the same behavior. That's the case in the dungeon game, too... both enemies and players move.

Let's create a `Mover` class, to abstract that common behavior into a single place. `Player` and `Enemy` will inherit from `Mover`. And even though weapons don't move around, they inherit from `Mover` too, because they need some of its properties and methods. `Mover` has a `Move()` method for moving around, and a read-only `Location` property that the form can use to position a subclass of `Mover`.

We added return values and parameters to this class diagram to make it easier for you to see what's going on.

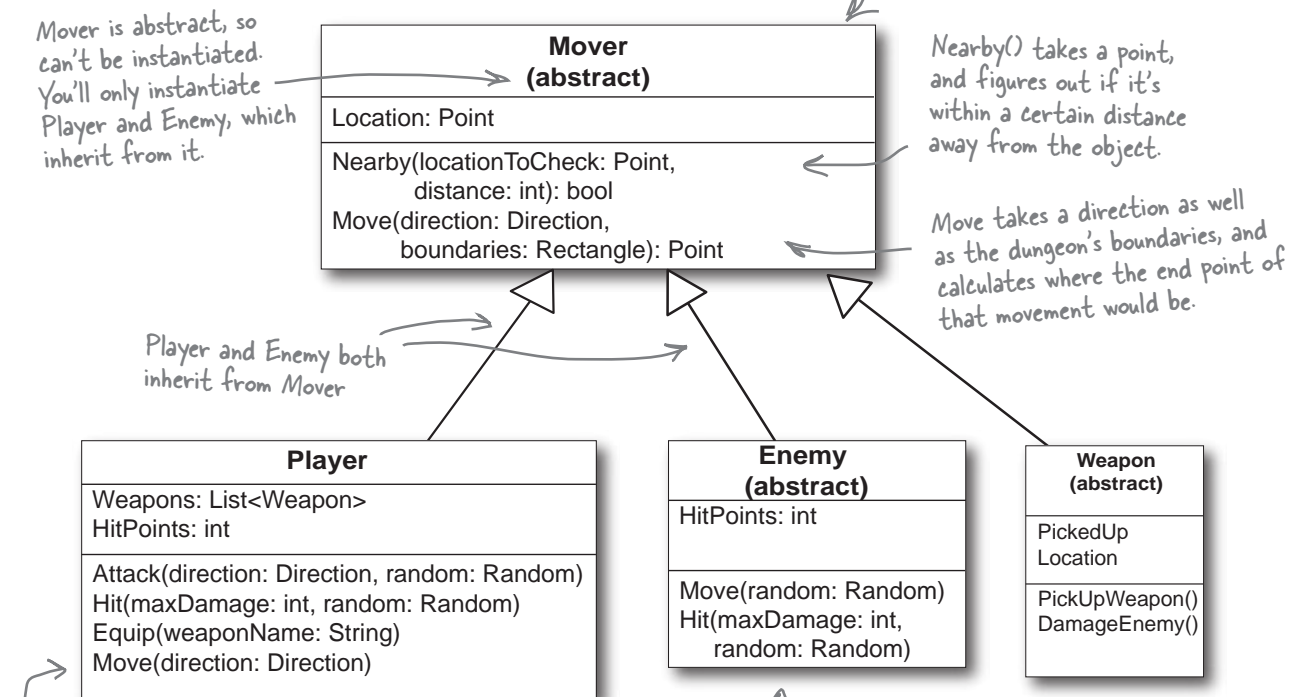

Add a Direction enum

The `Mover` class, as well as several other classes, need a `Direction` enum. Create this enum, and give it four enumerated values: `Up`, `Down`, `Left`, and `Right`.

The Mover class source code

Here's the code for Mover:

```
public abstract class Mover {
    private const int MoveInterval = 10;
    protected Point location;
    public Point Location { get { return location; } }
    protected Game game;

    public Mover(Game game, Point location) {
        this.game = game;
        this.location = location;
    }
}
```

Since protected properties are only available to subclasses, the form object can't set the location... only read it through the public get method we define.

Instances of Mover take in the Game object and a current location.

```
public bool Nearby(Point locationToCheck, int distance) {
    if (Math.Abs(location.X - locationToCheck.X) < distance &&
        (Math.Abs(location.Y - locationToCheck.Y) < distance)) {
        return true;
    } else {
        return false;
    }
}
```

The Nearby method checks a Point against this object's current location. If they're within distance of each other, then it returns true, otherwise it returns false.

```
public Point Move(Direction direction, Rectangle boundaries) {
    Point newLocation = location;
    switch (direction) {
        case Direction.Up:
            if (newLocation.Y - MoveInterval >= boundaries.Top)
                newLocation.Y -= MoveInterval;
            break;
        case Direction.Down:
            if (newLocation.Y + MoveInterval <= boundaries.Bottom)
                newLocation.Y += MoveInterval;
            break;
        case Direction.Left:
            if (newLocation.X - MoveInterval >= boundaries.Left)
                newLocation.X -= MoveInterval;
            break;
        case Direction.Right:
            if (newLocation.X + MoveInterval <= boundaries.Right)
                newLocation.X += MoveInterval;
            break;
        default: break;
    }
    return newLocation;
}
```

The Move() method tries to move one step in a direction. If it can, it returns the new Point. If it hits a boundary, it returns the original Point.

If the end location is outside the boundaries, the new location stays the same as the starting point.

Finally, this new location is returned (which might still be the same as the starting location!).

The Player class keeps track of the player

Here's a start on the Player class. Start with this code in the IDE, and then get ready to add to it.

The Player and Enemy objects need to stay inside the dungeon, which means they need to know the boundaries of the playing area. Use the Contains() method of the boundaries Rectangle to make sure they don't move out of bounds.

```
public class Player : Mover {
    private Weapon equippedWeapon;
    private int hitPoints;
    public int HitPoints { get { return hitPoints; } }

    private List<Weapon> inventory = new List<Weapon>();
    public List<string> Weapons {
        get {
            List<string> names = new List<string>();
            foreach (Weapon weapon in inventory)
                names.Add(weapon.Name);
            return names;
        }
    }

    public Player(Game game, Point location);
        : base(game, location) {
        hitPoints = 10;

    public void Hit(int maxDamage, Random random) {
        hitPoints -= random.Next(1, maxDamage);
    }

    public void IncreaseHealth(int health, Random random) {
        hitPoints += random.Next(1, health);
    }

    public void Equip(string weaponName) {
        foreach (Weapon weapon in inventory) {
            if (weapon.Name == weaponName)
                equippedWeapon = weapon;
        }
    }
}
```

All of the properties of Player are hidden from direct access.

A Player can hold multiple weapons in inventory, but can only equip one at a time.

Player inherits from Mover, so this passes in the Game and location to that base class.

The player's constructor sets its hitPoints to 10 and then calls the base class constructor.

When an enemy hits the player, it causes a random amount of damage. And when a potion increases the player's health, it increases it by a random amount.

The Equip() method tells the player to equip one of his weapons. The Game object calls this method when one of the inventory icons is clicked.

A Player object can only have one Weapon object equipped at a time.

Even though potions help the player rather than hurt the enemy, they're still considered weapons by the game. That way the inventory can be a List<Weapon>, and the game can point to one with its WeaponInRoom reference.

Write the Move() method for the Player

Game calls the Player's Move() method to tell a player to move in a certain direction. Move() takes in the direction to move (using the Direction enum you should have already added). Here's the start of that method:

This happens when one of the movement buttons on the form is clicked.

```
public void Move(Direction direction) {
    base.location = Move(direction, game.Boundaries);
    if (!game.WeaponInRoom.PickedUp) {
        // see if the weapon is nearby, and possibly pick it up
    }
}
```

Move is in the Mover base class.

You've got to fill in the rest of this method. Check and see if the weapon is near the player (within a single unit of distance). If so, pick up the weapon and add it to the player's inventory.

When the player picks up a weapon, it needs to disappear from the dungeon and appear in the inventory.

If the weapon is the only weapon the player has, go ahead and equip it immediately. That way, the player can use it right away, on the next turn.

The Weapon and form will handle making the weapon's PictureBox invisible when the player picks it up... that's not the job of the Player class.

Add an Attack() method, too

Next up is the Attack() method. This is called when one of the form's attack buttons is clicked, and carries with it a direction (again, from the Direction enum). Here's the method signature:

The weapons all have an Attack() method that takes a Direction enum and a Random object. The player's Attack() will figure out which weapon is equipped and call its Attack().

```
public void Attack(Direction direction, Random random) {
    // Your code goes here
}
```

If the weapon is a potion, then Attack() removes it from the inventory after the player drinks it.

If the player doesn't have an equipped weapon, this method won't do anything. If the player does have an equipped weapon, this should call the weapon's Attack() method.

But potions are a special case. If a potion is used, remove it from the player's inventory, since it's not available anymore.

Potions will implement an IPotion interface (more on that in a minute), so you can use the "is" word to see if a Weapon is an implementation of IPotion.

Bats, ghosts, and ghouls inherit from the Enemy class

We'll give you another useful abstract class: `Enemy`. Each different sort of enemy has its own class that inherits from the `Enemy` class. The different kinds of enemies move in different ways, so the `Enemy` abstract class leaves the `Move` method as an abstract method—the three enemy classes will need to implement it differently, depending on how they move.

Enemy (abstract)
HitPoints: int
Move(random: Random) Hit(maxDamage: int, random: Random)

```
public abstract class Enemy : Mover {
    private const int NearPlayerDistance = 25;
    private int hitPoints;
    public int HitPoints { get { return hitPoints; } }
    public bool Dead { get {
        if (hitPoints <= 0) return true;
        else return false;
    } }
}

public Enemy(Game game, Point location, int hitPoints)
    : base(game, location) { this.hitPoints = hitPoints; }

public abstract void Move(Random random);

public void Hit(int maxDamage, Random random) {
    hitPoints -= random.Next(1, maxDamage);
}

protected bool NearPlayer() {
    return (Nearby(game.PlayerLocation,
        NearPlayerDistance));
}

protected Direction FindPlayerDirection(Point playerLocation) {
    Direction directionToMove;
    if (playerLocation.X > location.X + 10)
        directionToMove = Direction.Right;
    else if (playerLocation.X < location.X - 10)
        directionToMove = Direction.Left;
    else if (playerLocation.Y < location.Y - 10)
        directionToMove = Direction.Up;
    else
        directionToMove = Direction.Down;
    return directionToMove;
}
}
```

The form can use this read-only property to see if the enemy should be visible in the game dungeon.

Each subclass of `Enemy` implements this.

When the player attacks an enemy, it calls the enemy's `Hit()` method, which subtracts a random number from the hit points.

The `Enemy` class inherited the `Nearby()` method from `mover`, which it can use to figure out whether it's near the player.

If you feed `FindPlayerDirection()` the player's location, it'll use the base class's `location` field to figure out where the player is in relation to the enemy and return a `Direction` enum that tells you which direction the enemy needs to move in order to move towards the player.

Write the different Enemy subclasses

The three Enemy subclasses are pretty straightforward. Each enemy has a different number of starting hit points, moves differently, and does a different amount of damage when it attacks. You'll need to have each one pass a different `startingHitPoints` parameter to the `Enemy` base constructor, and you'll have to write different `Move()` methods for each subclass.

Here's an example of how one of those classes might look:

```
public class Bat : Enemy {
    public Bat(Game game, Point location)
        : base(game, location, 6)
    {
    }
    public override void Move(Random random) {
        // Your code will go here
    }
}
```

You probably won't need any constructor for these; the base class handles everything.

The bat starts with 6 hit points, so it passes 6 to the base class constructor.

Each of these subclasses the `Enemy` base class, which in turn subclasses `Mover`.

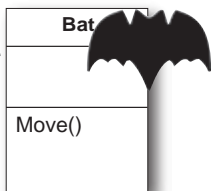

The bat flies around somewhat randomly, so it uses `Random` to fly in a random direction half the time.

Once an enemy has no more hit points, the form won't display it any more. But it'll still be in the game's `Enemies` list until the player finishes the level.

The bat starts with 6 hit points. It'll keep moving towards the player and attacking **as long as it has one or more hit points**. When it moves, there's a 50% chance that it'll move towards the player, and a 50% chance that it'll move in a random direction. After the bat moves, it checks if it's near the player—if it is, then it attacks the player with up to 2 hit points of damage.

We'll have to make sure the form sees if an enemy should be visible at every turn.

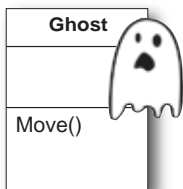

The ghost is harder to defeat than the bat, but like the bat, it will only move and attack if its hit points are greater than zero. It starts with 8 hit points. When it moves, there's a 1 in 3 chance that it'll move towards the player, and a 2 in 3 chance that it'll stand still. If it's near the player, it attacks the player with up to 3 hit points of damage.

The ghost and ghoul use `Random` to make them move more slowly than the player.

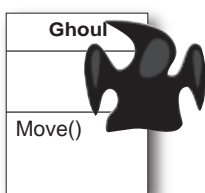

The ghoul is the toughest enemy. It starts with 10 hit points, and only moves and attacks if its hit points are greater than zero. When it moves, there's a 2 in 3 chance that it'll move towards the player, and a 1 in 3 chance that it'll stand still. If it's near the player, it attacks the player with up to 4 hit points of damage.

Weapon inherits from Mover, each weapon inherits from Weapon

We need a base Weapon class, just like we had a base Enemy class. And each weapon has a location, as well as a property indicating whether or not it's been picked up. Here's the base Weapon class:

Weapon inherits from Mover because it uses its Nearby() and Move() methods in DamageEnemy().

Weapon (abstract)
PickedUp Location
PickUpWeapon() DamageEnemy()

```
public abstract class Weapon : Mover {
    protected Game game;
    private bool pickedUp;
    public bool PickedUp { get { return pickedUp; } }
    private Point location;
    public Point Location { get { return location; } }

    public Weapon(Game game, Point location) {
        this.game = game;
        this.location = location;
        pickedUp = false;
    }
}
```

A pickedUp weapon shouldn't be displayed anymore... the form can use this get accessor to figure that out.

Every weapon has a location in the game dungeon.

The constructor sets the game and location fields, and sets pickedUp to false (because it hasn't been picked up yet).

```
public void PickUpWeapon() { pickedUp = true; }
```

Each weapon class needs to implement a Name property and an Attack() method that determines how that weapon attacks.

```
public abstract string Name { get; }
public abstract void Attack(Direction direction, Random random);
protected bool DamageEnemy(Direction direction, int radius,
                              int damage, Random random) {
    Point target = game.PlayerLocation;
    for (int distance = 0; distance < radius; distance++) {
        foreach (Enemy enemy in game.Enemies) {
            if (Nearby(enemy.Location, target, radius)) {
                enemy.Hit(damage, random);
                return true;
            }
        }
        target = Move(direction, target, game.Boundaries);
    }
    return false;
}
```

Each weapon's Name property returns its name ("Sword", "Mace", "Bow").

Each weapon has a different range and pattern of attack, so the weapons implement the Attack() method differently.

The Nearby() method in the Mover class only takes two parameters, a Point and an int, and it compares the Point to the Mover field location. You'll need to add an overloaded Nearby() that's almost identical, except that it takes three parameters, two Points and a distance, which compares the first Point to the second Point (instead of location).

The DamageEnemy() method is called by Attack(). It attempts to find an enemy in a certain direction and radius. If it does, it calls the enemy's Hit() method and returns true. If no enemy's found, it returns false.

Different weapons attack in different ways

Each subclass of Weapon has its own name and attack logistic. Your job is to implement these classes. Here's the basic skeleton for a Weapon subclass:

```
public class Sword : Weapon {
    public Sword(Game game, Point location)
        : base(game, location) { }
    public override string Name { get { return "Sword"; } }
    public override void Attack(Direction direction, Random random) {
        // Your code goes here
    }
}
```

Each subclass represents one of the three weapons: a sword, bow, or mace.

Each subclass relies on the base class to do the initialization work.

You're basically hardcoding in the name of each weapon.

The Game object will pass on the direction to attack in.

The player can use the weapons over and over—they never get dropped or used up.

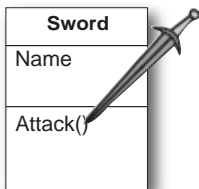

The sword is the first weapon the player picks up. It's got a wide angle of attack: if he attacks up, then it first tries to attack an enemy that's in that direction—if there's no enemy there, it looks in the direction that's clockwise from the original attack and attacks any enemy here, and if it still fails to hit then it attempts to attack an enemy counterclockwise from the original direction of attack. It's got a radius of 10, and causes 3 points of damage.

Think carefully about this... what is to the right of the direction left? What is to the left of up?

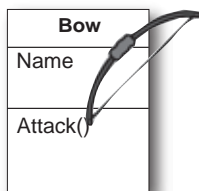

The bow has a very narrow angle of attack, but it's got a very long range—it's got an attack radius of 30, but only causes 1 point of damage. Unlike the sword, which attacks in three directions (because the player swings it in a wide arc), when the player shoots the bow in a direction, it only shoots in that one direction.

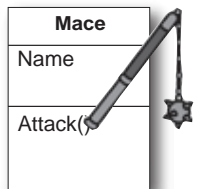

The mace is the most powerful weapon in the dungeon. It doesn't matter which direction the player attacks with it—since he swings it in a full circle, it'll attack any enemy with a radius of 20 and cause up to 6 points of damage.

The different weapons will call `DamageEnemy()` in various ways. The Mace attacks in all directions, so if the player's attacking to the right, it'll call `DamageEnemy(Direction.Right, 20, 6, random)`. If that didn't hit an enemy, it'll attack Up. If there's no enemy there, it'll try Left, then Down—that makes it swing in a full circle.

Potions implement the IPotion interface

There are two potions, a blue potion and a red potion, which increase the player's health. They act just like weapons—the player picks them up in the dungeon, equips them by clicking on the inventory, and **uses them by clicking one of the attack buttons**. So it makes sense for them to inherit from the abstract Weapon class.

But potions act a little differently, too, so you'll need to add an IPotion interface so they can have extra behavior: increasing the player's health. The IPotion interface is really simple. Potions only need to add one read-only property called Used that returns false if the player hasn't used the potion, and true if he has. The form will use it to determine whether or not to display the potion in the inventory.

```
public interface IPotion {
    bool Used { get; }
}
```

IPotion makes potions usable only once. It's also possible to find out if a Weapon is a potion with "if (weapon is IPotion) because of this interface."

The potions inherit from the Weapon class because they're used just like weapons—the player clicks on the potion in the inventory scroll to equip it, and then clicks any of the Attack buttons to use it.

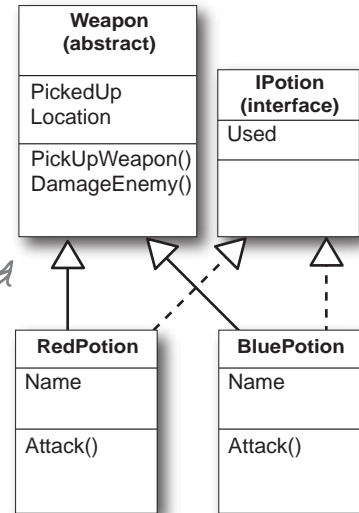

You should be able to write these classes using this class diagram and the information below.

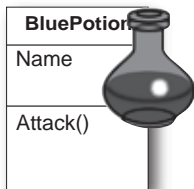

The BluePotion class's Name property should return the string "Blue Potion". Its Attack () method will be called when the player uses the blue potion—it should increase the player's health by up to 5 hit points by calling the IncreasePlayerHealth () method. After the player uses the potion, the potion's Used () method should return true.

If the player picks up a blue potion on level 2, uses it, and then picks up another one on level 4, the game will end up creating two different BluePotion instances.

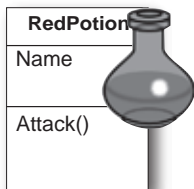

The RedPotion class is very similar to BluePotion, except that its Name property returns the string "Red Potion", and its Attack () method increases the player's health by up to 10 hit points.

The form brings it all together

There's one instance of the `Game` object, and it lives as a private field of your form. It's created in the form's `Load` event, and the various event handlers in the form use the fields and methods on the `Game` object to keep the game play going.

Everything begins with the form's `Load` event handler, which passes the `Game` a `Rectangle` that defines the boundaries of the dungeon play area. Here's some form code to get you going:

```
private Game game;
private Random random = new Random();
private void Form1_Load(object sender,
                        EventArgs e) {
    game = new Game(new Rectangle(78, 57, 420, 155));
    game.NewLevel(random);
    UpdateCharacters();
}
```

These are the boundaries of the dungeon in the background image you'll download and add to the form.

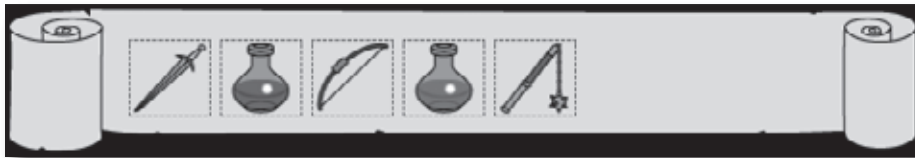

Remember to double-click on each `PictureBox` so the IDE adds a separate event handler method for each of them.

The form has a separate event handler for each of these `PictureBox`'s `Click` events. When the player clicks on the sword, it first checks to make sure the sword is in the player's inventory using the `Game` object's `CheckPlayerInventory()` method. If the player's holding the sword, the form calls `game.Equip()` to equip it. It then sets each `PictureBox`'s `BorderStyle` property to draw a box around the sword, and make sure none of the other icons have a box around them.



There's an event handler for each of the four movement buttons. They're pretty simple. First the button calls `game.Move()` with the appropriate `Direction` value, and then it calls the form's `UpdateCharacters()` method.

Make sure you change the buttons back when the player equips the sword, bow, or mace.

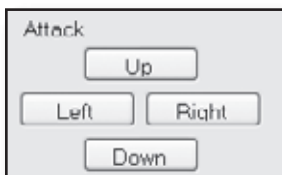

The four attack button event handlers are also really simple. Each button calls `game.Attack()`, and then calls the form's `UpdateCharacters()` method. If the player equips a potion, it's still used the same way—by calling `game.Attack()`—but potions have no direction. So make the `Left`, `Right`, and `Down` buttons invisible when the player equips a potion, and change the text on the `Up` button to say "Drink".

The form's UpdateCharacters() method moves the PictureBoxes into position

The last piece of the puzzle is the form's `UpdateCharacters()` method. Once all the objects have moved and acted on each other, the form updates everything... so weapons that been dropped have their `PictureBoxes`' Visible properties set to false, enemies and players are drawn in their new locations (and dead ones are made invisible), and inventory is updated.

Here's what you need to do:

1 Update the player's position and stats

The first thing you'll do is update the player's `PictureBox` location and the label that shows his hit points. Then you'll need a few variables to determine whether you've shown each of the various enemies.

```
public void UpdateCharacters() {
    Player.Location = game.PlayerLocation;
    playerHitPoints.Text =
        game.PlayerHitPoints.ToString();
```

```
bool showBat = false;
bool showGhost = false;
bool showGhoul = false;
int enemiesShown = 0;
// more code to go here...
```

The `showBat` variable will be set to true if we made the bat's `PictureBox` visible. Same goes for `showGhost` and `showGhoul`.

2 Update each enemy's location and hit points

Each enemy could be in a new location, and have a different set of hit points. You need to update each enemy after you've updated the player's location:

```
foreach (Enemy enemy in game.Enemies) {
    if (enemy is Bat) {
        bat.Location = enemy.Location;
        batHitPoints.Text = enemy.HitPoints.ToString();
        if (enemy.HitPoints > 0) {
            showBat = true;
            enemiesShown++;
        }
    }
}
// etc...
```

← This goes right after the code from above.

This will affect the visibility of the enemy `PictureBox` controls in just a bit.

← You'll need two more if statements like this in your foreach loop—one for the ghost and one for the ghoul.

Once you've looped through all the enemies on the level, check the `showBat` variable. If the bat was killed, then `showBat` will still be false, so make its `PictureBox` invisible and clear its hit points label. Then do the same for `showGhost` and `showGhoul`.

3 Update the weapon PictureBoxes

Declare a `weaponControl` variable and use a big `switch` statement to set it equal to the `PictureBox` that corresponds to the weapon in the room.

```

sword.Visible = false;
bow.Visible = false;
redPotion.Visible = false;
bluePotion.Visible = false;
mace.Visible = false;
Control weaponControl = null;
switch (game.WeaponInRoom.Name) {
    case "Sword":
        weaponControl = sword; break;

```

Make sure your controls' names match these names. It's easy to end up with bugs that are difficult to track down if they don't match.

You'll have more cases for each weapon type.

The rest of the cases should set the variable `weaponControl` to the correct control on the form. After the `switch`, set `weaponControl.Visible` to `true` to display it.

4 Set the Visible property on each inventory icon PictureBox

Check the `Game` object's `CheckPlayerInventory()` method to figure out whether or not to display the various inventory icons.

5 Here's the rest of the method

The rest of the method does three things. First it checks to see if the player's already picked up the weapon in the room, so it knows whether or not to display it. Then it checks to see if the player died. And finally, it checks to see if the player's defeated all of the enemies. If he has, then the player advances to the next level.

```

weaponControl.Location = game.WeaponInRoom.Location;
if (game.WeaponInRoom.PickedUp) {
    weaponControl.Visible = false;
} else {
    weaponControl.Visible = true;
}
if (game.PlayerHitPoints <= 0) {
    MessageBox.Show("You died");
    Application.Exit();
}
if (enemiesShown < 1) {
    MessageBox.Show("You have defeated the enemies on this level");
    game.NewLevel(random);
    UpdateCharacters();
}

```

Every level has one weapon. If it's been picked up, we need to make its icon invisible.

Application.Exit() immediately quits the program. It's part of System.Windows.Forms, so you'll need the appropriate using statement if you want to use it outside of a form.

If there are no more enemies on the level, then the player's defeated them all and it's time to go to the next level.

The fun's just beginning!

Seven levels, three enemies... that's a pretty decent game. But you can make it even better. Here are a few ideas to get you started...

Make the enemies smarter

Can you figure out how to change the enemies' Move() methods so that they're harder to defeat? Then see if you can change their constants to properties, and add a way to change them in the game.

Add more levels

The game doesn't have to end after seven levels. See if you can add more...can you figure out how to make the game go on indefinitely? If the player does win, make a cool ending animation with dancing ghosts and bats! And the game ends pretty abruptly if the player dies. Can you think of a more user-friendly ending? Maybe you can let the user restart the game or retry his last level.

Add different kinds of enemies

You don't need to limit the dangers to ghouls, ghosts, and bats. See if you can add more enemies to the game.

Add more weapons

The player will definitely need more help defeating any new enemies you've added. Think of new ways that the weapons can attack, or different things that potions can do. Take advantage of the fact that Weapon is a subclass of Mover—make magic weapons the player has to chase around!

Add more graphics

You can go to www.headfirstlabs.com/books/hfcsharp/ to find more graphics files for additional enemies, weapons, and other images to help spark your imagination.

This is your chance to show off! Did you come up with a cool new version of the game? Join the Head First C# forum and claim your bragging rights: www.headfirstlabs.com/books/hfcsharp/

9 reading and writing files

Save the byte array, save the world

Okay, go ahead with our shopping list ... chicken wire ... tequila ... grape jelly ... bandages ... yes, dear, I am writing this down.



Sometimes it pays to be a little persistent.

So far, all of your programs have been pretty short-lived. They fire up, run for a while, and shut down. But that's not always enough, especially when you're dealing with important information. You need to be able to **save your work**. In this chapter, we'll look at how to **write data to a file**, and then how to **read that information back in** from a file. You'll learn about the **.NET stream classes**, and also take a look at the mysteries of **hexadecimal** and **binary**.

C# uses streams to read and write data

A **stream** is the .NET Framework's way of getting data in and out of your program. Any time your C# program reads or writes a file, connects to another computer over a network, or generally does anything where it **sends or receives bytes** from one place to another, you're using streams.

Whenever you want to read data from a file or write data to a file, you'll use a Stream object.

Let's say you have a simple program—a form with an event handler that needs to read data from a file. You'll use a Stream object to do it.

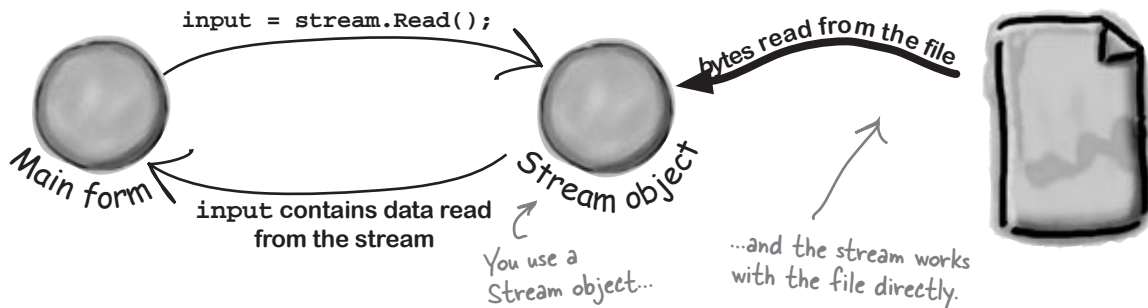

And if your program needs to write data out to the file, it can use another Stream object.

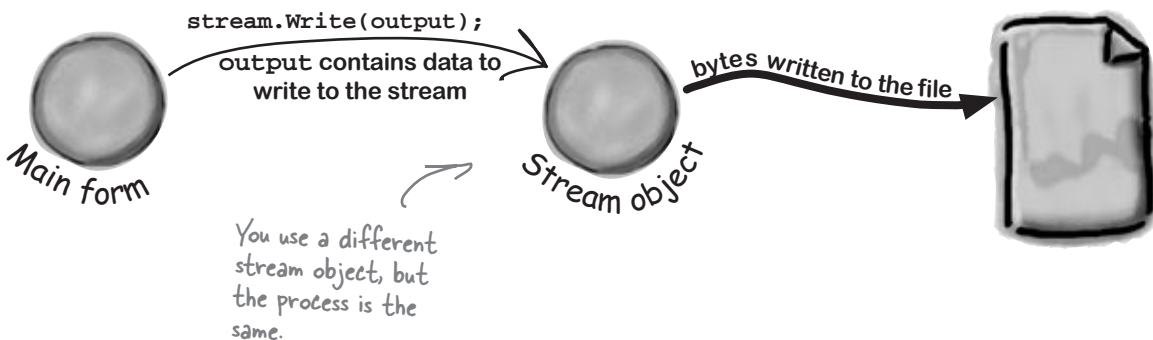

Different streams read and write different things

Every stream is a subclass of the abstract `Stream` class, and there are a bunch of built-in stream classes to do different things. We'll be concentrating on reading and writing regular files, but everything you learn in this chapter will just as easily apply to compressed or encrypted files, or network streams that don't use files at all.

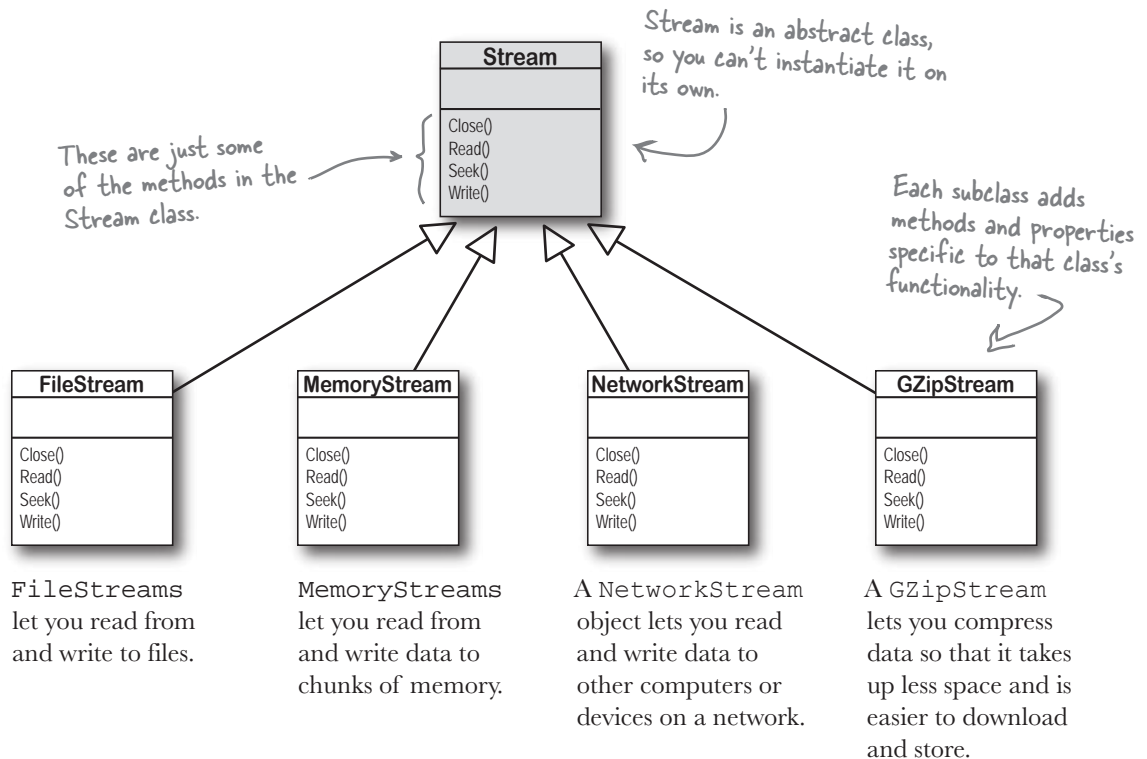

Things you can do with a stream:

- 1 **Write to the stream.**
You can write your data to a stream and through a stream's `Write()` method.
- 2 **Read from the stream.**
You can use the `Read()` method to get data from a file, or a network, or memory, or just about anything else, using a stream.
- 3 **Change your position within the stream.**
Most streams support a `Seek()` method that lets you find a position within the stream so you can insert data at a specific place.

Streams let you read and write data. Use the right kind of stream for the data you're working with.

A FileStream writes bytes to a file

When your program needs to write a few lines of text to a file, there are a lot of things that have to happen:

- 1 Create a new FileStream object and tell it to write to the file.

Make sure you add using System.IO; to any program that uses streams.



- 2 The FileStream attaches itself to a file.

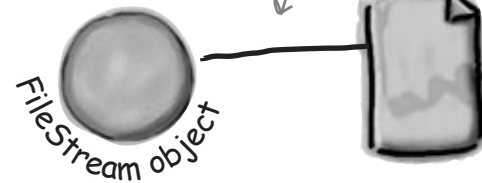

- 3 Streams write bytes to files, so you'll need to convert the string that you want to write to an array of bytes.



- 4 Call the stream's Write() method and pass it the byte array.

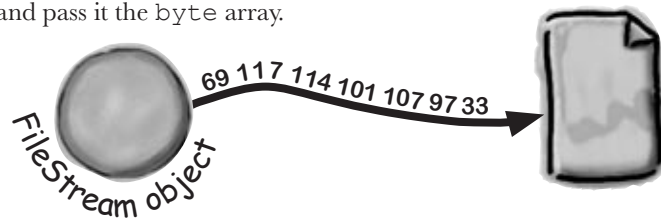

- 5 Close the file so other programs can access it.



How to write text to a file in 3 simple steps

C# comes with a convenient class called **StreamWriter** that does all of those things in one easy step. All you have to do is create a new `StreamWriter` object and give it a filename. It **automatically** creates a `FileStream` and links it to the file. Then you can use the `StreamWriter`'s `Write()` and `WriteLine()` methods to write everything to the file you want.

StreamWriter creates and manages a **FileStream** object for you automatically.

1 Use the `StreamWriter`'s constructor to open or create a file

You can pass a filename to the `StreamWriter()` constructor. When you do, the writer automatically opens the file. `StreamWriter` also has an overloaded constructor that also takes a `bool`: `true` if you want to add text to the end of an existing file (or append), or `false` if you want to delete the existing file and create a new file with the same name.

```
StreamWriter writer = new StreamWriter(@"C:\newfiles\toaster oven.txt", true);
```



Putting @ in front of the filename tells C# to treat this as a literal string, without escape characters, like `\t` for tab or `\n` for newline.

2 Use the `Write()` and `WriteLine()` methods to write to the file

These methods work just like the ones in `Console`: `Write()` writes text, and `WriteLine()` writes text and adds a line break to the end. If you include `"{0}"`, `"{1}"`, `"{2}"`, etc., inside the string you're writing, the methods include parameters in the strings being written: `"{0}"` is replaced with the first parameter after the string being written, `"{1}"` is replaced with the second, etc.

```
writer.WriteLine("The {0} is set to {1} degrees.", appliance, temp.ToString());
```



3 Call the `Close()` method to release the file

If you leave the stream open and attached to a file, then it'll keep the file locked open and no other program will be able to use it. So make sure you always close your files!

```
writer.Close();
```

The Swindler launches another diabolical plan

The citizens of Objectville have long lived in fear of the Swindler. Now he's using a `StreamWriter` to implement another evil plan. Let's take a look at what's going on:

```
StreamWriter sw = new StreamWriter(@"c:\secret_plan.txt");
sw.WriteLine("How I'll defeat Captain Amazing");
sw.WriteLine("Another genius secret plan by The Swindler");
sw.Write("I'll create an army of clones and ");
sw.WriteLine("unleash them upon the citizens of Objectville.");
string location = "the mall";
for (int number = 0; number <= 6; number++){
    sw.WriteLine("Clone #{0} attacks {1}", number, location);
    if (location == "the mall") { location = "downtown"; }
    else { location = "the mall"; }
}
sw.Close();
```

This line creates the `StreamWriter` object and tells it where the file will be.

The path starts with an `@` sign so that the `StreamWriter` doesn't interpret the `"\"` as the start of an escape sequence.

`WriteLine()` adds a new line after writing. `Write()` sends just the text, with no extra line feeds at the end.

Can you figure out what's going on with the `location` variable in this code?

You can use the `{}` within the text to pass in variables to the string being written. `{0}` is replaced by the first parameter after the string, `{1}` by the second, and so on.

`Close()` frees up any connections to the file and any resources the `StreamWriter` is using. The text doesn't get written if you don't close the stream.

This is what the code above produces.

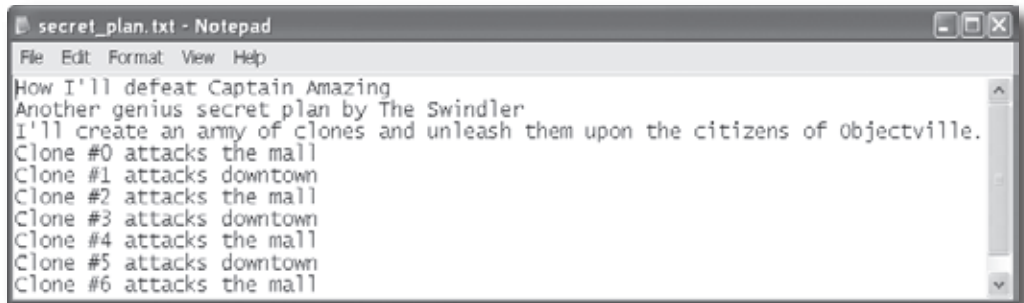



StreamWriter Magnets

Suppose you have the code for button1_Click() shown below. Your job is to use the magnets to build code for the Flobbo class so that, when the event handler is called, it produces the output shown at the bottom of the page. Good luck!

```
private void button1_Click(object sender, EventArgs e) {
    Flobbo f = new Flobbo("blue yellow");
    StreamWriter sw = f.Snobbo();
    f.Blobbo(f.Blobbo(f.Blobbo(sw), sw), sw);
}
```

```
public bool Blobbo
    (bool Already, StreamWriter sw) {
```

```
public bool Blobbo(StreamWriter sw) {
```

```
    sw.WriteLine(Zap);
    Zap = "green purple";
    return false;
```

```
return new
    StreamWriter("macaw.txt");
```

```
private string Zap;

public Flobbo(string Zap) {
    this.Zap = Zap;
}
```

```
public class Flobbo {
```

```
    if (Already) {
```

```
    } else {
```

```
public StreamWriter Snobbo() {
```

Output:

```
macaw.txt - Notepad
File Edit Format View Help
blue yellow
green purple
red orange
```



StreamWriter Magnets Solution

Your job was to construct the Flobbo class from the magnets to create the desired output.

```
private void button1_Click(object sender, EventArgs e) {
    Flobbo f = new Flobbo("blue yellow");
    StreamWriter sw = f.Snobbo();
    f.Blobbo(f.Blobbo(f.Blobbo(sw), sw), sw);
}
```

```
public class Flobbo {
```

```
    private string Zap;
```

```
    public Flobbo(string Zap) {
        this.Zap = Zap;
    }
```

```
    public StreamWriter Snobbo() {
```

```
        return new
            StreamWriter("macaw.txt");
    }
```

```
    public bool Blobbo(StreamWriter sw) {
```

```
        sw.WriteLine(Zap);
        Zap = "green purple";
        return false;
    }
```

```
    public bool Blobbo
        (bool Already, StreamWriter sw) {
```

```
        if (Already) {
```

```
            sw.WriteLine(Zap);
            sw.Close();
            return false;
```

```
        } else {
```

```
            sw.WriteLine(Zap);
            Zap = "red orange";
            return true;
```

```
        }
```

```
    }
```

The Blobbo() method is overloaded—it's got two declarations with different parameters.

Make sure you close files when you're done with them.

Output:

```
macaw.txt - Notepad
File Edit Format View Help
blue yellow
green purple
red orange
```

Reading and writing takes two objects

Let's read Swindler's secret plans with another stream, a `StreamReader`. `StreamReader` works just like a `StreamWriter`, except instead of writing a file you give the reader the name of the file to read in its constructor. The `ReadLine()` method returns a string that contains the next line from the file. You can write a loop that reads lines from it until its `EndOfStream` field is true—that's when it runs out of lines to read:

```
StreamReader reader =
    new StreamReader(@"c:\secret_plan.txt");
StreamWriter writer =
    new StreamWriter(@"e:\emailToCaptainAmazing.txt");
writer.WriteLine("To: CaptainAmazing@objectville.net");
writer.WriteLine("From: Commissioner@objectville.net");
writer.WriteLine("Subject: Can you save the day... again?");
writer.WriteLine();
writer.WriteLine("We've discovered the Swindler's plan:");
while (!reader.EndOfStream) {
    string lineFromThePlan = reader.ReadLine();
    writer.WriteLine("The plan -> " + lineFromThePlan);
}
writer.WriteLine();
writer.WriteLine("Can you help us?");
writer.Close();
reader.Close();
```

Pass the file you want to read from into the `StreamReader`'s constructor.

This program uses a `StreamReader` to read the Swindler's plan, and a `StreamWriter` to write a file that will get emailed to Captain Amazing.

An empty `WriteLine()` method writes a blank line.

`EndOfStream` is the property that tells you if there's no data left unread in the file.

This loop reads a line from the reader and writes it out to the writer.

Make sure to close every stream that you open, even if you're just reading a file.

```
emailToCaptainAmazing.txt - Notepad
File Edit Format View Help
To: CaptainAmazing@objectville.net
From: Governor@objectville.net
Subject: Can you save the day... again?

We've discovered the Swindler's plan:
The plan -> How I'll defeat Captain Amazing
The plan -> Another genius secret plan by The Swindler
The plan -> I'll create an army of clones and unleash them upon the citizens of Objectville.
The plan -> Clone #0 attacks the mall
The plan -> Clone #1 attacks downtown
The plan -> Clone #2 attacks the mall
The plan -> Clone #3 attacks downtown
The plan -> Clone #4 attacks the mall
The plan -> Clone #5 attacks downtown
The plan -> Clone #6 attacks the mall

Can you help us?
```

Data can go through more than one stream

One big advantage to working with streams in .NET is that you can have your data go through more than one stream on its way to its final destination. One of the many types of streams that .NET ships with is the `CryptoStream` class. This lets you encrypt your data before you do anything else with it:

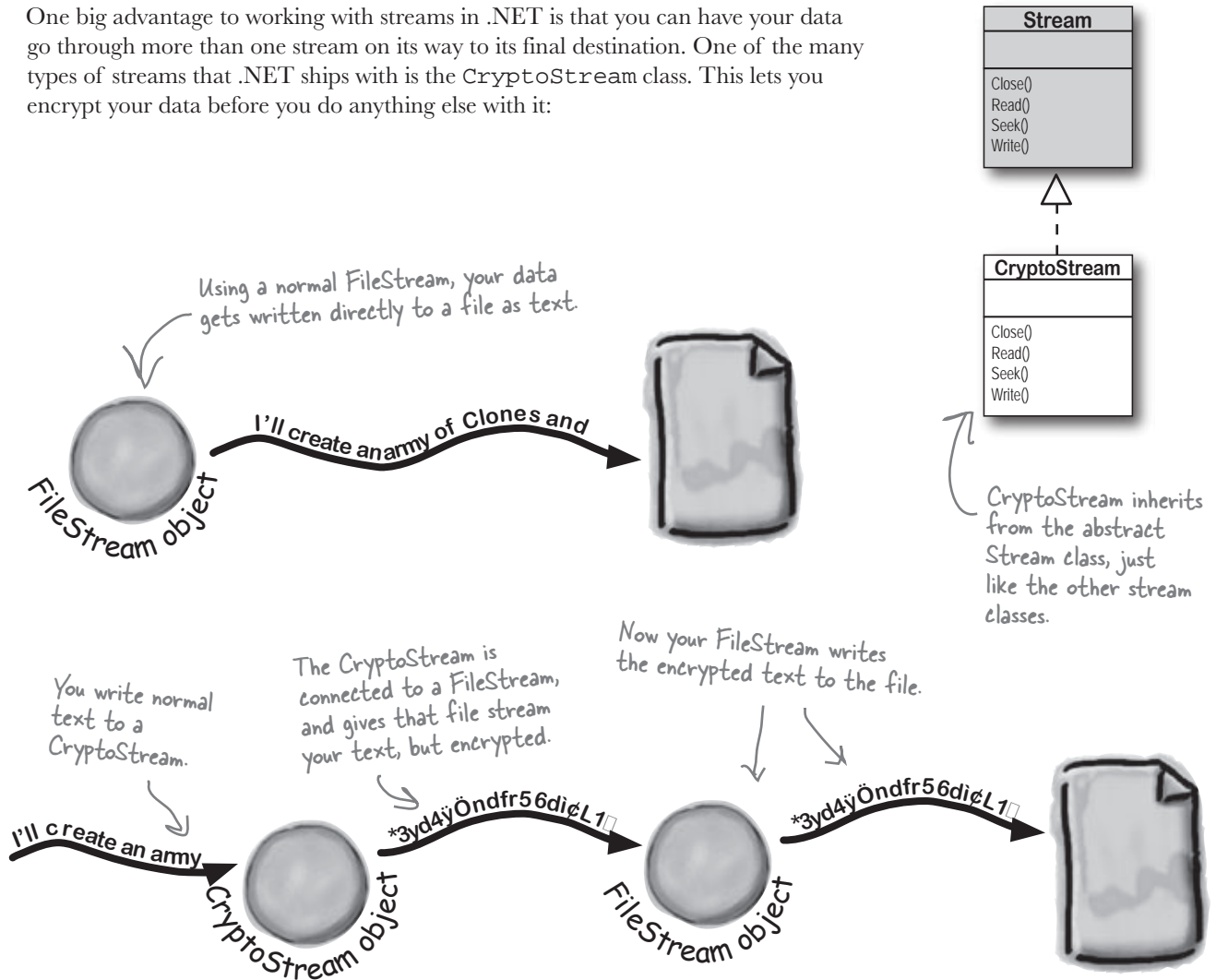

You can CHAIN streams. One stream can write to another stream, which writes to another stream... often ending with a network or file stream.

Pool Puzzle



Your **job** is to take code snippets from the pool and place them into the blank lines in the program. You can use the same snippet more than once, and you won't need to use all the snippets. Your **goal** is to make the program produce the output shown to the right.

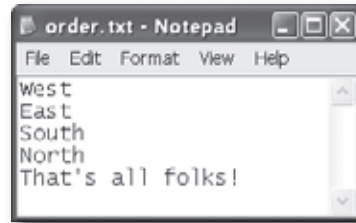

```
public class Pineapple {
    const _____ d = "delivery.txt";
    public _____
        { North, South, East, West, Flamingo }
    public static void Main() {
        _____ o = new _____("order.txt");
        Pizza pz = new Pizza(new _____(d, true));
        pz._____( Fargo.Flamingo);
        for ( _____ w = 3; w >= 0; w--) {
            Pizza i = new Pizza
                (new _____(d, false));
            i.Idaho(( Fargo)w);
            Party p = new Party(new _____(d));
            p._____(o);
        }
        o._____("That's all folks!");
        o._____( );
    }
}
```

```
public class Pizza {
    private _____ _____;
    public Pizza(_____ _____) {
        _____.Writer = Writer;
    }
    public void _____(_____. Fargo f) {
        Writer._____(f.ToString());
        Writer._____( );
    }
}

public class Party {
    private _____ Reader;
    public Party(_____ Reader) {
        _____ .Reader = Reader;
    }
    public void HowMuch(_____ q) {
        q._____(Reader._____( ));
        Reader._____( );
    }
}
```

Note: each snippet from the pool can be used more than once!

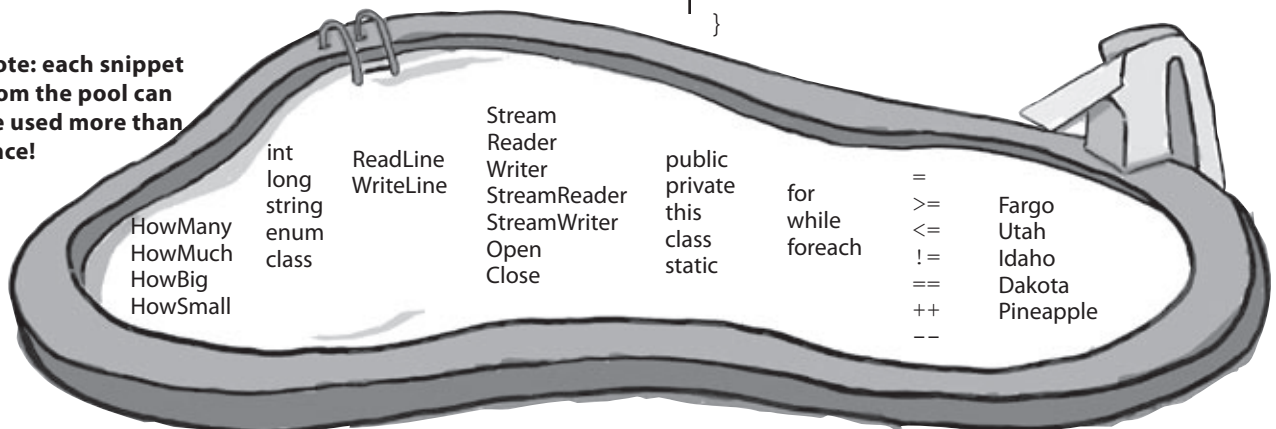

int	ReadLine	Stream	public	for	=	Fargo
long	WriteLine	Reader	private	while	>=	Utah
string		Writer	this	foreach	<=	Idaho
enum		StreamReader	class		!=	Dakota
class		StreamWriter	static		==	Pineapple
HowMany		Open			++	
HowMuch		Close			--	
HowBig						
HowSmall						



Pool Puzzle Solution

This enum is used with its ToString() method to print a lot of the output.



```
public class Pineapple {
    const string d = "delivery.txt";
    public enum Fargo { North, South, East, West, Flamingo }
    public static void Main() {
        StreamWriter o = new StreamWriter("order.txt");
        Pizza pz = new Pizza(new StreamWriter(d, true));
        pz.Idaho(Fargo.Flamingo);
        for (int w = 3; w >= 0; w--) {
            Pizza i = new Pizza(new StreamWriter(d, false));
            i.Idaho((Fargo)w);
            Party p = new Party(new StreamReader(d));
            p.HowMuch(o);
        }
        o.WriteLine("That's all folks!");
        o.Close();
    }
}
```

Here's the entry point for the program. It creates a StreamWriter that it passes to the Party class. Then it loops through the Fargo members, passing each of them to the Pizza.Idaho() method to print.



The Pizza class keeps a StreamWriter as a private field, and its Idaho() method writes Fargo enums to the file using their ToString() methods.



```
public class Pizza {
    private StreamWriter Writer;
    public Pizza(StreamWriter Writer) {
        this.Writer = Writer;
    }
    public void Idaho(Pineapple.Fargo f) {
        Writer.WriteLine(f.ToString());
        Writer.Close();
    }
}
```

The Party class has a StreamReader field, and its HowMuch() method reads a line from that StreamReader and writes it to a StreamWriter.



```
public class Party {
    private StreamReader Reader;
    public Party(StreamReader Reader) {
        this.Reader = Reader;
    }
    public void HowMuch(StreamWriter q) {
        q.WriteLine(Reader.ReadLine());
        Reader.Close();
    }
}
```

Use built-in objects to pop up standard dialog boxes

When you're working on a program that reads and writes files, there's a good chance that you'll need to pop up a dialog box at some point to prompt the user for a filename. That's why .NET ships with objects to pop up the standard Windows file dialog boxes.

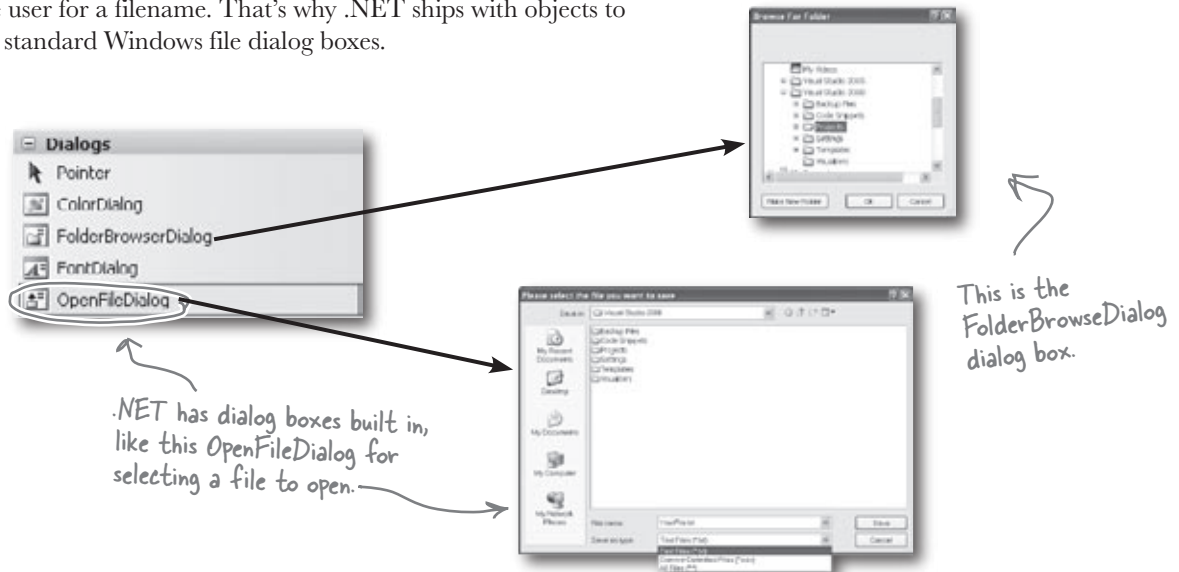

ShowDialog() pops up a dialog box

Displaying a dialog box is easy. Here's all you need to do:

- 1 Create an instance of the dialog box object. You can do this in code using `new`, or you can drag it onto your form out of the toolbox.
- 2 Set the dialog box object's properties. A few useful ones include `Title` (which sets the text in the title bar), `InitialDirectory` (which tells it which directory to open first), and `FileName` (for open and save dialog boxes).
- 3 Call the object's `ShowDialog()` method. That pops up the dialog box, and doesn't return until the user clicks the OK button or the Cancel button, or closes the window.
- 4 The `ShowDialog()` method returns a `DialogResult`, which is an enum. Some of its members are `OK` (which means the user clicked OK), `Cancel`, `Yes`, and `No` (for Yes/No dialog boxes).

We'll walk you through these steps in a minute.

Dialog boxes are just another .NET control

You can add Windows standard file dialog boxes to your program just by dragging them to your form—just drag an `OpenFileDialog` control out of the toolbox and drop it on your form. Instead of showing up as a visual control, you'll see it appear in the space below your form. That's because it's a **component**, which is a special kind of **non-visual Toolbox control** that doesn't appear directly on the form, but which you can still use in your form's code just like you use any other control.

"Non-visual" just means it doesn't appear on your form when you drag it out of the toolbox.



When you drag a component out of the Toolbox and onto your form, the IDE displays it in the space underneath the form editor.

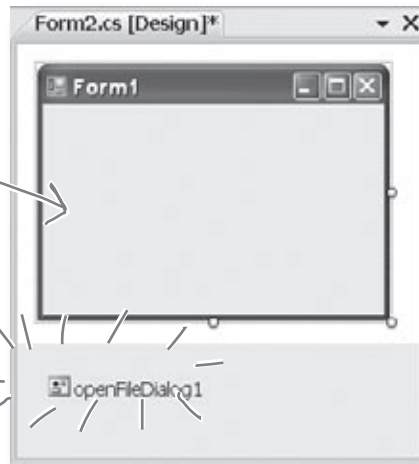

The `InitialDirectory` property changes the folder that's first displayed when the dialog opens.

```
openFileDialog1.InitialDirectory = @"c:\MyFolder\Default\";
openFileDialog1.Filter = "Text Files (*.txt)|*.txt|"
    + "Comma-Delimited Files (*.csv)|*.csv|All Files (*.*)|*.*";
openFileDialog1.FileName = "default_file.txt";
openFileDialog1.CheckFileExists = true;
openFileDialog1.CheckPathExists = false;
DialogResult result = openFileDialog1.ShowDialog();
if (result == DialogResult.OK) {
    OpenSomeFile(openFileDialog1.FileName);
}
```

The `Filter` property lets you change the filters that show up on the bottom of the dialog box, such as what types of files to show.

These properties tell the dialog box to display an error message if the user tries to open up a file or path that doesn't exist on the drive.

Display the dialog box using its `ShowDialog()` method, which returns a `DialogResult`. That's an enum that you can use to check whether or not the user hit the OK button. It'll be set to `DialogResult.OK` if the user clicked OK, and `DialogResult.Cancel` if he hit Cancel.

Dialog boxes are objects, too

An **OpenFileDialog** object shows the standard Windows “Open” window, and the **SaveFileDialog** shows its “Save” window. You can display them by creating a new instance, setting the properties on the object, and calling its `ShowDialog()` method. The `ShowDialog()` method returns a `DialogResult` enum (because some dialog boxes have more than two buttons or results, so a simple `bool` wouldn’t be enough).

```
saveFileDialog1 = new SaveFileDialog();
saveFileDialog1.InitialDirectory = @"c:\MyFolder\Default\";
saveFileDialog1.Filter = "Text Files (*.txt)|*.txt|"
    + "Comma-Delimited Files (*.csv)|*.csv|All Files (*.*)|*.*";
DialogResult result = saveFileDialog1.ShowDialog();
if (result == DialogResult.OK) {
    SaveTheFile(saveFileDialog1.FileName);
}
```

When you drag a save dialog object out of the toolbox and onto your form, the IDE just adds a line like this to your form’s `InitializeComponent()` method.

The `ShowDialog()` and `FileName` properties work exactly the same as on the `OpenFileDialog` object.

The `SaveFileDialog` object pops up the standard Windows “Save as...” dialog box.

The `Title` property lets you change this text.

The `ShowDialog()` method pops up the dialog box and opens the folder specified in the `InitialDirectory` property.

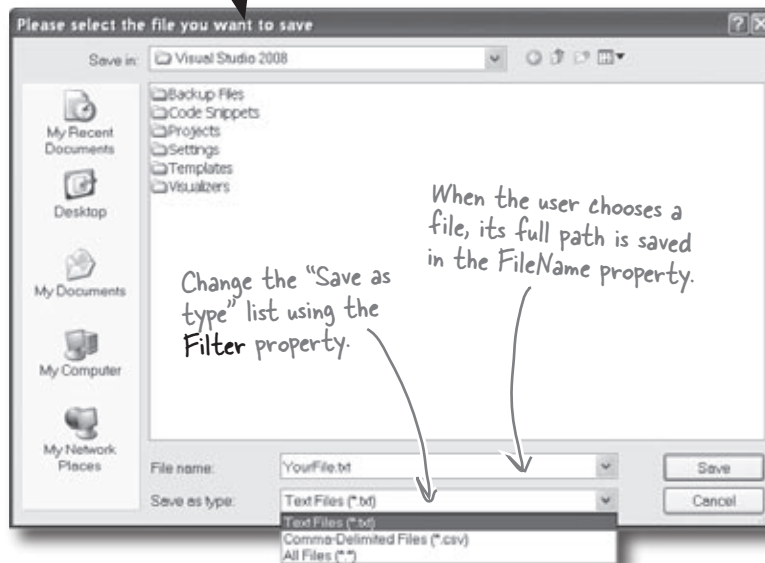

Change the “Save as type” list using the `Filter` property.

When the user chooses a file, its full path is saved in the `FileName` property.

The `DialogResult` returned by the `ShowDialog()` method lets you figure out which button the user clicked.

Use the built-in File and Directory classes to work with files and directories

Like `StreamWriter`, the `File` class creates streams for you to work with files behind the scenes. You can use its methods to do most common actions without having to create the `FileStreams` first. `Directory` objects let you work with whole directories full of files, you can use it to make changes to your file structure easily.

Things you can do with a File:

- 1 **Find out if it exists**
You can check to see if a file exists using the `Exists()` method. It'll return true if it does and false if it doesn't.
- 2 **Read from and write to the file**
You can use the `OpenRead()` method to get data from a file, or the `Create()` or `OpenWrite()` method to write to the file.
- 3 **Append text to the file**
The `AppendAllText()` method lets you append text to an already created file. It even creates the file if it's not there when the method runs.
- 4 **Get information about the file**
The `GetLastAccessTime()` and `GetLastWriteTime()` methods return the date and time when the file was last accessed and modified.

FileInfo works just like File

If you're going to be doing a lot of work with a file, you might want to create an instance of the `FileInfo` class instead of using the `File` class's static methods.

The `FileInfo` class does just about everything the `File` class does except you have to instantiate it to use it. You can create a new instance of `FileInfo` and access its `Exists()` method, or its `OpenRead()` method in just the same way.

The only difference is that the `File` class is faster for a small number of actions and `FileInfo` is better suited for big jobs.

Things you can do with a Directory:

- 1 **Create a new directory**
Create a directory using the `CreateDirectory()` method. All you have to do is supply the path; this method does the rest.
- 2 **Get a list of the files in a directory**
You can create an array of files in a directory using the `GetFiles()` method; just tell the method which directory you want to know about and it will do the rest.
- 3 **Delete a directory**
Deleting a directory is really simple too. Use the `Delete()` method.

there are no Dumb Questions

Q: I still don't get that {0} and {1} thing that was part of the `StreamWriter`.

A: When you're printing strings to a file, you'll often find yourself in the position of having to print the contents of a bunch of variables. For example, you might have to write something like this:

```
writer.WriteLine("My name is " + name +
    "and my age is " + age);
```

It gets really tedious and somewhat error-prone to have to keep using `+` to combine strings. It's easier to take advantage of {0} and {1}:

```
writer.WriteLine(
    "My name is {0} and my age is {1}",
    name, age);
```

It's a lot easier to read that code, especially when many variables are included in the same line.

Q: Why did you put a @ in front of the string that contained the filename?

A: The `Write()` and `WriteLine()` methods support escape sequences like `\n` and `\r`. That makes it difficult to type filenames, which have a lot of backslash characters in them. If you put @ in front of a string, it tells C# not to interpret escape sequences. It also tells C# to include line breaks in your string, so you can hit Enter halfway through the string and it'll include that as a linebreak in the output:

```
string twoLine = @"this is a string
that spans two lines.";
```

Q: And what do `\n` and `\t` mean again?

A: Those are escape sequences. `\n` is a linefeed and `\t` is a tab. `\r` is a return character, or half of a Windows return—in Windows text files, lines have to end with `\r\n`. If you want to use an *actual* backslash in your string, and not have C# interpret it as the beginning of an escape sequence, just do a *double* backslash: `\\`.

Q: What was that in the beginning about converting a string to a byte array? How would that even work?

A: You've probably heard many times that files on a disk are represented as bits and bytes. What that means is that when you write a file to a disk, the operating system treats it as one long sequence of bytes. Remember from Chapter 4 how a `byte` variable can store any number between 0 and 255? Every file on your hard drive is one long sequence of numbers between 0 and 255. It's up to the programs that read and write those files to interpret those bytes as meaningful data. When you open a file in Notepad, it converts each individual byte to a character—for example, `E` is 69 and `a` is 97. And when you type text into Notepad and save it, Notepad converts each of the characters back into a byte and saves it to disk. And if you want to write a `string` to a stream, you'll need to do the same.

Q: If I'm just using a `StreamWriter` to write to a file, why do I really care if it's creating a `FileStream` for me?

A: If you're only reading or writing lines to or from a text file in order, then all you need are `StreamReader` and `StreamWriter`. But as soon as you need to do anything more complex than that, you'll need to start working with other streams. If you ever need to write data like numbers, arrays, collections or objects to a file, a `StreamWriter` just won't do. But don't worry, we'll go into a lot more detail about how that will work in just a minute.

Q: What if I want to create my own dialog boxes? Can I do that?

A: Yes, you definitely can. You can add a new form to your project, design it to look exactly how you want. Then you can create a new instance of it with `new` (just like you created an `OpenFileDialog` object). Then you can call its `ShowDialog()` method, and it'll work just like any other dialog box. We'll talk a lot more about adding other forms to your program in Chapter 13.

Q: Why do I need to worry about closing streams after I'm done with them?

A: Have you ever had a word processor tell you it couldn't open a file because it was "busy"? When one program uses a file, Windows locks it and prevents other programs from using it. And it'll do that for your program when it opens a file. If you don't call the `Close()` method, then it's possible for your program to keep a file locked open until it ends.



.NET has two built-in classes with a bunch of static methods for working with files and folders. The **File** class gives methods to work with files, and the **Directory** class lets you work with directories. Write down what you think each of these lines of code does.

Code	What the code does
<pre>if (!Directory.Exists(@"c:\SYP")) { Directory.CreateDirectory(@"c:\SYP"); }</pre>	
<pre>if (Directory.Exists(@"c:\SYP\Bonk")) { Directory.Delete(@"c:\SYP\Bonk"); }</pre>	
<pre>Directory.CreateDirectory(@"c:\SYP\Bonk");</pre>	
<pre>Directory.SetCreationTime(@"c:\SYP\Bonk", new DateTime(1976, 09, 25));</pre>	
<pre>string[] files = Directory.GetFiles(@"c:\windows\", "*.log", SearchOption.AllDirectories);</pre>	
<pre>File.WriteAllText(@"c:\SYP\Bonk\weirdo.txt", @"This is the first line and this is the second line and this is the last line");</pre>	
<pre>File.Encrypt(@"c:\SYP\Bonk\weirdo.txt");</pre> <p><i>See if you can guess what this one does—you haven't seen it yet.</i></p>	
<pre>File.Copy(@"c:\SYP\Bonk\weirdo.txt", @"c:\SYP\copy.txt");</pre>	
<pre>DateTime myTime = Directory.GetCreationTime(@"c:\SYP\Bonk");</pre>	
<pre>File.SetLastWriteTime(@"c:\SYP\copy.txt", myTime);</pre>	
<pre>File.Delete(@"c:\SYP\Bonk\weirdo.txt");</pre>	

Use File Dialogs to open and save files (all with just a few lines of code)

You can build a program that opens a text file. It'll let you make changes to the file, and saves your changes. with very little code, all using standard .NET controls. Here's how:

1 Build a simple form.

All you need is a textbox and two buttons. Drop the OpenFileDialog and SaveFileDialog controls onto the Form too. Double-click on the buttons to create their event handlers and **add a private string field called name to the form**. Don't forget to put a using statement up top for System.IO.

Do this



2 Hook the Open button up to the openFileDialog.

The Open button shows an OpenFileDialog and then uses File.ReadAllText() to read the file into the text box:

```
private void open_Click(object sender, EventArgs e) {
    if (openFileDialog1.ShowDialog() == DialogResult.OK) {
        name = openFileDialog1.FileName;
        textBox1.Clear();
        textBox1.Text = File.ReadAllText(name);
    }
}
```

Clicking Open shows the OpenFileDialog control.

3 Now, hook up the Save button.

The Save button uses the File.WriteAllText() method to save the file:

```
private void save_Click(object sender, EventArgs e) {
    if (saveFileDialog1.ShowDialog() == DialogResult.OK) {
        name = saveFileDialog1.FileName;
        File.WriteAllText(name, textBox1.Text);
    }
}
```

The ReadAllText() and WriteAllText() methods are part of the File class. That's coming up on the next page. We'll look at them in more detail in just a few pages.

4 Play with the other properties of the dialog boxes.

- ★ Use the Title property of the saveFileDialog to change the text in the title bar.
- ★ Set the initialFolder property to have the dialog OpenFileDialog start in a specified directory.
- ★ Filter the OpenFileDialog so it will only show text files using the Filter property.

If you don't add a filter, then the drop-down lists at the bottom of the open and save dialog boxes will be empty. Try using this filter: "Text Files (.txt)|*.txt"*

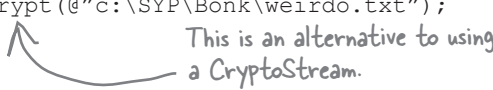

.NET has two built-in classes with a bunch of static methods for working with files and folders. The **File** class gives methods to work with files, and the **Directory** class lets you work with directories. Your job was to write down what each bit of code did.

Code	What the code does
<pre>if (!Directory.Exists(@"c:\SYP")) { Directory.CreateDirectory(@"c:\SYP"); }</pre>	Check if the C:\SYP folder exists. If it doesn't, create it.
<pre>if (Directory.Exists(@"c:\SYP\Bonk")) { Directory.Delete(@"c:\SYP\Bonk"); }</pre>	Check if the C:\SYP\Bonk folder exists. If it does, delete it.
<pre>Directory.CreateDirectory(@"c:\SYP\Bonk");</pre>	Create the directory C:\SYP\Bonk.
<pre>Directory.SetCreationTime(@"c:\SYP\Bonk", new DateTime(1976, 09, 25));</pre>	Set the creation time for the C:\SYP\Bonk folder to September 25, 1976.
<pre>string[] files = Directory.GetFiles(@"c:\windows\", "*.log", SearchOption.AllDirectories);</pre>	Get a list of all files in C:\Windows that match the *.log pattern, including all matching files in any subdirectory.
<pre>File.WriteAllText(@"c:\SYP\Bonk\weirdo.txt", @"This is the first line and this is the second line and this is the last line");</pre>	Create a file called "weirdo.txt" (if it doesn't already exist) in the C:\SYP\Bonk folder and write three lines of text to it.
<pre>File.Encrypt(@"c:\SYP\Bonk\weirdo.txt");</pre> <p> This is an alternative to using a CryptoStream.</p>	Take advantage of built-in Windows encryption to encrypt the file "weirdo.txt" using the logged in account's credentials..
<pre>File.Copy(@"c:\SYP\Bonk\weirdo.txt", @"c:\SYP\copy.txt");</pre>	Copy the C:\SYP\Bonk\weirdo.txt file to C:\SYP\Copy.txt.
<pre>DateTime myTime = Directory.GetCreationTime(@"c:\SYP\Bonk");</pre>	Declare the myTime variable and set it equal to the creation time of the C:\SYP\Bonk folder.
<pre>File.SetLastWriteTime(@"c:\SYP\copy.txt", myTime);</pre>	Alter the last write time of the copy.txt file in C:\SYP\ so it's equal to whatever time is stored in the myTime variable.
<pre>File.Delete(@"c:\SYP\Bonk\weirdo.txt");</pre>	Delete the C:\SYP\Bonk\weirdo.txt file.

IDisposable makes sure your objects are disposed properly

A lot of .NET classes implement a particularly useful interface called `IDisposable`. It **only has one member**: a method called `Dispose()`. Whenever a class implements `IDisposable`, it's telling you that there are important things that it needs to do in order to shut itself down, usually because it's **allocated resources** that it won't give back until you tell it to. The `Dispose()` method is how you tell the object to release those resources.

You can use the "Go To Definition" feature in the IDE to show you the official C# definition of `IDisposable`. Go to your project and type `IDisposable` anywhere inside the code. Then right-click on it and select "Go To Definition" from the menu. It'll open a new tab with code in it. Expand all of the code and this is what you'll see:

You'll learn more about "Go To Definition" later on.

Declare an object in a using block and that object's `Dispose()` method is called automatically.

```
namespace System
```

```
{
```

```
    // Summary:
```

```
    //     Defines a method to release allocated resources.
```

```
public interface IDisposable
```

```
{
```

```
    // Summary:
```

```
    //     Performs application-defined tasks
```

```
    //     associated with freeing, releasing, or
```

```
    //     resetting unmanaged resources.
```

```
void Dispose();
```

```
}
```

```
}
```

A lot of classes allocate important resources, like memory, files, and other objects. That means they take them over, and don't give them back until you tell them you're done with those resources.

Any class that implements `IDisposable` will immediately release any resources that it took over as soon as you call its `Dispose()` method. It's almost always the last thing you do before you're done with the object.

Go To Definition

There's a handy feature in the IDE that lets you automatically jump to the definition for any variable, object or method. Just right-click on it and select "Go To Definition", and the IDE will automatically jump right to the code that defines it.

al-lo-cate, verb.
to distribute resources or duties for a particular purpose. *The programming team was irritated at their project manager because he **allocated** all of the conference rooms for a useless management seminar.*

Avoid file system errors with using statements

We've been telling you all chapter that you need to **close your streams**. That's because some of the most common bugs that programmers run across when they deal with files are caused when streams aren't closed properly. Luckily, C# gives you a great tool to make sure that never happens to you: `IDisposable` and the `Dispose()` method. When you **wrap your stream code in a using statement**, it automatically closes your streams for you. All you need to do is **declare your stream reference** with a using statement, followed by a block of code (inside curly brackets) that uses that reference. When you do that, the using statement **automatically calls the stream's `Dispose()` method** as soon as it finishes running the block of code. Here's how it works:

These "using" statements are different from the ones at the top of your code.

...and then a block of code within curly braces.

A using statement is always followed by an object declaration...

```
using (StreamWriter sw = new StreamWriter("secret_plan.txt")) {  
    sw.WriteLine("How I'll defeat Captain Amazing");  
    sw.WriteLine("Another genius secret plan");  
    sw.WriteLine("by The Swindler");  
}
```

These statements can use the object created in the using statement above like any normal object.

When the using statement ends, the `Dispose()` method of the object being used is run.

In this case, the object being used is pointed to by `sw`—which was declared in the using statement—so the `Dispose()` method of the `Stream` class is run...which closes the stream.

Every stream has a `Dispose()` method that closes the stream. So if you declare your stream in a using statement, it will always close itself!

Use multiple using statements for multiple objects

You can pile using statements on top of each other—you don't need extra sets of curly brackets or indents.

```
using (StreamReader reader = new StreamReader("secret_plan.txt"))  
using (StreamWriter writer = new StreamWriter("email.txt"))  
{  
    // statements that use reader and writer  
}
```

You don't need to call `Close()` on the streams now, because the using statement will close them automatically.

Any time you use a stream, you should **ALWAYS** declare it inside a using statement. That makes sure it's always closed!

Trouble at work

Meet Brian. He likes his job as a C# developer, but he *loves* taking the occasional day off. But his boss **hates** when people take vacation days, so Brian's got to come up with a good excuse.



You can help Brian out by building a program to manage his excuses

Use what you know about reading and writing files to build an excuse manager that Brian can use to keep track of which excuses he's used recently and how well they went over with the boss.

This asterisk appears when a form has unsaved data.

Brian wants to keep all of his excuses in one place, so let's let him select a folder to store all of them.

Sometimes Brian's too lazy to think up an excuse. Let's add a button to load up a random excuse from his excuse folder.

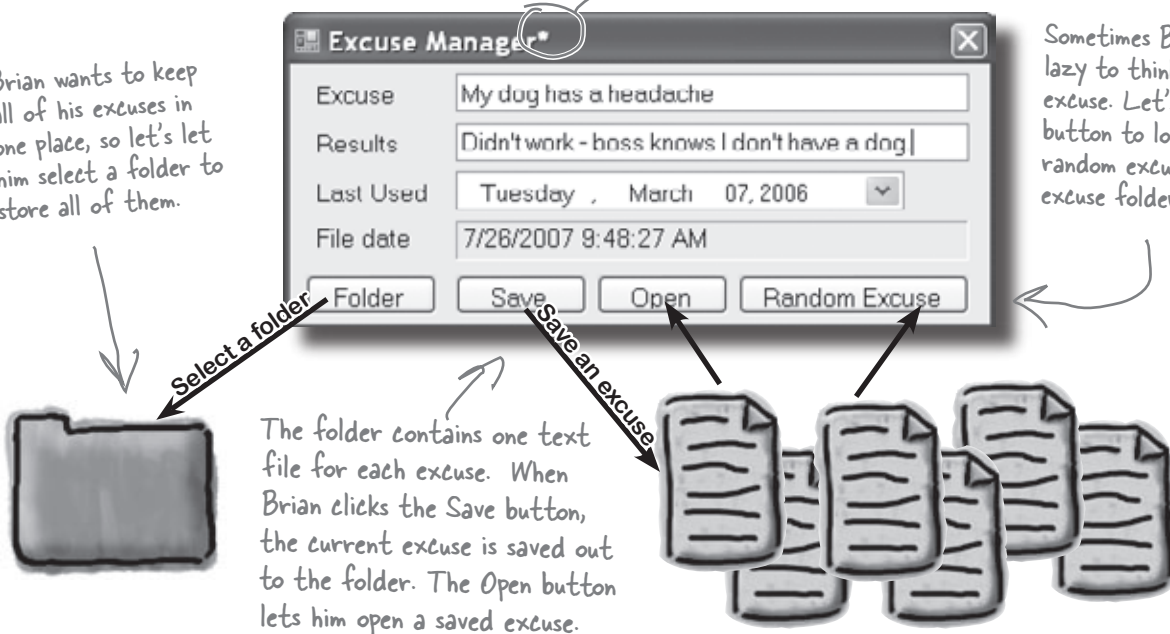

The folder contains one text file for each excuse. When Brian clicks the Save button, the current excuse is saved out to the folder. The Open button lets him open a saved excuse.



Exercise

Build the excuse manager so Brian can manage his excuses at work.

Excuse
Description: string
Results: string
LastUsed: DateTime
ExcusePath: string
OpenFile(string)
Save(string)

1 Build the form

This form has a few special features:

- ★ When the form's first loaded, **only the Folder button should be enabled**—disable the other three buttons until the user selects a folder.
- ★ When the form opens or saves an excuse, it displays the file date for the excuse file using a Label control with AutoSize set to False and BorderStyle set to Fixed3D.
- ★ After an excuse is saved, the form pops up an “Excuse Written” message box.
- ★ The Folder button brings up a folder browser dialog box. If the user selects a folder, it enables the Save, Open, and Random Excuse buttons.
- ★ The form knows when there are unsaved changes. When there are no unsaved changes, the text on the form's title bar is “Excuse Manager”. But when the user has changed any of the three fields, the form adds an asterisk (*) to the title bar. The asterisk goes away when the data is saved or a new excuse is opened.
- ★ The form will need to keep track of the current folder and whether or not the current excuse has been saved. You can figure out when the excuse hasn't been saved by **using the Changed event handlers** for the three input controls. ←

When you drag a textbox to a form and double-click on it, you create a Changed event handler for that field.

2 Create an Excuse class and store an instance of it in the form

Now add a CurrentExcuse field to the form to hold the current excuse. You'll need **three overloaded constructors**: one for when the form's first loaded, one for opening up a file, and one for a random excuse. Add methods OpenFile () to open an excuse (for the constructors to use), and Save () to save the excuse. Then add this UpdateForm () method to update the controls (it'll give you some **hints** about the class):

```
private void UpdateForm(bool Changed) {
    if (!Changed) {
        this.description.Text = currentExcuse.Description;
        this.results.Text = currentExcuse.Results;
        this.lastUsed.Value = currentExcuse.LastUsed;
        if (!string.IsNullOrEmpty(currentExcuse.ExcusePath))
            FileDate.Text = File.GetLastWriteTime(currentExcuse.ExcusePath).ToString();
        this.Text = "Excuse Manager";
    }
    else
        this.Text = "Excuse Manager*";
    this.formChanged = Changed;
}
```

Remember, the ! means NOT—so this checks if the excuse path is NOT null or empty.

This parameter indicates whether or not the form has changed. You'll need a field in your form to keep track of this status.

Double-click on the input controls so the IDE builds Changed event handlers for you. The event handlers for the three input controls will first change the Excuse instance and then call UpdateForm(true)—then it's up to you to change the fields on your form.

3 Make the Folder button open a folder browser

When the user clicks on the Folder button, the form should pop up a “Browse for Folder” dialog box. The form will need to store the folder in a field so that the other dialog boxes can use it. When the form **first loads**, the Save, Open, and Random Excuse buttons are **disabled**, but if the user selects a folder then the Folder button enables them.

3 Make Save button save the current excuse to a file

Clicking the Save button should bring up the Save As dialog box.

- ★ Each excuse is saved to a separate text file. The first line of the file is the excuse, the second is the result, and the third is the date last used (use the `DateTimePicker`'s `ToString()` method). The `Excuse` class should have a `Save()` method to save an excuse out to a specified file.
- ★ When the Save As dialog box is opened, its folder should be set to the folder that the user selected using the Folder button, and the filename should be set to the excuse plus a ".txt" extension.
- ★ The dialog box should have two filters: Text Files (*.txt) and All Files (*.*)
- ★ If the user tries to save the current excuse but has left either the excuse or the result blank, the form should pop up a warning dialog box:

You can display this Exclamation icon by using the overloaded `MessageBox.Show()` method that allows you to specify a `MessageBoxIcon` parameter.

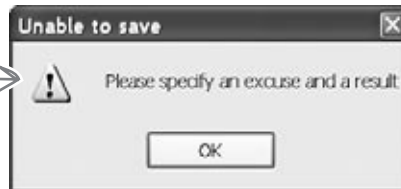

4 Make the Open button open a saved excuse

Clicking the Open button should bring up the Open dialog box.

- ★ When the Open dialog box is opened, its folder should be set to the folder that the user selected using the Folder button.
- ★ Add an `Open()` method to the `Excuse` class to open an excuse from a given file.
- ★ Use `Convert.ToDateTime()` to load the saved date into the `DateTimePicker` control.
- ★ If the user tries to open a saved excuse but the current excuse hasn't been saved, it pops up this dialog box:

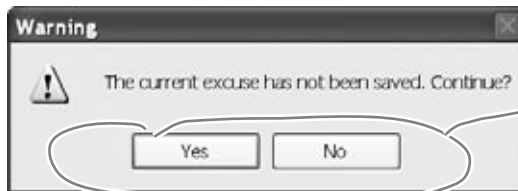

Show a Yes/No dialog box by using the overloaded `MessageBox.Show()` method that lets you specify the `MessageBoxButtons.YesNo` parameter. If the user clicks "No", then `Show()` returns `DialogResult.No`.

5 Finally, make the Random Excuse button load a random excuse

When the user clicks the Random Excuse button, it looks in the excuse folder, chooses one of the excuses at random, and opens it.

- ★ The form will need to save a `Random` object in a field and pass it to one of the overloaded constructors of the `Excuse` object.
- ★ If the current excuse hasn't been saved, the button should pop up the same warning dialog box as the Open button.



Exercise Solution

Build the excuse manager so Brian can manage his excuses at work.

```
private Excuse currentExcuse = new Excuse();
private string selectedFolder = "";
private bool formChanged = false;
Random random = new Random();
```

The form uses fields to store the current Excuse object, the selected folder, remember whether or not the current excuse has changed, and keep a Random object for the Random Excuse button.

```
private void folder_Click(object sender, EventArgs e) {
    folderBrowserDialog1.SelectedPath = selectedFolder;
    DialogResult result = folderBrowserDialog1.ShowDialog();
    if (result == DialogResult.OK) {
        selectedFolder = folderBrowserDialog1.SelectedPath;
        save.Enabled = true;
        open.Enabled = true;
        randomExcuse.Enabled = true;
    }
}
```

If the user selected a folder, the form saves the folder name and then enables the other three buttons.

The two vertical bars mean OR—this is true if description is empty OR results is empty.

```
private void save_Click(object sender, EventArgs e) {
    if (String.IsNullOrEmpty(description.Text) || String.IsNullOrEmpty(results.Text)) {
        MessageBox.Show("Please specify an excuse and a result",
            "Unable to save", MessageBoxButtons.OK, MessageBoxIcon.Exclamation);
        return;
    }
    saveFileDialog1.InitialDirectory = selectedFolder;
    saveFileDialog1.Filter = "Text files (*.txt)|*.txt|All files (*.*)|*.*";
    saveFileDialog1.FileName = description.Text + ".txt";
    DialogResult result = saveFileDialog1.ShowDialog();
    if (result == DialogResult.OK) {
        currentExcuse.Save(saveFileDialog1.FileName);
        UpdateForm(false);
        MessageBox.Show("Excuse written");
    }
}
```

Here's where the filters are set for the Save As dialog.

This will cause two rows to show up in the "Files of Type" dropdown at the bottom of the Save dialog box: one for Text Files (*.txt), and one for All Files (*.*)

```
private void open_Click(object sender, EventArgs e) {
    if (CheckChanged()) {
        openFileDialog1.InitialDirectory = selectedFolder;
        openFileDialog1.Filter = "Text files (*.txt)|*.txt|All files (*.*)|*.*";
        openFileDialog1.FileName = description.Text + ".txt";
        DialogResult result = openFileDialog1.ShowDialog();
        if (result == DialogResult.OK) {
            currentExcuse = new Excuse(openFileDialog1.FileName);
            UpdateForm(false);
        }
    }
}
```

Use the DialogResult enum returned by the Open and Save dialog boxes to make sure you only open or save if the user clicked "OK", and not "Cancel".

```
private void randomExcuse_Click(object sender, EventArgs e) {
    if (CheckChanged()) {
        currentExcuse = new Excuse(random, selectedFolder);
        UpdateForm(false);
    }
}
```

```
private bool CheckChanged() {
    if (formChanged) {
        DialogResult result = MessageBox.Show(
            "The current excuse has not been saved. Continue?",
            "Warning", MessageBoxButtons.YesNo, MessageBoxIcon.Warning);
        if (result == DialogResult.No)
            return false;
    }
    return true;
}
```

MessageBox.Show() also returns a DialogResult enum that we can check.

Here are the three Changed event handlers for the three input fields on the form. If any of them are triggered, that means the excuse has changed, so first we update the Excuse instance and then we call UpdateForm(), add the asterisk to the form's title bar, and set Changed to true.

```
private void description_TextChanged(object sender, EventArgs e) {
    currentExcuse.Description = description.Text;
    UpdateForm(true);
}
```

```
private void results_TextChanged(object sender, EventArgs e) {
    currentExcuse.Results = results.Text;
    UpdateForm(true);
}
```

```
private void lastUsed_ValueChanged(object sender, EventArgs e) {
    currentExcuse.LastUsed = lastUsed.Value;
    UpdateForm(true);
}
```

Passing true to UpdateForm() tells it to just mark the form as changed, but not update the input controls.

```
public class Excuse {
    public string Description;
    public string Results;
    public DateTime LastUsed;
    public string ExcusePath;
    public Excuse() {
        ExcusePath = "";
    }
    public Excuse(string excusePath) {
        OpenFile(excusePath);
    }
    public Excuse(Random random, string folder) {
        string[] fileNames = Directory.GetFiles(folder, "*.txt");
        OpenFile(fileNames[random.Next(fileNames.Length)]);
    }
    private void OpenFile(string excusePath) {
        this.ExcusePath = excusePath;
        using (StreamReader reader = new StreamReader(excusePath)) {
            Description = reader.ReadLine();
            Results = reader.ReadLine();
            LastUsed = Convert.ToDateTime(reader.ReadLine());
        }
    }
    public void Save(string fileName) {
        using (StreamWriter writer = new StreamWriter(fileName)) {
            {
                writer.WriteLine(Description);
                writer.WriteLine(Results);
                writer.WriteLine>LastUsed.ToString());
            }
        }
    }
}
```

The Random Excuse button uses Directory.GetFiles() to read all of the text files in the selected folder into an array, and then chooses a random array index to open.

We made sure to use a using statement every time we opened a stream. That way our files will always be closed.

Here's where the using statement comes in. We declared the StreamWriter inside of a using statement, so its Close() method is called for us automatically!

Writing files usually involves making a lot of decisions

You'll write lots of programs that take a single input, maybe from a file, and have to decide what to do based on that input. Here's code that uses one long `if` statement—it's pretty typical. It checks the `part` variable and prints different lines to the file based on which enum it uses. There are lots of choices, so lots of `else ifs`:

```
enum BodyPart {  
    Head,  
    Shoulders,  
    Knees,  
    Toes  
}
```

Here's an enum—we'll want to compare a variable against each of the four members and write a different line to the `StreamWriter` depending on which one it matches. We'll also write something different if none of them match.

```
private void WritePartInfo(BodyPart part, StreamWriter writer) {  
    if (part == BodyPart.Head)  
        writer.WriteLine("the head is hairy");  
    else if (part == BodyPart.Shoulders)  
        writer.WriteLine("the shoulders are broad");  
    else if (part == BodyPart.Knees)  
        writer.WriteLine("the knees are knobby");  
    else if (part == BodyPart.Toes)  
        writer.WriteLine("the toes are teeny");  
    else  
        writer.WriteLine("some unknown part is unknown");  
}
```

If we use a series of `if/else` statements, then we end up writing this "`if (part == [option])`" over and over.

We've got a final `else` in case we didn't find a match.



What sort of things can go wrong when you write code that has this many `if/else` statements? Think about typos and bugs caused by brackets, a single equals sign, etc.

Use a switch statement to choose the right option

Comparing one variable against a bunch of different values is a really common pattern that you'll see over and over again. It's especially common when you're reading and writing files. It's so common, in fact, that C# has a special kind of statement designed specifically for this situation.

A **switch statement** lets you compare one variable against many values in a way that's easy to read and is compact. Here's a switch statement that does exactly the same thing as the series of `if/else` statements on the opposite page:

There's nothing about a switch statement that's specifically related to files. It's just a useful C# tool that we can use here.

A switch statement compares ONE variable against MULTIPLE possible values.

```
enum BodyPart
{
    Head,
    Shoulders,
    Knees,
    Toes,
}

private void WritePartInfo(BodyPart part, StreamWriter writer)
{
    switch (part) {
        case BodyPart.Head:
            writer.WriteLine("the head is hairy");
            break;
        case BodyPart.Shoulders:
            writer.WriteLine("the shoulders are broad");
            break;
        case BodyPart.Knees:
            writer.WriteLine("the knees are knobby");
            break;
        case BodyPart.Toes:
            writer.WriteLine("the toes are teeny");
            break;
        default:
            writer.WriteLine("some unknown part is unknown");
            break;
    }
}
```

You'll start with the `switch` keyword followed by the variable that's going to be compared against a bunch of different possible values.

Every case ends with "`break;`" so C# knows where one case ends and the next begins.

You can also end a case with "`return`" - the program will compile as long as there's no way for one case to "fall through" to the next one.

Switch statements can end with a `default:` block that gets executed if none of the other cases are matched.

The body of the switch statement is a series of cases that compare whatever follows the `switch` keyword against a particular value.

Each of these cases consists of the `case` keyword followed by the value to compare and a colon. After that is a series of statements followed by "`break;`". Those statements will be executed if the case matches the comparison value.

Use a switch statement to let your deck of cards read from a file or write itself out to one

Writing a card out to a file is straightforward—just make a loop that writes the name of each card out to a file. Here’s a method you can add to the Deck object that does exactly that:

```
public void WriteCards(string Filename) {
    using (StreamWriter writer = new StreamWriter(Filename)) {
        for (int i = 0; i < Cards.Count; i++) {
            writer.WriteLine(Cards[i].Name);
        }
    }
}
```

But what about reading the file in? It’s not quite so simple. That’s where the switch statement can come in handy.

```
Card.Suits suit;
switch (suitString) (
    case "Spades":
        suit = Card.Suits.Spades;
        break;
    case "Clubs":
        suit = Card.Suits.Clubs;
        break;
    case "Hearts":
        suit = Card.Suits.Hearts;
        break;
    case "Diamonds":
        suit = Card.Suits.Diamonds;
        break;
    default:
        MessageBox.Show(suitString + " isn't a valid suit!");
}
```

The switch statement starts with a value to compare against. This switch statement is called from a method that has a suit stored in a string.

Each of these case lines compares some value against the value in the switch line. If they match, it executes all of the following statements until it hits a break.

The default line comes at the end. If none of the cases match, the statements after the default get executed instead.

The switch statement lets you test one value against a bunch of cases and execute different statements depending on which one it matches.

Add an overloaded Deck() constructor that reads a deck of cards in from a file

You can use a switch statement to build a new constructor for the Deck class that you wrote in the last chapter. This constructor reads in a file and checks each line for a card. Any valid card gets added to the deck.

There's a method that you can find on every string that'll come in handy: `Split()`. It lets you split the string into an array of substrings by passing it a `char[]` array of separator characters that it'll use to split the string up.

```
public Deck(string Filename) {
    cards = new List<Card>();
    StreamReader reader = new StreamReader(Filename);
    while (!reader.EndOfStream) {
        bool invalidCard = false;
        string nextCard = reader.ReadLine();
        string[] cardParts = nextCard.Split(new char[] { ' ' });
        Card.Values value = Card.Values.Ace;
        switch (cardParts[0]) {
            case "Ace": value = Card.Values.Ace; break;
            case "Two": value = Card.Values.Two; break;
            case "Three": value = Card.Values.Three; break;
            case "Four": value = Card.Values.Four; break;
            case "Five": value = Card.Values.Five; break;
            case "Six": value = Card.Values.Six; break;
            case "Seven": value = Card.Values.Seven; break;
            case "Eight": value = Card.Values.Eight; break;
            case "Nine": value = Card.Values.Nine; break;
            case "Ten": value = Card.Values.Ten; break;
            case "Jack": value = Card.Values.Jack; break;
            case "Queen": value = Card.Values.Queen; break;
            case "King": value = Card.Values.King; break;
            default: invalidCard = true; break;
        }
        Card.Suits suit = Card.Suits.Clubs;
        switch (cardParts[2]) {
            case "Spades": suit = Card.Suits.Spades; break;
            case "Clubs": suit = Card.Suits.Clubs; break;
            case "Hearts": suit = Card.Suits.Hearts; break;
            case "Diamonds": suit = Card.Suits.Diamonds; break;
            default: invalidCard = true; break;
        }
        if (!invalidCard) {
            cards.Add(new Card(suit, value));
        }
    }
}
```

This line tells C# to split the `nextCard` string using a space as a separator character. That splits the string "Six of Diamonds" into the array {"Six", "of", "Diamonds"}.

This switch statement checks the first word in the line to see if it matches a value. If it does, the right value is assigned to the value variable.

We do the same thing for the third word in the line, except we convert this one to a suit.



All that code just to read in one simple card?
That's way too much work! What if my object has a
whole bunch of fields and values? Are you telling me I
need to write a switch statement for each of them?

There's an easier way to store your objects in files. It's called *serialization*.

Instead of painstakingly writing out each field and value to a file line by line, you can save your object the easy way by serializing it out to a stream. **Serializing** an object is like **flattening it out** so you can slip it into a file. And on the other end, you can **deserialize** it, which is like taking it out of the file and **inflating** it again.

What happens to an object when it's serialized?

It seems like something mysterious has to happen to an object in order to copy it off of the heap and put it into a file, but it's actually pretty straightforward.

1 Object on the heap



When you create an instance of an object, it has a **state**. Everything that an object “knows” is what makes one instance of a class different from another instance of the same class.

2 Object serialized



When C# serializes an object, it **saves the complete state of the object**, so that an identical instance (object) can be brought back to life on the heap later.

This object has two byte fields, width and height.

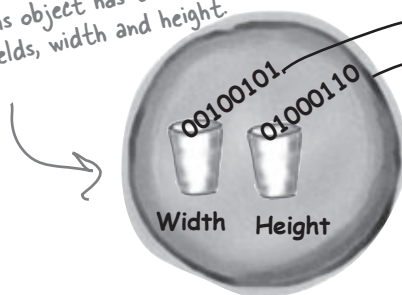

The values are sucked out and pumped into the stream.

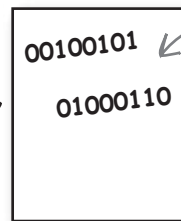

file.dat

The instance variable values for width and height are saved to the file “file.dat”, along with a little more info that the CLR needs to restore the object later (like the type of the object and each of its fields.)

Object on the heap again



3 And later on...

Later—maybe days later, and in a different program—you can go back to the file and **deserialize** it. That pulls the original class back out of the file and restores it **exactly as it was**, with all of its fields and values intact.

But what exactly IS an object's state? What needs to be saved?

We already know that **an object stores its state in its fields**. So when an object is serialized, every one of those those fields needs to be saved to the file.

Serialization starts to get interesting when you have more complicated objects. 37 and 70 are bytes—those are value types, so they can just be written out to a file as-is. But what if an object has an instance variable that's an object *reference*? What about an object that has five instance variables that are object references? What if those object instance variables themselves have instance variables?

Think about it for a minute. What part of an object is potentially unique? Imagine what needs to be restored in order to get an object that's identical to the one that was saved. Somehow everything on the heap has to be written to the file.



BRAIN BARBELL

What has to happen for this Car object to be saved so that it gets restored back to its original state? Let's say the car has three passengers and a 3-liter engine and all-weather radial tires... aren't those things all part of the Car object's state? What should happen to them?

The Car object has references to an Engine object, an array of Tire objects, and a List<> of Passenger objects. Those are part of its state, too—what happens to them?

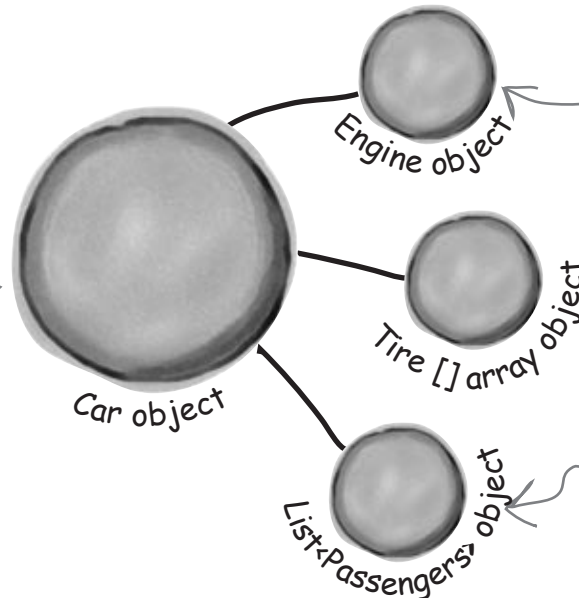

The Engine object is private. Should it be saved, too?

Each of the passenger objects has its own references to other objects. Do those need to be saved, too?

When an object is serialized, all of the objects it refers to get serialized too...

...and all of the objects *they* refer to, and all of the objects *those other objects* refer to, and so on and so on. But don't worry—it may sound complicated, but it all happens automatically. C# starts with the object you want to serialize and looks through its fields for other objects. Then it does the same for each of them. Every single object gets written out to the file, along with all the information C# needs to reconstitute it all when the object gets deserialized.

Some people call this whole group of connected objects a "graph."

When you ask C# to serialize the Kennel object, it looks for any field that has a reference to another object.

One of the fields of the Kennel object is this List<Dog> that contains two Dog objects, so C# will need to serialize them, too.

Each of the two Dog objects has references to a DoggyID object and a Collar object. They'll need to get serialized along with each Dog.

DoggyID and Collar are the end of the line—they don't have references to any other objects.

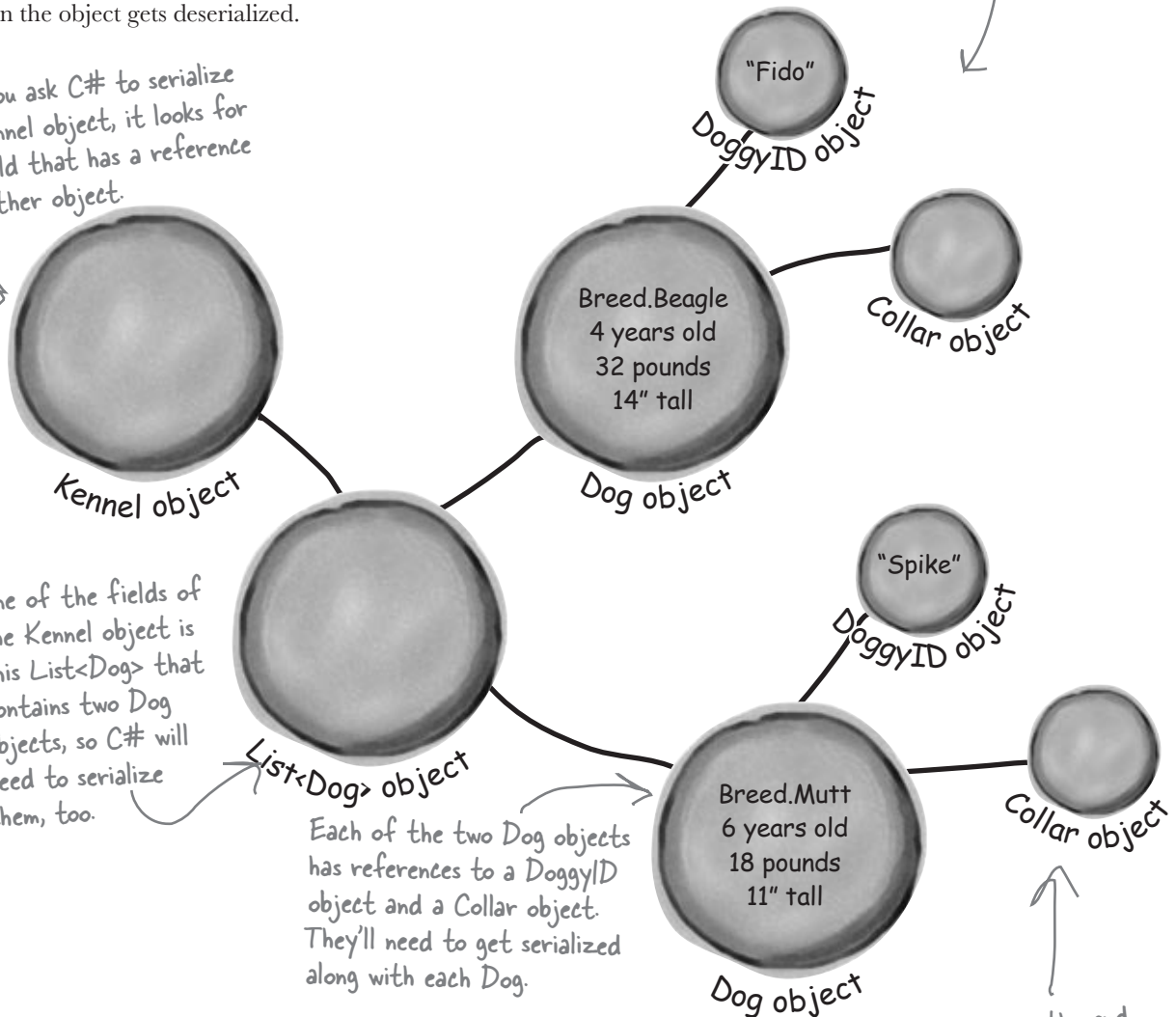

Serialization lets you read or write a whole object all at once

You're not just limited to reading and writing lines of text to your files. You can use **serialization** to let your programs copy entire objects to files and read them back in... all in just a few lines of code! There's a tiny amount of prep work you need to do—add one `[Serializable]` line to the top of the class to serialize—but once you do that, everything's ready to write.

You'll need a `BinaryFormatter` object

If you want to serialize an object—*any* object—the first thing you do is create an instance of `BinaryFormatter`. It's really straightforward to do—and all it takes is one line of code (and an extra `using` line at the top of the class file).

```
using System.Runtime.Serialization.Formatters.Binary;
...
BinaryFormatter formatter = new BinaryFormatter();
```

Now just create a stream and read or write your objects

Use the `Serialize()` method from the `BinaryFormatter` object to write any object out to a stream.

```
Stream output = File.Create(filenameString);
formatter.Serialize(output, objectToSerialize);
output.Close();
```

↑ If you use a `using` statement, `Close()` will be called automatically.

The `File.Create()` method creates a new file. You can open an existing one using `File.OpenWrite()`.

↑ The `Serialize()` method takes an object and writes it out to a stream. That's a whole lot easier than building a method to write it out yourself!

And once you've got an object serialized out to a file, use the `BinaryFormatter` object's `Deserialize()` method to read it back in. The method returns a reference, so you need to cast the output so that it matches the type of the reference variable you're copying it to.

```
Stream input = File.OpenRead(filenameString);
SomeObj obj = (SomeObj)formatter.Deserialize(input);
input.Close();
```

↑ When you use `Deserialize()` to read an object back from a stream, don't forget to cast the return value to match the type of object you're reading.

It's quick to copy an object out to a file or read it in from one. You can serialize or deserialize it.

If you want your class to be serializable, mark it with the [Serializable] attribute

An **attribute** is a special tag that you can add to the top of any C# class. It's how C# stores **metadata** about your code, or information about how the code should be used or treated. When you **add [Serializable] to the top of a class just above the class declaration**, you're telling C# that your class is safe for serialization. And you only use it with classes that include fields that are either value types (like an `int`, `string`, or `enum`) or other serializable classes. If you don't add the attribute to the class you want to serialize, or if you include a field with a type that isn't serializable, then your program will have an error when you try to run it. *See for yourself...*

1 Create a class and serialize it

Remember the Guy Class from Chapter 3? Let's serialize Joe so we can keep a file that knows how much money he's got in his pockets even after you close your program.

```
[Serializable]
public class Guy
```

You need to add this attribute to the top of any class in order to serialize it.

Here's code to serialize it to a file called "Guy_file.dat"—add a "Save Joe" button and a "Load Joe" button to the Form

```
using System.IO;
using System.Runtime.Serialization.Formatters.Binary;
...

private void saveJoe_Click(object sender, EventArgs e)
{
    using (Stream output = File.Create("Guy_File.dat")) {
        BinaryFormatter formatter = new BinaryFormatter();
        formatter.Serialize(output, joe);
    }
}

private void loadJoe_Click(object sender, EventArgs e)
{
    using (Stream input = File.OpenRead("Guy_File.dat")) {
        BinaryFormatter formatter = new BinaryFormatter();
        joe = (Guy) formatter.Deserialize(input);
    }
    UpdateForm();
}
```

You'll need these two using lines. The first one is for the file and stream methods, and the second is for serialization.



2 Run the program and play around with it.

If Joe had two hundred dollars saved up from his transactions with Bob during your time running the program, it would be a pain to lose all that money just because you needed to exit. Now your program can save Joe out to a file and restore him whenever you want.

Let's serialize and deserialize a deck of cards

Take a deck of cards and write it out to a file. C# makes serializing objects really easy. All you need to do is create a stream and write out your objects.



1 Create a new project and add the Deck and Card classes

Right-click on the project in the Solution Explorer and choose “Add/Existing Item”, and add the Card and Deck classes you created in Chapter 7. You’ll also need to add the two card comparer classes, since Deck uses them. The IDE will copy the files into the new project—make sure you change the namespace line at the top of each class file to match your new project’s namespace.

2 Mark all of the classes serializable

Add the [Serializable] attribute to all of the classes you added to the project.

If you don't do this, C# won't let you serialize the classes to a file.

3 Add a couple of useful methods to the form

The RandomDeck method creates a random deck of cards, and the DealCards method deals all of the cards and prints them to the console.

```
Random random = new Random();
private Deck RandomDeck(int Number) {
    Deck myDeck = new Deck(new Card[] { });
    for (int i = 0; i < Number; i++)
    {
        myDeck.Add(new Card(
            (Card.Suits)random.Next(4),
            (Card.Values)random.Next(1, 14)));
    }
    return myDeck;
}
```

This creates an empty deck and then adds some random cards to it using the Card class from the last chapter.

```
private void DealCards(Deck DeckToDeal, string Title) {
    Console.WriteLine(Title);
    while (DeckToDeal.Count > 0)
    {
        Card nextCard = DeckToDeal.Deal(0);
        Console.WriteLine(nextCard.Name);
    }
    Console.WriteLine("-----");
}
```

The DealCards() method deals each of the cards off of the deck and prints it to the console.

4 Okay, prep work's done.. now serialize that deck

Start by adding buttons to serialize a random deck to a file and read it back. Check the console output to make sure the deck you wrote out is the same as the deck you read.

```
private void button1_Click(object sender, EventArgs e) {
    Deck deckToWrite = RandomDeck(5);
    using (Stream output = File.Create("Deck1.dat")) {
        BinaryFormatter bf = new BinaryFormatter();
        bf.Serialize(output, deckToWrite);
    }
    DealCards(deckToWrite, "What I just wrote to the file");
}

private void button2_Click(object sender, EventArgs e) {
    using (Stream input = File.OpenRead("Deck1.dat")) {
        BinaryFormatter bf = new BinaryFormatter();
        Deck deckFromFile = (Deck)bf.Deserialize(input);
    }
    DealCards(deckFromFile, "What I read from the file");
}
```

The BinaryFormatter object takes any object marked with the Serializable attribute—in this case a Deck object—and writes it out to a stream using its Serialize() method.

The BinaryFormatter's Deserialize() method returns an Object, which is just the general type that every C# object inherits from—which is why we need to cast it to a Deck object.

5 Now serialize a bunch of decks to the same file

Once you open a stream, you can write as much as you want to it. You can serialize as many objects as you need into the same file. So now add two more buttons to write out a random number of decks to the file. Check the output to make sure everything looks good.

```
private void button3_Click(object sender, EventArgs e) {
    using (Stream output = File.Create("Deck1.dat")) {
        BinaryFormatter bf = new BinaryFormatter();
        for (int i = 1; i <= 5; i++) {
            Deck deckToWrite = RandomDeck(random.Next(1,10));
            bf.Serialize(output, deckToWrite);
            DealCards(deckToWrite, "Deck #" + i + " written");
        }
    }

    private void button4_Click(object sender, EventArgs e) {
        using (Stream input = File.OpenRead("Deck1.dat")) {
            BinaryFormatter bf = new BinaryFormatter();
            for (int i = 1; i <= 5; i++) {
                Deck deckToRead = (Deck)bf.Deserialize(input);
                DealCards(deckToRead, "Deck #" + i + " read");
            }
        }
    }
}
```

You can serialize one object after another to the same stream.

Notice how the line that reads a single deck from the file uses (Deck) to cast the output of Deserialize() to a Deck. That's because Deserialize() returns an object, but doesn't necessarily know what type of object.

As long as you cast the objects you read off the stream to the right type, there's no limit to the number of objects you can serialize.

6 Take a look at the file you wrote

Open up Deck1.dat in Notepad. It may not be quite something you'd read on the beach, but it's got all the information to restore your whole deck of cards.



Wait a minute. I'm not sure I like all this writing objects out to some weird file that looks like garbage when I open it up. When I wrote the deck of cards as strings, I could open up the output in Notepad and see everything in it. Isn't C# supposed to make it easy for me to understand everything I'm doing?

When you serialize objects out to a file, they're written in a binary format.

But that doesn't mean it's indecipherable—just compact. That's why you can recognize the strings when you open up a file with serialized objects in it: that's the most compact way C# can write strings to a file—as strings. But writing out a number as a string would be really wasteful. Any `int` can be stored in four bytes. So it would be odd if C# stored, say, the number 49,369,144 as an 8-character string that you could read—10 characters if you include commas. That would be a waste of space!

Behind the Scenes



.NET uses **Unicode** to encode a char or string into bytes. Luckily, Windows has a useful little tool to help us figure out how Unicode works. Open up the Character Map (it's in the Start menu under Accessories, or do Start / Run and type "charmap.exe").

When you look at all the letters and symbols that are used in languages all around the world, you realize just how many different *things* need to be written to a file just to store text. That's why .NET **encodes** all of its strings and characters in a format called Unicode. Encoding just means taking the logical data (like the letter H) and turning it into bytes (the number 72). It needs to do that because letters, numbers, enums and other data all end up in bytes on disk or in memory. And that's why Character Map's useful—it shows you how letters are encoded into numbers.

Select the Arial font and scroll down until you reach the Hebrew letters. Find the letter Shin and click on it.

As soon as you click on the letter, its Unicode number shows up in the status bar. The Hebrew letter Shin is number 05E9. That's a hexadecimal number—"hex" for short.

You can convert it to decimal using the Windows calculator: open it up, put it in Scientific mode, click the "Hex" radio button, enter "05E9", and then click "Dec"—it's 1,513.

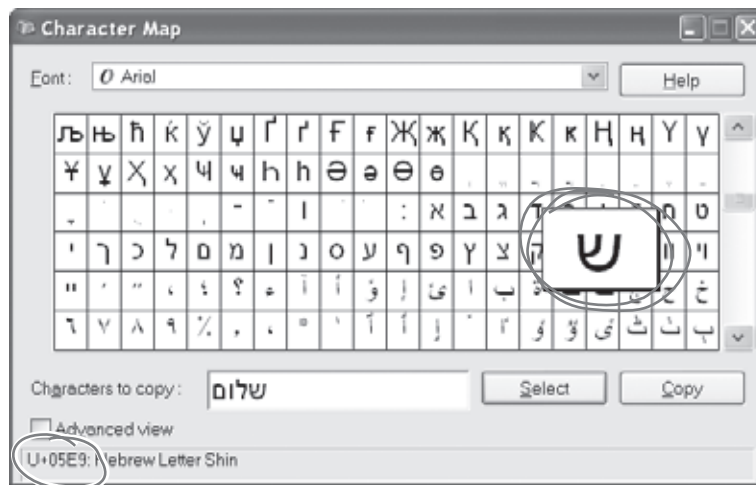

Unicode is an industry standard developed by a non-profit group called the Unicode Consortium, and it works across programs and different computer platforms. Take a minute and look at their website: <http://www.unicode.org/>

.NET converts text to Unicode automatically

The two C# value types for storing text—`string` and `char`—keep their data in memory as Unicode. When that data's written out as bytes to a file, each of those Unicode numbers is written out to the file. So start a new project and drag three buttons onto a form, and we'll use the `File.WriteAllBytes()` and `ReadAllBytes()` methods to get a sense of exactly how Unicode data is written out to a file.



1 Write a normal string out to a file and read it back

Use the same `WriteAllText()` method that you used in the text editor to have the first button write the string “Eureka!” out to a file called “eureka.txt”. Then create a new byte array called `eurekaBytes`, read the file into it, and then print out all of the bytes read:

```
File.WriteAllText("eureka.txt", "Eureka!");
byte[] eurekaBytes = File.ReadAllBytes("eureka.txt");
foreach (byte b in eurekaBytes)
    Console.Write("{0} ", b);
Console.WriteLine();
```

The `ReadAllBytes()` method returns a reference to a new array of bytes that contains all of the bytes that were read in from the file.

You'll see these bytes written to the output: 69 117 114 101 107 97 33. Now **open up the file in the Simple Text Editor** that you wrote earlier in the chapter. It says “Eureka!”

2 Make the second button display the bytes as hex numbers

It's not just Character Map that shows numbers in hex. Almost anything you read that has to do with encoding data will show that data in hex, so it's useful to know how to work with it. Make the code for second button's event handler in your program **identical to the first one**, except change the `Console.Write()` line so it looks like this instead:

```
Console.Write("{0:x2} ", b);
```

Hex uses the numbers 0 through 9 and letters A through F to represent numbers in base 16, so `6B` is equal to 107.

That tells `Write()` to print parameter #0 (the first one after the string to print) as a two-character hex code. So it writes the same seven bytes in hex instead of decimal: 45 75 72 65 6b 61 21

3 Make the third button write out Hebrew letters

Go back to Character Map and double-click on the Shin character (or click the Select button). It'll add it to the “Characters to copy” box. Then do the same for the rest of the letters in “Shalom”: Lamed (U+05DC), Vav (U+05D5), and Final Mem (U+05DD). Now add the code for the third button's event handler. It'll look exactly like button 2, except for one change. Click the “Copy” button in Character Map, and then paste the letters over “Eureka!” and add the `Encoding.Unicode` parameter, so it looks like this:

```
File.WriteAllText("eureka.txt", "שלום", Encoding.Unicode);
```

Did you notice that the IDE pasted the letters in **backwards**? That's because it knows that Hebrew is read right-to-left, so any time it encounters Hebrew Unicode letters, it displays them right-to-left. Put your cursor in the middle of the letters—the left and right arrow keys reversed! That makes it a lot easier if you need to type in Hebrew. Now run the code, and look closely at the output: ff fe e9 05 dc 05 d5 05 dd 05. The first two characters are “FF FE”, which is the Unicode way of saying that we're going to have a string of two-byte characters. The rest of the bytes are the Hebrew letters—but they're reversed, so U+05E9 appears as **e9 05**. Now open the file up in your Simple Text Editor—it looks right!

C# can use byte arrays to move data around

Since all your data ends up encoded as **bytes**, then it makes sense to think of a file as one **big byte array**. And you already know how to read and write byte arrays.

Here's the code to create a byte array, open an input stream, and read data into bytes 0 through 6 of the array.



```
byte[] greeting;  
greeting = File.ReadAllBytes(filename);
```

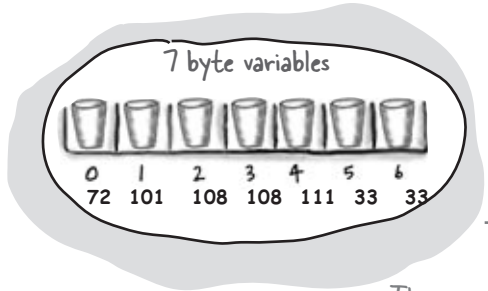

This is a static method for Arrays that reverses the order of the bytes. We're just using it to show that the changes you make to the byte array get written out to the file exactly.

```
Array.Reverse(greeting);  
File.WriteAllBytes(filename, greeting);
```

These numbers are the Unicode numbers for the characters in "Hello!!"



When the program writes the byte array out to a file, the text is in reverse order too.

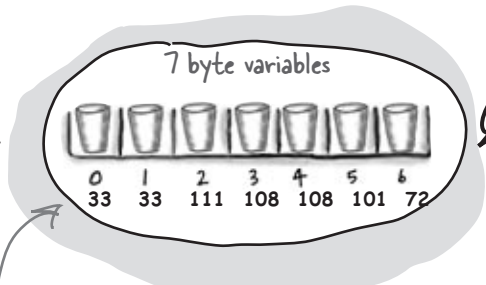

Now the bytes are in reverse order.

Use a BinaryWriter to write binary data

You *could* encode all of your strings, chars, ints, and floats into byte arrays before writing them out to files, but that would get pretty tedious. That's why .NET gives you a very useful class called **BinaryWriter** that **automatically encodes your data** and writes it to a file. All you need to do is create a FileStream and pass it into the BinaryWriter's constructor. Then you can call its methods to write out your data. So add another button to your program, and we'll show you how to use BinaryWriter().



- 1 Start by setting up some data to write to a file.

```
int intValue = 48769414;
string stringValue = "Hello!";
byte[] byteArray = { 47, 129, 0, 116 };
float floatValue = 491.695F;
char charValue = 'E';
```

If you use File.Create(), it'll start a new file—if there's one there already, it'll blow it away and start a brand new one. There's also the File.OpenWrite() method, which opens the existing one and starts overwriting it from the beginning.

- 2 To use a BinaryWriter, first you need to open a new stream with File.Create():

```
using (FileStream output = File.Create("binarydata.dat")) {
    BinaryWriter writer = new BinaryWriter(output);
```

- 3 Now just call its Write() method. Each time you do, it adds new bytes onto the end of the file that contain an encoded version of whatever data you passed it as a parameter.

```
writer.Write(intValue);
writer.Write(stringValue);
writer.Write(byteArray);
writer.Write(floatValue);
writer.Write(charValue);
}
```

Each Write() statement encodes one value into bytes, and then sends those bytes to the FileStream object. You can pass it any value type, and it'll encode it automatically.

The FileStream writes the bytes to the end of the file.

- 4 Now use the same code you used before to read in the file you just wrote.

```
byte[] dataWritten = File.ReadAllBytes("binarydata.dat");
foreach (byte b in dataWritten)
    Console.Write("{0:x2} ", b);
Console.WriteLine(" - {0} bytes", dataWritten.Length);
```

Write down the output in the blanks below. Can you **figure out what bytes correspond** to each of the five Write() statements? Mark each group of bytes with the name of the variable.

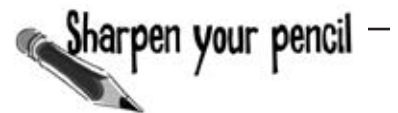

Here's a hint: Strings can be different lengths, so the string has to start with a number to tell .NET how long it is. Also, you can look up the string and char Unicode values using Character Map.

----- bytes

an amalgam of data

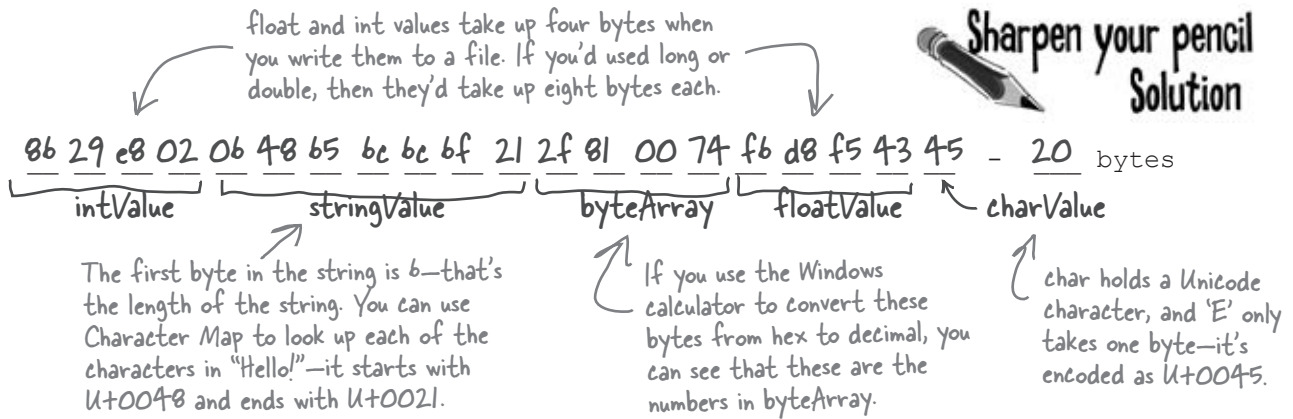

Use BinaryReader to read the data back in

The BinaryReader class works just like BinaryWriter. You create a stream, attach the BinaryReader object to it, and then call its methods. But the reader **doesn't know what data's in the file!** And it has no way of knowing. Your float value of 491.695F was encoded as d8 f5 43 45. But those same bytes are a perfectly valid int—1,140,185,334. So you'll need to tell the BinaryReader exactly what types to read from the file. Add one more button to your form, and have it read the data you just wrote.

Don't take our word for it. Replace the line that reads the float with a call to ReadInt32(). (You'll need to change the type of floatRead to int.) Then you can see for yourself what it reads from the file.

- 1 Start out by setting up the FileStream and BinaryReader objects:

```
using (FileStream input = File.OpenRead("binarydata.dat")) {  
    BinaryReader reader = new BinaryReader(input);
```

- 2 You tell BinaryReader what type of data to read by calling its different methods.

```
int intRead = reader.ReadInt32();  
string stringRead = reader.ReadString();  
byte[] byteArrayRead = reader.ReadBytes(4);  
float floatRead = reader.ReadSingle();  
char charRead = reader.ReadChar();
```

Each value type has its own method in BinaryReader() that returns the data in the correct type. Most don't need any parameters, but ReadBytes() takes one parameter that tells BinaryReader how many bytes to read.

- 3 You tell BinaryReader what type of data to read by calling its different methods.

```
Console.WriteLine("int: {0} string: {1} bytes: ", intRead, stringRead);  
foreach (byte b in byteArrayRead)  
    Console.WriteLine("{0} ", b);  
Console.WriteLine(" float: {0} char: {1} ", floatRead, charRead);  
}
```

Here's the output that gets printed to the console:

```
int: 48769414 string: Hello! bytes: 47 129 0 116 float: 491.695 char: E
```

You can read and write serialized files manually, too

Serialized files don't look so pretty when you open them up in Notepad. You'll find all the files you write in your project's "bin/Debug" folder—let's take a minute and get more acquainted to the inner workings of a serialized file.



1 Serialize two Card objects to different files

Use the serialization code you've already written to serialize the **Three of Clubs** to `card1.dat` and **Six of Hearts** to `card2.dat`. Check to make sure that both files were written out and are now in a folder, and that they both have the same file size. Then open one of them in Notepad:

There are some words in the file (like "Chapter9", which was the namespace we used), but it's mostly unreadable.

2 Write a loop to compare the two binary files

We used the `ReadByte()` method to read the next byte from a stream—it returns an `int` that contains the value of that byte. We also used the stream's `Length` field to make sure we read the whole file.

```
byte[] firstFile = File.ReadAllBytes("card1.dat");
byte[] secondFile = File.ReadAllBytes("card2.dat");
for (int i = 0; i < firstFile.Length; i++)
    if (firstFile[i] != secondFile[i])
        Console.WriteLine("Byte #{0}: {1} versus {2}",
            i, firstFile[i], secondFile[i]);
```

The two files are read into two different byte arrays, so they can be compared byte by byte. Since the same class was serialized to two different files, they'll be almost identical... but let's see just *HOW* identical they are.

This loop examines the first byte from each of the files and compares them, then the second byte, then the third, etc. When it finds a difference, it writes a line to the console.



Watch it!

When you write to a file, you don't always start from a clean slate!

Be careful if you use `File.OpenWrite()`. It doesn't delete the file—it just starts overwriting the data starting at the beginning. That's why we've been using `File.Create()`—it creates a new file.

—————▶ We're not done yet—flip the page!

Find where the files differ, and use that information to alter them

The loop you just wrote pinpoints exactly where the two serialized Card files differ. Since the only difference between the two objects were their Suit and Value fields, then that should be the only difference in their files, too. So if we find the bytes that hold the suit and value, we should be able to **change them to make a new card** with whatever suit and value we want!

3 Take a look at the console output to see how the two files differ

The console should show that two bytes differ:

```
Byte #218: 1 versus 3
Byte #266: 3 versus 6
```

That should make a lot of sense! Go back to the `Card.Suits` enum from the last chapter, and you'll find that value for Clubs is 1 and the value for Hearts is 3, so that's the first difference. And the second difference—six versus three—is pretty obviously the card's value. You might see different byte numbers, which isn't surprising: you might be using a different namespace, which would change the length of the file.

Remember how the namespace was included as part of the serialized file? If your namespace is different, then the byte numbers will be different too.

Hmm, if byte #218 in the serialized file represents the suit, then we should be able to change the suit of the card by reading that file in, changing that one byte, and writing it out again. (Remember, your own serialized file might store the suit at a different location.)

4 Write code to manually create a new file that contains King of Spades

We'll take one of the arrays that we read, alter it to contain a new card, and write it back out.

```
firstFile[218] = (byte) Card.Suits.Spades;
firstFile[266] = (byte) Card.Values.King;
File.Delete("card3.dat");
File.WriteAllBytes("card3.dat", firstFile);
```

If you found different byte numbers in step #3, substitute them in here.

Now **deserialize the card from card3.dat** and see if it's the King of Spades!

Now that you know which bytes contain the suit and value, you can change just those bytes in the array before it gets written out to `card3.dat`.

Working with binary files can be tricky

What do you do if you have a file and you aren't quite sure what's inside it? You don't know what application created it, and you need to know something about it—but when you open it in Notepad, it looks like a bunch of garbage. What if you'd exhausted all your other options, and really needed to just look inside? Looking at that picture, it's pretty clear that Notepad just isn't the right tool.

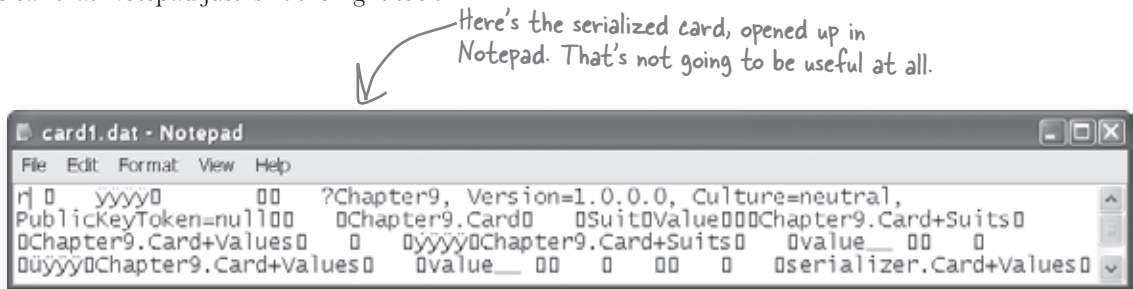

You can make out a few things—like the enum names (“Suit” and “Value”), and the name of the namespace we used (“Chapter9”). But that's not all that helpful.

There's another option—it's a format called a “hex dump”, and it's a pretty standard way to look at binary data. It's definitely more informative than looking at the file in Notepad. Hexadecimal—or “hex”—is a convenient way to display bytes in a file. Every byte takes 2 characters to display in hex, so you can see a lot of data in a really small space, and a format that makes it easy to spot patterns. Also, it's useful to display binary data in rows that are 8, 16, or 32 bytes long because most binary data tends to break down in chunks of 4, 8, 16, or 32...like all the types in C#. For example, an `int` takes up 4 bytes, and is 4 bytes long when serialized on disk. Here's what that same file looks like as a hex dump, using one of any number of free hex dump programs available for Windows:

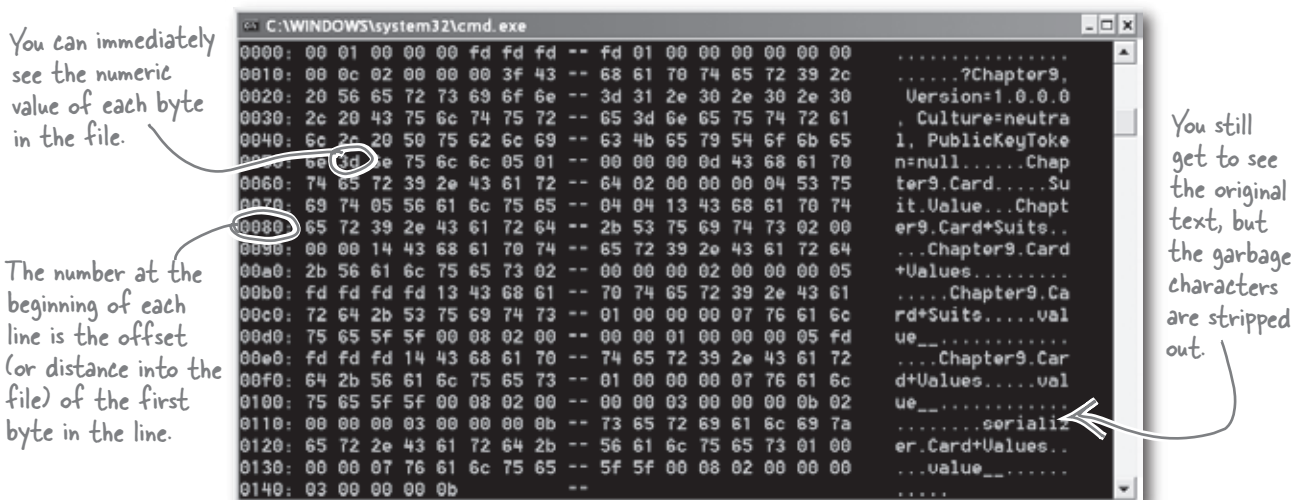

Use file streams to build a hex dumper

A **hex dump** is a *hexadecimal* view of the contents of a file, and it's a really common way for programmers to take a deep look at a file's internal structure. Most operating systems ship with a built-in hex dump utility. Unfortunately, Windows doesn't. So let's build one!

How to make a hex dump

Start with some familiar text:

```
We the people of the United States, in order to form a more perfect union...
```

Here's what a hex dump of that text would look like:

Again, you can immediately see the numeric value of each byte in the file.

```
0000: 57 65 20 74 68 65 20 70 -- 65 6f 70 6c 65 20 6f 66
0010: 20 74 68 65 20 55 6e 69 -- 74 65 64 20 53 74 61 74
0020: 65 73 2c 20 69 6e 20 6f -- 72 64 65 72 20 74 6f 20
0030: 66 6f 72 6d 20 61 20 6d -- 6f 72 65 20 70 65 72 66
0040: 65 63 74 20 75 6e 69 6f -- 6e 2e 2e 2e
```

```
We the people of
 the United Stat
es, in order to
form a more perf
ect union...
```

We'll add the number at the beginning of each line by using the offset of the first byte in the line.

And we'll need to replace the garbage characters with periods.

Each of those numbers—57, 65, 6F—is the value of one byte in the file. The reason some of the “numbers” have letter values is that they're *hexadecimal* (or hex). That's just another way of writing a number. Instead of using ten digits from 0 to 9, it uses sixteen digits from 0 to 9 plus the letters A through F.

Each line in our hex dump represents sixteen characters in the input that was used to generate it. In our dump, the first four characters are the offset in the file—the first line starts at character 0, the next at character 16 (or hex 10), then character 32 (hex 20), etc. (Other hex dumps look slightly different, but this one will do for us.)

Working with hex

You can put hex numbers directly into your program—just add the characters 0x in front of the number:

```
int j = 0x20;
MessageBox.Show("The value is " + j);
```

When you use the + operator to concatenate a number into a string, it gets converted to decimal. You can use the static `String.Format()` method to convert your number to a hex-formatted string instead:

```
string h = String.Format("{0:x2}", j);
```

`String.Format()` uses parameters just like `Console.WriteLine()`, so you don't need to learn anything new to use it.

StreamReader and StreamWriter will do just fine

Our hex dumper will write its dump out to a file, and since it's just writing text a StreamWriter will do just fine. But we can also take advantage of the **ReadBlock()** method in StreamReader. It reads a block of characters into a char array—you specify the number of characters you want to read, and it'll either read that many characters or, if there are fewer than that many left in the file, it'll read the rest of the file. Since we're displaying 16 characters per line we'll read blocks of 16 characters.

So add one more button to your program—add this hex dumper to it. Change the first two lines so that they point to real files on your hard drive. Start with a serialized Card file. Then see if you can modify it to use the Open and Save As dialog boxes.

The reason the method's called "ReadBlock()" is that when you call it, it "blocks" (which means it keeps executing and doesn't return to your program) until it's either read all the characters you asked for or run out of data to read.

```
using (StreamReader reader = new StreamReader(@"c:\files\inputFile.txt"))
using (StreamWriter writer = new StreamWriter(@"c:\files\outputFile.txt", false))
{
    int position = 0;
    while (!reader.EndOfStream) {
        char[] buffer = new char[16];
        int charactersRead = reader.ReadBlock(buffer, 0, 16);
        writer.Write("{0}: ", String.Format("{0:x4}", position));
        position += charactersRead;
        for (int i = 0; i < 16; i++) {
            if (i < charactersRead) {
                string hex = String.Format("{0:x2}", (byte)buffer[i]);
                writer.Write(hex + " ");
            }
            else
                writer.Write("  ");
            if (i == 7) { writer.Write("-- "); }
            if (buffer[i] < 32 || buffer[i] > 250) { buffer[i] = '.'; }
        }
        string bufferContents = new string(buffer);
        writer.WriteLine("  " + bufferContents.Substring(0, charactersRead));
    }
}
```

A StreamReader's **EndOfStream** field returns false if there are characters still left to read in the file.

This **ReadBlock()** call reads up to 16 characters into a char array.

The static **String.Format** method converts numbers to strings. "{0:x4}" tells **Format()** to print the second parameter—in this case, **position**—as a 4-character hex number.

This loop goes through the characters and prints each of them to a line in the output.

Some characters with a value under 32 don't print, so we'll replace all of them with a period.

You can convert a **char[]** array to a string by passing it to the overloaded constructor for **string**.

The hex dumper works just fine for text files. But there's a problem. Use **File.WriteAllBytes()** to write an array of bytes with values over 127 to a file and then run it through your dumper. Uh-oh — they're all read in as "fd"! That's because **StreamReader** is built to read text files, which only contain bytes with values under 128.

Every string has a **substring** method that returns a piece of the string. In this case, it returns the first **charactersRead** characters starting at the beginning (position 0). (Look back at the top of the loop to see where **charactersRead** is set—the **ReadBlock()** method returns the number of characters that it read into the array.

Here's a **bonus exercise**: See if you can figure out how to use the **BinaryReader** class to fix the problem!

there are no Dumb Questions

Q: Why didn't I have to use the `Close()` method to close the file after I used `File.ReadAllText()` and `File.WriteAllText()`?

A: The `File` class has several very useful static methods that automatically open up a file, read or write data, and then close it automatically. In addition to the `ReadAllText()` and `WriteAllText()` methods, there are `ReadAllBytes()` and `WriteAllBytes()` that work with byte arrays, and `ReadAllLines()` and `WriteAllLines()`, which read and write string arrays, where each string in the array is a separate line in the file. All of these methods automatically open and close the streams, so you can do your whole file operation in a single statement.

Q: If the `FileStream` has methods for reading and writing, why do I ever need to use `StreamReader` and `StreamWriter`?

A: The `FileStream` class is really useful for reading and writing bytes to binary files. Its methods for reading and writing operate with bytes and byte arrays. But a lot of programs work exclusively with text files—like the first version of the Excuse Generator, which only wrote strings out to files. That's where the `StreamReader` and `StreamWriter` come in really handy. They have methods that are built specifically for reading and writing lines of text. Without them, if you wanted to read a line of text in from a file, you'd have to first read a byte array and then write a loop to search through that array for a linebreak—so it's easy to see how they make your life easier.

Q: When should I use `File`, and when should I use `FileInfo`?

A: The main difference between the `File` and `FileInfo` classes is that the methods in `File` are static, so you don't need to create an instance of them. On the other hand, `FileInfo` requires that you instantiate it with a filename. In some cases, that would be more cumbersome, like if you only need to perform a single file operation (like just deleting or moving one file). On the other hand, if you need to do many file operations to the same file, then it's more efficient to use `FileInfo`, because you only need to pass it the filename once. You should decide which one to use based on the particular situation you encounter. In other words, if you're doing one file operation, use `File`. If you're doing a lot of file operations in a row, use `FileInfo`.

Q: Back up a minute. Why was "Eureka!" written out with one byte per character, but when I wrote out the Hebrew letters they took up two bytes? And what was that "FF FE" thing at the beginning of the bytes?

A: What you're seeing is the difference between two closely related Unicode encodings. Plain English letters, numbers, normal punctuation marks, and some standard characters (like curly brackets, ampersands, and other things you see on your keyboard) all have very low Unicode numbers—between 0 and 127. (If you've used ASCII before, they're the same as the ASCII characters.) If a file only contains those Unicode characters with low numbers, it just prints out their bytes.

Things get a little more complicated when you add higher-numbered Unicode characters into the mix. One byte can only hold a number between 0 and 255. But two bytes in a row can store numbers between 0 and 65,536—which, in hex, is FFFF. The file needs to be able to tell whatever program opens it up that it's going to contain these higher-numbered characters. So it puts a special reserved byte sequence at the beginning of the file: "FF FE". That's called the "byte order mark". As soon as a program sees that, it knows that all of the characters are encoded with two bytes each. (So an E is encoded as 00 45—with leading zeroes.)

Q: Why is it called a byte order mark?

A: Remember how your bytes were reversed? Shin's Unicode value of U+05E9 was written to the file as E9 05. That's called "little endian". Go back to the code that wrote out those bytes and change the third parameter to `WriteAllText()`: `Encoding.BigEndianUnicode`. That tells it to write the data out in "big endian", which doesn't flip the bytes around. You'll see the bytes come out as "05 E9" this time. You'll also see a different byte order mark: "FE FF". And your Simple Text Editor is smart enough to read both of them!

If you're writing a string that only has Unicode characters with low numbers, it writes one byte per character. But if it's got high-numbered characters, they'll be written using two or more bytes each.

↑
This encoding is called UTF-8, which .NET uses by default. You can tell `File.WriteAllText()` to use a different encoding by passing it a different `Encoding` object. You can learn more about Unicode encodings at <http://unicode.org>.



Exercise

Change Brian's Excuse Generator so it uses binary files with serialized Excuse objects instead of text files.

- 1 **Make the Excuse class serializable**
Mark the Excuse class with the [Serializable] attribute to make it serializable. Also, you'll need to add the using line:
`using System.Runtime.Serialization.Formatters.Binary;`
- 2 **Change the Excuse.Save() method to serialize the excuse**
When the Save() method writes a file out to the folder, instead of using StreamWriter to write the file out, have it open a file and serialize itself out. You'll need to figure out how the current class can deserialize itself.
- 3 **Change the Excuse.OpenFile() method to deserialize an excuse**
You'll need to create a temporary Excuse object to deserialize from the file, and then copy its fields into the current class.
- 4 **Now just change the form so it uses a new file extension**
There's just one very small change you need to make to the form. Since we're no longer working with text files, we shouldn't use the .txt extension any more. Change the dialog boxes, default filenames and directory search code so that they work with *.excuse files instead.

Hint: What keyword can you use inside of a class that returns a reference to itself?

Wow, that was really easy! All the code for saving and opening excuses was inside the Excuse class. I just had to change the class—I barely had to touch the form at all. It's like the form doesn't even care how the class saves its data. It just passes in the filename and knows everything will get saved properly.



That's right! Your code was very easy to change because the class was well encapsulated.

When you've got a class that hides its internal operations from the rest of the program and only exposes the behavior that needs to be exposed, it's called a **well encapsulated class**. In the Excuse Manager program, the form doesn't have any information about how excuses are saved to files. It just passes a filename into the excuse class, and the class takes care of the rest. That makes it very easy to make big changes to how your class works with files. The better you encapsulate your classes, the easier they are to alter later on.

Remember how encapsulation was one of the four core OOP principles? Here's an example of how using those principles makes your programs better.



Exercise Solution

Change Brian's Excuse Generator so it uses binary files with serialized Excuse objects instead of text files.

You only need to change these three statements in the form: two in the save button's Click event, and one in the open button's—they just change the dialogs to use the .excuse extension, and set the default save filename.

```
private void save_Click(object sender, EventArgs e) {
    // existing code
    saveFileDialog1.Filter = "Excuse files (*.excuse)|*.excuse|All files (*.*)|*.*";
    saveFileDialog1.FileName = description.Text + ".excuse";
    // existing code
}

private void open_Click(object sender, EventArgs e) {
    // existing code
    openFileDialog1.Filter =
        "Excuse files (*.excuse)|*.excuse|All files (*.*)|*.*";
    // existing code
}

[Serializable]
public class Excuse {
    public string Description;
    public string Results;
    public DateTime LastUsed;
    public string ExcusePath;

    public Excuse() {
        ExcusePath = "";
    }

    public Excuse(string excusePath) {
        OpenFile(ExcusePath);
    }

    public Excuse(Random random, string folder) {
        string[] fileNames = Directory.GetFiles(folder, "*.excuse");
        OpenFile(fileNames[random.Next(fileNames.Length)]);
    }

    private void OpenFile(string excusePath) {
        this.ExcusePath = excusePath;
        BinaryFormatter formatter = new BinaryFormatter();
        Excuse tempExcuse;
        using (Stream input = File.OpenRead(excusePath)) {
            tempExcuse = (Excuse)formatter.Deserialize(input);
        }
        Description = tempExcuse.Description;
        Results = tempExcuse.Results;
        LastUsed = tempExcuse.LastUsed;
    }

    public void Save(string fileName) {
        BinaryFormatter formatter = new BinaryFormatter();
        using (Stream output = File.OpenWrite(fileName)) {
            formatter.Serialize(output, this);
        }
    }
}
```

Standard save and open dialog boxes do the trick here.

The only change to the form is to have it change the file extension it passes to the Excuse class.

The constructor for loading random excuses needs to look for the ".excuse" extension instead of "*.txt" files.

We pass in "this" because we want this class to be serialized.



Filecross

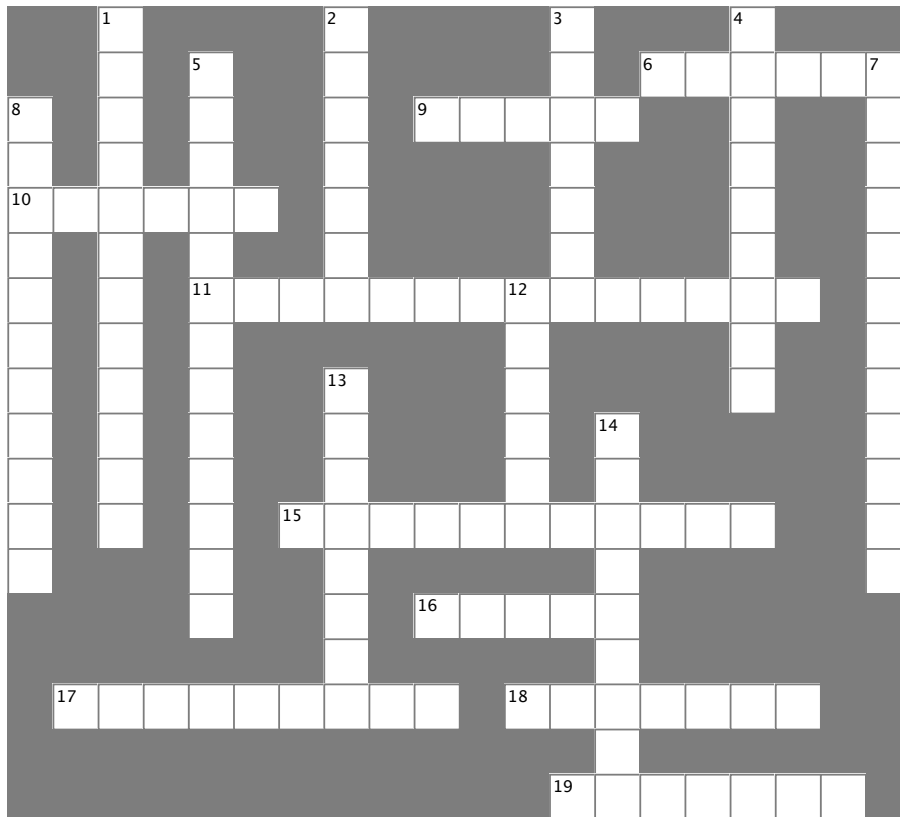

Across

6. The method in the File class that checks whether or not a specific file is on the drive
9. This statement indicates the end of a case inside a switch statement
10. The abstract class that FileStream inherits from
11. A non-visual control that lets you pop up the standard Windows "Save As" dialog box
15. How you write numbers in base-16
16. If you don't call this method, your stream could be locked open so other methods or programs can't open it
17. The StreamReader method that reads data into a char[] array
18. An encoding system that assigns a unique number to each character
19. Use this statement to indicate which statements should be executed when the value being tested in a switch statement does not match any of the cases

Down

1. This class has a method that writes any value type to a file
2. The static method in the Array class that turns an array backwards
3. The event handler that gets run whenever someone modifies the data in an input control
4. This class has many static methods that let you manipulate folders
5. Using this OOP principle makes it a lot easier to maintain your code
7. If you don't use this attribute to indicate that a class can be written to a stream, BinaryFormatter will generate an error
8. This BinaryFormatter method reads an object from a stream
12. \n and \r are examples of this kind of sequence
13. This class lets you perform all the operations in the File class for a specific file
14. This method sends text to a stream followed by a line break

10 exception handling

Putting out fires gets old ✨

Good thing I wrote code to handle my HangoverException.



Programmers aren't meant to be firefighters.

You've worked your tail off, waded through technical manuals and a few engaging Head First books, and you've reached the pinnacle of your profession: **master programmer**. But you're still getting pages from work because **your program crashes, or doesn't behave like it's supposed to**. Nothing pulls you out of the programming groove like having to fix a strange bug...but with **exception handling**, you can write code to **deal with problems** that come up. Better yet, you can even react to those problems, and **keep things running**.

Brian needs his excuses to be mobile

Brian recently got reassigned to the international division. Now he flies all over the world. But he still needs to keep track of his excuses, so he installed the program you built on his laptop, and takes it with him everywhere.

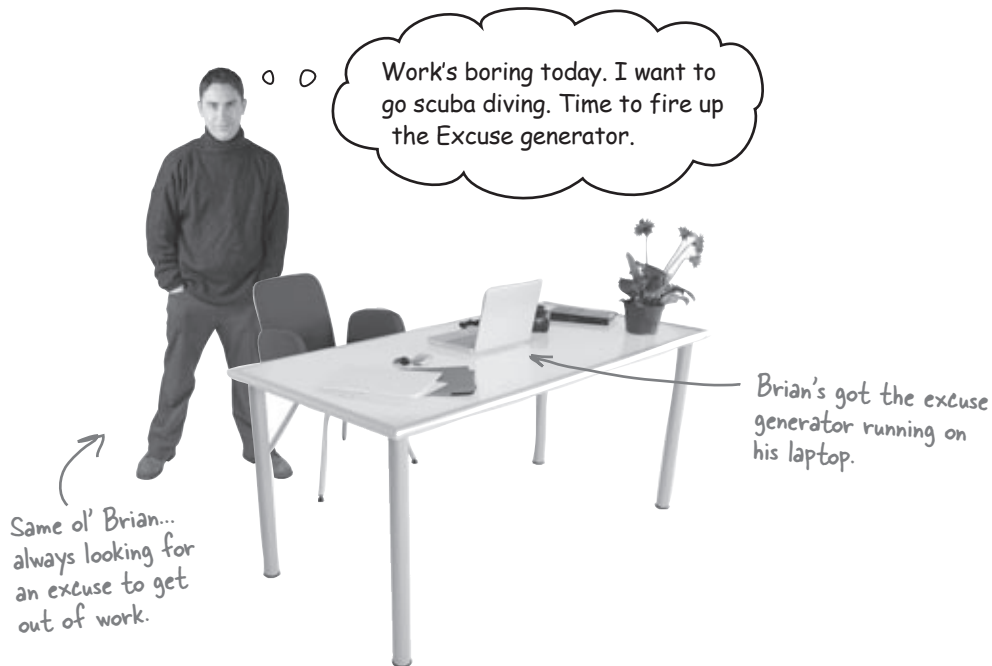

But the program isn't working!

Brian clicks the "Random Excuse" button, and gets a pretty nasty looking error. Something about not finding his excuses. What gives?



Sharpen your pencil



Here's another example of some broken code. There are five different exceptions that this code throws, and the error messages are shown on the right. It's your job to match the line of code that has a problem with the exception that line generates. Read the exception messages for a good hint.

```
public static void BeeProcessor() {
    object myBee = new HoneyBee(36.5, "Zippo");
    float howMuchHoney = (float)myBee;

    HoneyBee anotherBee = new HoneyBee(12.5, "Buzzy");
    double beeName = double.Parse(anotherBee.MyName);

    double totalHoney = 36.5 + 12.5;
    string beesWeCanFeed = "";
    for (int i = 1; i < (int) totalHoney; i++) {
        beesWeCanFeed += i.ToString();
    }
    float f =
        float.Parse(beesWeCanFeed);

    int drones = 4;
    int queens = 0;
    int dronesPerQueen = drones / queens;

    anotherBee = null;
    if (dronesPerQueen < 10) {
        anotherBee.DoMyJob();
    }
}
```

Calling `double.Parse("32")` will parse a string and return a double value, like 32.

1 **OverflowException was unhandled**
Value was either too large or too small for a Single.

2 **NullReferenceException was unhandled**
Object reference not set to an instance of an object.

3 **InvalidCastException was unhandled**
Specified cast is not valid.

4 **DivideByZeroException was unhandled**
Attempted to divide by zero.
Troubleshooting tips:
Make sure the value of the denominator is not zero before performing a division operation.
Get general help for this exception.
Search for more Help Online...

5 **FormatException was unhandled**
Input string was not in a correct format.
Troubleshooting tips:
Make sure your method arguments are in the right format.
When converting a string to DateTime, parse the string to take the date before putting each variable into the DateTime object.
Get general help for this exception.
Search for more Help Online...

When you have a reference that doesn't point to any object, it gets a special value called null. Setting a reference to null, tells C# it doesn't point to anything.

Sharpen your pencil Solution

Your job was to match the line of code that has a problem with the exception that line generates.

```
object myBee = new HoneyBee(36.5, "Zippo");
float howMuchHoney = (float)myBee;
```

C# has no idea how to cast a HoneyBee object to a float, and trying to do it will cause an `InvalidCastException`.



```
HoneyBee anotherBee = new HoneyBee(12.5, "Buzzy");
double beeName = double.Parse(anotherBee.MyName);
```

The `Parse()` method wants you to give it a string in a certain format. "Buzzy" isn't a string it knows how to convert to a number. That's why it throws a `FormatException`.

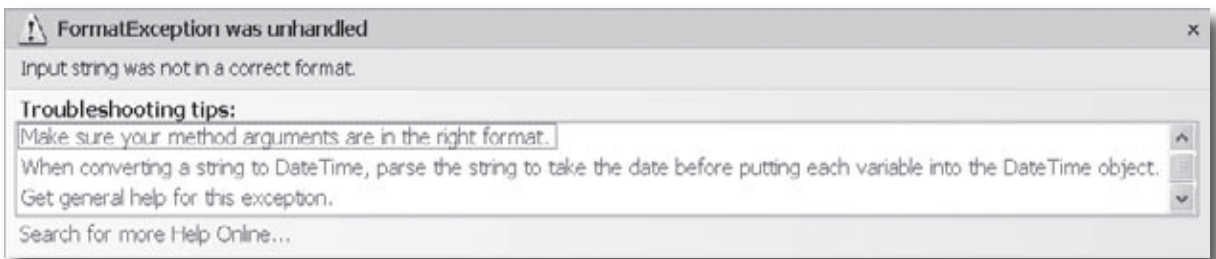

```
double totalHoney = 36.5 + 12.5;
string beesWeCanFeed = "";
for (int i = 1; i < (int) totalHoney; i++) {
    beesWeCanFeed += i.ToString();
}
float f = float.Parse(beesWeCanFeed);
```

The for loop will create a string called `beesWeCanFeed` that contains a number with over 60 digits in it. There's no way a float can hold a number that big, and trying to cram it into a float will throw an `OverflowException`.

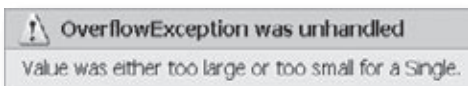

You'd never actually get all these exceptions in a row. The program would throw the first exception and then stop. You'd only get to the second exception if you fixed the first.

```
int drones = 4;
int queens = 0;
int dronesPerQueen = drones / queens;
```

It's really easy to throw a `DivideByZeroException`. Just divide any number by zero.

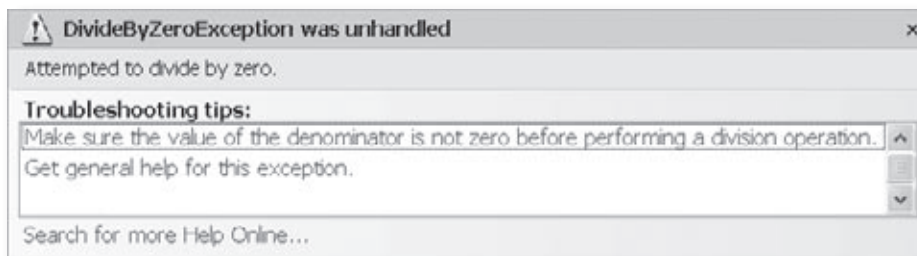

Dividing any number by zero always throws this kind of exception. Even if you don't know the value of `queens`, you can prevent it just by checking the value to make sure it's not zero **before** you divide it into `drones`.

```
anotherBee = null;
if (dronesPerQueen < 10) {
    anotherBee.DoMyJob();
}
```

Setting the `anotherBee` reference variable equal to `null` tells C# that it doesn't point to anything. So instead of pointing to an object, it points to nothing. Throwing a `NullReferenceException` is C#'s way of telling you that there's no object whose `DoMyJob()` method can be called.



That `DivideByZero` error didn't have to happen. You can see just by looking at the code that there's something wrong. The same goes for the other exceptions. These problems were preventable—and the more you know about exceptions, the better you'll be at keeping your code from crashing.

When your program throws an exception, .NET generates an Exception object.

You've been looking at .NET's way of telling you something went wrong in your program: an **exception**. In C#, when an exception occurs, an object is created to represent the problem. It's called, no surprise here, `Exception`.

For example, suppose you have an array with four items. Then, you try and access the sixteenth item (index 15, since we're zero-based here):

```
int anArray[] = {3, 4, 1, 11};
int aValue = anArray[15];
```

This code is obviously going to cause problems.

ex-cep-tion, noun. a person or thing that is excluded from a general statement or does not follow a rule. *While Jim usually hates peanut butter, he made an **exception** for Ken's peanut butter fudge.*

As soon as your program runs into an unhandled exception, it generates an object with all the data it has about it.



You can see this detail by clicking on the View Detail link in the unhandled exception window.

The exception object has a message that tells you what's wrong and a list of all of the calls that were made to the system's memory leading up to the event that caused the exception.

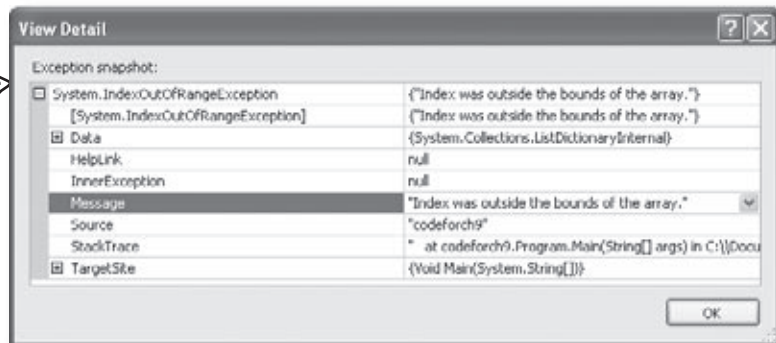

.NET goes to the trouble of creating an object because it wants to give you all the information about what caused the exception. You may have code to fix, or you may just need to make some changes to how you handle a particular situation in your program.

In this case, an **IndexOutOfRangeException** indicates you have a bug: you're trying to access an index in the array that's out of range. You've also got information about exactly where in the code the problem occurred, making it easy to track down the problem (even if you've got thousands of lines of code).

there are no Dumb Questions

Q: Why are there so many kinds of exceptions?

A: There are all sorts of ways that you can write code that C# simply doesn't know how to deal with. It would be difficult to troubleshoot your problems if your program simply gave a generic error message ("A problem occurred at line 37"). It's a lot easier to track down and fix problems in your code when you know specifically what kind of error occurred.

Q: So what *is* an exception, really?

A: It's an object that .NET creates when there's a problem (more about that in a minute).

Q: Wait, what? It's an *object*?

A: Yes, an exception is an **object**. The properties in the object tell you information about the exception. For example, it's got a `Message` property that has a useful string like "Specified cast was invalid" and "Value was either too large or too small for a Single", which is what it used to generate the exception window. The reason that .NET generates it is to give you as much information as it can about exactly what was going on when it executed the statement that threw the exception.

Q: Okay, I still don't get it. Sorry. Why are there so many different kinds of exceptions, again?

A: Because there are so many ways that your code can act in unexpected ways. There are a lot of situations that will cause your code to simply crash. It would be really hard to troubleshoot the problems if you didn't know why the crash happened. By throwing different kinds of exceptions under different circumstances, .NET is giving you a lot of really valuable information to help you track down and correct the problem.

Q: So exceptions are there to help me, not just cause a pain in my butt?

A: Yes! Exceptions are all about helping you expect the unexpected. A lot of people get frustrated when they see code throw an exception. But if you think about an exception as .NET's way of helping you track down and debug your program, it really helps out when you're trying to track down what's causing the code to bomb out.

Q: So when my code throws an exception, it's not necessarily because I did something wrong?

A: Exactly. Sometimes your data's different than you expected it to be—like you've got a method that's dealing with an array that's a lot longer or shorter than you anticipated when you first wrote it. And don't forget that human beings are using your program, and they almost always act in an unpredictable way. Exceptions are .NET's way to help you handle those unexpected situations so that your code still runs smoothly and doesn't simply crash or give a cryptic, useless error message.

Q: Once I knew what I was looking for, it was pretty clear that the code on the previous page was going to crash. Are all exceptions easy to spot?

A: No. Unfortunately, there are times when your code will have problems, and it'll be really hard to figure out what's causing them just by looking at it. That's why the IDE gives you a really useful tool called the **debugger**. It lets you pause your program and execute it statement by statement, inspecting the value of each individual variable and field as you go. That makes it a lot easier for you to figure out where your code is acting in a way that's different from how you expect it to act. That's when you have the best chance of finding and fixing the exceptions—or, even better, preventing them in the first place.

Exceptions are all about helping you find and fix situations where your code behaves in ways you didn't expect.

Brian's code did something unexpected

When Brian wrote his excuse manager, he never expected the user to try to pull a random excuse out of an empty directory.

- 1 The problem happened when Brian pointed his Excuse Manager program at an empty folder on his laptop and clicked the Random button. Let's take a look at it and see if we can figure out what went wrong. Here's the unhandled exception window that popped up when he ran the program outside the IDE:

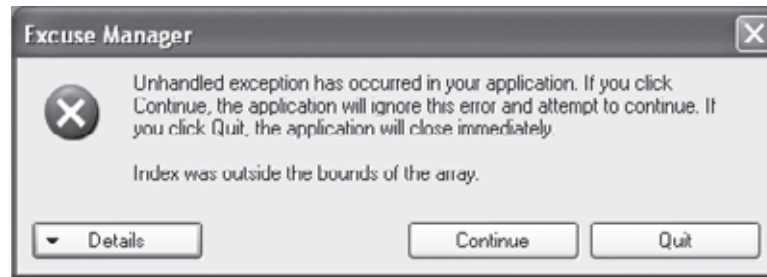

- 2 Okay, that's a good starting point. It's telling us that the index was outside the bounds of the array, right? So let's look for an array in the code for the Random Excuse button's event handler:

```
private void RandomExcuseButton_Click(object sender, EventArgs e) {  
    if (CheckChanged() == true) {  
        CurrentExcuse = new Excuse(random, Folder);  
        UpdateForm(false);  
    }  
}
```

- 3 Hmm, no arrays in there. But it creates a new Excuse object using one of the overloaded constructors. Maybe there's an array in the constructor code:

```
public Excuse(Random random, string Folder) {  
    string[] fileNames = Directory.GetFiles(Folder, "*.excuse");  
    OpenFile(fileNames[random.Next(fileNames.Length)]);  
}
```

Bingo! There's the array. We must be trying to use an index that's past the end of the array.

4

It turns out that `Directory.GetFiles()` returns an empty array when you point it at a directory with no files in it. Hey, we can test for that! All we need to do is add a check to **make sure the directory's not empty** before we open a file, and the nasty unhandled exception window will be replaced with an informative message box.

```
private void RandomExcuseButton_Click(object sender, EventArgs e) {
    string[] fileNames = Directory.GetFiles(selectedFolder, "*.excuse");
    if (fileNames.Length == 0) {
        MessageBox.Show("Please specify a folder with excuse files in it",
            "No excuse files found");
    } else {
        if (CheckChanged() == true) {
            CurrentExcuse = new Excuse(random, Folder);
            UpdateForm(false);
        }
    }
}
```

By checking for excuse files in the folder before we create the `Excuse` object, we can prevent the exception from being thrown—and pop up a helpful message box, too.

Oh, I get it. Exceptions aren't always bad. Sometimes they identify bugs, but a lot of the time they're just telling me that something happened that was different from what I expected.



That's right. Exceptions are a really useful tool that you can use to find places where your code acts in ways you don't expect.

A lot of programmers get frustrated the first time they see an exception. But exceptions are really useful, and you can use them to your advantage. When you see an exception, it's giving you a lot of clues to help you figure out when your code is reacting to a situation that you didn't anticipate. And that's good for you: it lets you know about a new scenario that your program has to handle, and it gives you an opportunity to **do something about it**.

All exception objects inherit from Exception

.NET has lots of different exceptions it may need to report. Since many of these have a lot of similar features, inheritance comes into play. .NET defines a base class, called Exception, that all specific exceptions types inherit from.

The Exception class has a couple of useful members. The Message property stores an easy-to-read message about what went wrong. And StackTrace tells you what was going on in memory when the exception occurred, and what led up to the exception. (There are others, too, but we'll use those first.)

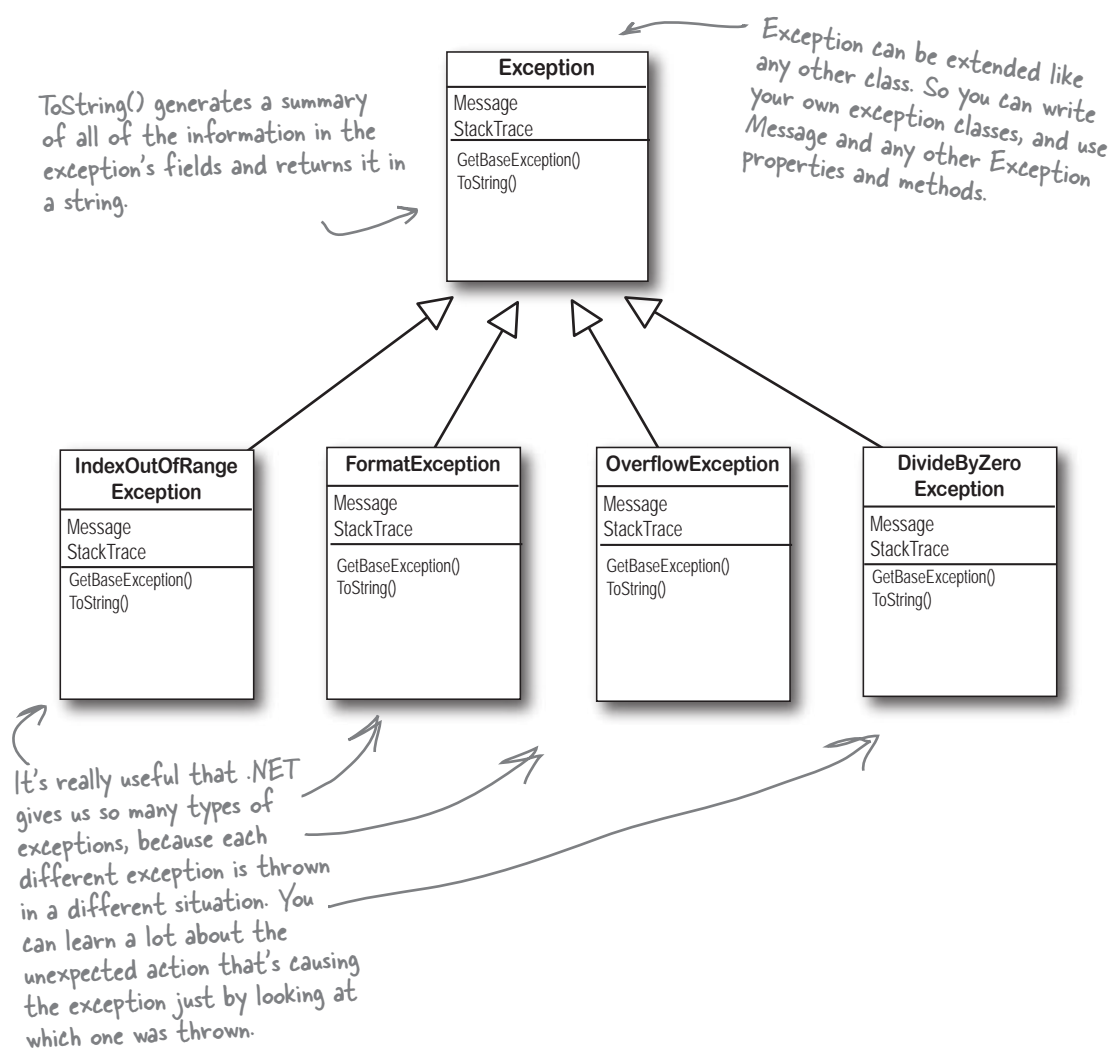

The debugger helps you track down and prevent exceptions in your code

Before you can add exception handling to your program, you need to know which statements in your program are throwing the exception. That's where the **debugger** that's built into the IDE can be really helpful. When you run the debugger, the IDE pops up a toolbar with some really useful buttons. Take a minute and hover your mouse cursor over each of them to see its name and shortcut key. (Those shortcut keys come in really handy.)

The Debug toolbar only shows up when you're debugging your program in the IDE. So you'll have to run a program in order to hover over the toolbar icons.

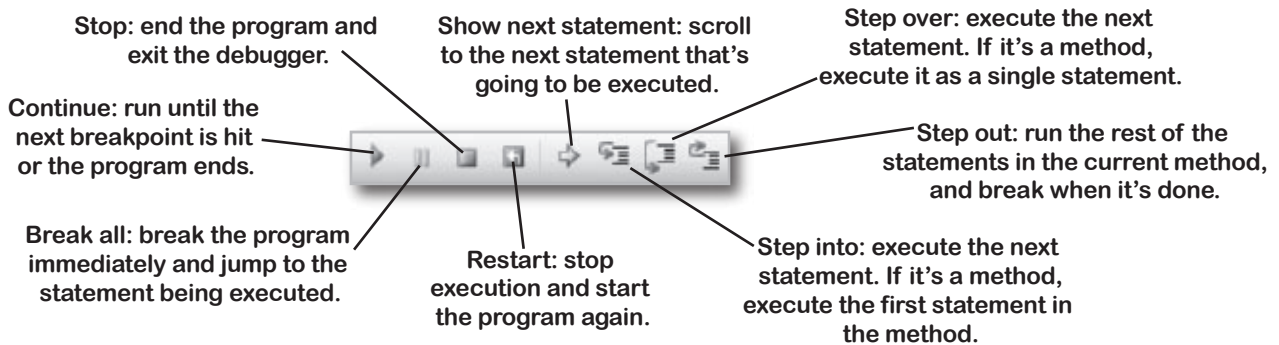

Debugging means running your code line by line to see what happens

Whenever you run your program inside the IDE, you can always pause it at any time by hitting the **Break All** button in the toolbar (or choosing the command from the Debug menu). This causes your program to **stop in its tracks** and show you the line of code that it's about to run. It turns that line of code yellow to show you that it's the one that'll run next. If you press **Continue**, then your program will keep running as if you'd never stopped it. But you can also step through your code, which means executing the current line and going to the next one. If the next line is a method, then you can **step into** the method, which causes the debugger to jump to the first line of the method and highlight it. Or you can **step over** the method, which executes the whole thing. If you're inside a method, you can **step out** of it, which causes the debugger to execute the rest of the statements in the method and break at the first line after it returns from the method.

You can also inspect and change variables and fields in your code using the **Watch window**. Just right-click on a variable in the code and select "Add Watch", and it'll appear in the Watch window—or you can type it directly into the Watch window. Then its value will be displayed. If it's an object, you can drill down into its fields.

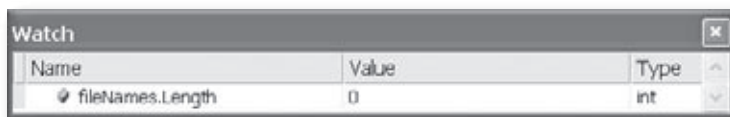

When you break inside the debugger, the IDE stops your program and displays the next line of code that it's about to run highlighted in yellow. Then you can move forward line by line until you find your problem.

Use the IDE's debugger to ferret out exactly what went wrong in the excuse manager

Let's use the debugger to take a closer look at the problem that we ran into in the excuse manager. It's a good place to get some practice with the debugger, because you know exactly what you're looking for. (That's a luxury that you don't have most of the time!)

1 Use a breakpoint to break—or pause—your program

You've got a starting point—the exception happens when the Random Excuse button is clicked after an empty folder is selected. So open up the code for the button, click anywhere in the first line of the method, and select “Toggle Breakpoint” from the Debug menu (or press F9):

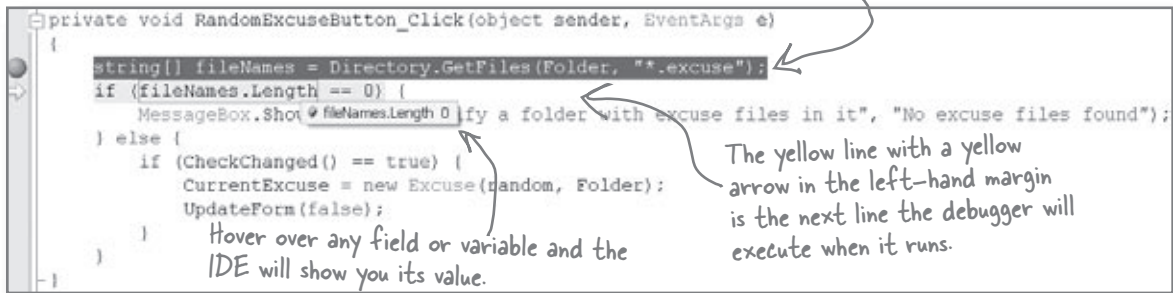

The IDE turned the line red and put a circle in the left-hand margin. That's the debugger's way of telling you that it set a **breakpoint** on the line. Now, when you debug the program in the IDE, execution will stop on that line. Give it a try—run the program in the IDE (using the same “Start Debugging” command you've been using all along). When you reproduce the problem, the line should turn yellow, with an arrow pointing to the code. Now your program's temporarily paused. The “Start Debugging” menu item's turned into “Continue Debugging,” too. Click it—the program will pick up exactly where it left off, starting with the line you put the breakpoint on.

Now you know why the IDE command for running a program is “Start Debugging”—because you're using the debugger built into the IDE.

Start Debugging — when you have no breakpoints set — is the same as running your program.

2 Step through the application

Use the **Step Into** command (using either the toolbar or the F11 key) to move through the application line by line. When it gets to the line that creates the new `Excuse` object, it'll jump straight into the constructor that you fixed. Step past the first line so it sets the `fileNames` variable. Then hover over the variable to see its value.

3 Use the Watch window to reproduce the problem

One really powerful feature of the debugger is the **Watch** window, which lets you check the value of variables and fields in your objects. Hover your mouse cursor over the “Length” part of `fileNames.Length`. Then select all of `fileNames.Length`, right-click, and select “Add Watch” from the menu. It’ll get added to the Watch window (which is in the same pane as Output—you can bring it up by selecting “Watch” under Windows in the Debug menu). Then add each piece of the statement: first `random.Next(fileNames.Length)`. It should look something like this, depending on how many files are in the folder you pointed to—in this case, we had five, so `fileNames` has five elements:

We’ll use the Watch window to reproduce the problem that caused the exception. We’ll start by adding the `fileNames` array.

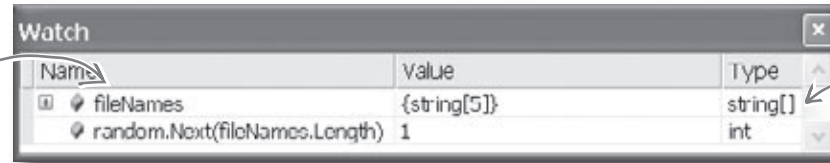

You need to break (pause) the program before you can add a watch.

4 Set fileNames equal to an empty string array

Double-click in the empty space in the Watch window underneath the two watch variables. You’ll get a cursor. Type this in: `fileNames = new string[0]`. Watch the top row in the window—as soon as you hit enter, the value of `fileNames` will change to `{string[0]}`. A re-evaluate icon (⌚) should show up next to the `random.Next` line—click on it and its value gets set to 0. So what happened?

The Watch window has another very useful feature—it lets you **change the value** of variables and fields that it’s displaying. And it even lets you **execute methods and create new objects**—and when you do, it displays its re-evaluate icon (⌚) that you can click to tell it to execute that line again, because sometimes running the same method twice will generate different results (like with `Random`).

We know the problem happened with an empty `fileNames` array, so we’ll use the Watch window to change its value to an empty string array.

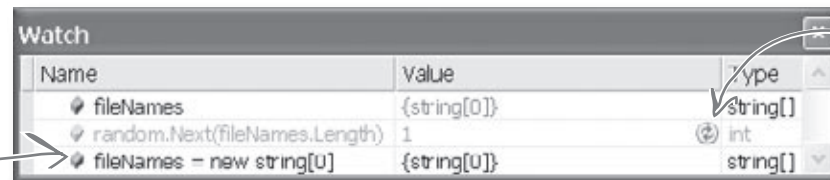

This icon tells the Watch window to reevaluate the `Next()` method.

5 Reproduce the problem that threw Brian's original exception

Here’s where debugging gets really interesting. Add one more line to the debugger—the statement that actually threw the exception: `fileNames[random.Next(fileNames.Length)]`. As soon as you type it in, the Watch window evaluates it... and that throws the exception. It tells you that it found the exception by displaying an exclamation point, and displays the text of the exception in the Value column.

This exclamation point is the Watch window’s way of telling you it found an exception.

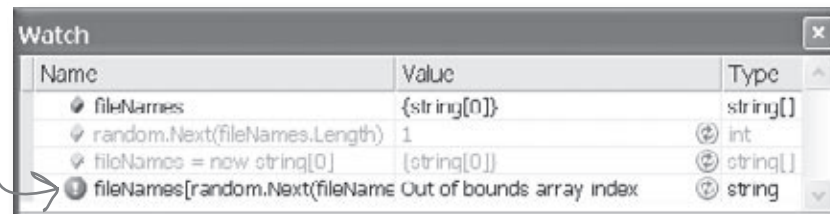

When you get an exception, you can go back and reproduce it in the debugger. That’s another way that more descriptive exception messages can help you fix your code.

there are no Dumb Questions

Q: How come Brian's unhandled exception window looked different than the one in the IDE?

A: Because when you run a program inside the IDE, you're running it in the debugger, which **breaks the program** (as if you'd pressed the Break All button or inserted a breakpoint) as soon as it intercepts an exception, and displays it in a useful window. That lets you inspect the Exception object and your program's fields and variables so you can track down the problem.

When Brian ran his program, he wasn't running it from inside the IDE. He'd published his program and installed it, just like you did back in Chapter 1 with the Contact List program. You can run your program outside the IDE any time without publishing it—just build your program, which causes Visual Studio to create an executable file. Just look inside your project's folder for the `bin/` folder—one of its subdirectories should have the `exe` file for your application. If you run that, any exceptions that it throws will be unhandled and show the same window that Brian saw.

Q: So that's it? When an exception happens outside the IDE, my program just stops and there's nothing I can do about it?

A: Well, your program does stop when there's an **unhandled** exception. But that doesn't mean that all of your exceptions have to be unhandled! We'll talk a lot more about how you can handle exceptions in your code. There's no reason your users ever have to see an unhandled exception.

Q: How do I know where to put a breakpoint?

A: That's a really good question, and there's no one right answer. When your code throws an exception, it's always a good idea to start with the statement that threw it. But usually, the problem actually happened earlier in the program, and the exception is just fallout from it. For example, the statement that throws a divide by zero error could be dividing values that were generated 10 statements earlier but just haven't been used yet. So there's no one good answer to where you should put a breakpoint, because every situation is different. But as long as you've got a good idea how your code works, you should be able to figure out a good starting point.

Q: Can I run any method in the Watch window?

A: Yes. Any statement that's valid in your program will work inside the Watch window, even things that make absolutely no sense to run inside a Watch window. Here's an example. Bring up a program, start it running, break it, and then add this to the Watch window: `System.Threading.Thread.Sleep(2000)`. (Remember, that method causes your program to delay for two seconds.) There's no reason you'd ever do that in real life, but it's interesting to see what happens: you'll get an hourglass for two seconds while the method evaluates. Then, since `Sleep()` has no return value, the Watch window will display the value, "Expression has been evaluated and has no value" to let you know that it didn't return anything. But it did evaluate it. Not only that, but it displays IntelliSense pop-ups to

help you type code into the window. That's useful because it'll tell you what methods are available to an object when your program is running.

Q: Wait, so isn't it possible for me to run something in the Watch window that'll change the way my program runs?

A: Yes! Not permanently, but it can definitely affect your program's output. But even better, just **hovering** over fields inside the debugger can cause your program to change its behavior, because hovering over a property **executes its get accessor**. If you have a property that's got a get accessor that executes a method, then hovering over that property will cause that method to execute. And if that method sets a value in your program, then that value will stay set if you run the program again. And that can cause some pretty unpredictable results inside the debugger. Programmers have a name for results that seem to be unpredictable and random: they're called **heisenbugs** (which is a joke that makes sense to physicists and cats in boxes).

When you run your program inside the IDE, an unhandled exception will cause it to break as if it had run into a breakpoint.

Uh-oh—the code’s still got problems...

Brian was happily using his Excuse Manager, when he remembered that he had a folder full of excuses that he made when he first built the program—but he forgot that he made that folder *before* he added serialization to the program. Let’s see what happens...

No, not again!



- 1 You can re-create Brian’s problem—just create your own text-based Excuse file using Notepad. The first line should be the description, the second should be the results, and the third should be the last used date (“10/4/2007 12:08:13 PM”).
- 2 Pop open the Excuse Manager and open up the excuse. It throws an exception! But this time, click on the Details button so we can take a closer look at what it says. Pay attention to the **call stack**—that’s what it’s called when a method is called by another method, which is called by another method, etc.

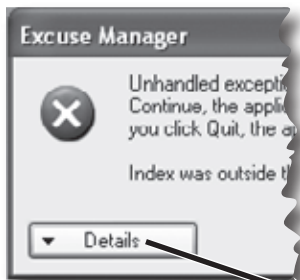

It looks like there was a problem with the `BinaryFormatter`—which makes sense, because it was trying to deserialize a text file.

You can learn a lot from the **call stack**, which tells you which methods were running. You can see that the `Excuse` class’s `OpenFile()` method was being called from its constructor (“`.ctor`”), which was called from the “Random Excuse” button’s click event handler.

The program threw a `SerializationException`. Can we figure out what line threw it from the exception details?

```
***** Exception Text *****
System.Runtime.Serialization.SerializationException: End of Stream encountered before parsing
was completed.

   at System.Runtime.Serialization.Formatters.Binary.__BinaryParser.Run()
   at System.Runtime.Serialization.Formatters.Binary.ObjectReader.Deserialize(HeaderHa
ndler handler, __BinaryParser serParser, Boolean fCheck, Boolean isCrossAppDomain,
IMethodCallMessage methodCallMessage)
   at System.Runtime.Serialization.Formatters.Binary.BinaryFormatter.Deserialize(Stream
serializationStream, HeaderHandler handler, Boolean fCheck, Boolean isCrossAppDomain,
IMethodCallMessage methodCallMessage)
   at System.Runtime.Serialization.Formatters.Binary.BinaryFormatter.Deserialize(Stream
serializationStream)
   at Chapter10.Excuse.OpenFile(String ExcusePath) in C:\Documents and Settings\Administrator\
My Documents\Visual Studio 2005\Projects\Chapter10\Chapter10\Excuse.cs:line 40
   at Chapter10.Excuse..ctor(Random random, String Folder) in C:\Documents and Settings\
Administrator\My Documents\Visual Studio 2005\Projects\Chapter10\Chapter10\Excuse.cs:line 30
   at Chapter10.Form1.RandomExcuseButton_Click(Object sender, EventArgs e) in C:\
Documents and Settings\Administrator\My Documents\Visual Studio 2005\Projects\Chapter10\
Chapter10\Form1.cs:line 146
```

- 3 So the Details button in the unhandled exception window tells you a lot about what caused this problem. *Can you think of anything you can do about it?*

Wait a second. Of course the program's gonna crash—I gave it a bad file. Users screw up all the time. You can't expect me to do anything about that, right?



Actually, there is something you can do about it. Yes, it's true that users screw up all the time. That's a fact of life. But that doesn't mean you can't do anything about it. There's a name for programs that deal with bad data, malformed input, and other unexpected situations gracefully: they're called **robust**. And C# gives you some really powerful exception handling tools to help you make your programs more robust. Because while you *can't* control what your users do, you *can* make sure that your program doesn't crash when they do it.

ro-bust, adj.
sturdy in construction; able to withstand or overcome adverse conditions. *After the Tacoma Narrows Bridge disaster, the civil engineering team looked for a more **robust** design for the bridge that would replace it.*



Watch it!

BinaryFormatter will throw an exception if there's anything at all wrong with a serialized file.

It's easy to get the Excuse Manager to throw a `SerializationException`—just feed it any file that's not a serialized `Excuse` object. When you try to deserialize an object from a file, `BinaryFormatter` expects the file to contain a serialized object that matches the class that it's trying to read. If the file contains anything else, anything at all, then the `Deserialize()` method will throw a `SerializationException`.

Handle exceptions with try and catch

In C#, you can basically say, “**Try** this code, and if an exception occurs, **catch** it with this *other* bit of code.” The part of code you’re trying is the **try block**, and the part where you deal with exceptions is called the **catch block**. In the catch block, you can do things like print a friendly error message, instead of letting your program come to a screeching halt:

```
private void RandomExcuseButton_Click(object sender,
EventArgs e) {
    // ... code you added a few pages ago goes here ...
```

```
try {
```

This is the try block. You start exception handling with try.

```
    if (CheckChanged() == true) {
```

```
        CurrentExcuse = new Excuse(random, Folder);
```

```
        UpdateForm(false);
```

Put the code that might throw an exception inside the try block. If no exception happens, it'll get run exactly as usual, and the statements in the catch block will be ignored. But if a statement in the try block throws an exception, the rest of the try block won't get executed.

```
    }
```

The catch keyword means that the block immediately following it contains an exception handler.

```
catch {
```

When an exception is thrown, the program immediately jumps to the catch statement and starts executing the catch block.

```
    MessageBox.Show(
```

```
        "Your excuse file was invalid.",
```

```
        "Unable to open a random excuse");
```

```
    }
```

This is the simplest kind of exception handling: stop the program, write out the exception message, and keep running.



If throwing an exception makes your code automatically jump to the catch block, what happens to the objects and data you were working with before the exception happened?

What happens when a method you want to call is risky?

Users are unpredictable. They feed all sorts of weird data into your program, and click on things in ways you never expected. And that's just fine, because you can handle unexpected input with good exception handling.

- 1 Let's say your user is using your code, and gives it some input that it didn't expect.

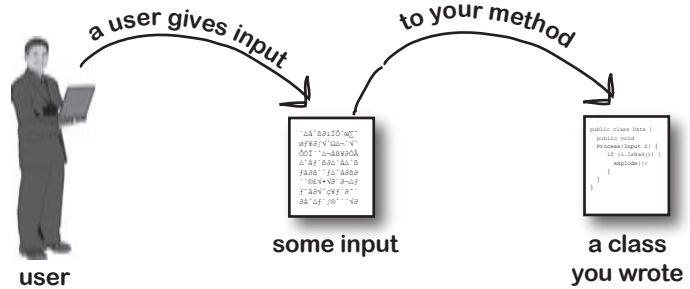

- 2 That method does something risky, something that might not work at runtime.

```

public class Data {
    public void
    Process(Input i) {
        if (!i.IsBad()) {
            explode();
        }
    }
}
    
```

a class you wrote

"Runtime" just means "while your program is running". Some people refer to exceptions as "runtime errors".

- 3 You need to know that the method you're calling is risky.



- 4 You then write code that can handle the failure if it *does* happen. You need to be prepared, just in case.

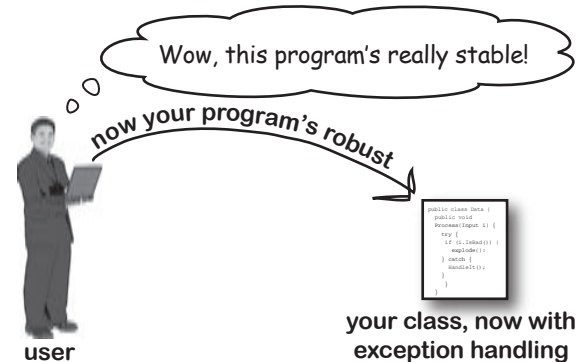

there are no Dumb Questions

Q: So when do I use try and catch?

A: Any time you're writing risky code, or code that could throw an exception. The trick is figuring out which code is risky, and which code is safer.

You've already seen that code that uses input provided by a user can be risky. Users give you incorrect files, words instead of numbers, names instead of dates, and they pretty much click everywhere you could possibly imagine. And a good program will take all that input and work in a calm, predictable way. It might not give the users a result they can use, but it will let them know that it found the problem and hopefully suggest a solution.

Q: How can a program suggest a solution to a problem it doesn't even know about in advance?

A: That's what the catch block is for. A catch block is only executed when code in the try block throws an exception. It's your chance to make sure the user knows that something went wrong, and to let the user know that it's a situation that might be corrected.

If the excuse manager simply crashes when there's bad input, that's not particularly useful. But if it tries to read the input and displays garbage in the form, that's also not

useful—fact, some people might say that it's worse. But if you have the program display an error message telling the user that it couldn't read the file, then the user has an idea of what went wrong, and information that he can use to fix the problem.

Q: Is the debugger only used to troubleshoot exceptions?

A: No. The debugger's actually a really useful tool that you can use to examine any code you've written. Sometimes it's useful to step through your code and check the value of certain fields and variables—like when you've got a really complex method, and you want to make sure it's working properly.

But as you may have guessed from the name "debugger," its most common use is to track down and remove bugs. Sometimes those bugs are exceptions that get thrown. But a lot of the time, you'll be using the debugger to try to find other kinds of problems, like code that gives a result that you don't expect.

Q: I'm not sure I totally got the Watch window. What's it for, again?

A: When you're debugging a program, you usually want to pay attention to how a few variables and fields change. That's where the Watch window comes in. If you

add watches for a few variables, the Watch window updates their values every time you step into, out of or over code. That lets you monitor exactly what happens to them after every statement, which can be really useful when you're trying to track down a problem.

The Watch window also lets you type in any statement you want, and it'll evaluate it. If the statement updates any of the fields and variables in your program, then it does that, too. That lets you change values while your program is running, which can be another really useful tool for reproducing exceptions and other bugs.

Any changes you make in the Watch window just affect the data in memory, and only last as long as the program is running. Restart your program, and values that you changed will be undone.

The catch block is only executed when code in the try block throws an exception. It gives you a chance to make sure your user has the information to fix the problem.

Use the debugger to follow the try/catch flow

An important part of exception handling is that when a statement in your try block throws an exception, the rest of the code in the block gets **short-circuited**. The program's execution immediately jumps to the first line in the catch block. **But don't take our word for it...**

Debug this

- 1 Make sure that you've incorporated all of the code from this chapter into the Random Excuse button in your Excuse Manager. Place a breakpoint on the first line in the Random Excuse button's Click event handler. Then run your program in the IDE. Click the Folder button and specify a folder with a single excuse file in it—and make sure it's a **not a valid excuse file** (any other sort of file will cause it to throw an exception). Press the Random Excuse button. The debugger should break the program at the breakpoint you placed. Press the "Step Over" button (or F10) six times to get to the statement that calls the Excuse constructor. Here's what your debugger screen should look like:

Place a breakpoint on the first line of the Random Excuse button event handler.

Step over the statements until your yellow "next statement" bar shows that the next statement to get executed will create the new Excuse object.

```
private void RandomExcuseButton_Click(object sender, EventArgs e) {
    string[] fileNames = Directory.GetFiles(Folder, "*.excuse");
    if (fileNames.Length == 0) {
        MessageBox.Show("Please specify a folder with excuse files in it",
            "No excuse files found");
    } else {
        try {
            if (CheckChanged()) {
                CurrentExcuse = new Excuse(random, Folder);
                UpdateForm(false);
            }
        } catch {
            MessageBox.Show(
                "Your excuse file was invalid.",
                "Unable to open a random excuse");
        }
    }
}
```

Make sure you use the Step Over (F10) command in the debugger so it doesn't step into the CheckChanged() method.

- 2 Use Step Into (F11) to step into the new statement. The debugger will jump to the Excuse constructor, and position its yellow "next statement" bar over the declaration line in the code. Keep hitting Step Into (F11) to step into the OpenFile() method. Watch what happens when you hit the Deserialize() line.

As soon as you step into the new statement that creates the Excuse object, the debugger jumps to the constructor code.

```
public Excuse(Random random, string folder)
{
    string[] fileNames = Directory.GetFiles(folder, "*.excuse");
    OpenFile(fileNames[random.Next(fileNames.Length)]);
}
```

- 3 As soon as the debugger executes the `Deserialize()` statement, the exception is thrown and the program jumps straight to the first statement in the catch block. It **short-circuited** right past the call to `UpdateForm()` and **jumped straight to the catch block**.

The debugger will highlight the catch statement with its yellow “next statement” block, but it shows the rest of the block in grey to show you that it’s about to execute the whole thing.

```
private void RandomExcuseButton_Click(object sender, EventArgs e) {
    string[] fileNames = Directory.GetFiles(Folder, "*.excuse");
    if (fileNames.Length == 0) {
        MessageBox.Show("Please specify a folder with excuse files in it",
            "No excuse files found");
    } else {
        try {
            if (CheckBox1.Checked) {
                CurrentExcuse = new Excuse(random, Folder);
                UpdateForm(false);
            }
        } catch {
            MessageBox.Show(
                "Your excuse file was invalid.",
                "Unable to open a random excuse");
        }
    }
}
```

- 4 Start the program again by pressing the Continue button (or F5). It’ll begin running the program again, starting with whatever’s highlighted by the yellow “next statement” block—in this case, the catch block.



Here’s a career tip: a lot of C# programming job interviews include a question about how you deal with exceptions in a constructor.



Be careful with exceptions in a constructor!

You’ve noticed by now that a constructor doesn’t have a return value, not even `void`. That’s because a constructor doesn’t actually return anything. Its only purpose is to initialize an object—which is a problem for exception handling inside the constructor. When an exception is thrown inside the constructor, then the statement that tried to instantiate the class **won’t end up with an instance of the object**. That’s why you had to move the try/catch block to the button’s event handler. That way, if there’s an exception in the constructor, the code won’t expect `CurrentExcuse` to contain a valid `Excuse` object.

If you have code that ALWAYS should run, use a finally block

When your program throws an exception, a couple of things can happen. If the exception *isn't* handled, your program will stop processing and crash. If the exception *is* handled, your code jumps to the catch block. But what about the rest of the code in your try block? What if you were closing a stream, or cleaning up important resources? That code needs to run, even if an exception occurs, or you're going to make a mess of your program's state. That's where the **finally** block comes in really handy. It comes after the try and catch blocks. The **finally block always runs**, whether or not an exception was thrown. Here's how you'd use it to finish the event handling in the Random Excuse button:

```
private void RandomExcuseButton_Click(object sender, EventArgs e) {
    string[] fileNames = Directory.GetFiles(Folder, "*.excuse");
    if (fileNames.Length == 0) {
        MessageBox.Show("Please specify a folder with excuse files in it",
            "No excuse files found");
    } else {
        try {
            if (CheckChanged() == true) {
                CurrentExcuse = new Excuse(random, Folder);
            }
        }
        catch (Exception) {
            CurrentExcuse = new Excuse();
            CurrentExcuse.Description = "";
            CurrentExcuse.Results = "";
            CurrentExcuse.LastUsed = DateTime.Now;
            MessageBox.Show(
                "Your excuse file was invalid.",
                "Unable to open a random excuse");
        }
        finally {
            UpdateForm(false);
        }
    }
}
```

If the Excuse constructor throws an exception, we have no way of knowing what's in CurrentExcuse. But you do know that no instance of Excuse was created. So the catch block creates a new Excuse object and clears out all its fields.

The finally block makes sure that UpdateForm() gets run whether or not an exception was thrown. So if the Excuse constructor successfully read an excuse, it'll call UpdateForm(), but it'll also call it if the constructor threw an exception and cleared out the excuse.

Did you notice how catch was followed by (Exception)? When you have a catch statement, you can follow it with a specific kind of exception telling it what to catch. If you specify **(Exception)** or leave it out, it catches all exceptions. But if you only wanted to catch a `SerializationException`, you could specify that inside the parentheses instead. Or you could use an **IOException**, which will catch **any file input or output problem**.

Now debug this

- 1 Update the Random Excuse button's event handler with the code on the facing page. Then place a breakpoint on the first line in the method and debug the program.
- 2 Run the program normally, and make sure that the Random Excuse button works when you set the program's folder to one with a bunch of normal excuse files in it. The debugger should break at the breakpoint you set:

When the "next statement" bar and the breakpoint are on the same line, the IDE shows you the yellow arrow placed over the big red dot in the margin.

```
private void RandomExcuseButton_Click(object sender, EventArgs e) {
    string[] fileNames = Directory.GetFiles(Folder, "*.excuse");
    if (fileNames.Length == 0) {
        MessageBox.Show("Please specify a folder with excuse files in it",
            "No excuse files found");
    } else {
        try
        {
            if (CheckBox1.Checked) {
                CurrentExcuse = new Excuse(random, Folder);
            }
        }
        catch (Exception) {
            CurrentExcuse = new Excuse();
            CurrentExcuse.Description = "";
            CurrentExcuse.Results = "";
            CurrentExcuse.LastUsed = DateTime.Now;
            MessageBox.Show(
                "Your excuse file was invalid.",
                "Unable to open a random excuse");
        }
        finally {
            UpdateForm(false);
        }
    }
}
```

- 3 Step through the rest of the Random Excuse button's event handler and make sure it runs the way you expect it to. It should finish the `try` block, skip over the `catch` block (because no exceptions were thrown), and then execute the `finally` block.
- 4 Now set the program's folder so that it's pointed to the folder with one malformed excuse file in it and click the Random excuse button. It should start executing the `try` block, and then jump to the `catch` block when it throws the exception. After it finishes all of the statements in the `catch` block, it'll execute the `finally` block.

there are no Dumb Questions

Q: Back up a second. So every time my program runs into an exception, it's going to stop whatever it's doing unless I specifically write code to catch it. How is that a good thing?

A: One of the best things about exceptions is that they make it really obvious when you run into problems. Imagine how easy it could be in a complex application for you to lose track of all of the objects your program was working with. Exceptions call attention to your problems and help you root out their causes so that you always know that your program is doing what it's supposed to do.

Any time an exception occurs in your program, something you expected to happen didn't. Maybe an object reference wasn't pointing where you thought it was, or it was possible for a user to supply a value you hadn't considered, or a file you thought you'd be working with suddenly isn't available. If something like that happened and you didn't know it, it's likely that the output of your program would be wrong, and the behavior from that point on would be pretty different than you expected when you wrote the program.

Now imagine that you had no idea the error had occurred and your users started calling you up with incorrect data and telling you that your program was unstable. That's why it's a *good* thing that exceptions disrupt everything your program is doing. They force you to deal with the problem while it's easy to find and fix.

Q: Okay, so now what's a handled exception and what's an unhandled exception?

A: Whenever your program throws an exception, the runtime environment will

search through your code looking for a catch block that matches it. If you've written one, the catch block will execute and do whatever you specified for that particular exception. Since you wrote a catch block to deal with that error up front, that exception is considered handled. If the runtime can't find a catch block to match the exception, it stops everything your program is doing and raises an error. Then, you'd call the exception unhandled.

Q: What was that bit about specifying a particular kind of exception to catch? Why would I ever want to do that?

A: You *usually* don't want to catch every kind of exception. In fact, you should do your best to avoid catching `Exception`, and instead catch specific exceptions. For example, let's say you wanted your `Excuse` class to prevent a `FileNotFoundException` from getting back to the form—say, if you wanted to make it so that if you tried to open a file that wasn't found, it would automatically create a `excuse` file with that filename and give it some default values. Then you could add a `try` block followed by `catch (FileNotFoundException)`. Then if a file isn't found, the class can handle it—but an `IOException` or `SerializationException` would not get caught, and the exception handler you added to the form would catch it. But if you do that, you have to make sure that there's *some* method in the call stack that does have a catch-all exception handler, otherwise the exception would be unhandled. And that would cause the users to see the ugly "unhandled exception" crash.

Q: What happens when you have a catch that doesn't specify a particular exception?

A: A catch block like that will catch any kind of exception the try block can throw.

Q: If a catch block with no specified exception will catch anything, why would I ever want to specify?

A: Good question. Because certain exceptions might require different actions to keep your program moving. An exception that happens when you divide by zero might have a catch block where you go back and set some number values to save some of the data you've been working with. A null reference exception might require that you create new instances of an object if you're going to recover.

Q: Does all error handling happen in a try/catch/finally sequence?

A: No. You can mix it up a bit. You could have **multiple catch blocks** if you wanted to deal with lots of different kinds of errors. You could also have no catch block at all. It's legal to have a try/finally block. That wouldn't handle any exceptions, but it would make sure that the code in the finally block ran even if you got stopped half way through the try block. But we'll talk a lot more about that in a minute...

An unhandled exception means your program will run unpredictably. That's why the program stops whenever it runs into one.

Pool Puzzle



Your **job** is to take code snippets from the pool and place them into the blank lines in the program. You can use the same snippet more than once, and you won't need to use all the snippets. Your **goal** is to make the program produce the output.

Output:  **G'day Mate!**

```
using System.IO;
public static void Main() {
    Kangaroo Joey = new Kangaroo();
    int Koala = Joey.Wombat(
        Joey.Wombat(Joey.Wombat(1)));
    try {
        Console.WriteLine((15 / Koala)
            + " eggs per pound");
    }
    catch (_____ ) {
        Console.WriteLine("G'Day Mate!");
    }
}
```

```
public class Kangaroo {
    _____ fs;
    int Croc;
    int Dingo = 0;

    public int Wombat(int Wallaby) {
        _____ __;
        try {
            if (_____ > 0) {
                __ = _____.OpenWrite("wobbiegong");
                Croc = 0;
            } else if (_____ < 0) {
                Croc = 3;
            } else {
                __ = _____.OpenRead("wobbiegong");
                Croc = 1;
            }
        }
        catch (IOException) {
            Croc = -3;
        }
        catch {
            Croc = 4;
        }
        finally {
            if (_____ > 2) {
                Croc ____ Dingo;
            }
        }
        _____ _____;
    }
}
```

Note: each snippet from the pool can be used more than once!

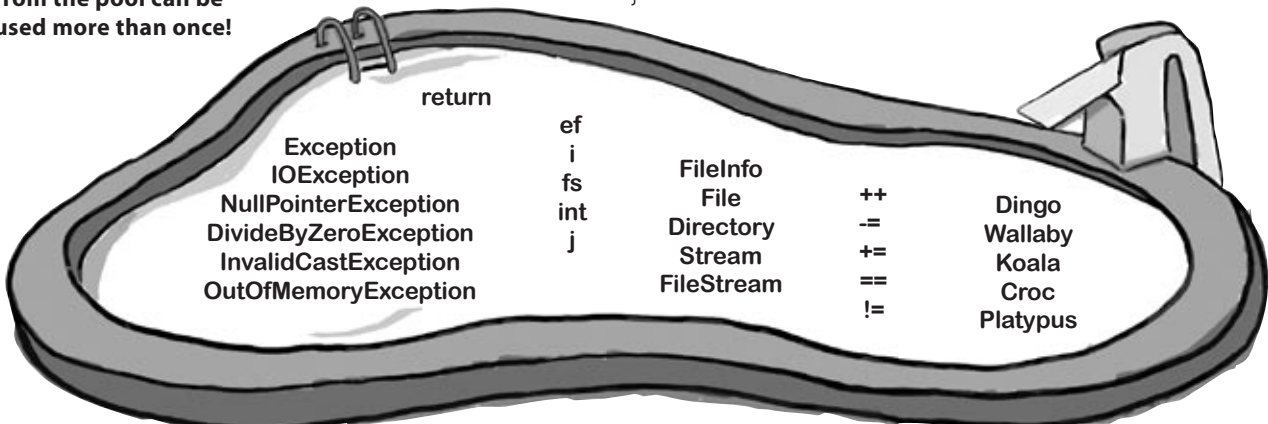

Pool Puzzle Solution



Joey.Wombat() is called three times, and the third time it returns zero. That causes the WriteLine() to throw a DivideByZeroException.

```
public static void Main() {
    Kangaroo Joey = new Kangaroo();
    int Koala = Joey.Wombat(Joey.Wombat(Joey.Wombat(1)));
    try {
        Console.WriteLine((15 / Koala) + " eggs per pound");
    }
    catch (DivideByZeroException) {
        Console.WriteLine("G'Day Mate!");
    }
}
```

The clue that this is a FileStream is that it has an OpenRead() method and throws an IOException.

```
public class Kangaroo {
    FileStream fs;
    int Croc;
    int Dingo = 0;

    public int Wombat(int Wallaby) {
        Dingo ++;
        try {
            if (Wallaby > 0) {
                fs = File.OpenWrite("wobbiegong");
                Croc = 0;
            } else if (Wallaby < 0) {
                Croc = 3;
            } else {
                fs = File.OpenRead("wobbiegong");
                Croc = 1;
            }
        }
        catch (IOException) {
            Croc = -3;
        }
        catch {
            Croc = 4;
        }
        finally {
            if (Dingo > 2) {
                Croc -= Dingo;
            }
        }
        return Croc;
    }
}
```

This catch block only catches exceptions where the code divides by zero.

This code opens a file called "wobbiegong" and keeps it open the first time it's called. Later on, it opens the file again. But it never closed the file, which causes it to throw an IOException.

You already know that you always have to close files when you're done with them. If you don't, the file will be locked open, and if you try to open it again it'll throw an IOException.

Use the Exception object to get information about the problem

We've been saying all along that .NET generates an `Exception` object when an exception is thrown. When you write your `catch` block, you have access to that object. Here's how it works:

- 1 An object is humming along, doing its thing, when it encounters something unexpected and throws an exception.

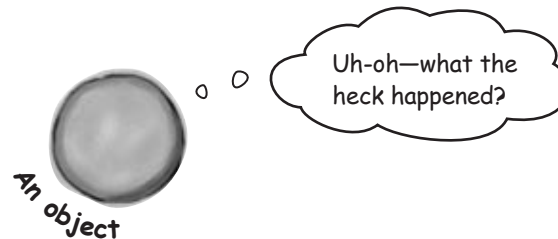

- 2 Luckily, its `try/catch` block caught the exception. Inside the `catch` block, it gave the `Exception` a name: `ex`.

```
try {
    DoSomethingRisky();
}
catch (Exception ex) {
    string message = ex.Message;
    MessageBox.Show(message, "An error occurred");
}
```

When you specify a specific type of exception in the `catch` block, if you provide a variable name then your code can use it to access the `Exception` object.

- 3 The exception object stays around until the `catch` block is done. Then the `ex` reference disappears, and it's garbage collected.

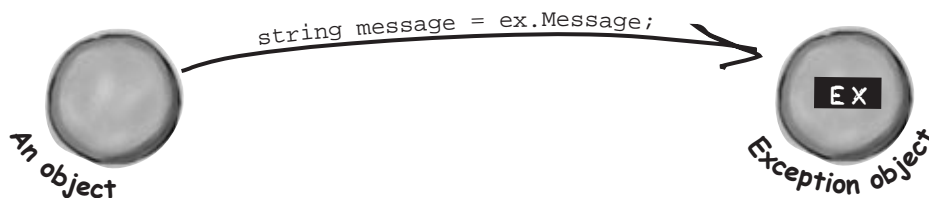

Use more than one catch block to handle multiple types of exceptions

You know that you can catch a specific type of exception . . . but what if you write code where more than one problem can occur? In these cases, you may want to write code that handles each different type of exception. That's where using more than one catch block comes in. Here's an example from code from the beehive nectar processing plant. You can see how it catches several kinds of exceptions. In some cases it uses properties in the Exception object. It's pretty common to use the **Message** property, which usually contains a description of the exception that was thrown.

You can also call the exception's `ToString()` method to get a lot of the pertinent data into your `MessageBox`.



```
public void ProcessNectar(NectarVat vat, Bee worker, HiveLog log) {
    try {
        NectarUnit[] units = worker.EmptyVat(vat);
        for (int count = 0; count < worker.UnitsExpected, count++) {
            stream hiveLogFile = log.OpenLogFile();
            worker.AddLogEntry(hiveLogFile);
        }
        catch (IndexOutOfRangeException) {
            vat.Emptied = true;
        }
        catch (IOException ex) {
            worker.AlertQueen("Log file is corrupted: " + ex.Message);
        }
        catch (Exception ex) {
            worker.AlertQueen("An unspecified error happened: "
                + "Message: " + ex.Message + "\r\n"
                + "Stack trace: " + ex.StackTrace + "\r\n"
                + "Data: " + ex.Data + "\r\n");
        }
    finally {
        vat.Seal();
        worker.FinishedJob();
    }
}
```

If you won't use the `Exception` object, there's no need to declare it.

When you have several catch blocks, they're examined in order. In this code, first it checks to see if there was an index out of range. If not, then it'll check for a file I/O exception. The last catch block is a general catch-all exception that will get executed for any exception that wasn't already caught.

This catch block assigns the exception to the variable `ex`, which it can use to get information from the `Exception` object.

It's fine for two blocks to use the same name ("`ex`") for the `Exception`.

This statement uses three properties in the `Exception` object: `Message`, which has the message you'd normally see in the exception window in the IDE ("Attempted to divide by zero"); `StackTrace`, which gives you a summary of the call stack; and `Data`, which sometimes contains pertinent data that's associated with the exception.

One class throws an exception, another class catches the exception

← Of course, one method in a single class can throw and catch its own exceptions.

When you're building a class, you don't always know how it's going to be used. Sometimes other people will end up using your objects in a way that causes problems—and sometimes you do it yourself! That's where exceptions come in.

The whole point behind throwing an exception is to see what might go wrong, so you can put in place some sort of contingency plan. You don't usually see a method that throws an exception and then catches it. An exception is usually thrown in one method and then caught in a totally different one—usually in a different object.

Instead of this...

Without good exception handling, one exception can halt the entire program. Here's how it would work in a program that manages bee profiles for a queen bee.

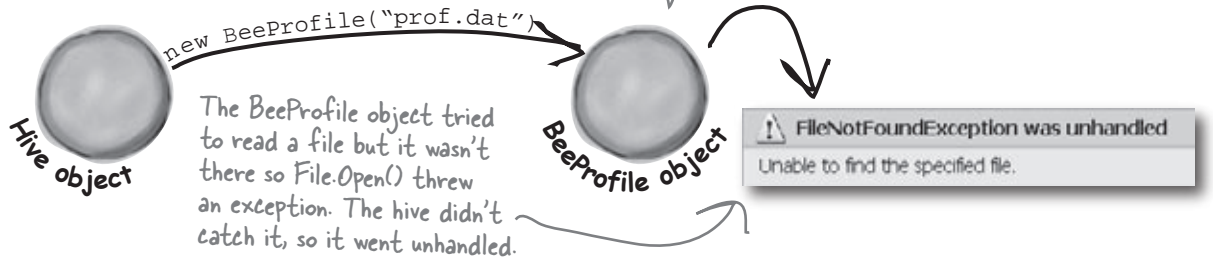

...we can do this.

The BeeProfile object can intercept the exception and add a log entry. Then it can turn around and throw the exception back to the hive, which catches it and recovers gracefully.

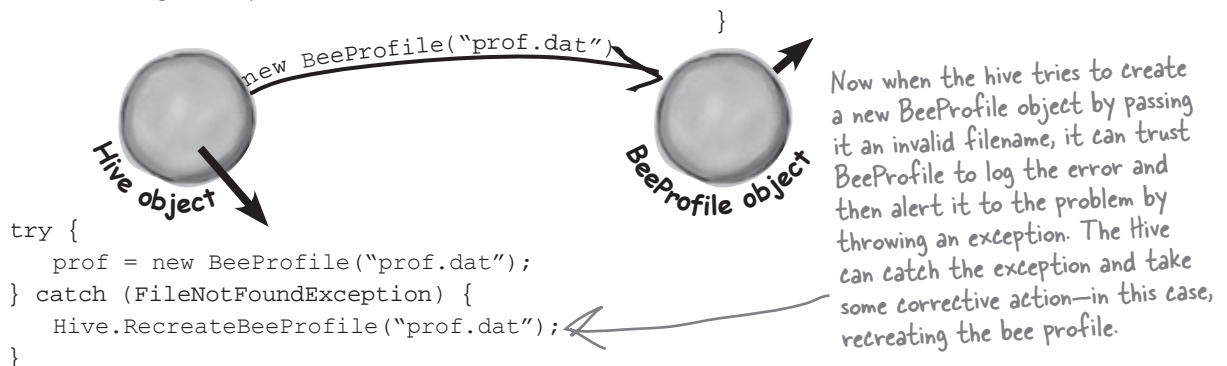

Bees need an OutOfHoney exception

Your classes can throw their own exceptions. For example, if you get a null parameter in a method that was expecting a value, it's pretty common to throw the same exception a .NET method would:

```
throw new ArgumentException();
```

Your methods can throw this exception if they get invalid or unexpected values in their parameters.

But sometimes you want your program to throw an exception because of a special condition that could happen when it runs. The bees we created in the hive, for example, consume honey at a different rate depending on their weight. If there's no honey left to consume, it makes sense to have the hive throw an exception. You can create a custom exception to deal with that specific error condition just by creating your own class that inherits from `Exception` and then throwing the exception whenever you encounter a specific error.

```
public class OutOfHoneyException : System.Exception {
    public OutOfHoneyException(string message) : base(message) { }
}

public class HoneyDeliverySystem {
    ...
    public void FeedHoneyToEggs() {
        if (honeyLevel == 0) {
            throw new OutOfHoneyException("The hive is out of honey.");
        } else {
            foreach (Egg egg in Eggs) {
                ...
            }
        }
    }
}

public partial class Form1 : Form {
    ...
    private void consumeHoney_Click(object sender, EventArgs e) {
        HoneyDeliverySystem delivery = new HoneyDeliverySystem();
        try {
            delivery.FeedHoneyToEggs();
        }
        catch (OutOfHoneyException ex) {
            MessageBox.Show(ex.Message, "Warning: Resetting Hive");
            Hive.Reset();
        }
    }
}
}
```

You need to create a class for your exception and make sure that it inherits from System.Exception. Notice how we're overloading the constructor so we can pass an exception message.

If there's honey in the hive, the exception will never get thrown and this code will run.

This throws a new instance of the exception object.

You can catch a custom exception by name just like any other exception, and do whatever you need to do to handle it.

In this case, if the hive is out of honey none of the bees can work, so the simulator can't continue. The only way to keep the program working once the hive runs out of honey is to reset it, and we can do that by putting the code to reset it in the catch block.

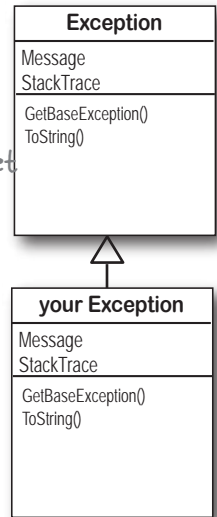



Exception Magnets

Arrange the magnets so the application writes the output to the console.

```
public static void Main() {
    Console.Write("when it ");
    ExTestDrive.Zero("yes");
    Console.Write(" it ");
    ExTestDrive.Zero("no");
    Console.WriteLine(".");
}
```

output:

when it thaws it throws.

```
class MyException : Exception { }
```

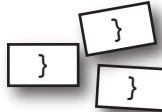

Every value type—including constants like "yes" or 37 or true—has built-in methods. So "yes".Equals(t) returns true if the variable t contains the string "yes".

```
if ("yes".Equals(t)) {
```

```
    Console.Write("a");
```

```
    Console.Write("o");
```

```
    Console.Write("t");
```

```
    Console.Write("w");
```

```
    Console.Write("s");
```

```
try {
```

```
    } catch (MyException) {
```

```
        throw new MyException();
```

```
    } finally {
```

```
        doRisky(test);
```

```
        Console.Write("r");
```

```
    }
```

```
public class ExTestDrive {
    public static void Zero(string test) {
```

```
        static void doRisky(String t) {
            Console.Write("h");
```



Exception Magnets Solution

Arrange the magnets so the application writes the output to the console.

```

public static void Main() {
    Console.WriteLine("when it ");
    ExTestDrive.Zero("yes");
    Console.WriteLine(" it ");
    ExTestDrive.Zero("no");
    Console.WriteLine(".");
}

```

output:
when it thaws it throws.

```

class MyException : Exception { }

```

This line defines a custom exception called `MyException`, which gets caught in a catch block in the code.

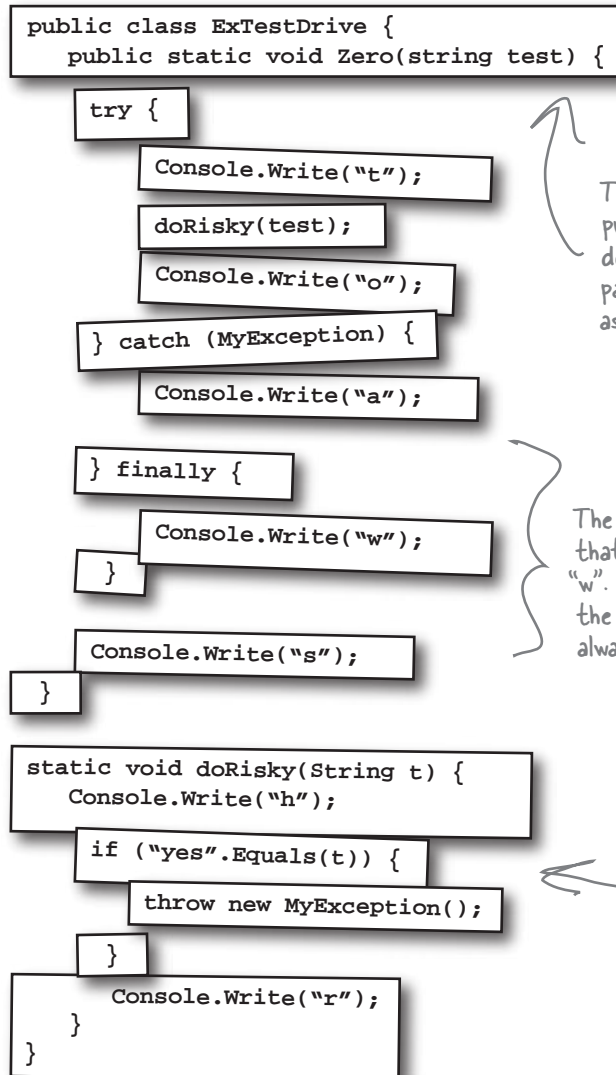

The `Zero()` method either prints "thaws" or "throws", depending on whether it was passed "yes" or something else as its test parameter.

The `finally` block makes sure that the method always prints "w". And the "s" is printed outside the exception handler, so it always prints, too.

This line only gets executed if `doRisky()` doesn't throw the exception.

The `doRisky()` method only throws an exception if it's passed the string "yes".

BULLET POINTS

- Any statement can throw an exception if something fails at runtime.
- Use a `try/catch` block to handle exceptions. Unhandled exceptions will cause your program to stop execution and pop up an error window.
- Any exception in the block of code after the `try` statement will cause the program's execution to immediately jump to the first statement in the block of code after `catch`.
- The `Exception` object gives you information about the exception that was caught. If you specify an `Exception` variable in your `catch` statement, that variable will contain information about any exception thrown in the `try` block:

```
try {
    // statements that might
    // throw exceptions
} catch (IOException ex) {
    // if an exception is thrown,
    // ex has information about it
}
```
- There are many different kinds of exception that you can catch. Each has its own object that inherits from `Exception`. Try to avoid just catching `Exception`—catch specific exceptions.
- Each `try` can have more than one `catch`:

```
try { ... }
catch (NullReferenceException ex) {
    // these statements will run if a
    // NullReferenceException is thrown
}
catch (OverflowException ex) { ... }
catch (Exception ex) {
    // Any exception that hasn't been
    // caught will jump to this block
}
```
- Your code can throw an exception using `throw`:

```
throw;

throw new Exception("Exception message");
```
- You can create a custom exception by inheriting from the `Exception` base class.

```
class CustomException : Exception;
```
- Most of the time, you only need to throw exceptions that are built into .NET, like `ArgumentException`. The reason you use different kinds of exceptions is so that you can **give more information to your users**. Popping up a window with the text "An unknown error has occurred" is not nearly as useful as an error message that says "The excuse folder is empty. Please select a different folder if you want to read excuses."

An easy way to avoid a lot of problems: `using` gives you `try` and `finally` for free

Remember, when you declare a reference in a "using" statement, its `Dispose()` method is automatically called at the end of the block.

You already know that `using` is an easy way to make sure that your files always get closed. But what you didn't know that it's really **just a C# shortcut** for `try` and `finally`!

```
using (YourClass c
    = new YourClass() ) {

    // code

}
```

is the same as this

```
YourClass c = new YourClass();

try {
    // code
} finally {
    c.Dispose();
}
```

When you use a `using` statement, you're taking advantage of `finally` to make sure its `Dispose()` method is always called.

Exception avoidance: implement IDisposable to do your own clean up

Streams are great, because they already have code written to close themselves when the object is disposed of. But what if you have your own custom object, and it always needs to do something when it's disposed of? Wouldn't it be great if you could write your own code that got run if your object was used in a using statement?

C# lets you do just that with the IDisposable interface. Implement IDisposable, and write your clean up code in the Dispose() method, like this:

```
class Nectar : IDisposable {
    private double amount;
    private BeeHive hive;
    private Stream hiveLog;
    public Nectar(double amount, BeeHive hive, Stream hiveLog) {
        this.amount = amount;
        this.hive = hive;
        this.hiveLog = hiveLog;
    }
    public void Dispose() {
        Hive.Add(amount);
        Hive.WriteHiveLogEntry(hiveLog,
            amount + "mg of nectar was added");
    }
}
```

← IDisposable is a really effective way to avoid common exceptions and problems. Make sure you use using statements any time you're working with any class that implements it.

← You can only use a class in a "using" statement if it implements IDisposable; otherwise, your program won't compile.

← Your object must implement IDisposable if you want to use your object within a using statement.

↳ The IDisposable interface only has one member: the Dispose() method. Whatever you put in this method will get executed at the end of the using statement.

← This particular code always logs the amount of nectar added. It's important, and must happen, so we put it in the Dispose() method.

↳ You'll see nested using statements like this when you need to declare two IDisposable references in the same block of code.

We can use multiple using statements now. First, let's use a built-in object Stream, which implements IDisposable. Then, we'll work with our updated Nectar object, which also implements IDisposable:

```
using (Stream Log = new File.Write("log.txt"))
using (Nectar nect = new Nectar(16.3, hive, Log)) {
    Bee.FlyTo(flower);
    Bee.Harvest(nect);
    Bee.FlyTo(hive);
}
```

↳ The Nectar object uses the Log stream, which will close automatically at the end of the outer using statement.

↳ Then the Bee object uses the nect object, which will log automatically at the end of the inner using statement.

there are no Dumb Questions

Q: Can I only use objects that implement `IDisposable` with a `using` statement?

A: Yes. `IDisposable` is tailor-made to work with `using` statements, and adding a `using` statement is just like creating a new instance of a class, except that it always calls its `Dispose()` method.

Q: Can you put any statement inside a `using` block?

A: Definitely. The whole idea with `using` is that it helps you make sure that every object you create with it is disposed. But what you do with those objects is entirely up to you. In fact, you can create an object with a `using` statement and never even use it inside the block. But that would be pretty useless, so we don't recommend doing that.

Q: Can you call `Dispose()` outside of a `using` statement?

A: Yes. You don't ever actually *need* to use a `using` statement. You can call `Dispose()` yourself when you're done with the object. Or you can do whatever cleanup is necessary—like calling a stream's `Close()` method manually. But if you use a `using` statement, it'll make your code easier to understand and prevent problems that happen if you don't dispose your objects.

Q: You mentioned a “try/finally” block. Does that mean it's okay to have a try and finally without a catch?

A: Yes! You can definitely have a try block without a catch, and just a finally. It looks like this:

```
try {
    DoSomethingRisky();
    SomethingElseRisky();
}
finally {
    AlwaysExecuteThis();
}
```

If `DoSomethingRisky()` throws an exception, then the `finally` block will immediately run.

Q: Does `Dispose()` only work with files and streams?

A: No, there are a lot of classes that implement `IDisposable`, and when you're using one you should always use a `using` statement. (You'll see some of them in the next few chapters.) And if you write a class that has to be disposed in a certain way, then you can implement `IDisposable`, too.

If try/catch is so great, why doesn't the IDE just put it around everything? Then we wouldn't have to write all these try/catch blocks on our own, right?



You want to know what type of exception is thrown, so you can handle that exception. There's more to exception handling than just printing out a generic error message. For instance, in the excuse finder, if we know we've got a `FileNotFoundException`, we might print an error that suggested where the right files should be located. If we have an exception related to databases, we might send an email to the database administrator. All that depends on you catching *specific* exception types.

This is why there are so many classes that inherit from `Exception`, and why you may even want to write your own classes to inherit from `Exception`.

The worst catch block EVER: comments

A catch block will let your program keep running if you want. An exception gets thrown, you catch the exception, and instead of shutting down and giving an error message, you keep going. But sometimes, that's not such a good thing.

Take a look at this `Calculator` class, which seems to be acting funny all the time. What's going on?

```
public class Calculator {  
    ...  
    public void Divide(float dividend, float divisor) {  
        try {  
            this.quotient = dividend / divisor;  
        } catch {  
            // Note from Jim: we need to figure out a way to prevent  
            // people from entering in zero in a division problem.  
        }  
    }  
}
```

Here's the problem. If divisor is zero, this will create a `DivideByZeroException`.

But there's a catch block. So why are we still getting errors?

The programmer thought that he could bury his exceptions by using an empty catch block, but he just caused a headache for whoever had to track down problems with it later.

You should handle your exceptions, not bury them

Just because you can keep your program running doesn't mean you've *handled* your exceptions. In the code above, the calculator won't crash... at least, not in the `Divide()` method. But what if some other code calls that method, and tries to print the results? If the divisor was zero, then the method probably returned an incorrect (and unexpected) value.

Instead of just adding a comment, and burying the exception, you need to **handle the exception**. And if you're not able to handle the problem, **don't leave empty or commented catch blocks!** That just makes it harder for someone else to track down what's going on. It's better to let the program continue to throw exceptions, because then it's easy to figure out what's going wrong.

Temporary solutions are okay (temporarily)

Sometimes you find a problem, and know it's a problem, but aren't sure what to do about it. In these cases, you might want to log the problem, and note what's going on. That's not as good as handling the exception, but it's better than doing nothing.

Here's a temporary solution to the calculator:

```
public class Calculator {
...
    public void Divide(float dividend, float divisor) {
        try {
            this.quotient = dividend / divisor;
        } catch (Exception ex) {
            StreamWriter sw = new StreamWriter(@"C:\Logs\errors.txt");
            sw.WriteLine(ex.getMessage());
            sw.Close();
        }
    }
}
```

← This still needs to be fixed, but short-term, this makes it clear where the problem occurred.

I get it. It's sort of like using exception handling to place a marker in the problem area.



Handling exceptions doesn't always mean the same thing as **FIXING** exceptions.

It's never good to have your program bomb out. But it's way worse to have no idea why it's crashing or what it's doing to users' data. That's why you need to be sure that you're always dealing with the errors you can predict and logging the ones you can't.

A few simple ideas for exception handling



DESIGN YOUR CODE TO HANDLE FAILURES GRACEFULLY.



GIVE YOUR USERS USEFUL ERROR MESSAGES.



THROW BUILT-IN .NET EXCEPTIONS WHERE YOU CAN. ONLY THROW CUSTOM EXCEPTIONS IF YOU NEED TO GIVE CUSTOM INFORMATION.



THINK ABOUT CODE IN YOUR TRY BLOCK THAT COULD GET SHORT-CIRCUITED.



... and most of all ...

AVOID UNNECESSARY FILE SYSTEM ERRORS... ALWAYS USE
A USING BLOCK ANY TIME YOU USE A STREAM!

ALWAYS ALWAYS ALWAYS!



Exercise

Use what you know about `try/catch/finally` to improve the exception handling in Brian's excuse manager.

- 1 Add exception handling to the Open button's Click event handler. Just make a simple `try/catch` block that pops up a message box. Here's what it should pop up if you try to open up a file that's not a real excuse file:

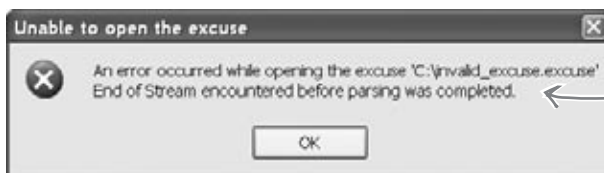

You'll get this exception message with a really small file, but a bigger one will give you a different error ("The input stream is not a valid binary format..."). Your message box should work either way.

- 3 You're not done yet. Open up the excuse manager, select a folder, enter data into the "Description" and "Last Results" boxes, **but don't enter a Last Used date**. Now select a folder and try saving the excuse. Did you get this `ArgumentOutOfRangeException` exception?

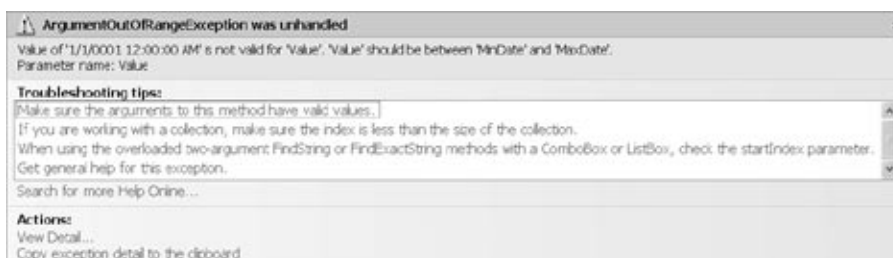

Use the debugger to track down the exception. This particular exception is totally avoidable—you can fix the program and make sure that the exception never happens? (*Hint: This has nothing to do with adding a `try/catch` block. You'll need to **figure out why** the "Last Used" date is causing a problem. Look carefully at the exception message for clues.*)

- 4 One last thing. Before the program threw the `ArgumentOutOfRangeException` exception, it saved out a file. Load that file in—you should get the same exception. And you'll get a different exception if you try to open a file that's not a valid excuse file. Add an exception handling block **nested inside the one you added in step 2** to make sure it doesn't fail when you try to load an invalid excuse file (which can happen in several situations). Here's what to do:
 1. Declare a boolean variable called `clearForm` above the `try/catch` block. You'll set this to true if there's an exception, and check it later to see if the form should be cleared.
 2. Add another `try/catch` block inside the one you just added to the Open button.
 3. Add a `finally` block to the outer `try/catch` to reset the form to its original empty state. Reset `LastUsed.Value` to `DateTime.Now` (which returns the current date) if the `clearForm` variable is set to true.



Exercise Solution

Use what you know about try/catch/finally to improve the exception handling to Brian's excuse manager.

```
private void open_Click(object sender, EventArgs e) {
    if (CheckChanged()) {
        openFileDialog1.InitialDirectory = selectedFolder;
        openFileDialog1.Filter =
            "Excuse files (*.excuse)|*.excuse|All files (*.*)|*.*";
        openFileDialog1.FileName = description.Text + ".excuse";
        DialogResult result = openFileDialog1.ShowDialog();
        if (result == DialogResult.OK) {
            bool clearForm = false;
            try {
                currentExcuse = new Excuse(openFileDialog1.FileName);
                try {
                    UpdateForm(false);
                }
                catch {
                    MessageBox.Show("The excuse file ""
                        + openFileDialog1.FileName + "" is invalid",
                        "Unable to open the excuse");
                    clearForm = true;
                }
            }
            catch (Exception ex) {
                MessageBox.Show("An error occurred while opening the excuse ""
                    + openFileDialog1.FileName + ""\n" + ex.Message,
                    "Unable to open the excuse", MessageBoxButtons.OK,
                    MessageBoxIcon.Error);
                clearForm = true;
            }
            finally {
                if (clearForm) {
                    description.Text = "";
                    results.Text = "";
                    lastUsed.Value = DateTime.Now;
                }
            }
        }
    }
}
```

Here's the try/catch block to create a pop up error, in case problems occur when the form calls the Excuse constructor to load an excuse.

Here's a nested try/catch. It handles exceptions that happen if the file gets loaded but has invalid data in it. That's not the same as problems arising from the Excuse constructor.

Here's the messagebox from the outer try/catch block. It prints the exception message.

Both catch blocks set clearForm to true so that this finally block knows that the form should be reset. It's okay to have code that interacts with your finally block, since you know finally blocks will always run.



Exceptioncross

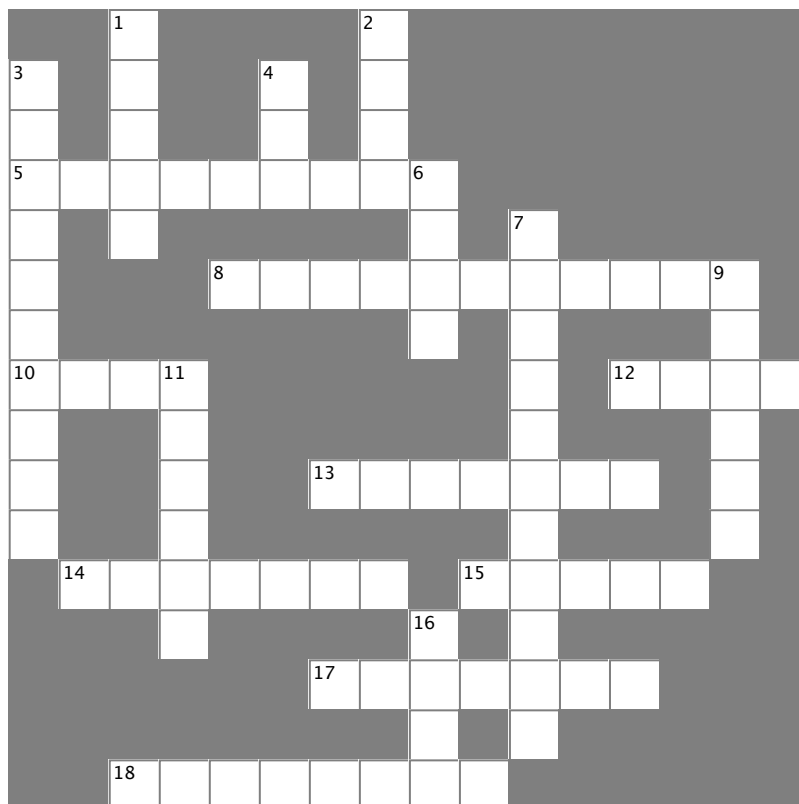

Across

5. The base class that DivideByZeroException and FormatException inherit from
8. An _____Exception happens when you try to cast a value to a variable that can't hold it
10. If the next statement is a method, "Step ____" tells the debugger to execute all the statements in the method and break immediately afterwards
12. If you ____ your exceptions, it can make them hard to track down
13. This method is always called at the end of a using block
14. The field in the Exception object that contains a string with a description
15. One try block can have multiple _____ blocks
17. The _____ block contains any statements that absolutely must be run after an exception is handled
18. An _____Exception means you tried to cram a number that was too big into a variable that couldn't hold it

Down

1. The window in the IDE that you can use to check your variables' values
2. You'll get an exception if you try to divide by this
3. Toggle this if you want the debugger to stop execution when it hits a specific line of code
4. "Step ____" tells the debugger to execute the rest of the statements in the current method and then break
6. What a reference contains if it doesn't point to anything
7. You can only declare a variable with a using statement if it implements this interface
9. When a statement has a problem, it _____ an exception
11. A program that handles errors well
16. If the next statement is a method, "Step ____" tells the debugger to execute the first statement in that method

Brian finally gets his vacation...

Now that Brian's got a handle on his exceptions, his job's going smoothly and he can take that well-deserved (and boss-approved!) vacation day.



...and things are looking up back home!

Your exception handling skills did more than just prevent problems. They ensured that Brian's boss has no idea anything went wrong in the first place!



Good ol' Brian. Never misses a day of work unless he's got a **real** problem.

Good exception handling is invisible to your users. The program never crashes, and if there are problems, they are handled gracefully, without confusing error messages.

11 events and delegates

What your code does when you're not looking

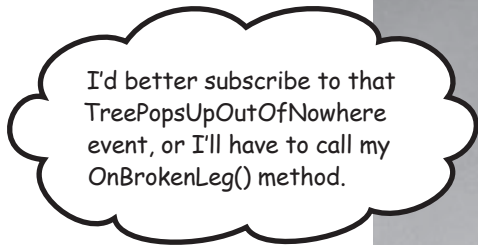

Your objects are starting to think for themselves.

You can't always control what your objects are doing. Sometimes things...happen. And when they do, you want your objects to be smart enough to **respond to anything** that pops up. And that's what events are all about. One object *publishes* an event, other objects *subscribe*, and everyone works together to keep things moving. Which is great, until you've got too many objects responding to the same event. And that's when **callbacks** will come in handy.

Ever wish your objects could think for themselves?

Suppose you're writing a baseball simulator. You're going to model a game, sell the software to the Yankees (they've got deep pockets, right?), and make a million bucks. You create your `Ball`, `Pitcher`, `Umpire`, and `Fan` objects, and a whole lot more. You even write code so that the `Pitcher` object can catch a ball.

That's a standard way of naming methods—we'll talk more about it later.

Now you just need to connect everything together. You add an `OnBallInPlay()` method to `Ball`, and now you want your `Pitcher` object to respond with its event handler method. Once the methods are written, you just need to tie the separate methods together:

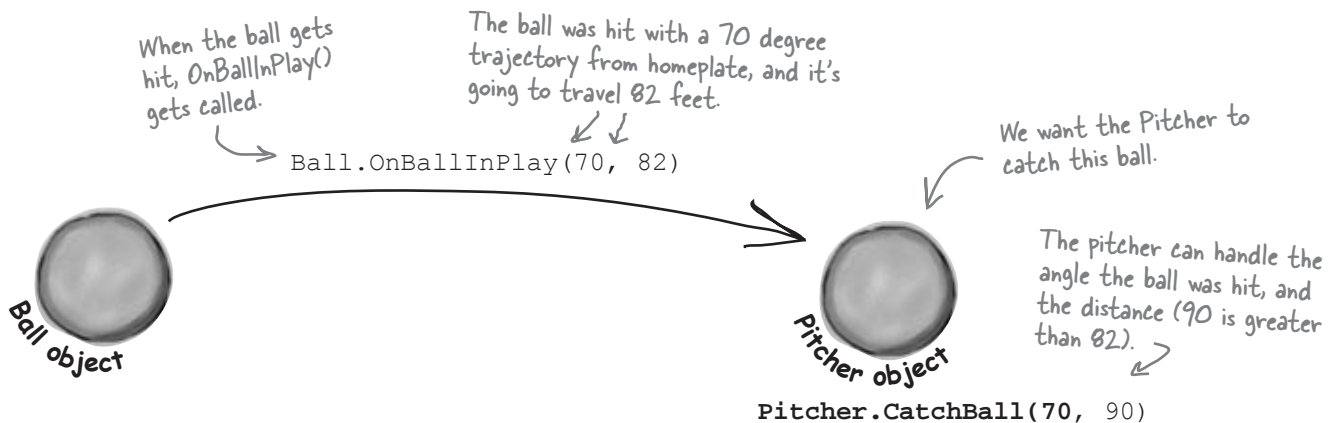

But how does an object KNOW to respond?

Here's the problem. You really want your `Ball` object to only worry about getting hit, and your `Pitcher` to object only worry about catching balls that come its way. In other words, you really don't want the `Ball` telling the `Pitcher`, "I'm coming to you."

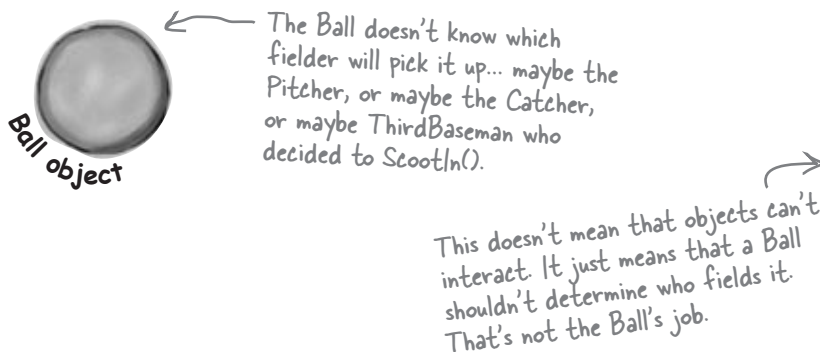

You want an object to worry about itself, not other objects.
You're separating the concerns of each object.

When an EVENT occurs... objects listen

What you need to do when the ball is hit is use an **event**. An event is simply **something that's happened** in your program. Then, other objects can respond to that event—like our `Pitcher` object.

Even better, more than one object can listen for events. So the `Pitcher` could listen for a ball-being-hit event, as well as a `Catcher`, `ThirdBaseman`, an `Umpire`, even a `Fan`. And each object can respond to the event differently.

So what we want is a `Ball` object that can **raise an event**. Then, we want to have other objects to **subscribe to that particular type of event...** that just means listen to it, and get notified when that event occurs.

event, noun.
a **thing** that happens, especially something of importance. *The solar eclipse was an amazing event to behold.*

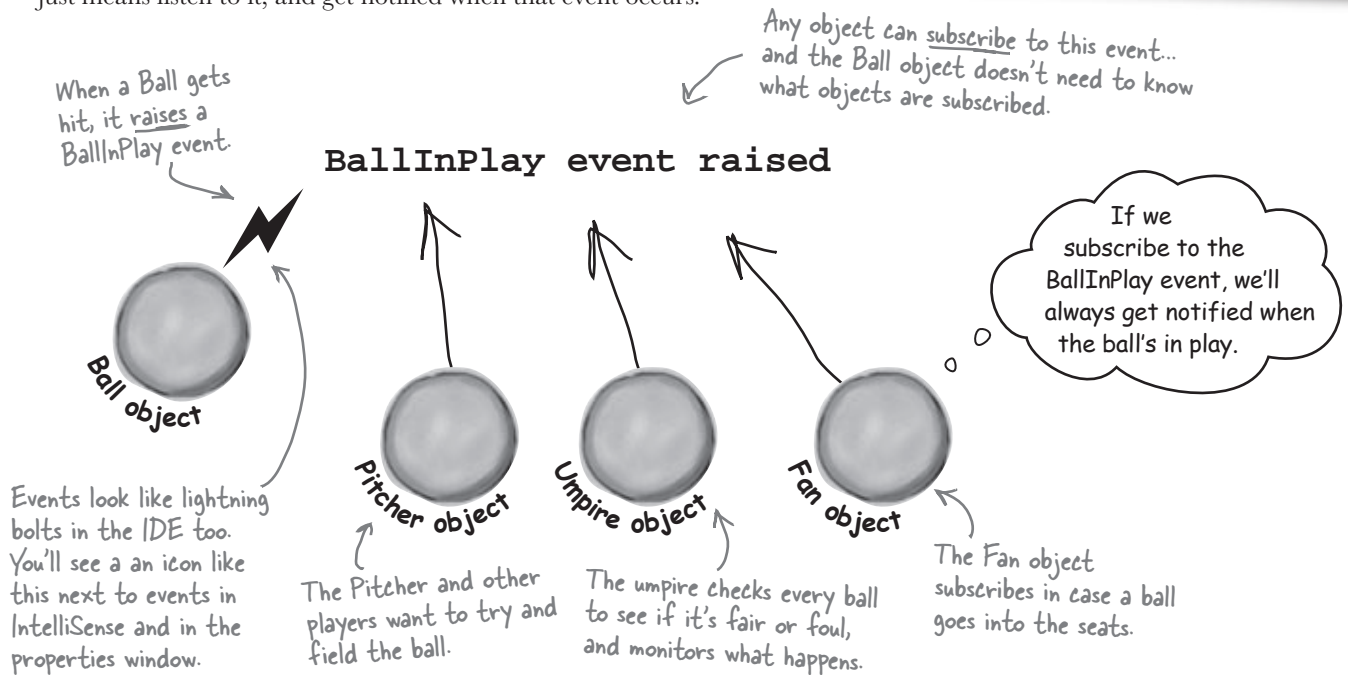

Want to **DO SOMETHING** with an event?

You need an event handler

Once your object “hears” about an event, you can set up some code to run. That code is called an **event handler**. An event handler gets information about the event, and runs every time that event occurs.

Remember, all this happens **without your intervention** at runtime. So you write code to raise an event, and then you write code to handle those events, and fire up your application. Then, whenever an event is raised, your handler kicks into action... *without you doing anything*. And, best of all, your objects have separate concerns. They're worrying about themselves, not other objects.

We've been doing this all along. Every time you click a button, an event is raised, and your code responds to that event.

One object raises its event, others listen for it...

Let's take a look at how events, event handlers, and subscription works in C#:

① First, other objects subscribe to the event

Before the `Ball` can raise its `BallInPlay` event, other objects need to subscribe to it. That's their way of saying, anytime a `BallInPlay` event occurs, we want to know about it.

Every object adds its own event handler to listen for the event—just like you add `button1_Click()` to your programs to listen for `Click` events.

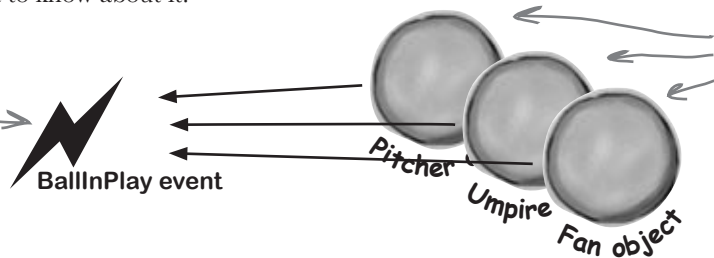

These objects are saying they want to know anytime a `BallInPlay` event is raised.

② Something triggers an event

The ball gets hit. It's time for the `Ball` object to raise a new event.



The `Ball` object starts everything rolling. It's job is to raise an event when it gets hit, and goes into play.

Sometimes we'll talk about raising an event, or firing it, or invoking it—they're all the same thing. People just use different names for it.

③ The ball raises an event

A new event gets created (we'll talk about exactly how that works in just a minute). That event also has some arguments, like the velocity of the ball, as well as its trajectory. Those arguments are attached to the event as an instance of an `EventArgs` object, and then the event is sent off, available to anyone listening for it.

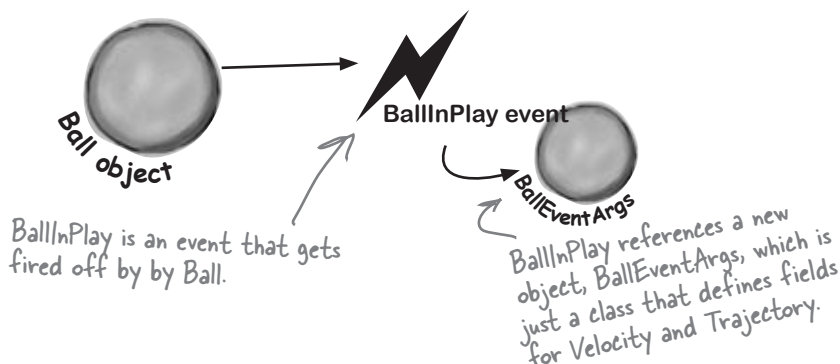

Then, the other objects handle the event

Once an event is raised, all the objects subscribed to that event get notification, and can do something:

④ Subscribers get notification

Since the Pitcher, Umpire, and Fan object subscribed to the Ball object's BallInPlay event, they all get notified—all of their event handler methods get called one after another.

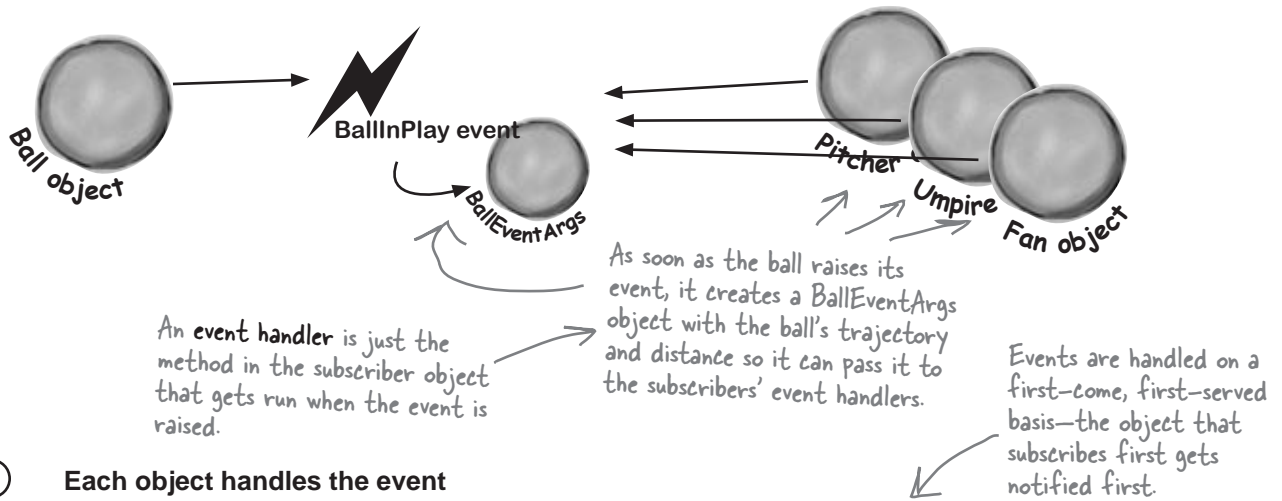

⑤ Each object handles the event

Now, Pitcher, Umpire, and Fan can all handle the BallInPlay event in their own way. But they don't all run at the same time—their event handlers get called one after another, with a reference to a BallEventArgs object as its parameter.

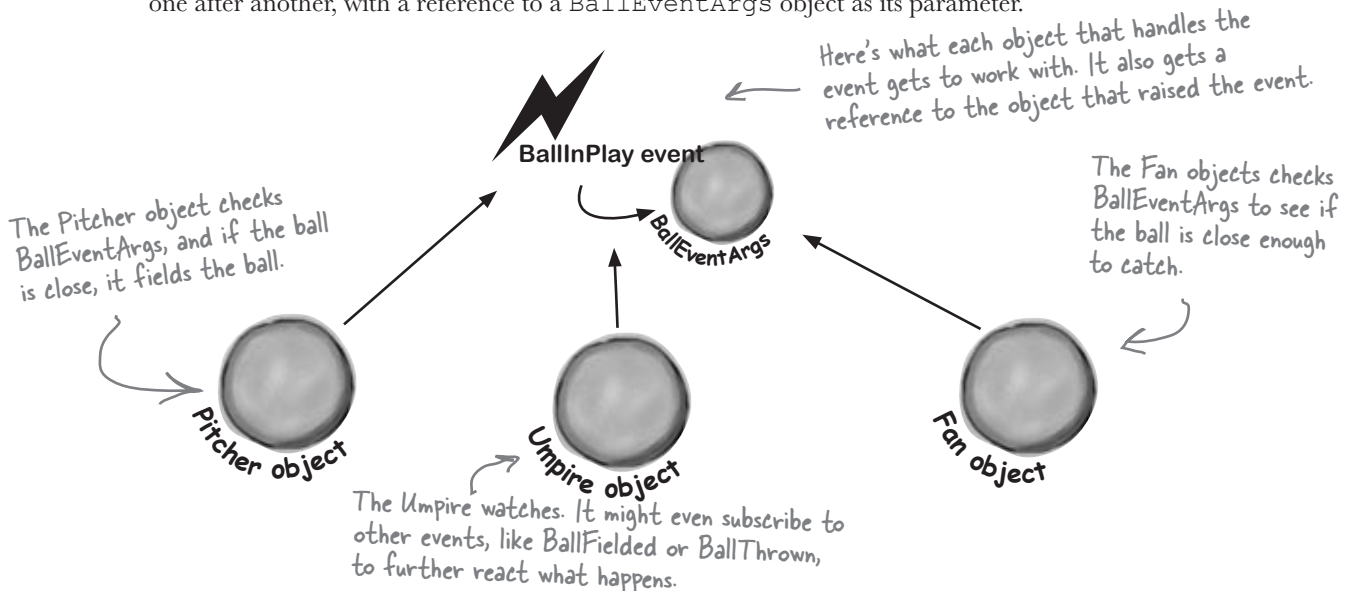

Connecting the dots

Now that you've got a handle on what's going on, let's take a closer look at how the pieces fit together. Luckily, there are only a few moving parts.

It's a good idea (although not required) for your event argument objects to inherit from EventArgs. That's an empty class—it has no public members.

It means that you can upcast your EventArgs object in case you need to send it to an event that doesn't handle it in particular.

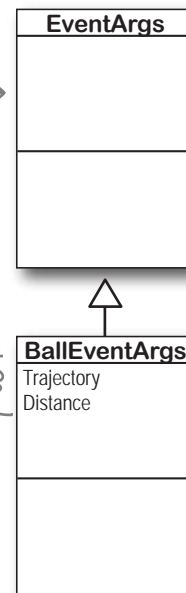

1 We need an object for the event arguments

Remember, our BallInPlay event has a few arguments that it carries along. So we need a very simple object for those arguments. .NET has a standard class for it called **EventArgs**, but that class **has no members**. Its sole purpose is to allow your event arguments object to be passed to the event handlers that use it. Here's the class declaration:

```
public class BallEventArgs : EventArgs
```

The ball will use these properties to pass information hit to the event handlers about where the ball's been hit.

2 Next we'll need to define the event in the class that'll raise it

The ball class will have a line with the **event keyword**—this is how it informs other objects about the event, so they can subscribe to it. This line can be anywhere in the class—it's usually near the property declarations. But as long as it's in the Ball class, other objects can subscribe to a ball's event. It looks like this:

```
public event EventHandler BallInPlay;
```

Events are usually public. This event is defined in the Ball class, but we'll want Pitcher, Umpire, etc., to be able to reference it. You could make it private if you only wanted other instances of the same class to subscribe to it.

After the event keyword comes EventHandler. That's not a reserved C# keyword—it's defined as part of .NET. The reason you need it is to tell the objects subscribing to the event what their event handler methods should look like.

When you use EventHandler, you're telling other methods that their event handlers need to take two parameters, an object named sender and an EventArgs reference named e. sender is a reference to the object that raised the event, and e is a reference to an EventArgs object.

③ The subscribing classes need event handler methods

Every object that has to subscribe to the Ball's BallInPlay event needs to have an event handler. You already know how event handlers work—every time you added a method to handle a Button's Click event or a NumericUpDown's ValueChanged event, the IDE added an **event handler method** to your class. The Ball's BallInPlay event is no different, and an event handler for it should look pretty familiar:

```
void ball_BallInPlay(object sender, EventArgs e)
```

There's no C# rule that says your event handlers need to be named a certain way, but there's a pretty standard naming convention: the name of the object reference, followed by an underscore, followed by the name of the event.

The BallInPlay event declaration listed its event type as EventHandler, which means that it needs to take two parameters—an object called sender and an EventArgs called e—and have no return value.

↑
The class that has this particular event handler method has a Ball reference variable called ball, so its BallInPlay event handler starts with "ball_", followed by the name of the event being handled, "BallInPlay".

④ Each individual object subscribes to the event

Once we've got the event handler set up, the various Pitcher, Umpire, ThirdBaseman, and Fan objects need to hook up their own event handlers. Each one of them will have its own specific ball_BallInPlay method that responds differently to the event. So if there's a Ball object reference variable or field called ball, then the += operator will hook up the event handler:

```
ball.BallInPlay += new EventHandler(ball_BallInPlay);
```

This tells C# to hook the event handler up to the BallInPlay event of whatever object the ball reference is pointing to.

↑
The += operator tells C# subscribe an event handler to an event.

↑
This part specifies which event handler method to subscribe to the event.

↑
The event handler method's signature (its parameters and return value) has to match the one defined by EventHandler or the program won't compile.

Turn the page, there's a little more... →

5 A Ball object raises its event to notify subscribers that it's in play

Now that the events are all set up, the Ball can **raise its event** in response to something else that happens in the simulator. Raising an event is easy—it just calls the BallInPlay event.

```
if (BallInPlay != null)
    BallInPlay(this, e);
```

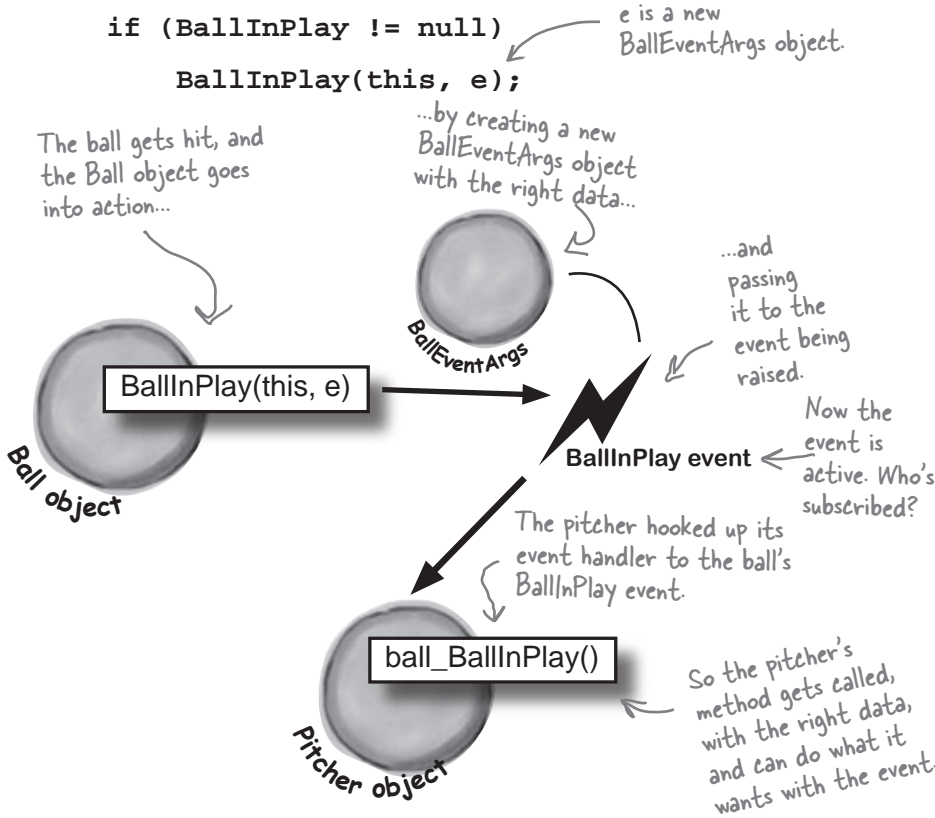

Watch it!

If you raise an event with no handlers, it'll throw an exception.

If no other objects have added their event handlers to an event, it'll be null. So always check to make sure your event handler isn't equal to null before you raise it. If you don't, it'll throw a NullReferenceException.

Use a standard name when you add a method to raise an event

Take a minute and go the code for any form and type the keyword override any place you'd declare a method. As soon as you press space, an IntelliSense window pops up:

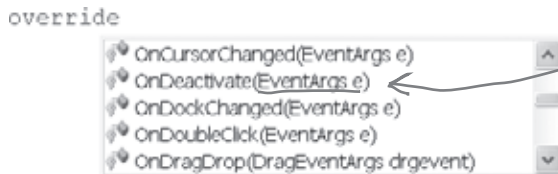

Notice how each of these methods takes an EventArgs as a parameter? They all pass that parameter on to the event when they raise it.

There are a huge number of events that a Form object can raise, and every one of them has its own method that raises it. The form's OnDoubleClick() raises the DoubleClick event, and that's the whole reason it's there. So the Ball event will follow the same convention: we'll make sure it **has a method called OnBallInPlay** that takes a BallEventArgs object as a parameter. The baseball simulator will call that method any time it needs the ball to raise its BallInPlay event—so when the simulator detects that the bat hit the ball, it'll create a new instance of BallEventArgs with the ball's trajectory and distance and pass it to OnBallInPlay().

there are no Dumb Questions

Q: Why do I need to include the word `EventHandler` when I declare an event? I thought the event handler was what the other objects used to subscribe to the events.

A: That's true—when you need to subscribe to an event, you write a method called an event handler. But did you notice how we used `EventHandler` in the the event declaration (step #2) *and* the in line to subscribe the event handler to it (step #4)? What `EventHandler` does is it defines the **signature** of the event—it tells the objects subscribing to the event exactly how they need to define their event handler methods. Specifically, it says that if you want to subscribe a method to this event, it needs to take two parameters (an `object` and an `EventArgs` reference) and have a `void` return value.

Q: What happens if I try to use a method that doesn't match the ones that are defined by `EventHandler`?

A: Then your program won't compile. The compiler will make sure that you don't ever accidentally subscribe an incompatible event handler method to an event. That's why the standard event handler, `EventHandler`, is so useful—as soon as you see it, you know exactly what your event handler method needs to look like.

Q: Wait, “standard” event handler? There are other kinds of event handlers?

A: Yes! Your events don't *have to* send an object and an `EventArgs`. In fact, they can send anything at all—or nothing at all! Look at the last line in the IntelliSense window on the bottom on the facing page. Notice how the `OnDragDrop` method takes a `EventArgs` reference instead of an `EventArgs` reference? `EventArgs` inherits from `EventArgs`, just like `BallEventArgs` does. The form's `DragDrop` event doesn't use `EventHandler`. It uses something else, `EventArgs`, and if you want to handle it, your event handler method needs to take an object and a `EventArgs` reference.

The parameters of the event are defined by something called a *delegate*—`EventHandler` and `EventArgs` are two examples of delegates. But we'll talk more about that in a minute.

Q: So I can probably have my event handlers return something other than `void`, too, right?

A: Well, you can, but it's often a bad idea. If you don't return `void` from your handler, you can't *chain* event handlers. That means you can't connect more than one handler to each event. Since chaining is a handy feature, you'd do best to always return `void` from your event handlers.

Q: Chaining? What's that?

A: It's how more than one object can subscribe to the same event—they chain their event handlers onto the event, one after

another. We'll talk a lot more about that in a minute, too.

Q: Is that why I used `+=` when when I added my event handler? Like I'm somehow adding a new handler to existing handlers?

A: Exactly! Anytime you add an event handler, you want to use `+=`. That way, your handler doesn't replace existing handlers. It just becomes one in what may be a very long chain of other event handlers, all of which are listening to the same event.

Q: Why does the ball use “this” when it raises the `BallInPlay()` event?

A: Because that's the first parameter of the standard event handler. Have you noticed how every `Click` event handler method has a parameter “object sender”? That parameter is a **reference to the object that's raising the event**. So if you're handling a button click, `sender` points to the button that was clicked. And if you're handling a `BallInPlay` event, `sender` will point to the `Ball` object that's in play—and the ball sets that parameter to `this` when it raises the event.

A SINGLE event is always raised by a SINGLE object.

But a SINGLE event can be responded to by MULTIPLE objects.

The IDE creates event handlers for you automatically

Most programmers follow the same convention for naming their event handlers. If there's a `Ball` object that has a `BallInPlay` event, and the name of the reference holding the object is called `ball`, then the event handler would typically be named `ball_BallInPlay()`. That's not a hard-and-fast rule, but if you write your code like that, it'll be a lot easier for other programmers to read.

Luckily, the IDE makes it really easy to name your event handlers properly. It has a feature that **automatically adds event handler methods for you** when you're working with a class that raises an event. It shouldn't be too surprising that the IDE can do this for you—after all, this is exactly what it does when you double-click on a button in your form.



1 Start a new Windows application and add the `Ball` and `BallEventArgs`

Here's the `Ball` class:

```
public class Ball {
    public event EventHandler BallInPlay;
    public void OnBallInPlay(BallEventArgs e) {
        if (BallInPlay != null)
            BallInPlay(this, e);
    }
}
```

And here's the `BallEventArgs` class:

```
public class BallEventArgs : EventArgs {
    public int Trajectory { get; private set; }
    public int Distance { get; private set; }
    public BallEventArgs(int Trajectory, int Distance) {
        this.Trajectory = Trajectory;
        this.Distance = Distance;
    }
}
```

2 Start adding the `Pitcher`'s constructor

Add a new `Pitcher` class to your project. Then give it a constructor that takes a `Ball` reference called `ball` as a parameter. There will be one line of code in the constructor to add its event handler to `ball.BallInPlay`. Start typing the statement, but **don't type += yet**.

```
public Pitcher(Ball ball) {
    ball.BallInPlay
}
```

3 Type += and the IDE will finish the statement for you

As soon as you type += in the statement, the IDE displays a very useful little box:

```
public Pitcher(Ball ball) {
    ball.BallInPlay +=
} new EventHandler(ball_BallInPlay); (Press TAB to insert)
```

As soon as you press the tab key, the IDE will finish the statement for you. It'll look like this:

```
public Pitcher(Ball ball) {
    ball.BallInPlay += new EventHandler(ball_BallInPlay);
}
```

When you double-click on a button in the form designer, the IDE does the exact same trick—adding an event handler automatically—except that it adds the code to the form's `InitializeComponent()` method in the `Form1.Designer.cs` file instead of just adding it to the end of the class file.

4 The IDE will add your event handler, too

You're not done—you still need to add a method to chain onto the event. Luckily, the IDE takes care of that for you, too.

```
new EventHandler(ball_BallInPlay);
Press TAB to generate handler 'bal_BallInPlay' in this class
```

Hit the tab key again to make the IDE add this event handler method to your `Pitcher` class. The IDE will always follow the `objectName_HandlerName()` convention:

```
void ball_BallInPlay(object sender, EventArgs e) {
    throw new NotImplementedException();
}
```

The IDE always fills in this `NotImplementedException()` as a placeholder so if you run the code it'll throw an exception that tells you that you still need to implement something it filled in automatically.

5 Finish the pitcher's event handler

Now that you've got the event handler's skeleton added to your class, fill in the rest of its code. The pitcher should catch any low balls, otherwise he covers first base.

```
void ball_BallInPlay(object sender, EventArgs e) {
    if (e is BallEventArgs) {
        BallEventArgs ballEventArgs = e as BallEventArgs;
        if ((ballEventArgs.Distance < 95) && (ballEventArgs.Trajectory < 60))
            CatchBall();
        else
            CoverFirstBase();
    }
}
```

Since `BallEventArgs` is a subclass of `EventArgs`, we'll downcast it using the `as` keyword so we can use its properties.

You'll add these methods in a minute.



Exercise

It's time to put what you've learned so far into practice. Your job is to complete the Ball and Pitcher classes, add a Fan class, and make sure they all work together with a very basic version of your baseball simulator.

1 Complete the Pitcher class.

Below is what we've got for Pitcher. Add the CatchBall () and CoverFirstBase () methods. Both should print out that the catcher has either caught the ball, or run to first base.

```
public class Pitcher {
    public Pitcher(Ball ball) {
        ball.BallInPlay += new EventHandler(ball_BallInPlay);
    }

    void ball_BallInPlay(object sender, EventArgs e) {
        if (e is BallEventArgs) {
            BallEventArgs ballEventArgs = e as BallEventArgs;
            if ((ballEventArgs.Distance < 95) && (ballEventArgs.Trajectory < 60))
                CatchBall();
            else
                CoverFirstBase();
        }
    }
}
```

You'll need to implement these two methods to write a line of output to the console.



2 Write a Fan class.

Create another class called Fan. Fan should also subscribe to the BallInPlay event in its constructor. The fan's event handler should see if the distance is greater than 400 feet and the trajectory is greater than 30 (a home run), and grab for a glove to try and catch the ball if it is. If not, the fan should scream and yell. Write out what's going on with the fan to the console.

Look at the output window on the facing page to see exactly what it should print.



4 Build a very simple simulator.

Create a new application. The application should have two NumericUpDown controls: one for the ball's distance, and one for its trajectory. Add a button, labeled "Play ball!" When "Play ball!" is clicked, a ball is hit with the values in the two NumericUpDowns. Your form should look something like this:

The value for trajectory can range from 0 to 100, so set its Minimum property to 0, Maximum to 100 and Value to 20.

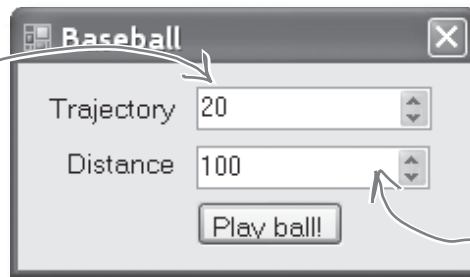

Don't forget to cast the value properties to ints before you use them.

The Distance can range from 0 to 500, with a default value of 100.

5 Create the following output.

See if you can make your simulator generate this output with three successive balls put into play. Write down the values you used to get the result below:

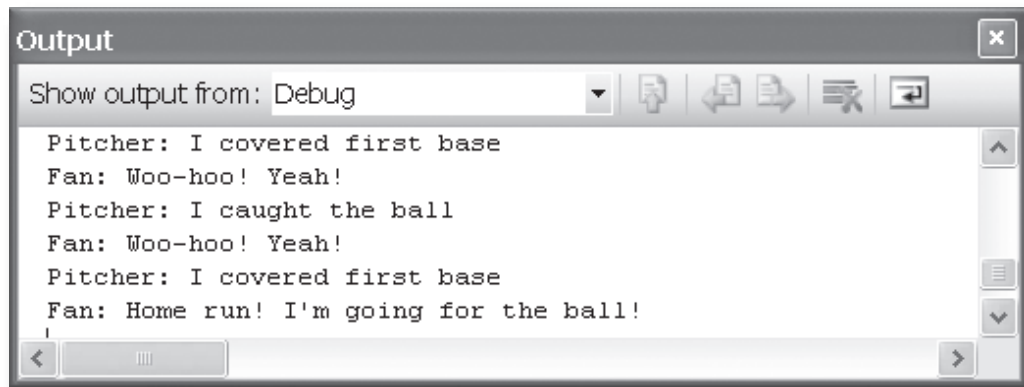

Ball 1:

Trajectory:
Distance:

Ball 2:

Trajectory:
Distance:

Ball 3:

Trajectory:
Distance:



Exercise Solution

It's time to put what you've learned so far into practice. Your job is to complete the Ball and Pitcher classes, add a Fan class, and make sure they all work together with a very basic version of your baseball simulator.

```

public class Ball
{
    public event EventHandler BallInPlay;
    public void OnBallInPlay(BallEventArgs e)
    {
        if (BallInPlay != null)
            BallInPlay(this, e);
    }
}

public class BallEventArgs : EventArgs {
    public int Trajectory { get; private set; }
    public int Distance { get; private set; }
    public BallEventArgs(int Trajectory, int Distance)
    {
        this.Trajectory = Trajectory;
        this.Distance = Distance;
    }
}

public class Fan {
    public Fan(Ball ball)
    {
        ball.BallInPlay += new EventHandler(ball_BallInPlay);
    }

    void ball_BallInPlay(object sender, EventArgs e)
    {
        if (e is BallEventArgs) {
            BallEventArgs ballEventArgs = e as BallEventArgs;
            if (ballEventArgs.Distance > 400 && ballEventArgs.Trajectory > 30)
                Console.WriteLine("Fan: Home run! I'm going for the ball!");
            else
                Console.WriteLine("Fan: Woo-hoo! Yeah!");
        }
    }
}
    
```

The `OnBallInPlay()` method just raises the `BallInPlay` event—but it has to check make sure it's not null, otherwise it'll throw an exception.

Read-only automatic properties work really well in event arguments because the event handlers only read the data passed to them.

The `Fan` object's constructor chains its event handler onto the `BallInPlay` event.

The fan's `BallInPlay` event handler looks for any ball that's high and long.

```

public class Pitcher {
    public Pitcher(Ball ball) {
        ball.BallInPlay += new EventHandler(ball_BallInPlay);
    }
    void ball_BallInPlay(object sender, EventArgs e) {
        if (e is BallEventArgs) {
            BallEventArgs ballEventArgs = e as BallEventArgs;
            if ((ballEventArgs.Distance < 95) && (ballEventArgs.Trajectory < 60))
                CatchBall();
            else
                CoverFirstBase();
        }
    }
    private void CatchBall() {
        Console.WriteLine("Pitcher: I caught the ball");
    }
    private void CoverFirstBase() {
        Console.WriteLine("Pitcher: I covered first base");
    }
}

```

You already have the pitcher's BallInPlay event handler. It looks for any low balls.

```

public partial class Form1 : Form {
    Ball ball = new Ball();
    Pitcher pitcher;
    Fan fan;

    public Form1() {
        InitializeComponent();
        pitcher = new Pitcher(ball);
        fan = new Fan(ball);
    }

    private void playBall_Click(object sender, EventArgs e) {
        BallEventArgs ballEventArgs = new BallEventArgs(
            (int)trajectory.Value, (int)distance.Value);
        ball.OnBallInPlay(ballEventArgs);
    }
}

```

The form needs one ball, one fan, and one pitcher. It hooks the fan and pitcher up to the ball in its constructor.

When the button's clicked, the form tells the pitcher to pitch the ball to the batter, which tells the ball to fire off its BallInPlay event, which calls the event handlers in the pitcher and fan objects.

Here are the values we used to get the output. Yours might be a little different.

Ball 1:
 Trajectory: 75
 Distance: 105

Ball 2:
 Trajectory: 48
 Distance: 80

Ball 3:
 Trajectory: 40
 Distance: 435

The forms you've been building all use events

Every time you've created a button, double-clicked on it in the designer, and written code for a method like `button1_Click()`, you've been working with events.



- 1 Create a new Windows Application project. Go to the Properties window for the form. There are icons at the top of the window—click on the one that's got a lightning bolt icon on it. That will bring up **the events page in the Properties window**:

You can see all of the events for a control: just click on it and then click on this events button in the properties window.

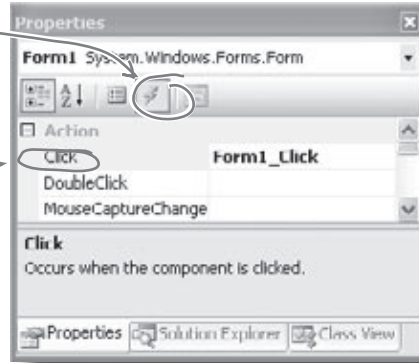

Scroll down to Click and double-click on the word "Click". When you do, the IDE will add a new click event handler to your form that gets fired every time you click on it. And it'll add a line to `Form1.Designer.cs` to hook the event handler up to the event.

You can create an event that will fire every time someone clicks on the form by selecting `Form1_Click` next to Click in the events window.

- 2 Double-click on the "Click" row in the events page. The IDE will automatically add an event handler method to your form called `Form1_Click`. Add this line of code to it:

```
private void Form1_Click(object sender, EventArgs e) {
    MessageBox.Show("You just clicked on the form");
}
```

- 3 Visual Studio did more than just write a little method declaration for you, though. It also hooked the event handler up to the Form objects Click event. Open up `Form1.Designer.cs` and use the Quick Find feature in the IDE to search for the text `Form1_Click` in the current project. You'll find this line of code:

```
this.Click += new System.EventHandler(this.Form1_Click);
```

Now run the program and make sure your code works!



Event handlers always need to be "hooked up".

*If you drag a button onto your form and add a method called `button1_Click()`, that has the right parameters, but **isn't registered to listen to your button**, the method won't ever get called. Double-click on the button in the designer—the IDE will see the default event handler name is taken, so it'll add an event handler for the button called `button1_Click_1()`.*

One event, multiple handlers

Here's a really useful thing that you can do with events: you can **chain** them so that one event or delegate calls many methods, one after another. Let's add a few buttons to your application to see how it works.

- 4 Add these two methods to your form:

```
private void SaySomething(object sender, EventArgs e) {
    MessageBox.Show("Something");
}
private void SaySomethingElse(object sender, EventArgs e) {
    MessageBox.Show("Something else");
}
```

- 5 Now add two buttons to your form. Double-click on each button to add its event handler. Here's the code for both event handlers:

```
private void button1_Click(object sender, EventArgs e) {
    this.Click += new EventHandler(SaySomething);
}
private void button2_Click(object sender, EventArgs e) {
    this.Click += new EventHandler(SaySomethingElse);
}
```

- 6 Now run your program and do this:

- ★ **Click the form**—you'll see a message box pop up that says, "You just clicked on the form".
- ★ Now **click button1** and then **click on the form again**. You'll see two message boxes pop up: "You just clicked on the form" and then "Something".
- ★ **Click button2 twice** and then **click on the form again**. You'll see four message boxes: "You just clicked on the form", "Something", "Something else", and "Something else".

So what happened?

Every time you clicked one of the buttons, you chained another method—either `Something()` or `SomethingElse()`—onto the form's `Click` event. You can keep clicking the buttons, and they'll keep **chaining the same methods** onto the event. The event doesn't care how many methods are chained on, or even if the same method is in the chain more than once. It'll just call them all every time the event fires, one after another, in the order they were added.

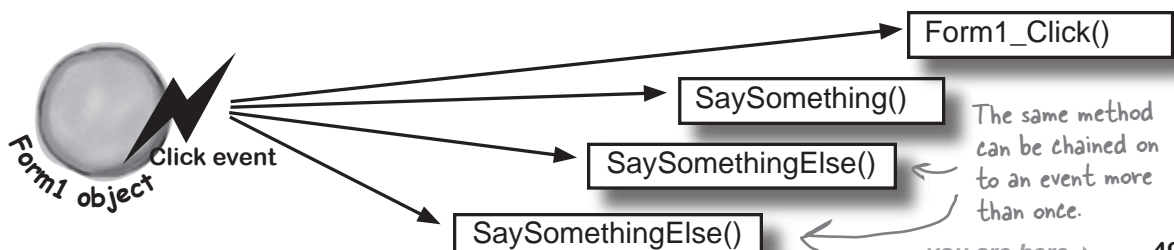

there are no Dumb Questions

Q: When I added a new event handler to the `Pitcher` object, why did the IDE make it throw an exception?

A: It added code to throw a `NotImplementedException` to remind you that you still need to implement code there. That's a really useful exception, because you can use it as a placeholder just like the IDE did. For example, you'll typically use it when you need to build the skeleton of a class but you don't want to fill in all the code yet. That way, if your program throws that exception, you know it's because you still need to finish the code, and not because your program is broken.

When you click these buttons, they chain different event handlers onto the form's `Click` event.

That means you won't see anything when you click the buttons! You'll need to click on the form, because the buttons change the form's behavior by modifying its `Click` event.

Connecting event senders with event receivers

One of the trickiest things about events is that the **sender** of the event has to know what kind of event to send—including the arguments to pass to the event. And the **receiver** of the event has to know about the return type and the arguments its handler methods must use.

But—and here’s the tricky part—you can’t tie the sender and receiver *together*. You want the sender to send the event and *not worry about who receives it*. And the receiver cares about the event, *not the object that raised the event*. So both sender and receiver focus on the event, not each other.

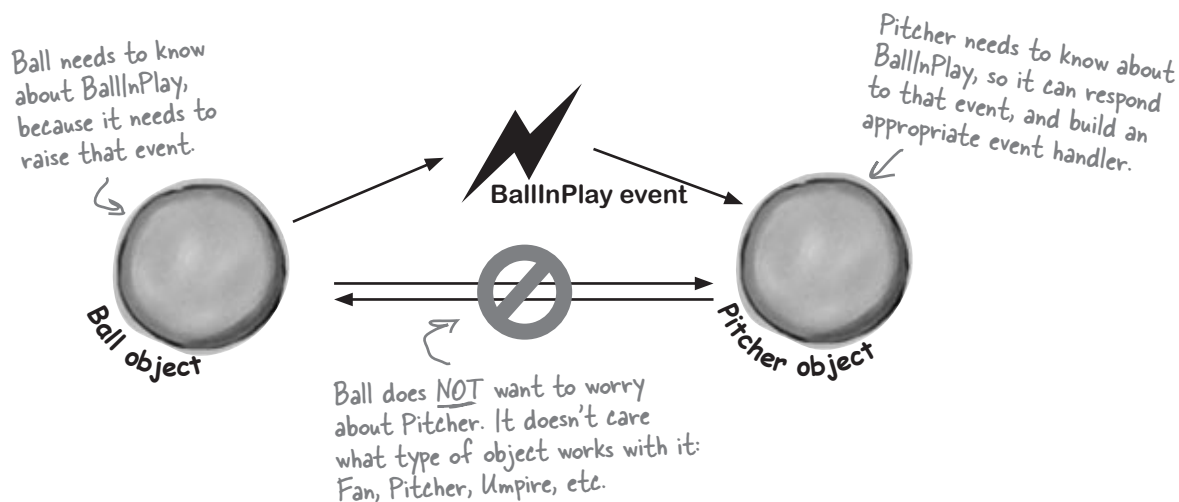

“My people will get in touch with your people.”

You know what this code does:

```
Ball currentBall;
```

It creates a **reference variable** that can point to any Ball object. It’s not tied to a single Ball. Instead, it can point to any ball object—or it can be null, and not point to anything at all.

An event needs a similar kind of reference—except instead of pointing to an object, it needs one that **points to a method**. Every event needs to keep track of a list of methods that are subscribed to it. You’ve already seen that they can be in other classes, and they can even be private. So how does it keep track of all of the event handler methods that it needs to call?

A delegate STANDS IN for an actual method

One of the most useful aspects of events is that when an event fires, it **has no idea** whose event handler methods it's calling. Anyone who happens to subscribe to an event gets his event handler called. So how does the event manage that?

It uses a C# type called a **delegate**. A delegate lets you create a reference variable, but instead of referring to an instance of a class, it **refers to a method inside a class**.

You've actually already been using delegates throughout this chapter! When you created the BallInPlay event, you used EventHandler. Well, an EventHandler is just a delegate. If you right-click on EventHandler in the IDE and select "Go to definition", this is what you'll see (try it yourself):

When you create a delegate, all you need to do is specify the signature of methods that it can point to.

So this delegate can be used to reference any method that takes an object and an EventArgs and has no return value.

```
public delegate void EventHandler(object sender, EventArgs e);
```

This specifies the return value of the delegate's signature—which means an EventHandler can only point to methods with void return values.

The name of this delegate is EventHandler.



A delegate adds a new type to your project

When you add a delegate to your project, you're adding a **delegate type**. And when you use it to create a field or variable, you're creating an **instance** of that delegate type. **So create a new project**. Then add a new class file to the project called ReturnsAString.cs. But instead of putting a class inside it, add a single line:

```
public delegate string ReturnsAString();
```

ReturnsAString is a delegate type that you've added to your project. Now you can use it to declare variables and fields.

Go to the form code and add this field to the form:

```
ReturnsAString someMethod;
```

someMethod is an instance of the delegate type ReturnsAString.

Now build your program—it compiles! (It gets a warning because you never used that field—that's okay.) As soon as you added your new delegate to the program, it created a new type called ReturnsAString. If you use that type to declare a variable, you can set that variable equal to any method that takes no parameters and returns a string. Try it out—add this method to your code:

```
private string HiThere() {
    return "Hi there!";
}
```

This method's signature matches ReturnsAString.

Add a button that has these three lines. Click it and see what happens:

```
someMethod = new ReturnsAString(HiThere);
string message = someMethod();
MessageBox.Show(message);
```

You can set someMethod just like any other variable. But when you call it like a method, it calls whatever method it happens to point to.

del-e-gate, noun.
a person sent or authorized to represent others. *The president sent a **delegate** to the summit.*

Delegates in action

There's nothing mysterious about delegates—in fact, they don't take much code at all to use. Let's use them to help a restaurant owner sort out his top chef's secret ingredients.



1 Create a new Windows project and add a delegate

Delegates usually appear outside of any other classes, so add a new class file to your project and call it `GetSecretIngredient.cs`. It will have exactly one line of code in it:

```
public delegate string GetSecretIngredient(int amount);
```

This delegate can be used to create a variable that can point to any method that takes one `int` parameter and returns a `string`.

2 Add a class for the first chef, Suzanne

`Suzanne.cs` will hold a class that keeps track of the first chef's secret ingredient. It has a private method called `SuzannesSecretIngredient()` with a signature that matches `GetSecretIngredient`. But it also has a read-only property—and check out that property's type. It returns a `GetSecretIngredient`. So other objects can use that property to get a reference to her `SuzannesIngredientList()` method.

```
public class Suzanne {
    public GetSecretIngredient MySecretIngredientMethod {
        get {
            return new GetSecretIngredient(SuzannesSecretIngredient);
        }
    }
    private string SuzannesSecretIngredient(int amount) {
        return amount.ToString() + " ounces of cloves";
    }
}
```

Suzanne's secret ingredient method takes an int called amount and returns a string that describes her secret ingredient.

3 Then add a class for the second chef, Amy

Amy's method works a lot like Suzanne's:

```
public class Amy {
    public GetSecretIngredient AmysSecretIngredientMethod {
        get {
            return new GetSecretIngredient(AmysSecretIngredient);
        }
    }
    private string AmysSecretIngredient(int amount) {
        if (amount < 10)
            return amount.ToString()
                + " cans of sardines -- you need more!";
        else
            return amount.ToString() + " cans of sardines";
    }
}
```

Amy's secret ingredient method also takes an int called amount and returns a string, but it returns a different string from Suzanne's.

Amy's GetSecretIngredient property returns a new instance of the GetSecretIngredient delegate that's pointing to her secret ingredient method.

4 Create a new Windows project and add a delegate

Build this form. 

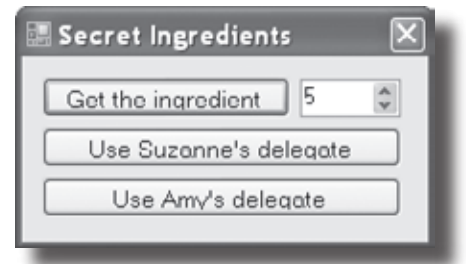

Here's the code for the form:

```
GetSecretIngredient ingredientMethod = null;
Suzanne suzanne = new Suzanne();
Amy amy = new Amy();

private void useIngredient_Click(object sender, EventArgs e) {
    if (ingredientMethod != null)
        Console.WriteLine("I'll add " + ingredientMethod((int)amount.Value));
    else
        Console.WriteLine("I don't have a secret ingredient!");
}

private void getSuzanne_Click(object sender, EventArgs e) {
    ingredientMethod = new GetSecretIngredient(suzanne.MySecretIngredientMethod);
}

private void getAmy_Click(object sender, EventArgs e) {
    ingredientMethod = new GetSecretIngredient(amy.AmysSecretIngredientMethod);
}
```

5 Use the debugger to explore how delegates work

You've got a great tool—the IDE's debugger—that really help you get a handle on how delegates work. Do the following steps:

- ★ Start by running your program. First click the “Get the ingredient” button—it should write a line to the console that says, “I don't have a secret ingredient.”
- ★ Click the “Use Suzanne's delegate” button—that takes the form's ingredientMethod field (which is a GetSecretIngredient delegate) and set it equal to whatever Suzanne's GetSecretIngredient property returns. That property returns a new instance of the GetSecretIngredient type that's pointing to the SuzannesSecretIngredient() method.
- ★ Click the “Get the ingredient” button again. Now that the form's ingredientMethod field is pointing to SuzannesSecretIngredient(), it calls that, passing it the value in the numericUpDown control and writing its output to the console.
- ★ Click the “Use Amy's delegate” button. It uses the Amy.GetSecretIngredient property to set the form's ingredientMethod field to point to the AmysSecretIngredient() method.
- ★ Click the “Get the ingredient” method one more time. Now it calls Amy's method.
- ★ Now **use the debugger** to see exactly what's going on. Place a breakpoint on the first line of each of the three methods in the form. Then **restart the program** (which resets the ingredientMethod so that it's equal to null), and start over with the above five steps. Use the Step Into (F11) feature of the debugger to step through every line of code. Watch what happens when you click “Get the ingredient”. It steps right into the Suzanne and Amy classes, depending on which method the ingredientMethod field is pointing to.

Pool Puzzle



Your **job** is to take snippets from the pool and place them into the blank lines in the code. You can use the same snippet more than once, and you won't need to use all the snippets. Your **goal** is to complete the code for a form that writes this output to the console when its **button1** button is clicked.

Output

Fingers is coming to get you!

Note: each thing from the pool can be used more than once

```
public Form1() {
    InitializeComponent();

    this._____ += new EventHandler(Minivan);
    this._____ += new EventHandler(_____);
}

void Towtruck(object sender, EventArgs e) {
    Console.Write("is coming ");
}

void Motorcycle(object sender, EventArgs e) {
    button1._____ += new EventHandler(_____);
}

void Bicycle(object sender, EventArgs e) {
    Console.WriteLine("to get you!");
}

void _____(object sender, EventArgs e) {
    button1._____ += new EventHandler(Dumptruck);
    button1._____ += new EventHandler(_____);
}

void _____(object sender, EventArgs e) {
    Console.Write("Fingers ");
}
}
```

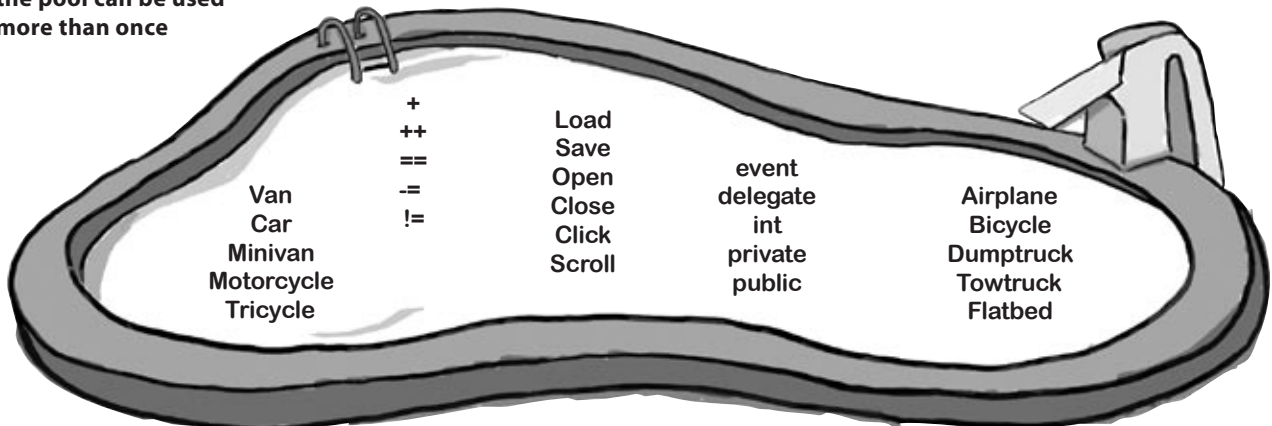

Any object can subscribe to a public event...

Suppose we add a new class to our simulator, a `Bat` class, and that class adds a `HitTheBall` event into the mix. Here's how it works: if the simulator detects that the player hit the ball, it calls the `Bat` object's `OnHitTheBall()` method, which raises a `HitTheBall` event.

So now we can add a `bat_HitTheBall` method to the `Ball` class that subscribes to the `Bat` object's `HitTheBall` event. Then when the ball gets hit, its own event handler calls its `OnBallInPlay()` method to raise its own event, `BallInPlay`, and the chain reaction begins. Fielders field, fans scream, umpires yell... we've got a ball game.

Now its event handler can take information about how hard the swing was, figure out the distance and trajectory, and raise a `BallInPlay` event.

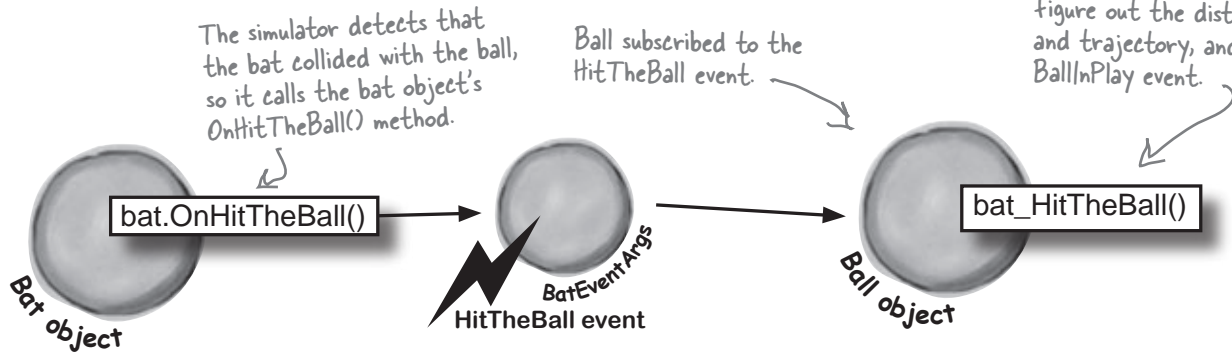

...but that's not always a good thing!

There's only ever going to be one ball in play at any time. But if the `Bat` object uses an event to announce to the ball that it's been hit, then any `Ball` object can subscribe to it. And that means we've set ourselves up for a nasty little bug—what happens if a programmer accidentally adds three more `Ball` objects? Then the batter will swing, hit, and **four different balls will fly** out into the field!

Uh-oh! These balls were supposed to be held in reserve in case the first one was hit out of the park.

But a careless programmer subscribed them all to the bat's `HitTheBall` event... so when the bat hit the ball that the pitcher threw, all four of them flew out into the field!

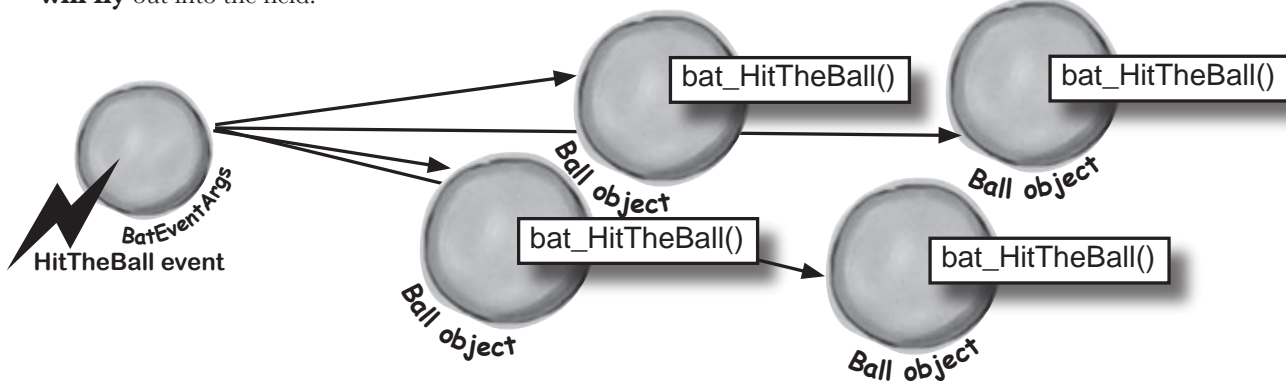

The Case of the Golden Crustacean

Henry “Flatfoot” Hodgkins is a TreasureHunter. He’s hot on the trail of one of the most prized possessions in the rare and unusual aquatic-themed jewelry markets: a jade-encrusted translucent gold crab. But so are lots of other TreasureHunters. They all got a reference to the same crab in their constructor, but Henry wants to claim the prize **first**.

In a stolen set of class diagrams, Henry discovers that the GoldenCrab class raises a RunForCover event every time anyone gets close to it. Even better, the event includes NewLocationArgs, which detail where the crab is moving to. But none of the other treasure hunters know about the event, so Henry figures he can cash in.

Henry adds code to his constructor to register his treasure_RunForCover() method as an event handler for the RunForCover event, on the crab reference he’s got. Then, he sends a lowly underling after the crab, knowing it will run away, hide, and raise the RunForCover event—giving Henry’s treasure_RunForCover() method all the information he needs.

Everything goes according to plan, until Henry gets the new location and rushes to grab the crab. He’s stunned to see three other TreasureHunters already there, fighting over the crab.

How did the other treasure hunters beat Henry to the crab?

—————> **Answers on page 511.**

Five Minute Mystery



The constructor chains two event handlers onto the load events. They get fired off as soon as the form is loaded.

```
public Form1() {
    InitializeComponent();
    this.Load += new EventHandler(Minivan);
    this.Load += new EventHandler(Motorcycle);
}

void Towtruck(object sender, EventArgs e) {
    Console.WriteLine("is coming ");
}

void Motorcycle(object sender, EventArgs e) {
    button1.Click += new EventHandler(Bicycle);
}

void Bicycle(object sender, EventArgs e) {
    Console.WriteLine("to get you!");
}

void Minivan(object sender, EventArgs e) {
    button1.Click += new EventHandler(Dumptruck);
    button1.Click += new EventHandler(Towtruck);
}

void Dumptruck(object sender, EventArgs e) {
    Console.WriteLine("Fingers ");
}
```

When the button is clicked, it calls the three event handlers that are chained to it.

Pool Puzzle Solution



The two Load event handlers hook up three separate event handlers to the button's Click event handler.

Use a callback instead of an event to hook up exactly one object to a delegate

Our system of events only works if we've got one Ball and one Bat. If you've got several Ball objects, and they all subscribe to the public event `HitTheBall`, then they'll all go flying when the event is raised. But that doesn't make any sense... it's really only one Ball object that got hit. We need to let the one ball that's being pitched hook itself up to the bat, but we need to do it in a way that doesn't allow any other balls to hook themselves up. And that's what a **callback** is—it's a way of using a delegate so the object that's calling it is guaranteed to only call the one method that it needs to call, and no other method can chain itself onto the delegate.

Here's how the callback will work:

- 1 The Bat will keep its delegate field private**
 The easiest way to keep the wrong Ball objects from chaining themselves onto the Bat's delegate is for the bat to make it private. That way, it has control over which Ball object's method gets called.
- 2 The Bat's constructor takes a delegate that points to a method in the ball**
 When the ball is in play, it creates the new instance of the bat, and it passes the Bat object a pointer to its `OnBallInPlay()` method. This is called a **callback method** because the Bat is using it to call back to the object that instantiated it.

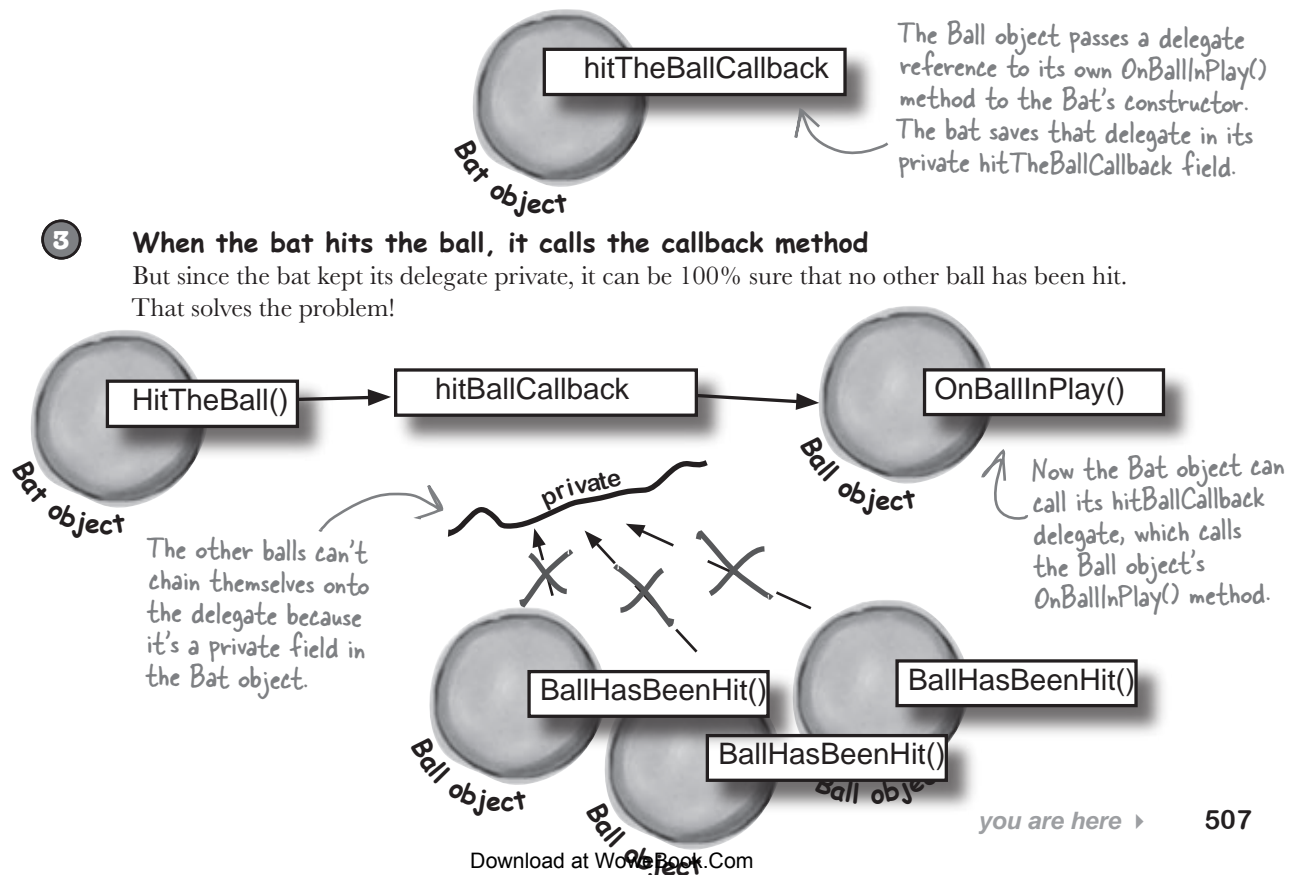

Callbacks use delegates, but NOT events

A callback is a **different way of using a delegate**. It's not a new keyword or operator. It just describes a **pattern**—a way that you use delegates with your classes so that one object can tell another object, “Notify me when this happens—and don't tell anyone else!”



1 Add another delegate to your Baseball project

Since the Bat will have a private delegate field that points to the Ball object's `OnBallInPlay()` method, we'll need a delegate that matches its signature:

```
public delegate void BatCallback(BallEventArgs e);
```

The Bat object's callback will point to a Ball object's `OnBallInPlay()` method, so the callback's delegate needs to match the signature of `OnBallInPlay()`—so it needs to take a `BallEventArgs` parameter and have a void return value.

2 Add the Bat class to the project

The Bat class is simple. It's got a `HitTheBall()` method that the simulator will call every time a ball is hit. That `HitTheBall()` method uses the `hitBallCallback()` delegate to call the ball's `OnBallInPlay()` method (or whatever method is passed into its constructor).

```
public class Bat {  
    private BatCallback hitBallCallback;  
    public Bat(BatCallback callbackDelegate) {  
        this.hitBallCallback = new BatCallback(callbackDelegate);  
    }  
    public void HitTheBall(BallEventArgs e) {  
        if (hitBallCallback != null)  
            hitBallCallback(e);  
    }  
}
```

Make sure you check every delegate to make sure it's not null, otherwise it could throw a null reference exception.

We used `=` instead of `+=` because there's no need to chain. This delegate only gets set once. But if you really feel like using `+=` instead, it'll work just fine.

3 We'll need to hook the bat up to a ball

So how does the Bat's constructor get a reference to a particular ball's `OnBallInPlay()` method? Easy—just call that Ball object's `GetNewBat()` method, which you'll have to add to Ball:

```
public Bat GetNewBat()  
{  
    return new Bat(new BatCallback(OnBallInPlay));  
}
```

We set the callback in the Bat object's constructor. But in some cases, it makes more sense to set up the callback method using a public method or property's set accessor.

The Ball's `GetNewBat()` method creates a new Bat object, and it uses the `BatCallback` delegate to pass a reference to its own `OnBallInPlay()` method to the new bat. That's the callback method the bat will use when it hits the ball.

4 Now we can encapsulate the Ball class a little better

It's unusual for one of the `On...` methods that raise an event to be `public`. You can check this for yourself—go to the form and try to call the `playBall` button's `OnClick()` event. You won't be able to, because it's `protected` (so a subclass can override it). So let's follow that pattern with our ball too, by making its `OnBallInPlay()` method `protected`:

```
protected void OnBallInPlay(BallEventArgs e)
{
    if (BallInPlay != null)
        BallInPlay(this, e);
}
```

This is a really standard pattern that you'll see over and over again when you work with .NET classes. When a .NET class has an event that gets fired, you'll almost always find a `protected` method that starts with "On".

5 All that's left to do is hook up the form

The form can't call the `Ball` object's `OnBallInPlay()` method anymore—which is exactly what we wanted. That's why we set up the `Ball.GetNewBat()` method. Now the form needs to ask the `Ball` for a new bat in order to hit the ball. And when it does, the `Ball` object will make sure that its `OnBallInPlay()` method is hooked up to the bat's callback.

```
private void playBall_Click(object sender, EventArgs e)
{
    Bat bat = ball.GetNewBat();
    BallEventArgs ballEventArgs = new BallEventArgs(
        (int)trajectory.Value, (int)distance.Value);
    bat.HitTheBall(ballEventArgs);
}
```

If the form (or the simulator) wants to hit a `Ball` object, it needs to get a new `Bat` object from that ball. The ball will make sure that the callback is hooked up to the bat. Now when the form calls the bat's `HitTheBall()` method, it calls the ball's `OnBallInPlay()` method, which fires its `BallInPlay` event.

Now **run the program**—it should work exactly like it did before. But it's now **protected** from any problems that would be caused by more than one ball listening for the same event.

But don't take our word for it—pop it open in the debugger!

BULLET POINTS

- When you add a delegate to your project, you're **creating a new type** that stores references to methods.
- Events use delegates to notify objects that actions have occurred.
- Objects subscribe to an object's event if they need to react to something that happened in that object.
- An `EventHandler` is a kind of delegate that's really common when you work with events.
- You can chain several event handlers onto one event. That's why you use `+=` to assign an handler to an event.
- Always check that an event or delegate is not null before you use it to avoid a `NullReferenceException`.
- All of the controls in the toolbox use events to make things happen in your programs.
- When one object passes a reference to a method to another object so it—and only it—can return information, it's called a callback.
- Events let any method subscribe to your object's events anonymously, while callbacks let your objects exercise more control over which delegates they accept.
- Both callbacks and events use delegates to reference and call methods in other objects.
- The debugger is a really useful tool to help you understand how events, delegates, and callbacks work. Take advantage of it!

there are no Dumb Questions

Q: How are callbacks different from events?

A: Events are part of C#. They're a way for one object to announce to other objects that something specific has happened. When one object publishes an event, any number of other objects can subscribe to it without the publishing object knowing or caring. When an object fires off an event, if anyone happens to have subscribed to it then it calls each of their event handlers.

Callbacks are not published. Instead, a callback establishes a relationship between two classes where one object automatically reacts to another. A callback is generally kept private, and the class that stores the callback maintains control over who has access to it. A callback is often set up in an object's constructor.

Q: So a callback isn't an actual type in C#?

A: No, it isn't. A callback is a *pattern*—it's just a novel way of using the existing types, keywords and tools that C# comes with. Go back and take another look at the callback code you just wrote for the Bat and Ball. Did you see any new keywords that we haven't used before? Nope!

It turns out that there are a lot of patterns that you can use. In fact, there's a whole area of programming called *design patterns*. There are a lot of problems that you'll run into which have been solved before, and the ones that pop up over and over again have their own design patterns that you can benefit from.

↑
Check out "Head First Design Patterns" at the Head First Labs website. It's a great way to learn about different patterns that you can apply to your own programs.

www.headfirstlabs.com/books/hfdp/

Q: So callbacks are just private events?

A: Not quite. It seems easy to think about it that way, but private events are a different beast altogether. Remember what the `private` access modifier really means? When you mark a class member `private`, only instances of that same class can access it. So if you mark an event `private`, then other instances of the same class can subscribe to it. That's different from a callback, because it still involves one or more objects anonymously subscribing to an event.

Q: But it looks just like an event, except with the event keyword, right?

A: The reason a callback looks so much like an event is that they both use *delegates*. And it makes sense that they both use delegates, because that's C#'s tool for letting one object pass another object a reference to one of its methods.

But the big difference between normal events and callbacks is that an event is a way for a class to publish to the world that some specific thing has happened. A callback, on the other hand, is never published. It's private, and the method that's doing the calling keeps tight control over who it's calling.

←
The first one you'll learn about is called the "Observer" (or "Publisher-Subscriber") pattern, and it'll look really familiar to you. One object publishes information, and other objects subscribe to it. Hmm...

The Case of the Golden Crustacean

How did the other treasure hunters beat Henry to the crab?

The crux of the mystery lies in how the treasure hunter seeks his quarry. But first we'll need to see exactly what Henry found in the stolen diagrams.

In a stolen set of class diagrams, Henry discovers that the GoldenCrab class raises a RunForCover event every time anyone gets close to it. Even better, the event includes NewLocationArgs, which detail where the crab is moving to. But none of the other treasure hunters know about the event, so Henry figures he can cash in.



```
public class GoldenCrab {
    public delegate void Escape(NewLocationArgs e);
    public event Escape RunForCover;
    public void SomeonesNearby() {
        NewLocationArgs e = new NewLocationArgs("Under the rock");
        RunForCover(e);
    }
}

public class NewLocationArgs {
    public NewLocationArgs(HidingPlace newLocation) {
        this.newLocation = newLocation;
    }
    private HidingPlace newLocation;
    public HidingPlace NewLocation { get { return newLocation; } }
}
```

Any time someone comes close to the golden crab, its SomeonesNearby() method fires off a RunForCover event, and it finds a place to hide.

So how did Henry take advantage of his newfound insider information?

Henry adds code to his constructor to register his treasure_RunForCover() method as an event handler for the RunForCover event, on the crab reference he's got. Then, he sends a lowly underling after the crab, knowing it will run away, hide, and raise the RunForCover event—giving Henry's treasure_RunForCover() method all the information he needs.

```
public class TreasureHunter {
    public TreasureHunter(GoldenCrab treasure) {
        treasure.RunForCover += new GoldenCrab.Escape(treasure_RunForCover);
    }
    void treasure_RunForCover(NewLocationArgs e) {
        MoveHere(e.NewLocation);
    }
    void MoveHere(HidingPlace Location) {
        // ... code to move to a new location ...
    }
}
```

Henry thought he was being clever by altering his class's constructor to add an event handler that calls his MoveHere() method every time the crab raises its RunForCover event. But he forgot that the other treasure hunters inherit from the same class, and his clever code adds their event handlers to the chain, too!

And that explains why Henry's plan backfired. When he added the event handler to the TreasureHunter constructor, he was inadvertently **doing the same thing for all of the treasure hunters!** And that meant that every treasure hunter's event handler got chained onto the same RunForCover event. So when the Golden Crustacean ran for cover, everyone was notified about the event.. And all of that that would have been fine if Henry were the first one to get the message. But Henry had no way of knowing when the other treasure hunters would have been called—if they subscribed before he did, they'd get the event first.

Sharpen your pencil

```

public partial class Form1 : Form {
    Mole mole;
    Random random = new Random();
    public Form1() {
        InitializeComponent();

        mole = new Mole(random, new Mole._____ ( _____ ));
        timer1.Interval = random.Next(500, 1000);
        timer1.Start();
    }
    private void timer1_Tick(object sender, EventArgs e) {
        timer1.Stop();
        ToggleMole();
    }
    private void ToggleMole() {
        if (mole.Hidden == true)
            mole.Show();
        else
            mole.HideAgain();
        timer1.Interval = random.Next(500, 1000);
        timer1.Start();
    }
    private void MoleCallBack(int MoleNumber, bool Show) {
        if (MoleNumber < 0) {
            timer1.Stop();
            return;
        }
        Button button;
        switch (MoleNumber) {
            case 0: button = button1; break;
            case 1: button = button2; break;
            case 2: button = button3; break;
            case 3: button = button4; break;
            default: button = button5; break;
        }
        if (Show == true) {
            button.Text = "HIT ME!";
            button.BackColor = Color.Red;
        } else {
            button.Text = "";
            button.BackColor = SystemColors.Control;
        }
        timer1.Interval = random.Next(500, 1000);
        timer1.Start();
    }
    private void button1_Click(object sender, EventArgs e) {
        mole.Smacked(0);
    }
}

```

This method's if up or hide the mole when the timer's elapsed.

This switch makes sure that the right button changes its color and text.

When you double-click on the timer in the form (after you drag it out of the toolbox), the IDE will create this event handler for it. Timers fire the Tick event over and over again. You'll learn all about them in the next chapter.

The form passes a delegate pointing to a callback method into the mole's constructor. Fill it in.

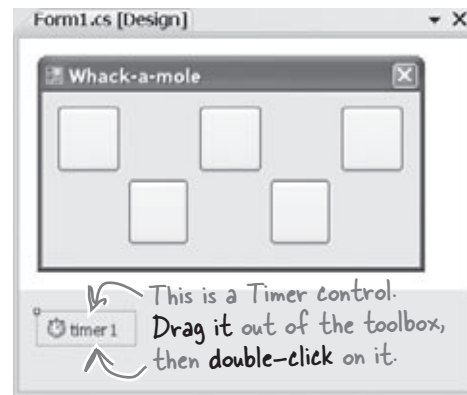

This is a Timer control. Drag it out of the toolbox, then double-click on it.

When you type in the code, add five button event handlers. Have button2_click() call mole.Smacked(1), and then make button3 call mole.Smacked(2), and make button4 call mole.Smacked(3) and button5 call mole.Smacked(4).

Just add these event handlers the usual way by double-clicking in the form designer.

```
public class Mole {
```

```
    public _____ void PopUp(int hole, bool show);
```

```
    private _____ popUpCallback;
    private bool hidden;
    public bool Hidden { get { return hidden; } }
    private int timesHit = 0;
    private int timesShown = 0;
    private int hole = 0;
    Random random;
```

Fill in the delegate and field to hold the delegate—they're both at the top of the Mole class.

Here's where we make sure the callback is not null—if it is, the Mole object throws an ArgumentException.

```
    public Mole(Random random, PopUp popUpCallback) {
        if (popUpCallback == null)
            throw new ArgumentException("popUpCallback can't be null");
        this.random = random;
```

```
        this._____ = _____;
        hidden = true;
    }
```

When the form creates a new Mole object, it passes it a reference to its callback method. Take a look in the form to see how the constructor is called, and then fill in this blank.

```
    public void Show() {
        timesShown++;
        hidden = false;
        hole = random.Next(5);
```

```
        _____(hole, true);
    }
```

After the mole shows itself, it needs to call the method on the form that displays the mole by turning the button red and showing the text "HIT ME!"

```
    public void HideAgain() {
        hidden = true;
```

```
        _____(hole, false);
        CheckForGameOver();
    }
```

The HideAgain() and Smacked() methods also use the callback delegate to call the method on the form.

```
    public void Smacked(int holeSmacked) {
        if (holeSmacked == hole) {
            timesHit++;
            hidden = true;
            CheckForGameOver();

            _____(hole, false);
        }
    }
```

The way the game works is that it uses the timer to wait a random period of time between half a second and 1.5 seconds. Once that time is elapsed, it tells the mole to show itself. The form gives the Mole object a callback that it uses to tell the form to show or hide the mole in one of the five holes. The form uses its timer to wait between .5 and 1.5 seconds again, and then tells the mole to hide itself.

```
    private void CheckForGameOver() {
        if (timesShown >= 10) {
            popUpCallback(-1, false);
            MessageBox.Show("You scored " + timesHit, "Game over");
            Application.Exit();
        }
    }
}
```

The game's over after the mole shows itself 10 times. Your score is the number of times you hit it.

Sharpen your pencil Solution

Fill in the blanks to make this game of Whack-a-mole work. You need to supply the code that does the callbacks. Once you've got it filled in, go ahead and type it into the IDE. It's fun!

```
public partial class Form1 : Form {
    private void Form1_Load(object sender, EventArgs e) {
        mole = new Mole(random, new Mole.PopUp (MoleCallback ));
        timer1.Interval = random.Next(500, 1000);
        timer1.Start();
    }
}
```

This is where the form passes a reference to its MoleCallback() method into the Mole object. That lets the mole call its method.

```
public class Mole {
    public delegate void PopUp(int hole, bool show);
    private PopUp popUpCallback;
    ...
}
```

Here's where the mole defines its delegate and uses it to set up a private field to hold a reference to the method on the form that changes the colors of the buttons.

```
public Mole(Random random, PopUp popUpCallback) {
    this.random = random;
    this.popUpCallback = popUpCallback ;
    hidden = true;
}
```

When the form creates a new instance of the Mole object, it passes a reference to its MoleCallback() method to the constructor as a parameter. This line in the constructor copies that reference to its popUpCallback field. Its methods can use that field to call the MoleCallback() method in the form.

```
public void Show() {
    timesShown++;
    hidden = false;
    hole = random.Next(5);
    popUpCallback (hole, true);
}
```

```
public void HideAgain() {
    hidden = true;
    popUpCallback (hole, false);
    CheckForGameOver();
}
```

When the mole shows itself, hides again, or gets smacked, the Mole object uses its popUpCallback delegate field to call the method on the form that changes the color and text of one of the buttons.

```
public void Smacked(int holeSmacked) {
    if (holeSmacked == hole) {
        timesHit++;
        hidden = true;
        CheckForGameOver();
        popUpCallback (hole, false);
    }
}
```

12 review and preview

* Knowledge, power, and building cool stuff

I just know I read about how upcasting and downcasting make event handling easier somewhere...

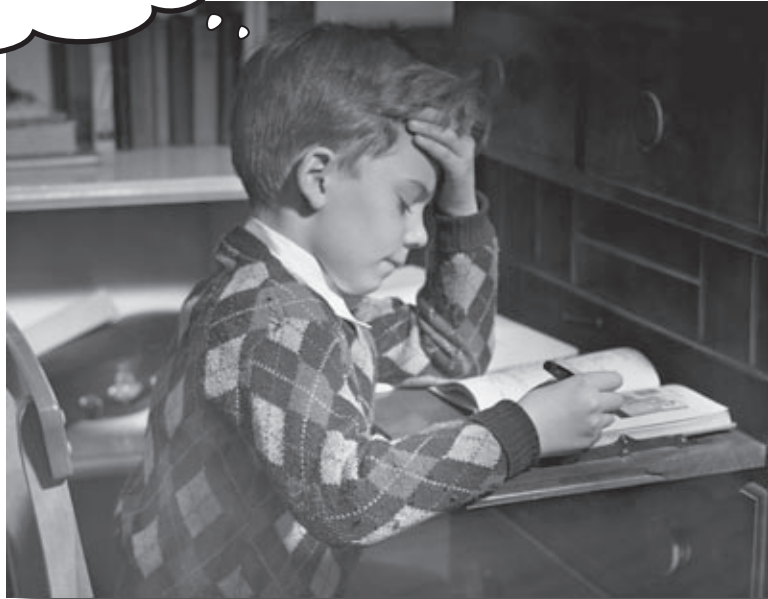

Learning's no good until you BUILD something.

Until you've actually written working code, it's hard to be sure if you really *get* some of the tougher concepts in C#. In this chapter, we're going to learn about some new odds and ends: **timers** and dealing with collections using **LINQ** (to name a couple). We're also going to build phase I of a **really complex application**, and make sure you've got a good handle on what you've already learned from earlier chapters. So buckle up...it's time to build some **cool software**.

You've come a long way, ~~baby~~

[note from human resources: "baby" is no longer politically correct. Please use age-challenged or infant to avoid offending readers.]

We've come a long way since we first used the IDE to help us rescue the Objectville Paper Company. Here's just a few of the things you've done over the last several hundreds pages:

You've built forms, used the .NET framework, and even talked with databases.

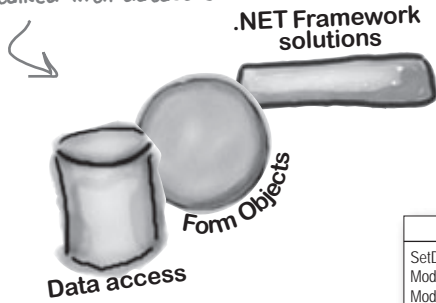

Objects, classes, instances... all these strange terms are now part of your everyday programming toolbox.

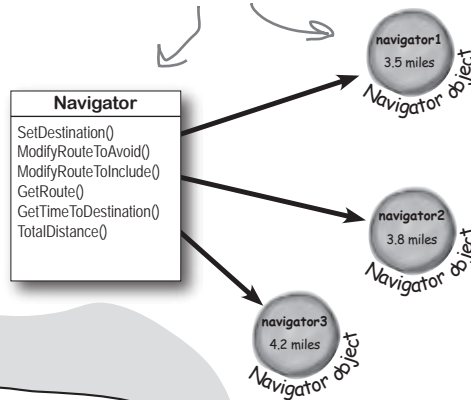

You've used inheritance, as well as interfaces and subclasses, to build object trees.

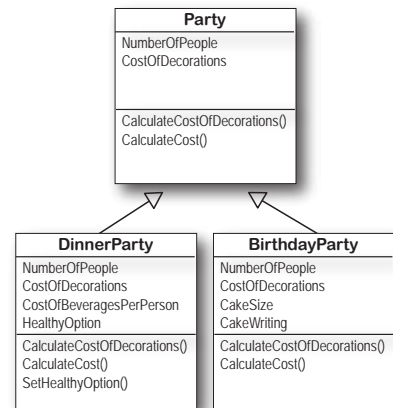

Even complex types like arrays are no big deal to work with.

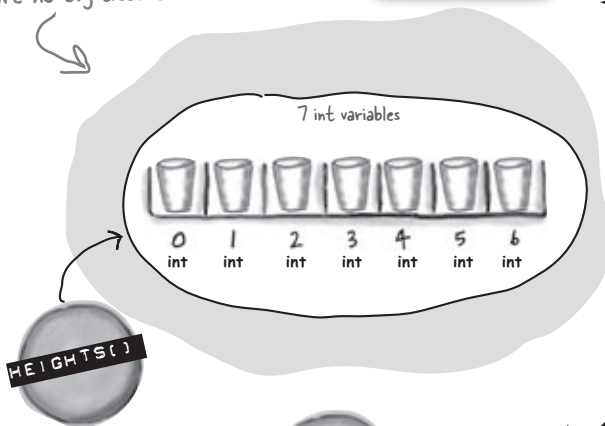

You've used events to notify objects about certain things that happen, while keeping your objects' concerns separate.

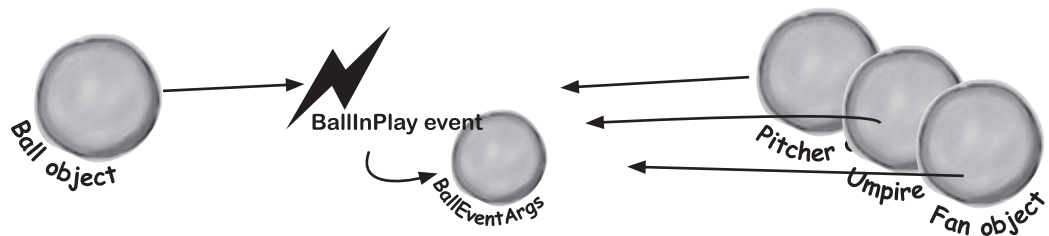

Debugging and exceptions are part of your problem-eliminating techniques.

```

private void RandomExcuseButton_Click(object sender, EventArgs e)
{
    if ([CheckBox1] == true) {
        CurrentExcuse = New Excuse(random, Folder);
        UpdateForm(false);
    }
}
    
```

We've also become beekeepers

Back in Chapter 6, we built some bee classes. Remember these?

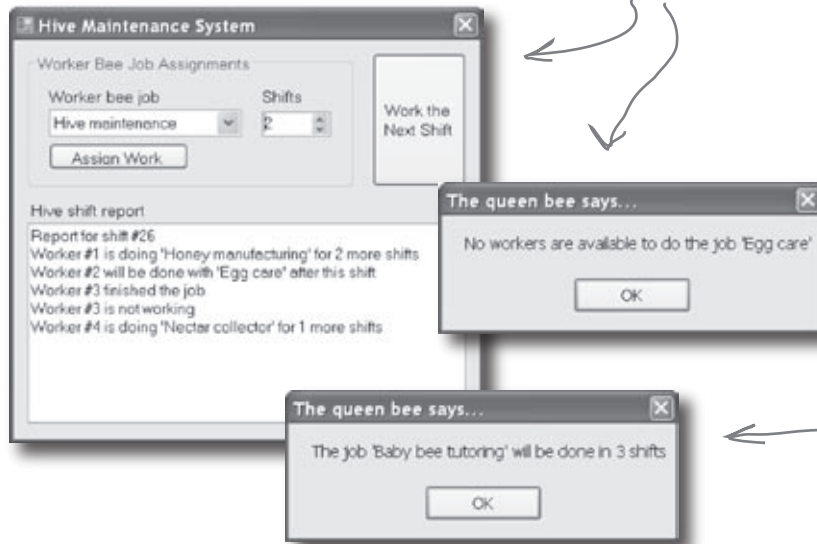

But we can do a lot better now...

You've learned a lot since Chapter 6, though. So let's start from scratch, and build an **animated beehive simulator** over the next few chapters. We'll end up with a user interface that shows us the hive and the field the bees are keeping, and even a stats window letting users know what their bees are doing.

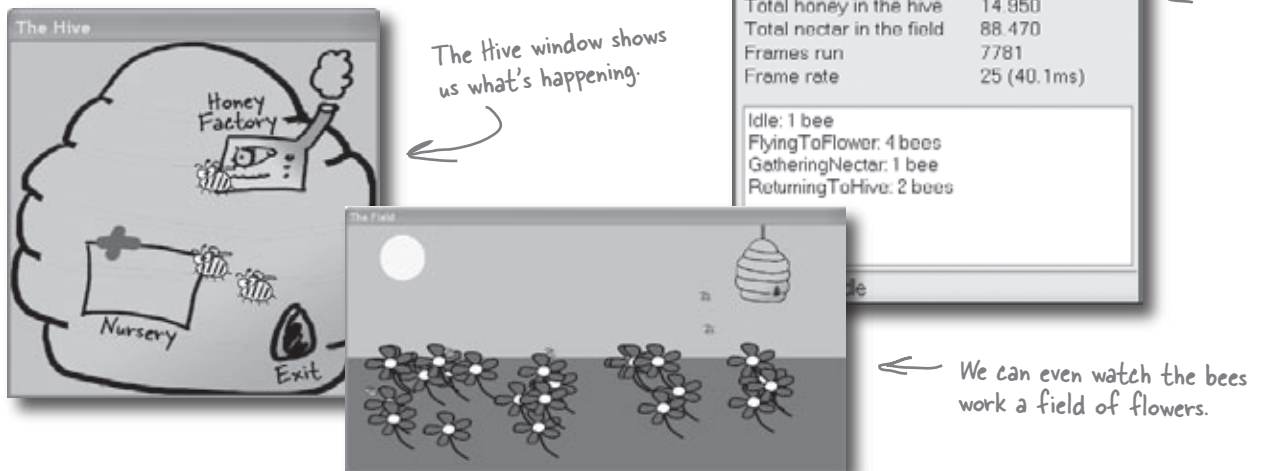

doesn't look too tough... right?

The beehive simulator architecture

Here's the architecture for the bee simulator. Even though the simulator will be controlling a lot of different bees, the overall object model is pretty simple.

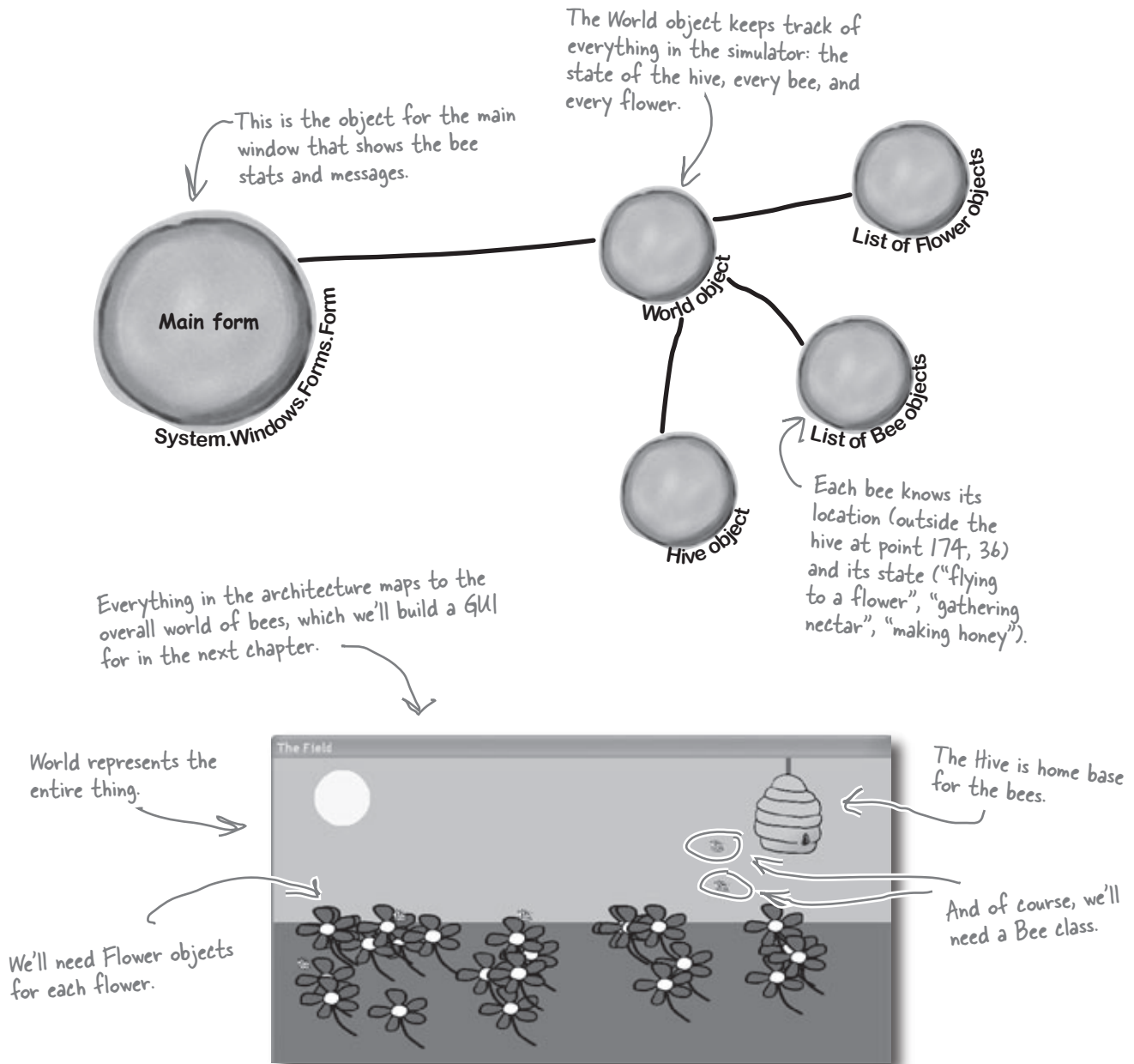

Building the beehive simulator

Of course, we've never built anything this complex before, so it's going to take us a couple of chapters to put all the pieces together. Along the way, you'll add timers, LINQ, and a lot of graphical skill to your toolkit.

Here's what you're going to do in this chapter (more to come in the next):

- 1** Build a Flower class that ages, produces nectar, and eventually wilts and dies.
- 2** Build a Bee class that has several different states (gathering nectar from a flower, returning to the Hive), and knows what to do based on its state.
- 3** Build a Hive class that has an entrance, exit, nursery for new bees, and honey factory for turning collected nectar into honey.
- 4** Build a World class that manages the hive, flowers, and bees for any given moment.
- 5** Build a main form that collects statistics from the other classes, and keeps the world going.



Exercise

Let's jump right into some code. First up, we need a Flower class. The Flower class has a location, defined by a Point, an age, and a lifespan. As time goes on, the flower gets older. Then, when its age reaches its lifespan, the flower dies. It's your job to put all this into action.

1 Write the skeleton code for Flower

Below is the class diagram for Flower. Write the basic class skeleton. Location, Age, Alive, Nectar, and NectarHarvested are **automatic properties**. NectarHarvested is writable, the other four are **read-only**. For now, leave the methods blank; we'll come back to those in a minute.

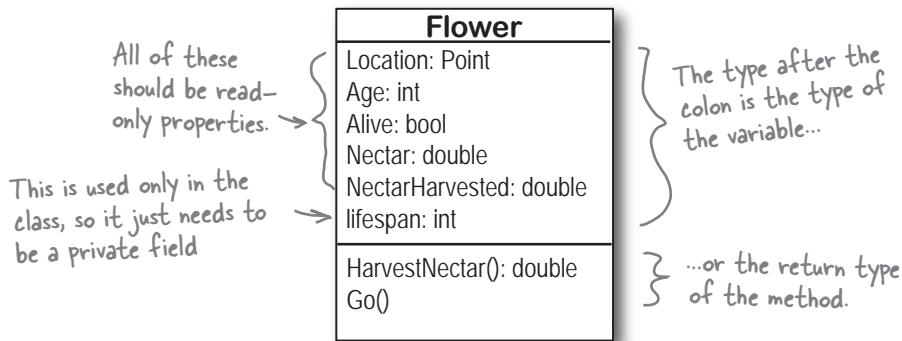

A class "skeleton" is just its field, property and method declarations, with no implementation.

2 Add several constants to the class

We need lots of constants for flowers. Add six to your Flower class:

- ◆ `LifeSpanMin`, the shortest flower lifespan
- ◆ `LifeSpanMax`, the longest flower lifespan
- ◆ `InitialNectar`, how much nectar a flower starts with
- ◆ `MaxNectar`, how much nectar a flower can hold
- ◆ `NectarAddedPerTurn`, how much nectar gets added each time the flower grows older
- ◆ `NectarGatheredPerTurn`, how much nectar gets collected during a cycle

FYI, you don't usually show constants in a class diagram.

You should be able to figure out the types for each constant based on their values. Flowers live between 15,000 and 30,000 cycles, and have 1.5 units of nectar when they start out. They can store up to 5 units of nectar. In each cycle of life, a flower adds 0.01 units of nectar, and in a single cycle, 0.3 units can be collected.

Since this simulator will be animated, we'll be drawing it frame by frame. We'll use the words "frame," "cycle," and "turn" interchangeably.

You'll need to add `using System.Drawing;` to the top of any class file that uses a `Point`.

3 Build the constructor

The constructor for `Flower` should take in a `Point`, indicating the flower's location, and an instance of the `Random` class. You should be able to use those arguments to set the location of the flower, and then set its age to 0, set the flower to alive, and set its nectar to the initial amount of nectar for a flower. Since no nectar has been harvested yet, set that variable correctly, as well. Finally, figure out the flower's lifespan. Here's a line of code to help you:

```
lifeSpan = random.Next(LifeSpanMin, LifeSpanMax + 1);
```

This will only work if you've got your variables and constants named right, as well as the argument to the `Flower` constructor.

4 Write code for the `HarvestNectar()` method

Every time this method is called, it should check to see if the nectar gathered every cycle is larger than the amount of nectar left. If so, return 0. Otherwise, you should remove the amount collected in a cycle from the nectar the flower has left, and return how much nectar was collected. Oh, and don't forget to add that amount to the `NectarHarvested` variable, which keeps up with the total nectar collected from this particular flower.

Hint: You'll use `NectarGatheredPerTurn`, `Nectar`, and `NectarHarvested` in this method, but nothing else.

5 Write code for the `Go()` method

This is the method that makes the flower go. Assume every time this method is called, one cycle passes, so update the flower's age appropriately. You'll also need to see if the age is greater than the flower's lifespan. If so, the flower dies.

Assuming the flower stays alive, you'll need to add the amount of nectar each flower gets in a cycle. Be sure and check against the maximum nectar your flower can store, and don't overrun that.

The final product will be **animated**, with little pictures of bees flying around. The `Go()` method will be called once every **frame**, and there will be several frames run per second.

Answers on the next page... try and finish your code and compile it before peeking.

where have all the flowers gone?



Exercise Solution

Your job was to build the Flower class for our beehive simulator.

```
public class Flower {
    private const int LifeSpanMin = 15000;
    private const int LifeSpanMax = 30000;
    private const double InitialNectar = 1.5;
    private const double MaxNectar = 5.0;
    private const double NectarAddedPerTurn = 0.01;
    private const double NectarGatheredPerTurn = 0.3;
    public Point Location { get; private set; }
    public int Age { get; private set; }
    public bool Alive { get; private set; }
    public double Nectar { get; private set; }
    public double NectarHarvested { get; set; }
    private int lifeSpan;

```

Location, Age, Alive, and Nectar are all read-only automatic properties.

Flowers have random lifespans so that the field of flowers doesn't all change exactly at once.

```
public Flower(Point location, Random random) {
    Location = location;
    Age = 0;
    Alive = true;
    Nectar = InitialNectar;
    NectarHarvested = 0;
    lifeSpan = random.Next(LifeSpanMin, LifeSpanMax + 1);
}

```

```
public double HarvestNectar() {
    if (NectarGatheredPerTurn > Nectar)
        return 0;
    else {
        Nectar -= NectarGatheredPerTurn;
        NectarHarvested += NectarGatheredPerTurn;
        return NectarGatheredPerTurn;
    }
}

```

As part of the simulator's animation, the Go() method will be called each frame. This makes the flower age just a tiny little bit per frame—as the simulator runs, those tiny bits will add up over time.

```
public void Go() {
    Age++;
    if (Age > lifeSpan)
        Alive = false;
    else {
        Nectar += NectarAddedPerTurn;
        if (Nectar > MaxNectar)
            Nectar = MaxNectar;
    }
}

```

Point lives in the System.Drawing namespace, so make sure you added using System.Drawing; to the top of the class file.

Flower
Location: Point
Age: int
Alive: bool
Nectar: double
NectarHarvested: double
lifespan: int
HarvestNectar(): double
Go()

NectarHarvested will need to be accessible to other classes.

A bee calls HarvestNectar() to get nectar out of a flower. A bee can only harvest a little bit of nectar at a time, so he'll have to sit near the flower for several turns until the nectar's all gone.

Make sure the flower stops adding nectar after it's dead.

Life and death of a flower

Our flower goes through a basic turn, living, adding nectar, having nectar harvested, and eventually dying:

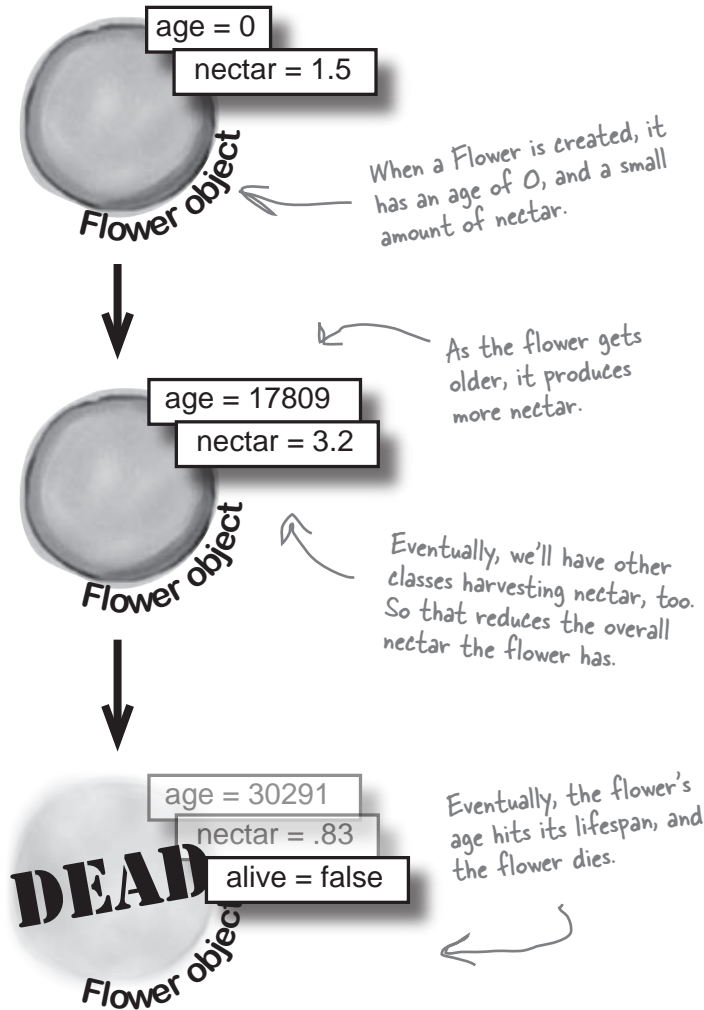

there are no Dumb Questions

Q: It doesn't look like NectarHarvested is used anywhere in the class, except where we increment it. What's that variable for?

A: Good catch! We're planning ahead a bit. Eventually, the simulator will keep an eye on flowers, and how much total nectar has been harvested, for our statistics monitor. So leave it in, and our other classes will use it shortly.

Q: Why all the read-only automatic properties?

A: Remember Chapter 5, and hiding our privates? Always a good practice. Flowers can take care of those values, so we've made them read-only. Other objects, like bees and the hive, should be able to read those properties, but not change them.

Q: My code looks different. Did I do something wrong?

A: You might have your code in each method in a different order, but as long as your code *functions* the same way as ours does, you'll be okay. That's another aspect of encapsulation: the internals of each class aren't important to other classes, as long as each class does what it's supposed to do.



If Go() increases the age of the Flower by 1, and the lifespan range is between 15,000 and 30,000, that means Go() will get called at least 15,000 times for each flower before it dies. How would you handle calling the method that many times? What if there are 10 flowers? 100? 1000?

Now we need a Bee class

With flowers ready to be harvested, we need a Bee class. Below is the basic code for Bee. The Bee knows its age, whether or not it's in the hive, and how much nectar it can collect. We've also added a method to move the bee towards a specific destination point.

```
public class Bee {
    private const double HoneyConsumed = 0.5;
    private const int MoveRate = 3;
    private const double MinimumFlowerNectar = 1.5;
    private const int CareerSpan = 1000;

    public int Age { get; private set; }
    public bool InsideHive { get; private set; }
    public double NectarCollected { get; private set; }

    private Point location;
    public Point Location { get { return location; } }
    private int ID;
    private Flower destinationFlower;
}
```

Like the Flower class, there are several bee-specific constants we need to define.

MinimumFlowerNectar is how the bee figures out which flowers are eligible for harvesting.

Each bee will be assigned its own unique ID number.

We used a backing field for location. If we'd used an automatic property, MoveTowardsLocation() wouldn't be able to set its members directly ("Location.X -= MoveRate").

```
public Bee(int id, Point location) {
    this.ID = id;
    Age = 0;
    this.location = location;
    InsideHive = true;
    destinationFlower = null;
    NectarCollected = 0;
}
```

A bee needs an ID and an initial location.

Bees start out inside the hive, they don't have a flower to go to, and they don't have any nectar.

```
public void Go(Random random) {
    Age++;
}
```

We'll have to add a lot more code to Go() before we're done, but this will get us started.

Here we used `Math.Abs()` to calculate the absolute value of the difference between the destination {and the current location.

```
private bool MoveTowardsLocation(Point destination)
{
    if (destination != null) {
        if (Math.Abs(destination.X - location.X) <= MoveRate &&
            Math.Abs(destination.Y - location.Y) <= MoveRate)
            return true;
        if (destination.X > location.X)
            location.X += MoveRate;
        else if (destination.X < location.X)
            location.X -= MoveRate;
        if (destination.Y > location.Y)
            location.Y += MoveRate;
        else if (destination.Y < location.Y)
            location.Y -= MoveRate;
    }
    return false;
}
```

If the bee has no destination, its field will be set to null. So we only move towards it if its destination is NOT null.

This method starts by figuring out if we're already within our `MoveRate` of being at the destination.

If we're not close enough, then we move towards the destination by our move rate.

The `MoveTowardsLocation()` destination moves the bee's current location by changing the X and Y values of its location field. It returns true if the bee's reached its destination.

We return false, since we're not yet at the destination point. We need to keep moving.



Exercise

Bees have lots of things they can do. Below is a list. Create a new enum that `Bee` uses called `BeeState`. You should also create a read-only automatic property called `CurrentState` for each `Bee` to track that bee's state. Set a bee's initial state to `idle`, and in the `Go()` method, add a switch statement that has an option for each item in the enum.

The enum item	What the item means
Idle	The bee isn't doing anything
FlyingToFlower	The bee's flying to a flower
GatheringNectar	The bee's gathering nectar from a flower
ReturningToHive	The bee's heading back to the hive
MakingHoney	The bee's making honey
Retired	The bee's hung up his wings



Exercise Solution

Bees have lots of things they can do. Below is a list. Create a new enum that `Bee` uses called `BeeState`. You should also create a private `currentState` field for each `Bee` to track that bee's state. Set a bee's initial state to `idle`, and in the `Go()` method, add a switch statement that has an option for each item in the enum.

```
public enum BeeState {
    Idle,
    FlyingToFlower,
    GatheringNectar,
    ReturningToHive,
    MakingHoney,
    Retired
}

public class Bee {
    // constant declarations
    // variable declarations

    public BeeState currentState { get; private set; }

    public Bee(int ID, Point InitialLocation) {
        this.ID = ID;
        Age = 0;
        location = InitialLocation;
        InsideHive = true;
        currentState = BeeState.Idle;
        destinationFlower = null;
        NectarCollected = 0;
    }
}
```

Here's the enum with all the different bee states.

We also need a variable to track the state of each bee.

The bee starts out idle.

Did you remember to add `using System.Drawing;` to the top of the class file (because it uses `Point`)?

```

public void Go(Random random) {
    Age++;
    switch (CurrentState) {
        case BeeState.Idle:
            if (Age > CareerSpan) {
                CurrentState = BeeState.Retired;
            } else {
                // What do we do if we're idle?
            }
            break;
        case BeeState.FlyingToFlower:
            // move towards the flower we're heading to
            break;
        case BeeState.GatheringNectar:
            double nectar = destinationFlower.HarvestNectar();
            if (nectar > 0)
                NectarCollected += nectar;
            else
                CurrentState = BeeState.ReturningToHive;
            break;
        case BeeState.ReturningToHive:
            if (!InsideHive) {
                // move towards the hive
            } else {
                // what do we do if we're inside the hive?
            }
            break;
        case BeeState.MakingHoney:
            if (NectarCollected < 0.5) {
                NectarCollected = 0;
                CurrentState = BeeState.Idle;
            } else {
                // once we have a Hive, we'll turn the nectar into honey
            }
            break;
        case BeeState.Retired:
            // Do nothing! We're retired!
            break;
    }
}

```

Here's the switch() statement to handle each bee's state.

We've filled out a few of the states. It's okay if you didn't come up with this code, but go ahead and add it in now.

If the age reaches the bee's lifespan, the bee retires. But he'll finish the current job before he does.

We'll fill this code in a bit later.

Here, we harvest nectar from the flower we're working...

...and if there's nectar left, add it to what we've already collected...

...but if there's no nectar left, head for the hive.

Returning to the hive is different based on whether we're already in the hive or not.

The bee adds half a unit of nectar to the honey factory at a time. If there's not enough nectar to add, the factory can't use it so the bee just discards it.

You should have each of these states covered.

P. A. H. B. (Programmers Against Homeless Bees)

We've got bees, and flowers full of nectar. We need to write code so the bees can collect nectar, but before that happens, where do the bees get created in the first place? And where do they take all that nectar? That's where a `Hive` class comes in.

The hive isn't just a place for bees to come back to, though. It has several locations within it, all with different points in the world. There's the entrance and the exit, as well as a nursery for birthing more bees and a honey factory for turning nectar into honey.

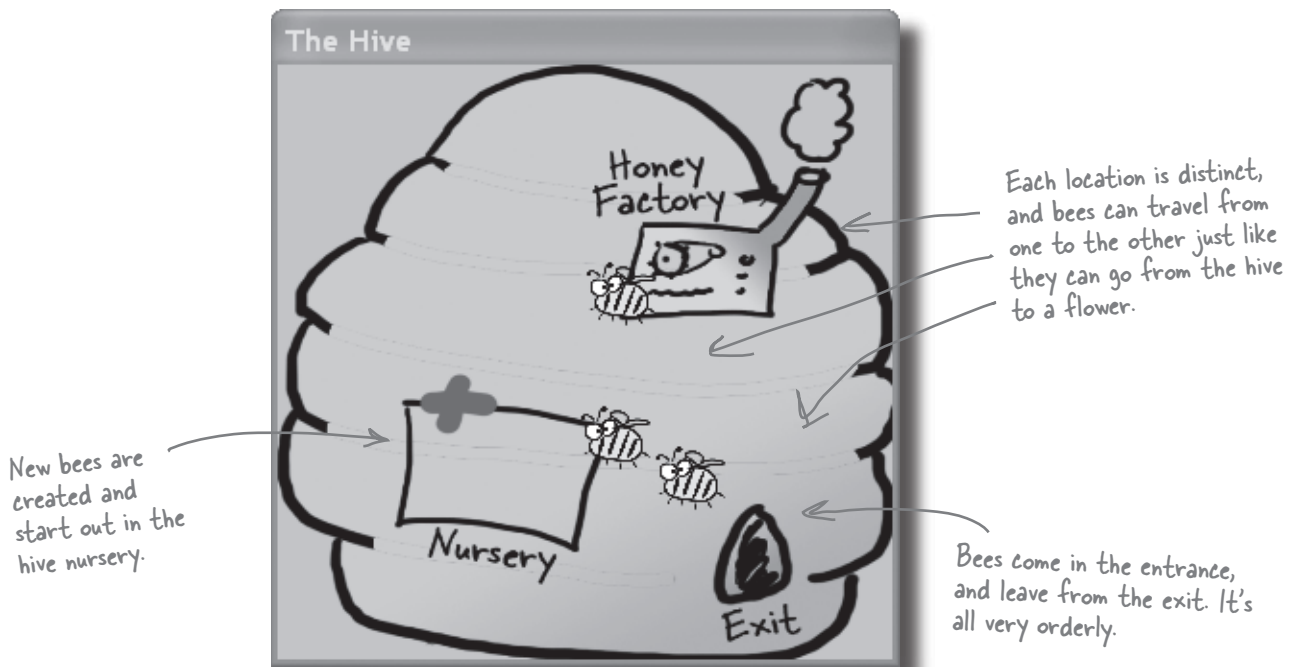

The hive runs on honey

The other big part that the hive plays is keeping up with how much honey it has stored up. It takes honey for the hive to keep running, and if new bees need to be created, that takes honey, too. On top of that, the honey factory has to take nectar that bees collect and turn that into honey. For every unit of nectar that comes in, .25 units of honey can be created.

Think about this for a second... as time passes, the hive uses honey to run, and to create more bees. Meanwhile, other bees are bringing in nectar, which gets turned into honey, which keeps things going longer. It's up to you (with some help) to model all of this in the simulator code.



Exercise

It's up to you to write the code for Hive.

1 Write the skeleton code for Hive

Like we did with the `Flower` class, you should start with a basic skeleton for `Hive`. The class diagram is shown to the right. Make the `Honey` a read-only automatic property, `locations` should be private, and `beeCount` is only used internally, so can be a private field.

Hive
Honey: double locations: Dictionary<string, Point> beeCount: int
InitializeLocations() AddHoney(Nectar: double): bool ConsumeHoney(amount: double): bool AddBee(random: Random) Go(random: Random) GetLocation(location: string): Point

2 Define the constants for the Hive

You need a constant for the initial number of bees (6), the amount of honey the hive starts with (3.2), the maximum amount of honey the hive can store (15), and ratio of units of nectar produced from units of honey (.25), the maximum number of bees (8), and the minimum honey required for the hive to birth new bees (4).

You'll have to figure out good names for each, as well as the types. For types, don't just think about initial values, but also the values these constants will be used with. Doubles pair best with other doubles, ints with other ints.

3 Write the code to work with Locations

First, write the `GetLocation()` method. It should take in a string, look up that string in the `locations` dictionary, and return the associated point. If it's not there, throw an `ArgumentException`.

Then, write the `InitializeLocations()` method. This method should set up the following locations in the hive:

- ◆ Entrance, at (600, 100)
- ◆ Nursery, at (95, 174)
- ◆ HoneyFactory, at (157, 98)
- ◆ Exit, at (194, 213)

Each of these maps to a location within the 2D space that our hive takes up. Later on, we'll have to make sure the simulator makes the hive cover all these points.

In this simulation, we're just assuming one hive, with fixed points. If you wanted multiple hives, you might make the points relative to the hive, instead of the overall world.

4 Build the Hive constructor

When a hive is constructed, it should set its honey to the initial amount of honey all hives have. It should setup the locations in the hive, and also create a new instance of `Random`. Then, `AddBee()` should be called—passing in the `Random` instance you just created—once for each bee that starts out in the hive.

`AddBee()` needs a `Random` object because it adds a random value to the Nursery location—that way the bees don't start on top of each other.



Exercise Solution

Your job was to start building the Hive class.

Make sure you add "using System.Drawing;" because this code uses Point.

```
public class Hive {
    private const int InitialBees = 6;
    private const double InitialHoney = 3.2;
    private const double MaximumHoney = 15.0;
    private const double NectarHoneyRatio = .25;
    private const double MinimumHoneyForCreatingBees = 4.0;
    private const int MaximumBees = 8;

    private Dictionary<string, Point> locations;
    private int beeCount = 0;

    public double Honey { get; private set; }

    private void InitializeLocations() {
        locations = new Dictionary<string, Point>();
        locations.Add("Entrance", new Point(600, 100));
        locations.Add("Nursery", new Point(95, 174));
        locations.Add("HoneyFactory", new Point(157, 98));
        locations.Add("Exit", new Point(194, 213));
    }

    public Point GetLocation(string location) {
        if (locations.Keys.Contains(location))
            return locations[location];
        else
            throw new ArgumentException("Unknown location:" + location);
    }

    public Hive() {
        Honey = InitialHoney;
        InitializeLocations();
        Random random = new Random();
        for (int i = 0; i < InitialBees; i++)
            AddBee(random);
    }

    public bool AddHoney(double nectar) { return true; }
    public bool ConsumeHoney(double amount) { return true; }
    private void AddBee(Random random) { }
    public void Go(Random random) { }
}
```

You might have different names for your constants. That's okay, as long as you're consistent in the rest of your code.

We made MaximumHoney a double, since it can range from InitialHoney (3.2) to this value. Since InitialHoney will need to be a double, it's best to make this a double, too.

Remember dictionaries? Ours stores a location, keyed with a string value.

Don't forget to create a new instance of Dictionary, or this won't work.

The rest of this method is pretty straightforward.

This method protects other classes from working with our locations dictionary and changing something they shouldn't. It's an example of encapsulation.

You should have called AddBee() once for each bee that a hive starts with.

We don't have code for these yet, but you should have built empty methods as placeholders.

You could also throw a NotImplementedException in any method you haven't implemented yet. That's a great way to keep track of code you still have to build.



Isn't this sort of a weird way to build code? Our bees don't know about flowers yet, and our hive is full of empty method declarations. Nothing actually works yet, right?

Real code is built bit by bit

It would be nice if you could write all the code for a single class at one time, compile it, test it, and put it away, and **then** start on your next class. Unfortunately, that's almost never possible.

More often than not, you'll write code just the way we are in this chapter: piece by piece. We were able to build pretty much the entire `Flower` class, but when it came to `Bee`, we've still got some work to do (mostly telling it what to do for each state).

And now, with `Hive`, we've got lots of empty methods to fill in. Plus, we haven't hooked any `Bees` up to the `Hive`. And there's still that nagging problem about how to call the `Go()` method in all these objects thousands of times...



But we didn't **really** start out by putting the classes together! We figured out the architecture first, and **then** started building.

First you design, then you build

We started out the project knowing exactly what we wanted to build: a beehive simulator. And we know a lot about how the bees, flowers, hive, and world all worked together. That's why we started out with the **architecture**, which told us how the classes would work with each other. Then we could move onto each class, designing them individually.

Projects always go a lot more smoothly if you have a good idea of what you're building **before** you start building it. That seems pretty straightforward and common-sense. But it makes all the difference in the final product.

Filling out the Hive class

Let's get back to the Hive class, and fill in a few of those missing methods:

```

public class Hive {
    // constant declarations
    // variable declarations

    // InitializeLocations()
    // GetLocation()
    // Hive constructor

    public bool AddHoney(double nectar) {
        double honeyToAdd = nectar * NectarHoneyRatio;
        if (honeyToAdd + Honey > MaximumHoney)
            return false;
        Honey += honeyToAdd;
        return true;
    }

    public bool ConsumeHoney(double amount) {
        if (amount > Honey)
            return false;
        else {
            Honey -= amount;
            return true;
        }
    }

    private void AddBee(Random random) {
        beeCount++;
        int r1 = random.Next(100) - 50;
        int r2 = random.Next(100) - 50;
        Point startPoint = new Point(locations["Nursery"].X + r1,
                                     locations["Nursery"].Y + r2);
        Bee newBee = new Bee(beeCount, startPoint);
        // Once we have a system, we need to add this bee to the system
    }

    public void Go(Random random) { }
}

```

First, we figure out how much honey this nectar can be converted to...

...and then see if there's room in the hive for that much more honey.

If there's room, we add the honey to the hive.

This method takes an amount of honey, and tries to consume it from the hive's stores.

If there's not enough honey in the hive to meet the demand, we return false.

If there's enough, remove it from the hive's stores and return true.

This creates a point within 50 units in both the X and Y direction from the nursery location.

Add a new bee, at the designated location.

We'll finish AddBee() and fill in the Go() method soon...

This is private... only Hive instances can create bees.

The hive's Go() method

We've already written a Go() method for Flower, and a Go() method for Bee (even though we've got some additional code to add in). Here's the Go() method for Hive:

```
public void Go(Random random) {
    if (Honey > MinimumHoneyForCreatingBees)
        AddBee(random);
}
```

The only constraint (at least for now) is the hive must have enough honey to create more bees.

The same instance of Random that got passed to Go() gets sent to the AddBee() method.

Unfortunately, this isn't very realistic. Lots of times in a busy hive, the queen doesn't have time to create more bees. We don't have a QueenBee class, but let's assume that when there's enough honey to create bees, a new bee actually gets created 10% of the time. We can model that like this:

```
public void Go(Random random) {
    if (Honey > MinimumHoneyForCreatingBees
        && random.Next(10) == 1) {
        AddBee(random);
    }
}
```

This is an easy way to simulate a 1 in 10 chance of a bee getting created. It comes up with a random number between 0 and 9. If the number is 1, then create the bee.

One reason to leave it out is so that you can save the Random seed—that way you can re-run a specific simulation... if you feel like doing that later!

there are no Dumb Questions

Q: So the hive can create an infinite number of bees?

A: Right now it can—or, at least, it's got a very large limit—but you're right, that's not very realistic. Later on, we'll come back to this, and add a constraint that only lets so many bees exist in our simulator world at one time.

Q: Couldn't we assign that instance of Random to a property of the class, instead of passing it on to AddBee()?

A: You sure could. Then AddBee could use that property, rather than a parameter passed in. There's not really a right answer to this one; it's up to you.

Q: I still don't understand how all of these Go() methods are getting called.

A: That's okay, we're just about to get to that. First, though, we need one more object: the World class, which will keep track of everything that's going on in the hive, track all the bees, and even keep up with flowers.

We're ready for the World

With a Hive, Bee, and Flower class in place, we can finally build the World class. World handles coordination between all the individual pieces of our simulator: keeping up with all the bees, telling the hive if there is room for more bees, locating flowers, etc.:

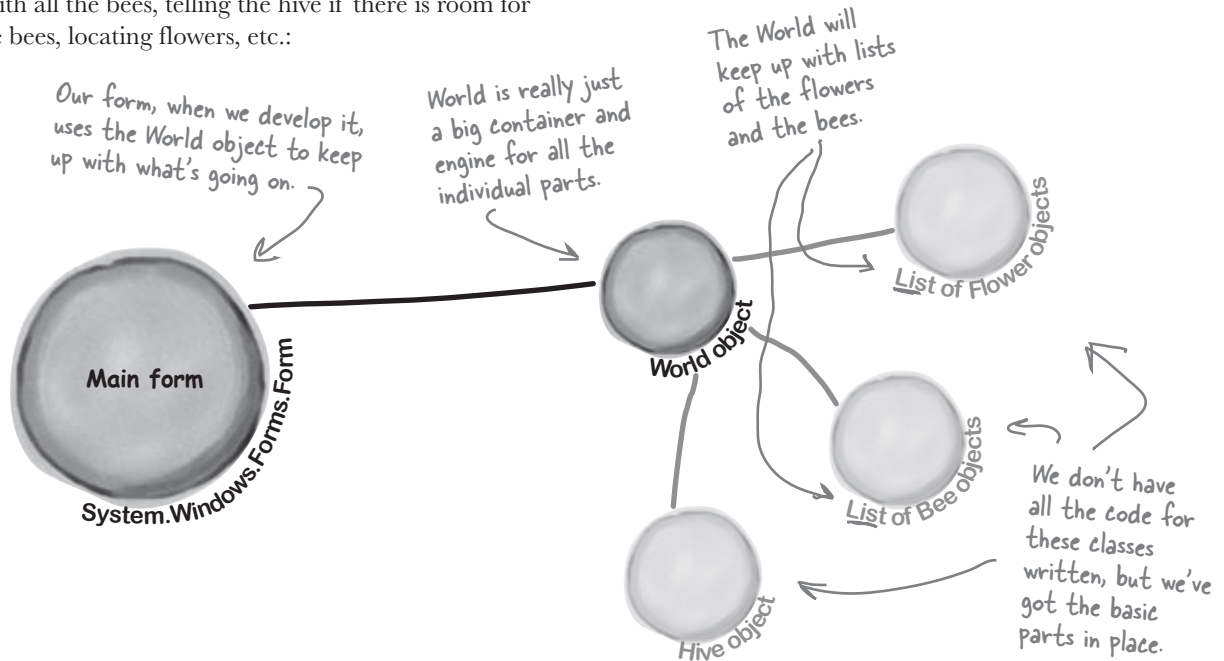

The World object keeps everything Go () ing

One of the biggest tasks of the World object is, for each turn in the simulator, to call Go () on every Flower, Bee, and Hive instance. In other words, World makes sure that life continues in the simulator world.

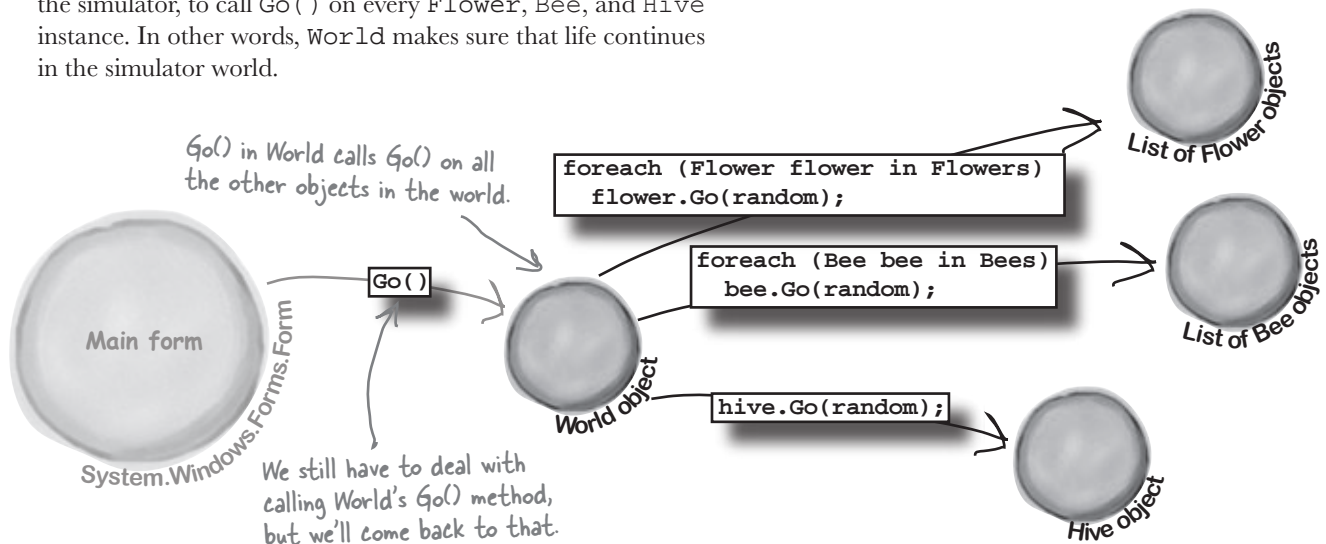

We're building a turn-based system

Our `Go()` methods in each object are supposed to run each **turn**, or **cycle**, of our simulator. A turn in this case just means an arbitrary amount of time... for instance, a turn could be every 10 seconds, or every 60 seconds, or every 10 minutes.

The main thing is that a turn affects every object in the world. The hive ages by one "turn", checking to see if it needs to add more bees. Then each bee takes a turn, moving a very small distance towards its destination or doing one small action, and getting older. Then each flower takes a turn, manufacturing a little nectar and getting older too. And that's what `World` does: it makes sure that every time its `Go()` method is called, every object in the world gets a turn to act.

Each "turn" will be drawn as a single frame of animation, so the world only needs to change a tiny little bit each turn.

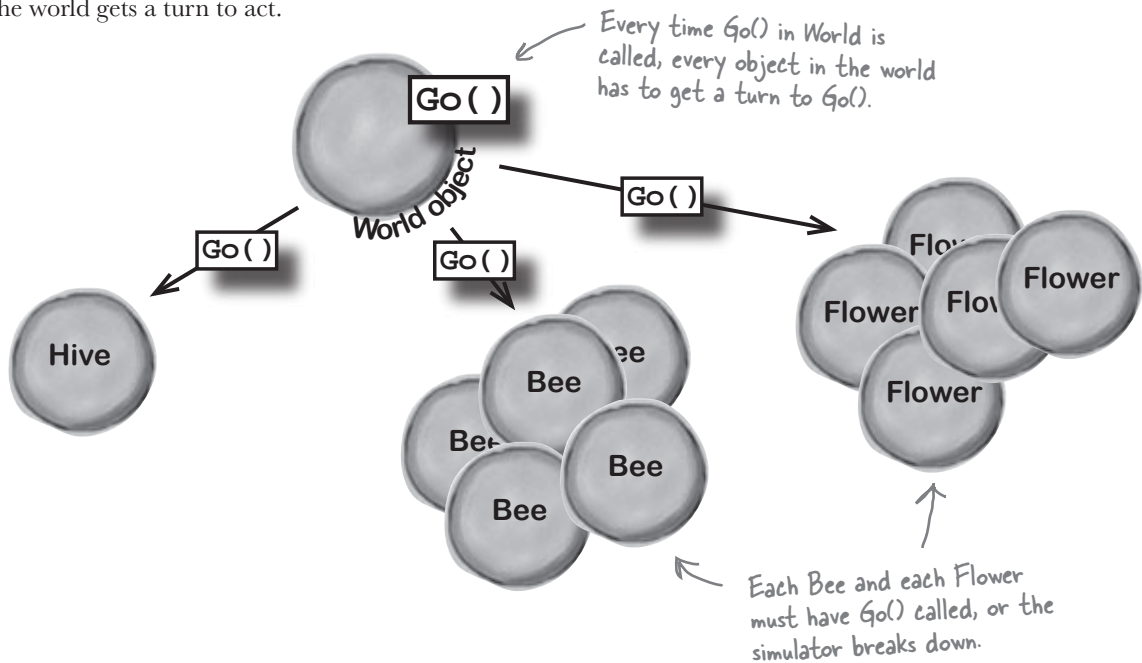

Sharpen your pencil

One of the big object-oriented principles we've been using in the simulator is encapsulation (flip back to Chapter 5 for a refresher). See if you can look over the code we've developed so far and come up with two examples of encapsulation for each class you've built.

Hive

1.
2.

Bee

1.
2.

Flower

1.
2.

Here's the code for World

The World class is actually one of the simpler classes in our simulator. Here's a starting point for the code. But if you look closely, you'll notice that it's missing a few things (which you'll add in just a minute).

```
using System.Drawing;
public class World {
    private const double NectarHarvestedPerNewFlower = 50.0;
    private const int FieldMinX = 15;
    private const int FieldMinY = 177;
    private const int FieldMaxX = 690;
    private const int FieldMaxY = 290;

    public Hive Hive;
    public List<Bee> Bees;
    public List<Flower> Flowers;

    public World() {
        Bees = new List<Bee>();
        Flowers = new List<Flower>();
        Random random = new Random();
        for (int i = 0; i < 10; i++)
            AddFlower(random);
    }

    public void Go(Random random) {
        Hive.Go(random);

        for (int i = Bees.Count - 1; i >= 0; i--) {
            Bee bee = Bees[i];
            bee.Go(random);
            if (bee.CurrentState == BeeState.Retired)
                Bees.Remove(bee);
        }

        double totalNectarHarvested = 0;
        for (int i = Flowers.Count - 1; i >= 0; i--) {
            Flower flower = Flowers[i];
            flower.Go();
            totalNectarHarvested += flower.NectarHarvested;
            if (!flower.Alive)
                Flowers.Remove(flower);
        }
    }
}
```

These define the bounds of the field, which is where flowers can live.

Every world has one hive, a list of bees, and a list of flowers.

When we create a new world, we initialize our lists, create a new hive, and then add 10 initial flowers.

This is easy... we just tell the Hive to Go(), passing in a Random instance.

We run through all the current bees and tell them Go().

If a bee's retired, we need to take it out of the world.

We run through each flower and tell it to Go().

We need to keep up with how much nectar's been collected this turn, too. So we get that by summing up the nectar collected from each flower.

Just like bees, we remove any flowers that die during this turn.

Sharpen your pencil Solution

Here are the ones we came up with. Did you come up with any others?

Hive

1. The hive's Locations dictionary is private
2. It gives the bees a method to add honey

Bee

1. The bee's location is read-only
2. So is its age. So other classes can't write to them

Flower

1. The flower provides a method to gather nectar
2. And it keeps its alive boolean private

```

if (totalNectarHarvested > NectarHarvestedPerNewFlower) {
    foreach (Flower flower in Flowers)
        flower.NectarHarvested = 0;
    AddFlower(random);
}
}

private void AddFlower(Random random)
{
    Point location = new Point(random.Next(FieldMinX, FieldMaxX),
                                random.Next(FieldMinY, FieldMaxY));
    Flower newFlower = new Flower(location, random);
    Flowers.Add(newFlower);
}
}

```

Bees pollinate flowers as they harvest nectar. Once they've harvested enough nectar from the flowers, they've pollinated enough for the world to add a new flower.

If there's enough nectar in the field, true, the world adds a new flower.

This handles coming up with a random location in the field...

...and then adding a new flower in that location.

there are no Dumb Questions

Q: Why don't you use foreach loops to remove dead flowers and retired bees?

A: Because you can't remove items from a collection from inside a foreach loop that's iterating on it. If you do, .NET will throw an exception.

Q: Okay, then why does each of those for loops start at the end of the list and count down to 0?

A: Because each loop needs to preserve the numbering of the list. Let's say you started at the beginning of a list of five flowers, and your loop discovered that one of the flowers in the middle was dead. If it removes

the flower at index #3, now the list only has 4 flowers in it, and there's a new flower at index #3—and that flower will end up getting skipped, because the next time through the loop it'll look at index #4.

If the loop starts at the end, then the flower that moves into the empty slot will already have been looked at by the loop, so there's no chance of missing a flower.



Exercise

With all four of our core classes in place, we've got some work to do to tie them all together. Follow the steps below, and you should have working Bee, Hive, Flower, and World classes. But beware: you'll have to make changes to almost every class, in several places, before you're done.

- 1 Update Bee to take in a Hive and World reference.**
 Now that we've got a class for `Hive` and a class for `World`, `Bee` objects need to know about both. Update your code to take in references to a bee's hive and world as parameters to its constructor and save those references for later use.
- 2 Update Hive to take in a World reference.**
 Just as a `Bee` needs to know about its `Hive`, a `Hive` needs to know about its `World`. Update `Hive` to take in a `World` reference in its constructor, and save that reference. You should also update the code in `Hive` that creates new bees to pass into the `Bee` a reference to itself (the `Hive`), and the `World`.
- 3 Update World to pass itself into a new Hive.**
 Update your `World` class so that when it creates a new `Hive`, it passes in a reference to itself.



STOP! At this point, you should be able to compile all of your code. If you can't, check through it and correct any mistakes before continuing on.

- 4 Place an upper limit on the bees that Hive can create.**
 The `Hive` class has a `MaximumBees` constant that determines how many bees the `Hive` can support (inside and outside the hive, combined). Now that the `Hive` has access to the `World`, you should be able to enforce that constraint.
- 5 When the Hive creates bees, let the World know.**
 The `World` class uses a `List` of bee objects to keep up with all the bees that exist. When the `Hive` creates a new `Bee`, make sure that `Bee` gets added to the overall list that the `World` is keeping up with.

Hint: Look at code near where you create or add bees. There are two places where code related to this occurs in `Hive`, so be careful.

there are no Dumb Questions

Q: Why did you throw an exception in the `Hive` class's `GetLocation()` method?

A: Because we needed a way to deal with bad data passed into the parameter. The hive has a few locations, but the parameter to `GetLocations()` can pass any string. What happens if there's a bug in the program that causes an invalid string (like an empty string, or the name of a location that's not in the locations dictionary) to be sent as the parameter? What should the method return?

When you've got an invalid parameter and it's not clear what to do with it, it's always a good idea to throw a new `ArgumentException`. Here's how the `GetLocation()` method does it:

```
throw new ArgumentException(
    "Unknown location: " + location);
```

This statement causes the `Hive` class to throw an `ArgumentException` with the message "Unknown location:" that contains the location that it couldn't find.

The reason this is useful is that it immediately alerts you if a bad location parameter is passed to the method. And by including the parameter in the exception message, you're giving yourself a some valuable information that will help you debug the problem.

Q: What's the point of storing all the locations in a `Point` if we're not drawing anything?

A: Every bee has a location, whether or not you draw it on the screen in that location. The job of the `Bee` object is to keep track of where it is in the world. Each time its `Go()` method is called, it needs to move a very small distance towards its destination.

Now, even though we may not be drawing a picture of the bee yet, the bee still needs to keep track of where it is inside the hive or in the field, because it needs to know if it's arrived at its destination.

Q: Then why use `Point` to store the location, and not something else? Aren't `Points` specifically for drawing?

A: Yes, a `Point` is what all of the visual controls use for their `Location` properties. Plus, it'll come in handy when we do the animation. However, just because .NET uses them that way, that doesn't mean it's not also useful for us to keep track of locations. Yes, we could have created our own `BeeLocation` class with integer fields called `X` and `Y`. No reason reinvent the wheel when C# and .NET give us `Point` for free!

It's almost always easier to repurpose or extend an existing class that does **MOSTLY what you want it to do, rather than creating an all new class from scratch.**



Exercise Solution

With all four of our core classes in place, we've got some work to do to tie them all together. Follow the steps below, and you should have working Bee, Hive, Flower, and World classes. Here's how we made the changes to put this into place.

1 Update Bee to take in a Hive and World reference.

Now that we've got a class for `Hive` and a class for `World`, `Bee` objects need to know about both. Update your code to take in references to a bee's hive and world in the constructor and save those references for later use.

```
public class Bee {
    // existing constant declarations
    // existing variable declarations
    private World world;
    private Hive hive;

    public Bee(int ID, Point InitialLocation, World world, Hive hive) {
        // existing code
        this.world = world;
        this.hive = hive;
    }
}
```

This is pretty straightforward...take these in, assign them to private fields.

2 Update Hive to take in a World reference.

Just as a `Bee` needs to know about its `Hive`, a `Hive` needs to know about its `World`. Update `Hive` to take in a `World` reference in its constructor, and save that reference. You should also update the code in `Hive` that creates new bees to pass into the `Bee` a reference to itself (the `Hive`), and the `World`.

```
public class Hive {
    private World world;

    public Hive(World world) {
        this.world = world;
        // existing code
    }

    public void AddBee(Random random) {
        // other bee creation code
        Bee newBee = new Bee(beeCount, startPoint, world, this);
    }
}
```

More basic code... get the reference, set a private field. You want to assign the world FIRST because the rest of the constructor needs to use it.

New bees need a reference to the world, and to the hive, now.

If you're having trouble getting this running, you can download the code for this exercise (and all the others, too) from:

<http://www.headfirstlabs.com/books/hfcsharp/>

3 Update World to pass itself into a new Hive.

Update your `World` class so that when it creates a new `Hive`, it passes in a reference to itself.

```
public World() {
    Bees = new List<Bee>();
    Flowers = new List<Flower>();
    Hive = new Hive(this);
    Random random = new Random();
    for (int i = 0; i < 10; i++)
        AddFlower(random);
}
```

this passes in the reference to the Hive.

4 Place an upper limit on the bees that Hive can create.

The `Hive` class has a `MaximumBees` constant that determines how many bees the `Hive` can support (inside and outside the hive, combined). Now that the `Hive` has access to the `World`, you should be able to enforce that constraint.

```
public void Go(Random random) {
    if (world.Bees.Count < MaximumBees
        && Honey > MinimumHoneyForCreatingBees
        && random.Next(10) == 1) {
        AddBee(random);
    }
}
```

We can use the `World` object to see how many total bees there are, and compare that to the maximum bees for this hive.

We put that comparison first. If there's no room for bees, no sense in seeing if there's enough honey to create bees.

5 When the Hive creates bees, let the World know.

The `World` class keeps up with all the bees that exist. When the `Hive` creates a new `Bee`, make sure that `Bee` gets added to the overall list that the `World` is keeping up with.

```
private void AddBee(Random random) {
    beeCount++;
    // Calculate the starting point
    Point startPoint = // start the near the nursery
    Bee newBee = new Bee(beeCount, startPoint, world, this);
    world.Bees.Add(newBee);
}
```

We add the new bee to the world's overall bee list.

This demonstrates one of the reasons we need a world reference in the `Hive` class.

Giving the bees behavior

The one big piece of code that's missing in our current classes is the Bee's Go() method. We were able to code a few of the states earlier, but there are plenty left (Idle is incomplete, FlyingToFlower, and part of MakingHoney).

Let's finish up those remaining states now:

```

public void Go(Random random) {
    Age++;
    switch (CurrentState) {
        case BeeState.Idle:
            if (Age > CareerSpan)
                CurrentState = BeeState.Retired;
            else if (world.Flowers.Count > 0
                && hive.ConsumeHoney(HoneyConsumed)) {
                Flower flower =
                    world.Flowers[random.Next(world.Flowers.Count)];
                if (flower.Nectar >= MinimumFlowerNectar && flower.Alive) {
                    destinationFlower = flower;
                    CurrentState = BeeState.FlyingToFlower;
                }
            }
            break;
        case BeeState.FlyingToFlower:
            if (!world.Flowers.Contains(destinationFlower))
                CurrentState = BeeState.ReturningToHive;
            else if (InsideHive) {
                if (MoveTowardsLocation(hive.GetLocation("Exit"))) {
                    InsideHive = false;
                    location = hive.GetLocation("Entrance");
                }
            }
            else
                if (MoveTowardsLocation(destinationFlower.Location))
                    CurrentState = BeeState.GatheringNectar;
            break;
        case BeeState.GatheringNectar:
            double nectar = destinationFlower.HarvestNectar();
            if (nectar > 0)
                NectarCollected += nectar;
            else
                CurrentState = BeeState.ReturningToHive;
            break;
    }
}

```

If we're idle, we want to go find another flower to harvest from.

See if there are flowers left, and then consume enough honey to keep on going. Otherwise, we're stuck.

We need another living flower with nectar.

Assuming that all works out, go to the new flower.

Make sure the flower hasn't died as we're heading toward it.

That's why we passed a reference to the hive to the Bee constructor.

If we can get to the exit, then we're out of the hive. Update our location. Since we're now on the field form, we should fly out near the entrance.

If we're out of the hive, and the flower is alive, get to it and start gathering nectar.

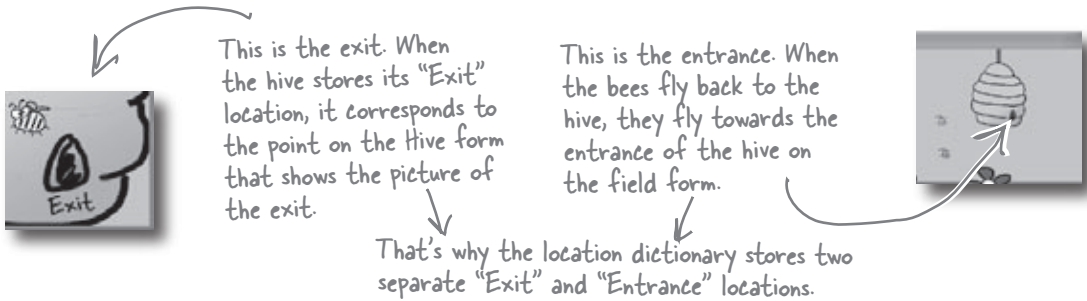

```

case BeeState.ReturningToHive:
    if (!InsideHive) {
        if (MoveTowardsLocation(hive.GetLocation("Entrance"))) {
            InsideHive = true;
            location = hive.GetLocation("Exit");
        }
    }
    else
        if (MoveTowardsLocation(hive.GetLocation("HoneyFactory")))
            CurrentState = BeeState.MakingHoney;
    break;
case BeeState.MakingHoney:
    if (NectarCollected < 0.5) {
        NectarCollected = 0;
        CurrentState = BeeState.Idle;
    }
    else
        if (hive.AddHoney(0.5))
            NectarCollected -= 0.5;
        else
            NectarCollected = 0;
    break;
case BeeState.Retired:
    // Do nothing! We're retired!
    break;
}
}

```

If we've made it to the hive, update our location and the insideHive status.

If we're already in the hive, head to the honey factory.

Try and give this nectar to the hive.

If the hive could use the nectar to make honey...
...remove it from the bee.

If the hive's full, AddHoney() will return false, so the bee just dumps the rest of the nectar so he can fly out on another mission.

Once the bee's retired, he just has to wait around until the Hive removes him from the list. Then he's off to Miami!

BRAIN POWER

Suppose you wanted to change the simulator so it took two turns to reach a flower, and two turns to go from a flower back to the hive. Without writing any code, which **methods** of which classes would you have to change to put this new behavior into place?

The main form tells the world to Go()

Okay, so you know that the world advances by one frame every turn its `Go()` method is called. But what calls that `Go()` method? Why, the main form, of course! Time to lay it out.

Go ahead and add a new form to your project. Make it look like the form below. We're using some new controls, but we'll explain them all over the next several pages.

The labels in the right-hand column will show the stats. Name them "Bees", "Flowers", "HoneyInHive", etc.

The ToolStrip control puts a toolbar at the top of your form. You can add the two buttons using the dropdown that appears on the ToolStrip when you're in the form designer. Set each button's `DisplayStyle` to `Text`.

Each of these labels lives in one cell of a `TableLayoutPanel` control. You lay it out just like a table in Microsoft Word. Click on the little black arrow to add, remove, and resize columns and rows.

Add a `StatusStrip` to put a status bar on the bottom. Use the dropdown that appears on the `StatusStrip` in the designer to add a `StatusLabel` to it.

Add a `Timer` control to the form. It doesn't show up at all—it's a non-visual component that the form designer displays as an icon in the space below the form.

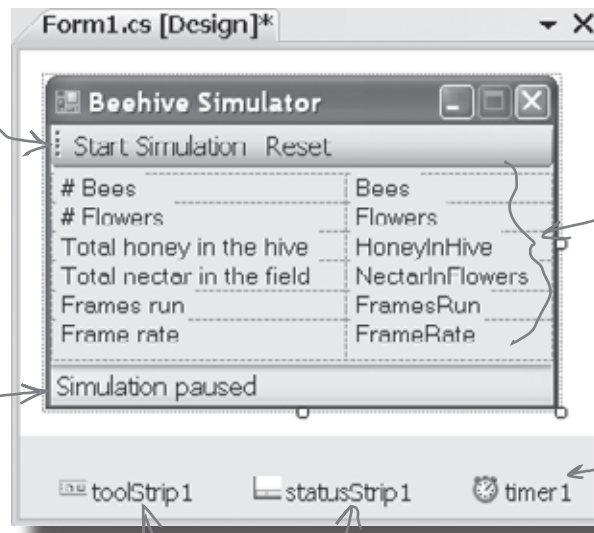

The `ToolStrip` control adds a toolbar to the top of your form, and `StatusStrip` adds a status bar to the bottom. But they also appear as icons in the area below the form, so you can edit their properties.

We're finally getting to the code that moves the World object along.

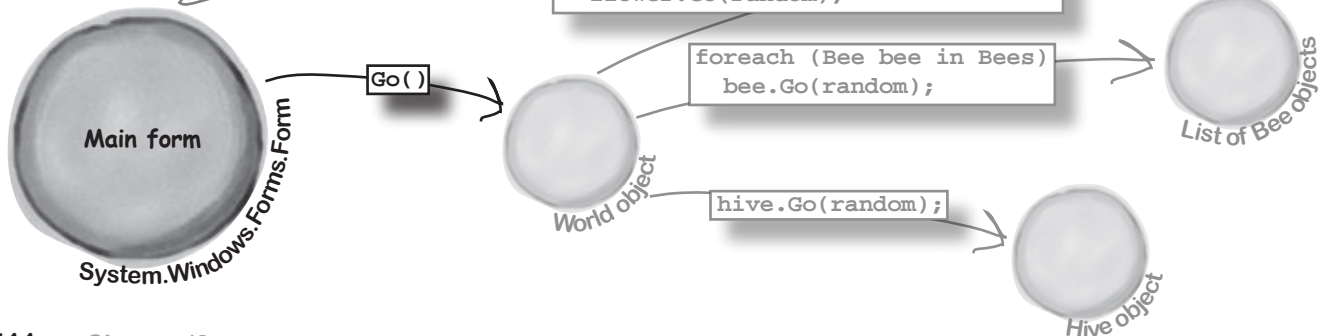

We can use World to get statistics

Now we want to update all these controls. But we don't need click handlers for each one; instead, let's use a single method that will update the different statistics in the simulator window:

```
private void UpdateStats(TimeSpan frameDuration) {
    Bees.Text = world.Bees.Count.ToString();
    Flowers.Text = world.Flowers.Count.ToString();
    HoneyInHive.Text = String.Format("{0:f3}", world.Hive.Honey);
    double nectar = 0;
    foreach (Flower flower in world.Flowers)
        nectar += flower.Nectar;
    NectarInFlowers.Text = String.Format("{0:f3}", nectar);
    FramesRun.Text = framesRun.ToString();
    double milliSeconds = frameDuration.TotalMilliseconds;
    if (milliSeconds != 0.0)
        FrameRate.Text = string.Format("{0:f0} ({1:f1}ms)",
            1000 / milliSeconds, milliSeconds);
    else
        FrameRate.Text = "N/A";
}
```

This indicates how long passes for a turn... we'll have to send this parameter in from somewhere else, in just a few pages.

Most of this just involves getting data from the world and updating labels.

Be sure you match your label names on the form with your code.

Print the first parameter as a number with no decimals, then a space, then print the second parameter with one decimal followed by the letters "ms" (in parentheses)

The frame rate is the number of frames run per second. We're using a TimeSpan object to store how long it took to run the frame. We divide 1000 by the number of milliseconds it took to run the frame—that gives us the total number of milliseconds it took to run the last frame.

Add this method into Form1.

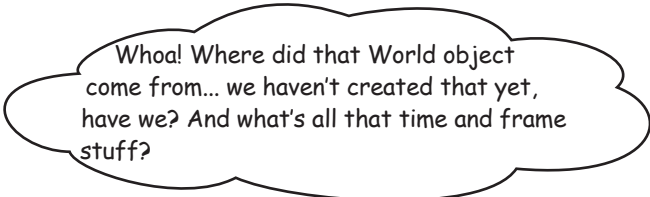

Let's create a World

You're right, we need to create the World object. Add this line to your form's constructor:

```
public Form1() {
    InitializeComponent();
    world = new World();
}
```

Go ahead and add a private World field to your form called world.

That just leaves all the time-related code. We've always said we needed a way to run Go() in World over and over... sounds like we need some sort of timer.

This code uses the same String.Format() method you used in the hex dump. But instead of printing in hex using "x2", you use "f3" to display a number with three decimal places.

We'll talk more about this when we create that TimeSpan object.



Take a minute and create a new project so you can see how timers work. Then we'll get back to the simulator and put your new knowledge to work.

Timers fire events over and over again

Remember how you used a loop to animate the greyhounds? Well, there's a better way to do it. A **Timer** is an especially useful component that triggers an event over and over again, up to a thousand times a second.



1 Create a new project with a timer and three buttons

You don't have to close your current project—just pop open a new Visual Studio and start up a new project. Drag a timer and three buttons onto the form. Click on the timer icon at the bottom of the designer and set its Interval property to 1000. That number is measured in milliseconds—it tells the timer to fire its tick event once a second.

2 Open the IDE's Properties window and click on the Events button.

(Remember, the Events button looks like a lightning bolt, and it lets you manage the events for any of your form's controls.) The timer control has exactly one event, Tick. **Click on the Timer** icon in the designer, then **double-click on its row** in the Events page,, and the IDE will create a new event handler method for you and hook it up to the property automatically.

The Events button in the Properties window lets you work with all the events for each of your controls.

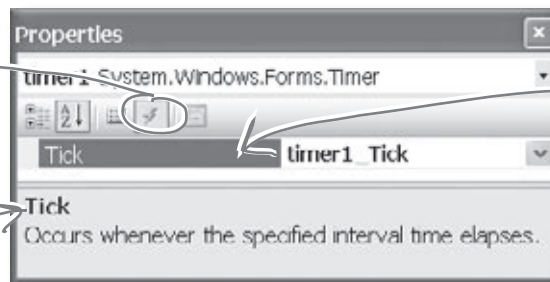

The Timer control has one event called Tick. If you double-click here, the IDE creates an event handler method for you automatically.

The bottom of the window has a description of the event.

3 Add code to the Tick event and to your buttons.

Here's some code that will help you get a sense of how the timer works:

```
private void timer1_Tick(object sender, EventArgs e) {
    Console.WriteLine(DateTime.Now.ToString());
}
private void toggleEnabled_Click(object sender, EventArgs e) {
    if (timer1.Enabled)
        timer1.Enabled = false;
    else
        timer1.Enabled = true;
}
private void startTimer_Click(object sender, EventArgs e) {
    timer1.Start();
    Console.WriteLine("Enabled = " + timer1.Enabled);
}
private void stopTimer_Click(object sender, EventArgs e) {
    timer1.Stop();
    Console.WriteLine("Enabled = " + timer1.Enabled);
}
```

These buttons let you play with the Enabled property and the Start() and Stop() methods. The first one switches Enabled between true and false, and the other two call the Start() and Stop() methods.

The timer's Enabled property starts and stops the timer.

This statement writes the current date and time to the output. Check the output window to make sure the tick event is fired once a second (every 1000 milliseconds).

The timer's Start() method starts the timer and sets Enabled to true. The Stop() method stops the timer and sets Enabled to false.

The timer's using a delegate behind the scenes

How do C# and .NET tell the timer what to do every tick? How does the `timer1_Tick()` method get run every time your timer ticks? Well, we're back to **events** and **delegates**, just like we talked about in the last chapter. Use the IDE's "Go To Definition" feature to remind yourself how the Event Handler delegate works:

The timer's Tick event is an average, everyday event handler, just like the ones to handle button clicks.

Behind the Scenes



4 Right-click on your timer1 variable and select "Go To Definition"

The "Go To Definition" feature will cause the IDE to automatically jump to the location in the code where the `timer1` variable is defined. The IDE will jump you to the code it created to add `timer1` as a property in the `Form1` object in `Form1.Designer.cs`. Scroll up in the file until you find this line:

```
this.timer1.Tick += new System.EventHandler(this.timer1_Tick);
```

This is the Tick event of your timer control. You've set this to occur every 1000 milliseconds.

Here's one of the System's delegates: the basic event handler. It's a delegate... a pointer to one or more methods.

Here's the method you just wrote, `timer1_Tick()`. You're telling the delegate to point to that method.

5 Now right-click on EventHandler and select "Go To Definition"

The IDE will automatically jump to the code that defines `EventHandler`. Take a look at the name of new tab that it opened to show you the code: "EventHandler [from metadata]". This means that the code to define `EventHandler` isn't in your code. It's built into the .NET framework, and the IDE generated a "fake" line of code to show you how it's represented:

```
public delegate void EventHandler(object sender, EventArgs e);
```

Each event is of type `EventHandler`. So our Tick event now points to the `timer1_Tick()` method.

Here's why every event in C# generally takes an `Object` and `EventArgs` parameter—that's the form of the delegate that C# defines for event handling.



What code would you write to run the `World's Go()` method every 500 milliseconds in our beehive simulator?

Add a Timer to the simulator

Let's add a timer to the simulator. You've already got a timer control, probably called `timer1`. Instead of using the IDE to generate a `timer1_Tick()` method, though, we can wire the timer to an event handler method called `RunFrame` manually:

TimeSpan has properties like Days, Hours, Seconds, and Milliseconds that let you measure the span in different units.

DateTime & TimeSpan

.NET uses the `DateTime` class to store information about a time, and its `Now` property returns the current date and time. If you want to find the difference between two times, use a `TimeSpan` object: just subtract one `DateTime` object from another, and that'll return a `TimeSpan` object that holds the difference between them.

```
public partial class Form1 : Form {
    World world;
    private Random random = new Random();
    private DateTime start = DateTime.Now;
    private DateTime end;
    private int framesRun = 0;

    public Form1() {
        InitializeComponent();
        world = new World();

        timer1.Interval = 50;
        timer1.Tick += new EventHandler(RunFrame);
        timer1.Enabled = false;
        UpdateStats(new TimeSpan());
    }

    private void UpdateStats(TimeSpan frameDuration) {
        // Code from earlier to update the statistics
    }

    public void RunFrame(object sender, EventArgs e) {
        framesRun++;
        world.Go(random);
        end = DateTime.Now;
        TimeSpan frameDuration = end - start;
        start = end;
        UpdateStats(frameDuration);
    }
}
```

You should have a World property from earlier.

These will be used to figure out how long the simulator's been running at any given point.

We want to keep up with how many frames-or turns-have passed.

Run every 50 milliseconds.

We set the handler to our own method, RunFrame().

Timer starts off.

We also start out by updating stats, with a new TimeSpan (0 time elapsed).

A second is 1000 milliseconds, so our timer will tick 20 times a second.

Increase the frame count, and tell the world to Go().

Next, we figure out the time elapsed since the last frame was run.

Finally, update the stats again, with the new time duration.



Your job is to write the event handlers for the **startSimulation** and **reset** buttons in the ToolStrip. Here's what each button should do:

1. Initially, the first button should read "Start Simulation." Pressing it causes the simulation to start, and the label to change to "Pause Simulation." If the simulation is paused, the button should read, "Resume simulation."

2. The second button should say "Reset." When it's pressed, the world should be recreated. If the timer is paused, the text of the first button should change from "Resume simulation" to "Start Simulation."

If you haven't dragged a ToolStrip and StatusStrip out of the toolbox and onto your form, do it now.

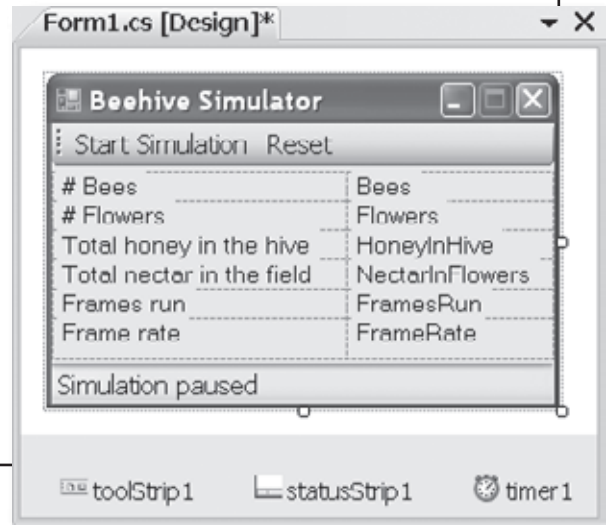

There's no single answer to this question—we just want you to think about what's left to do.



Just double-click on a ToolStrip button in the designer to make the IDE add its event handler, just like a normal button.

What do you think is left to be done in this phase of the simulator? Try running the program. Write down everything you think we still need to take care of before moving on to the graphical stuff.

.....

.....

.....

.....

.....

.....

.....

.....

there are no Dumb Questions

Q: We've been using the term "turn," but now you're talking about frames. What's the difference?

A: Semantics, really. We're still dealing in turns: little chunks of time where every object in the world gets to act. But since we'll soon be putting some heavy-duty graphics in place, we've started using "frame", as in a graphical game's frame-rate.



Exercise Solution

Your job was to write the event handlers for the Start Simulation and Reset buttons.

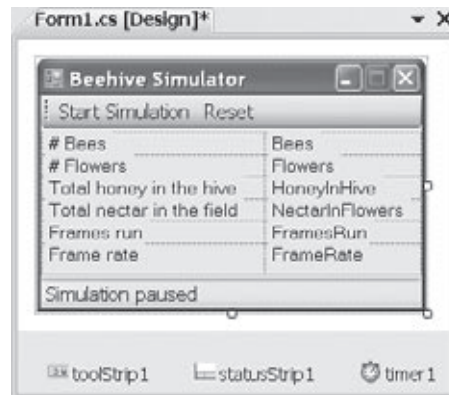

```
public partial class Form1 : Form {
    // variable declarations

    public Form1() {
        InitializeComponent();
        world = new World();
    }
    private void Form1_Load(object sender, EventArgs e) {
        // code to start simulator
    }
    private void UpdateStats(TimeSpan frameDuration) {
        // Code from earlier to update the statistics
    }
    public void RunFrame(object sender, EventArgs e) {
        // event handler for timer
    }

    private void startSimulation_Click(object sender, EventArgs e) {
        if (timer1.Enabled) {
            toolStrip1.Items[0].Text = "Resume simulation";
            timer1.Stop();
        } else {
            toolStrip1.Items[0].Text = "Pause simulation";
            timer1.Start();
        }
    }

    private void reset_Click(object sender, EventArgs e) {
        framesRun = 0;
        world = new World();
        if (!timer1.Enabled)
            toolStrip1.Items[0].Text = "Start simulation";
    }
}
```

Be sure your form's control names match up with what you use in your code.

Toggle the timer, and update the message.

Resetting the simulator is just a matter of recreating the World instance and resetting framesRun.

The only time we need to change the first button's label is if it says, "Resume simulation." If it says, "Pause simulation," it doesn't need to change.

Test drive

You've done a ton of work. Compile your code, fix any typos, and run the simulator. How's it look?

Looks pretty good! All these numbers should update as the world moves along.

Your start/pause and reset buttons should all work.

Beehive Simulator	
Resume simulation Reset	
# Bees	6
# Flowers	10
Total honey in the hive	0.200
Total nectar in the field	31.700
Frames run	275
Frame rate	25 (40.1ms)
Simulation paused	

Hmmm... our status strip seems to be the only thing not working.



Exercise

Here's your chance to put together everything you've learned. We need to allow bees to tell our simulator what they're doing. When they do, we want our simulator to update the status message in the simulator.

This time, it's up to you to not only write most of the code, but figure out what code you need to write. How can you have a method in your simulator that gets called everytime a bee changes its state?

To give you a little help, we've written the method to add to the form. The Bee class should call this method any time its state changes:

```
private void SendMessage(int ID, string Message) {
    statusStrip1.Items[0].Text = "Bee #" + ID + ": " + Message;
}
```

* Okay, one more hint. You'll need to make changes to all but one of your classes to make this work.



Exercise Solution

Your job was to come up with a way for Bees to let the simulator know about what they're doing.

Here's what we added to the Bee class.

```
public class Bee {
    // all our existing code
    public delegate void BeeMessage(int ID, string Message);
    public BeeMessage MessageSender;

    public void Go(Random random) {
        Age++;
        BeeState oldState = CurrentState;
        switch (currentState) {
            // the rest of the switch statement is the same
        }
        if (oldState != CurrentState
            && MessageSender != null)
            MessageSender(ID, CurrentState.ToString());
    }
}
```

We used a **callback** to hook each individual bee object up to the form's `SendMessage()` method.

`BeeMessage` is our delegate. It's also a match with the `SendMessage()` method we wrote in the form.

If the status of the Bee changed, we call back the method our `BeeMessage` delegate points to, and let that method know about the status change.

Here are the changes we made to the Hive.

```
public class Hive {
    // all our existing code
    public Bee.BeeMessage MessageSender;

    public Hive(World world, Bee.BeeMessage MessageSender) {
        this.MessageSender = MessageSender;
        // existing constructor code
    }

    public void AddBee(Random random) {
        // existing AddBee() code
        Bee newBee = new Bee(beeCount, startPoint, world, this);
        newBee.MessageSender += this.MessageSender;
        world.Bees.Add(newBee);
    }
}
```

Hive needs a delegate too, so it can pass on the methods for each bee to call when they're created in `AddBee()`.

`AddBee()` now has to make sure that each new bee gets the method to point at.

The World class required some changes as well.

```

public class World {
    // all our existing code

    public World(Bee.BeeMessage messageSender) {
        Bees = new List<Bee>();
        Flowers = new List<Flower>();
        Hive = new Hive(this, messageSender);
        Random random = new Random();
        for (int i = 0; i < 10; i++)
            AddFlower(random);
    }
}

```

World doesn't need to have a delegate of its own. It just passes on the method to call to the Hive instance.

Last but not least, here's the updated form. Anything not shown stayed the same.

```

public partial class Form1 : Form {
    // variable declarations

    public Form1() {
        InitializeComponent();
        world = new World(new Bee.BeeMessage(SendMessage));
        // the rest of the Form1 constructor
    }
}

```

We create a new delegate from the Bee class (make sure you declared BeeMessage public), and point it at our SendMessage() method.

```

private void reset_Click(object sender, EventArgs e) {
    framesRun = 0;
    world = new World(new Bee.BeeMessage(SendMessage));
    if (!timer1.Enabled)
        toolStrip1.Items[0].Text = "Start simulation";
}

```

Same thing here... create the world with the method for bees to call back.

```

private void SendMessage(int ID, string Message) {
    statusStrip1.Items[0].Text = "Bee #" + ID + ": " + Message;
}
}

```

This is the method we gave you... be sure to add it in, too.

Let's work with groups of bees

Your bees should be buzzing around the hive and the field, and your simulation should be running! How cool is that? But since we don't have the visual part of the simulator working yet—that's what we're doing in the next chapter—all the information we have so far is the messages that the bees are sending back to the main form with their callback. So let's add more information about what the bees are doing.

You already have the form updating these stats and displaying the messages that the bees send as they do their jobs.

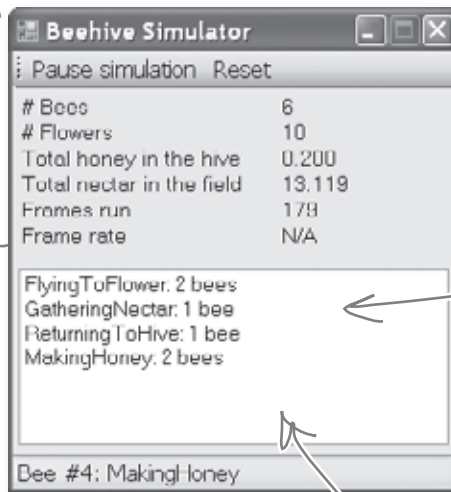

Go ahead and add a `ListBox` to your form. We'll use it to display some extra stats about the bees in the world.

At any time, there are a bunch of bees flying around. The new `ListBox` will display how many bees are doing each job. In this case, two bees are flying to flowers, one is at a flower gathering nectar, one is returning to the hive, and two are in the honey factory turning nectar into honey.



You know enough to gather the information you'd need to populate that `ListBox`—take a minute and think through how that would work. But it's a little more complex than it seems at first. What would you need to do to figure out how many bees are in each of the various `Bee.State` states?

A collection collects... DATA

Our bees are stored in a List, which is one of C#'s collection types. And collection types really just store data... a lot like a database does. So each bee is like a row of data, complete with a state, and ID, and so on. Here's how our bees look as a collection of objects:

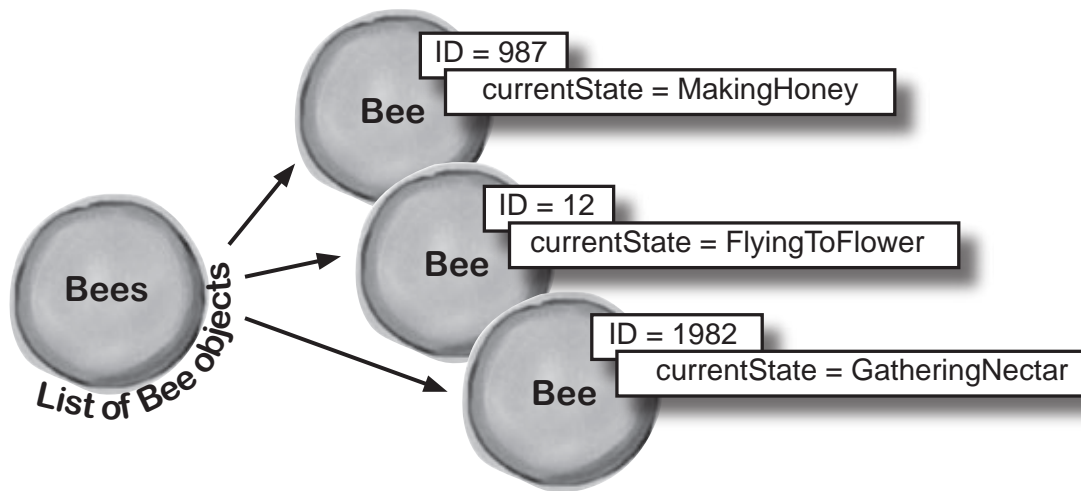

There's a lot of data in the Bee objects' fields. You can *almost* think of a collection of objects the same way you think of rows in a database. Each object holds data in its fields, the same way each row in a database holds data in its columns.

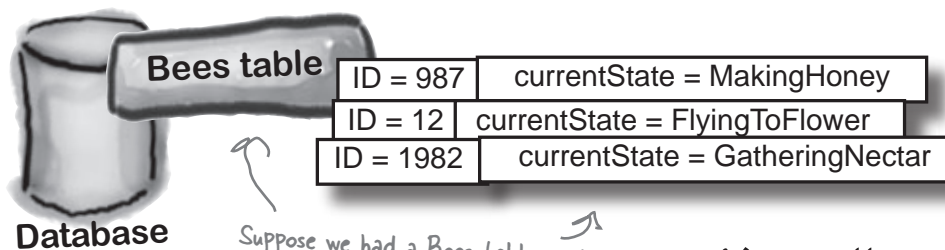

Suppose we had a *Bees* table, and each row in the table had an *ID* column and a *currentState* column.

Most collections—especially when they hold objects—can be thought of as data stores, just like a database.



Who cares if you can **think** about a collection as a database if you can't **use** a collection like a database? What a total waste of time...

What if you could query collections, databases, and even XML documents with the same basic syntax?

C# has a really useful feature called **LINQ** (which stands for **L**anguage **I**ntegrated **Q**uery). The idea behind LINQ is that it gives you a way to take an array, list, stack, queue, or other collection and work with all the data inside it all at once in a single operation.

But what's really great about LINQ is that you can use the same syntax that works with collections as you can for working with databases.



LINQ is a new feature that's part of C# 3.0 and Visual Studio 2008.

If you're using an earlier version of C#, take a few minutes to download and install Visual C# 2008 Express Edition. It's free from Microsoft, and it can be installed alongside previous versions.

We'll spend most of Chapter 15 working with LINQ.

This LINQ query works essentially the same with data in a collection or a database.

```
var beeGroups =
    from bee in world.Bees
    group bee by bee.CurrentState
    into beeGroup
    orderby beeGroup.Key
    select beeGroup;
```

LINQ

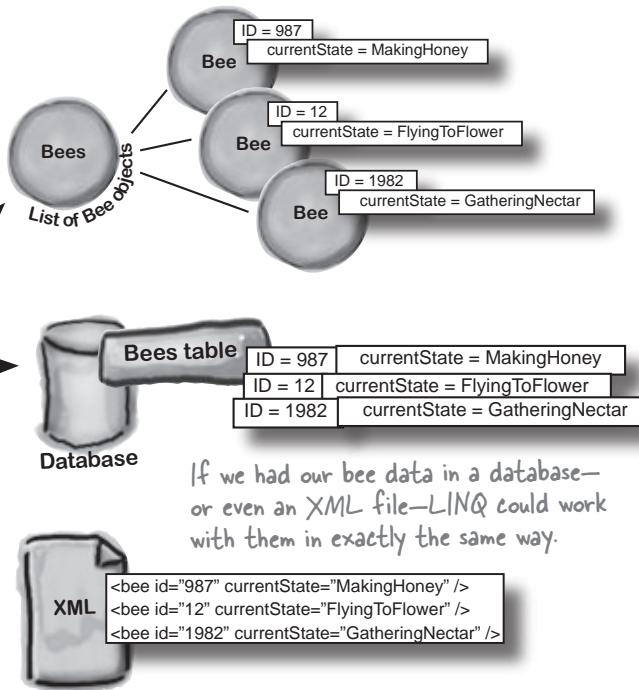

LINQ makes working with data in collections and databases easy

We're going to spend an entire chapter on LINQ before long, but we can use LINQ and some Ready Bake Code to add some extra features to our simulator. Ready Bake Code is code you should type in, and it's okay if you don't understand it all. You'll learn how it all works in Chapter 15.



Ready Bake Code

```
private void SendMessage(int ID, string Message) {
    statusStrip1.Items[0].Text = "Bee #" + ID + ": " + Message;
    var beeGroups =
        from bee in world.Bees
        group bee by bee.CurrentState into beeGroup
        orderby beeGroup.Key
        select beeGroup;
    listBox1.Items.Clear();
    foreach (var group in beeGroups) {
        string s;
        if (group.Count() == 1)
            s = "";
        else
            s = "s";
        listBox1.Items.Add(group.Key.ToString() + ": "
            + group.Count() + " bee" + s);
        if (group.Key == BeeState.Idle
            && group.Count() == world.Bees.Count()
            && framesRun > 0) {
            listBox1.Items.Add("Simulation ended: all bees are idle");
            toolStrip1.Items[0].Text = "Simulation ended";
            statusStrip1.Items[0].Text = "Simulation ended";
            timer1.Enabled = false;
        }
    }
}
```

Make sure this matches the list box control's name on your form.

This is a LINQ query. It takes all the bees in the Bees collection, and groups them by their CurrentState property.

The group's Key is the bee's CurrentState, so that's the order the states will be displayed on the form.

beeGroups is from the LINQ query. We can count the members, and iterate over them.

This bit of code makes sure it says, "1 bee" and "3 bees", keeping the plural right.

Finally, add the group status (its key) and count to the list box.

Here's another nice feature. Since we know how many bees are idle... we can see if ALL bees are idle. If so, the hive's out of honey, so let's stop the simulation.



We'll learn a lot more about LINQ in upcoming chapters.

You don't need to memorize LINQ syntax or try to drill all of this into your head right now. You'll get a lot more practice working with LINQ in Chapter 15.

Test drive (Part 2)

Go ahead and compile your code and run your project. If you get any errors, double-check your syntax, especially with the new LINQ code. Then, fire up your simulator!

The screenshot shows a window titled "Beehive Simulator" with a menu bar containing "Pause simulation" and "Reset". The main area displays a table of statistics and a list of bee activities. Handwritten annotations explain the data flow: a timer on the form controls the simulation; LINQ queries feed data from collections every turn; stats are queried from the World object; and bees call back the simulator to update their status.

Statistic	Value
# Bees	6
# Flowers	10
Total honey in the hive	0.200
Total nectar in the field	13.119
Frames run	179
Frame rate	N/A

FlyingToFlower: 2 bees
GatheringNectar: 1 bee
ReturningToHive: 1 bee
MakingHoney: 2 bees

Bee #4: MakingHoney

The timer on your form controls the running of the simulation.

These stats come from the form querying the World object.

LINQ queries your collections to feed you this data every turn.

Bees call back your simulator form to update the form every time their status changes.

One final challenge: Open and Save

We're almost ready to take on graphics, and add some visual eye candy to our simulator. First, though, let's do one more thing to this version: allow loading, saving, and printing of bee statistics.

1 Add the Open, Save, and Print icons

The ToolStrip control has a really useful feature—it can automatically insert picture buttons for standard icons: new, open, save, print, cut, copy, paste, and help. Just right-click on the ToolStrip icon at the bottom of the Form Designer window and select “Insert Standard Items”. Then click on the first item—that’s the “new” icon—and delete it. Keep the next three items, because they’re the ones we need (open, save and print). After that comes a separator; you can either delete it or move it between the Reset button and the save button. Then delete the rest of the buttons.

You'll add the Print button now—we'll make it print a status page for the hive in the next chapter.

2 Add the button event handlers

The new standard buttons are named `openToolStripButton`, `saveToolStripButton` and `printToolStripButton`. Just double-click on them to add their event handlers.



Exercise

Add code to make the save and open buttons work.

1. **Make the save button serialize the world to a file.** Stop the timer (you can restart it after saving). Set `MessageSender` to `null` for the hive and all the bees, so .NET doesn't try and serialize the code your delegates point to: the form itself. Display a Save dialog box, and then serialize the `World` object, and the number of frames that have been run. Don't forget to reattach the `SendMessage()` when you're done saving.
2. **Make the open button deserialize the world from a file.** Take care of the timer just like in the save button, pop up an Open dialog box, and deserialize the world and the number of frames run from the selected file. Then you can hook up the `MessageSender` delegates again and restart the timer (if necessary).
3. **Don't forget about exception handling!** Make sure the world is intact if there's a problem reading or writing the file. Consider popping up a human-readable error message indicating what went wrong.



Exercise Solution

Your job was to make the Save and Open buttons work.

Don't forget the extra using statements.

```
using System.IO;
using System.Runtime.Serialization.Formatters.Binary;
```

You'll need to make the World, Hive, Flower, and Bee classes serializable. When you serialize the world, .NET will find its references to Hive, Flower and Bee objects and serialize them too.

```
[Serializable]
public class World {
[Serializable]
public class Hive {
[Serializable]
public class Flower {
[Serializable]
public class Bee {
```

Here's the code for the Save button.

```
private void saveToolStripButton_Click(object sender, EventArgs e) {
    bool enabled = timer1.Enabled;
    if (enabled)
        timer1.Stop();
    world.Hive.MessageSender = null;
    foreach (Bee bee in world.Bees)
        bee.MessageSender = null;
```

If we don't set all the MessageSender delegates to null, then when we try to serialize the world they'll act as a reference to Form1, and the BinaryFormatter will try to write out our form.

```
SaveFileDialog saveDialog = new SaveFileDialog();
saveDialog.Filter = "Simulator File (*.bees)|*.bees";
saveDialog.CheckPathExists = true;
saveDialog.Title = "Choose a file to save the current simulation";
if (saveDialog.ShowDialog() == DialogResult.OK) {
    try {
        BinaryFormatter bf = new BinaryFormatter();
        using (Stream output = File.OpenWrite(saveDialog.FileName)) {
            bf.Serialize(output, world);
            bf.Serialize(output, framesRun);
        }
    }
    catch (Exception ex) {
        MessageBox.Show("Unable to save the simulator file\r\n" + ex.Message,
            "Bee Simulator Error", MessageBoxButtons.OK, MessageBoxIcon.Error);
    }
}
world.Hive.MessageSender = new Bee.BeeMessage(SendMessage);
foreach (Bee bee in world.Bees)
    bee.MessageSender = new Bee.BeeMessage(SendMessage);
if (enabled)
    timer1.Start();
```

We decided to use "bees" as the extension for simulator save files.

Here's where the world is written out to a file.

Remember, when we serialize World, everything it references gets serialized... all the bees, flowers, and the hive.

After we save the file, we need to hook up the MessageSender delegates again, and then restart the timer (if we stopped it).

```

private void openToolStripButton_Click(object sender, EventArgs e) {
    World currentWorld = world;
    int currentFramesRun = framesRun;

    bool enabled = timer1.Enabled;
    if (enabled)
        timer1.Stop();

    OpenFileDialog openFileDialog = new OpenFileDialog();
    openFileDialog.Filter = "Simulator File (*.bees)|*.bees";
    openFileDialog.CheckPathExists = true;
    openFileDialog.CheckFileExists = true;
    openFileDialog.Title = "Choose a file with a simulation to load";
    if (openFileDialog.ShowDialog() == DialogResult.OK) {
        try {
            BinaryFormatter bf = new BinaryFormatter();
            using (Stream input = File.OpenRead(openFileDialog.FileName)) {
                world = (World)bf.Deserialize(input);
                framesRun = (int)bf.Deserialize(input);
            }
        } catch (Exception ex) {
            MessageBox.Show("Unable to read the simulator file\r\n" + ex.Message,
                "Bee Simulator Error", MessageBoxButtons.OK, MessageBoxIcon.Error);
            world = currentWorld;
            framesRun = currentFramesRun;
        }
    }

    world.Hive.MessageSender = new Bee.BeeMessage(SendMessage);
    foreach (Bee bee in world.Bees)
        bee.MessageSender = new Bee.BeeMessage(SendMessage);
    if (enabled)
        timer1.Start();
}

```

Here's the code for the Open button.

Before opening the file and reading from it, save a reference to the current world and framesRun. If there's a problem, you can revert to these and keep running.

Set up the Open File dialog box and pop it up.

using ensures the stream gets closed.

Here's where we deserialize the world and the number of frames run to the file.

If the file operations throw an exception, we restore the current world and framesRun.

Once everything is loaded, we hook back up the delegates and restart the timer.

You'll need to get your simulator up and running before you move on to the next chapter. You can download a working version from the Head First Labs website: www.headfirstlabs.com/books/hfcsharp/

13 controls and graphics

✦ ✦ ✦
Make it pretty ✦ ✦ ✦
✦



Sometimes you have to take graphics into your own hands.

We've spent a lot of time on relying on controls to handle everything visual in our applications. But sometimes that's not enough—like when you want to **animate a picture**. And once you get into animation, you'll end up **creating your own controls** for your .NET programs, maybe adding a little **double buffering**, and even **drawing directly onto your forms**. It all begins with the **Graphics** object, **Bitmaps**, and a determination to not accept the graphics status quo.

You've been using controls all along to interact with your programs

TextBoxes, PictureBoxes, Labels... you've got a pretty good handle by now on how you can use the controls in the IDE's toolbox. But what do you *really* know about them? There's a lot more to a control than just dragging an icon onto your form.



You can create your own controls

The controls in the toolbox are really useful for building forms and applications, but there's nothing magical about them. They're just classes, like the classes that you've been writing on your own. In fact, C# makes it really easy for you to create controls yourself, just by inheriting from the right base class.



Your custom controls show up in the IDE's toolbox

There's also nothing mysterious about the toolbox in the IDE. It just looks in your project's classes and the built-in .NET classes for any controls. If it finds a control—a class that implements the right interface—then it displays an icon for the class. If you add your own custom controls, they'll show up in the toolbox, too.

You can create a class that inherits from any of the existing control classes—even if it doesn't have any other code in it—and it'll automatically show up in the toolbox.



You can write code to add controls to your form, and even remove controls, while your program's running

Just because you lay out a form in the IDE's form designer, that doesn't mean that it has to stay like that. You've already moved plenty of PictureBox controls around (like when you built the greyhound race). But you can also add or remove controls, too. In fact, when you build a form in the IDE, all it's doing is writing the code that adds the controls to the form... which means you can write similar code, and run that code whenever you want.

Form controls are just objects

You already know how important **controls** are to your forms. You've been using buttons, text boxes, picture boxes, check boxes, group boxes, labels, and other forms since chapter 1. Well, it turns out that those controls are just objects, just like everything else you've been working with.

A control is just an object, like any other object—it just happens to know how to draw itself. The `Form` object keeps track of its controls using a special collection called **Controls**, which you can use to add or remove controls in your own code.

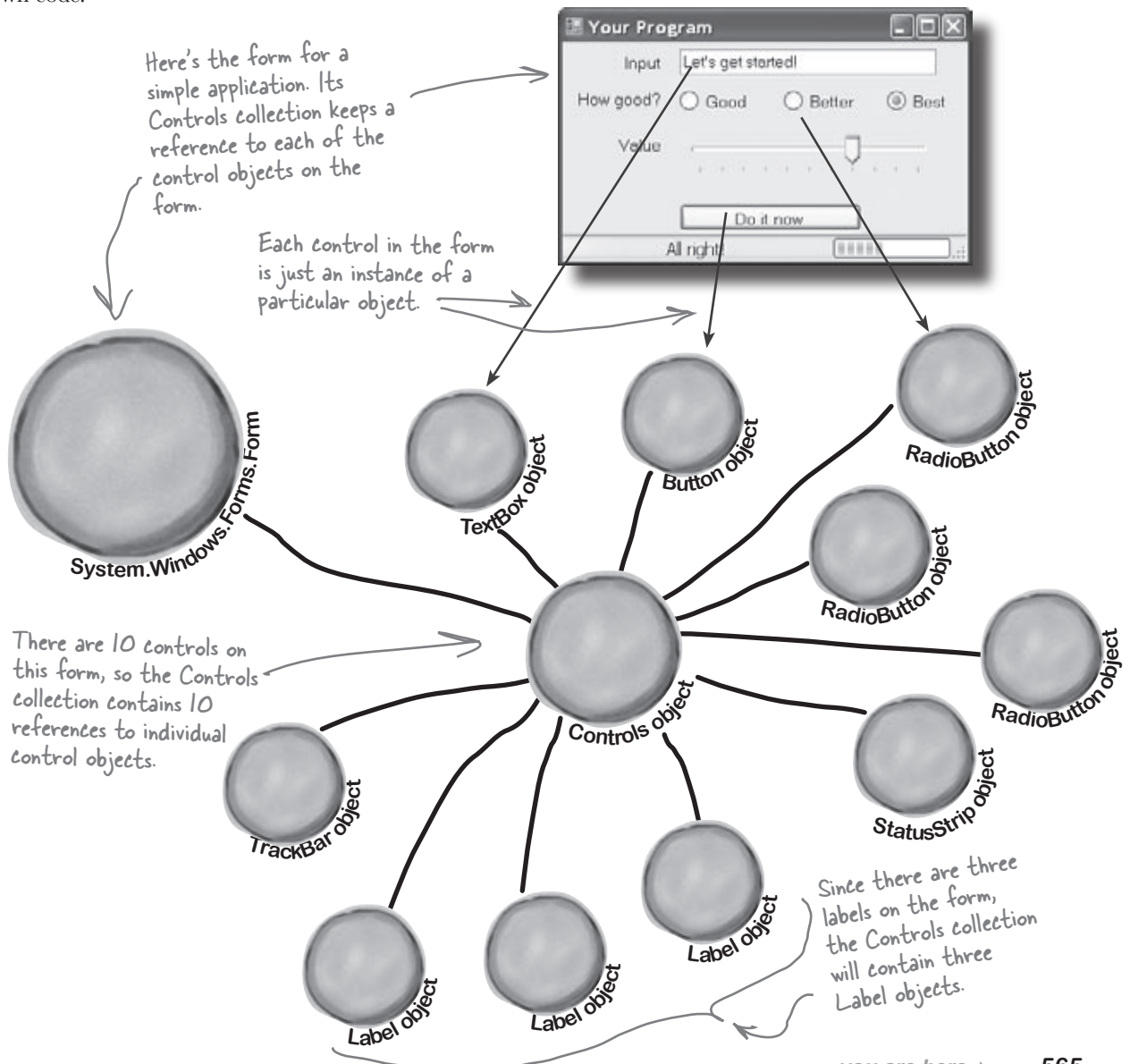

Use controls to animate the beehive simulator

You've built a cool simulator, but it's not much to look at. It's time to create a really stunning visualization that shows those bees in action. You're about to build a renderer that animates the beehive...and controls are the key.

1 The user interface shows you everything that's going on

Your simulator will have three different windows. You've already built the main “heads-up display” stats window that shows stats about the current simulation and updates from the bees. Now you'll add a window that shows you what's going on inside the hive, and a window that shows the field of flowers where the bees gather nectar.

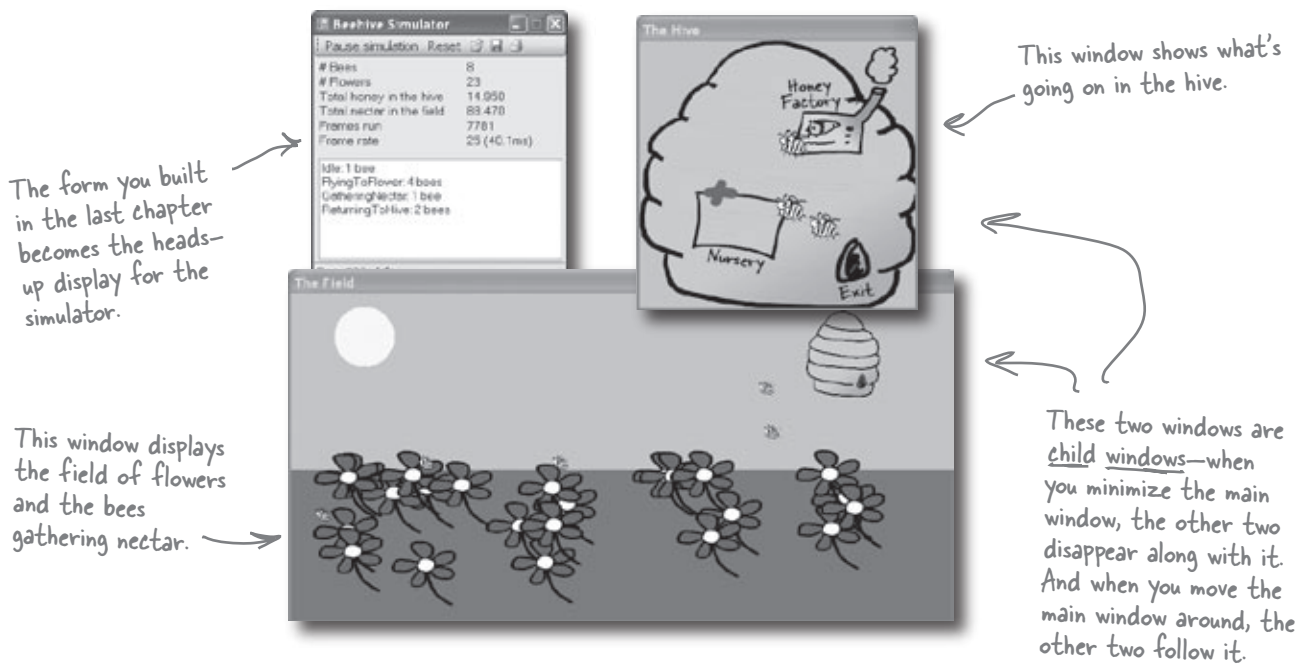

2 We'll make the Print button in the stats window work

The stats window has working Open and Save buttons, but the Print button doesn't work yet. We'll be able to reuse a lot of the graphics code to get the Print button on the ToolStrip to print an info page about what's going on.

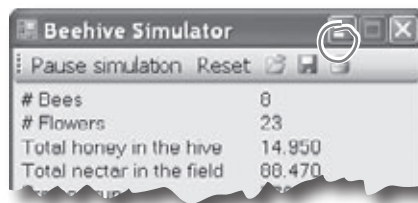

3 The hive window shows you what's going on inside the hive

As the bees fly around the world, you'll need to animate each one. Sometimes they're inside the hive, and when they are, they show up in this window.



The hive has three important locations in it. The bees are born in the nursery, they have to fly to the exit to leave the hive to gather nectar from the flowers, and when they come back they need to go to the honey factory to make honey.

The hive exit is on the hive form, and the entrance is on the field form. (That's why we put both of them in the Hive's locations dictionary.)

Here's the entrance to the hive. When bees fly into it, they disappear from the field form and reappear near the Exit in the hive form.

4 The field window is where the bees collect the nectar

Bees have one big job: collect nectar from the flowers, and bring it back to the hive to make honey. Then they eat honey to give them energy to fly out and get more nectar.

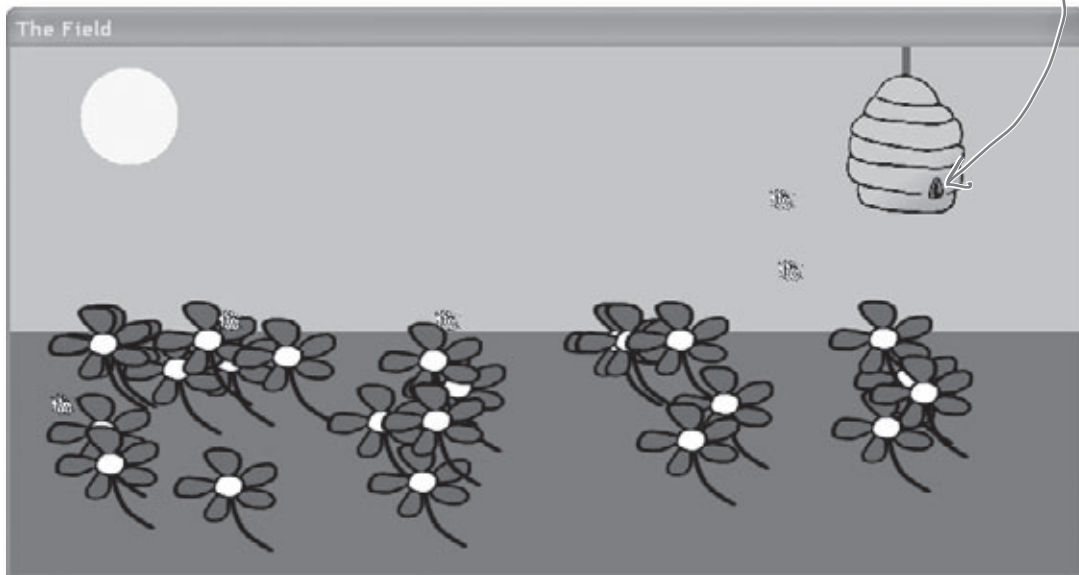

Add a renderer to your architecture

We need another class that reads the information in the world and uses it to draw the hive, bees and flowers on the two new forms. We'll add a class called **Renderer** to do exactly that. And since your other classes are well-encapsulated, that won't require a lot of changes to your existing code.

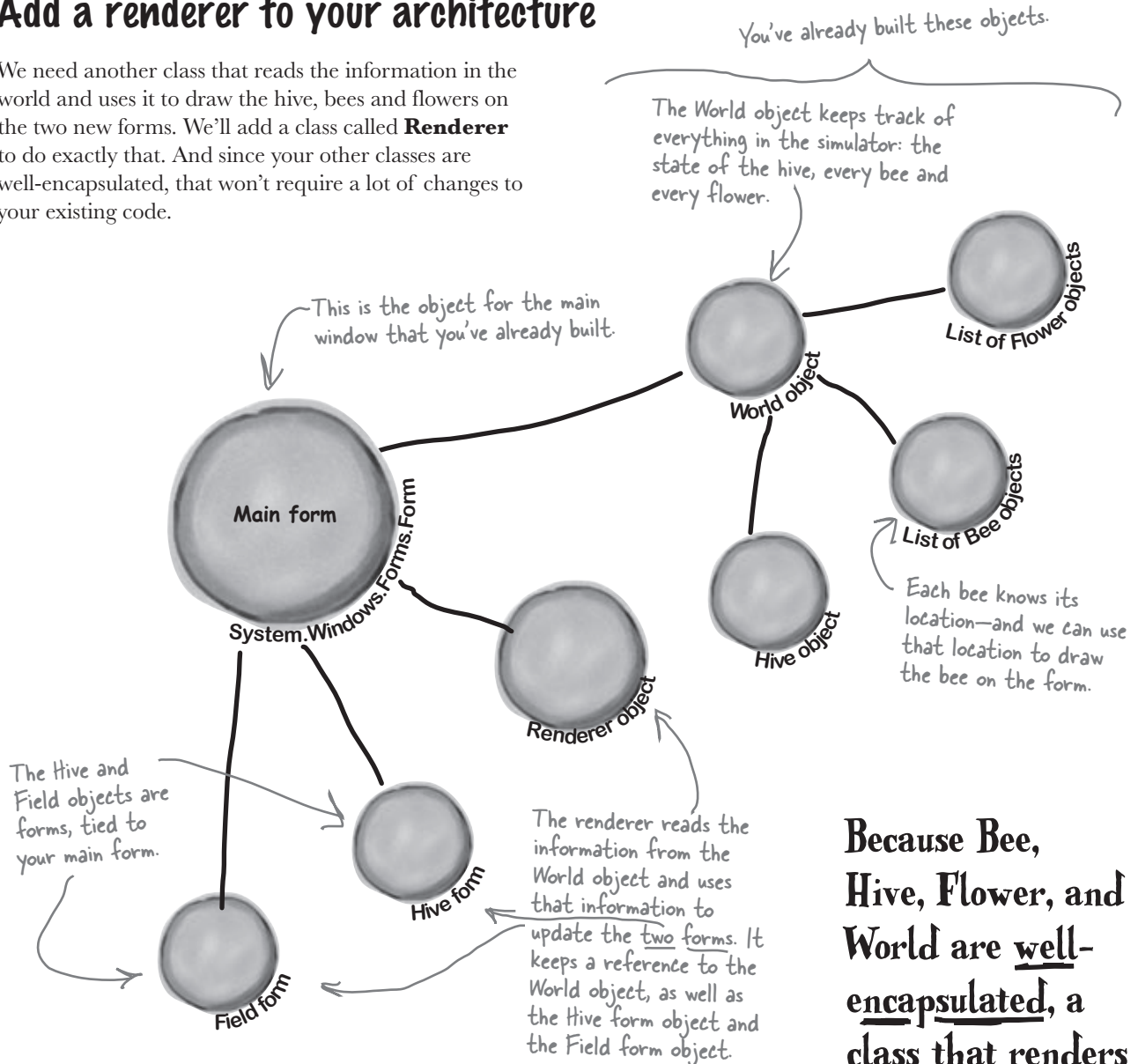

Because Bee, Hive, Flower, and World are well-encapsulated, a class that renders those objects can be added without lots of changes to existing code.

ren-der, verb.

to represent or depict artistically. Sally's art teacher asked the class to look at all of the shadows and lines in the model and **render** them on the page.

The renderer draws everything in the World on the two forms

The `World` object keeps track of everything in the simulation: the hive, the bees, and the flowers. But it doesn't actually draw anything or produce any output. That's the job of the `Renderer` object. It reads all of the information in the `World`, `Hive`, `Bee`, and `Flower` objects and draws them on the forms.

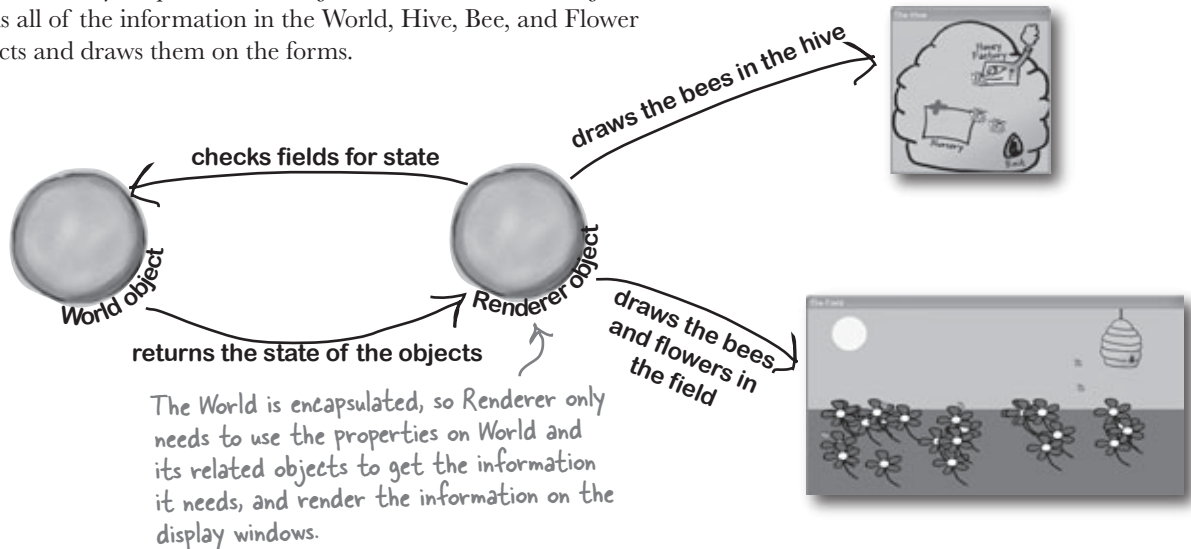

The simulator renders the world after each frame

After the main form calls the world's `Go()` method, it should call the renderer's `Render()` method to redraw the display windows. For example, each flower will be displayed using a `PictureBox` control. But let's go further with bees and create an animated control. You'll create this new control, called `BeeControl`, and define its behavior yourself.

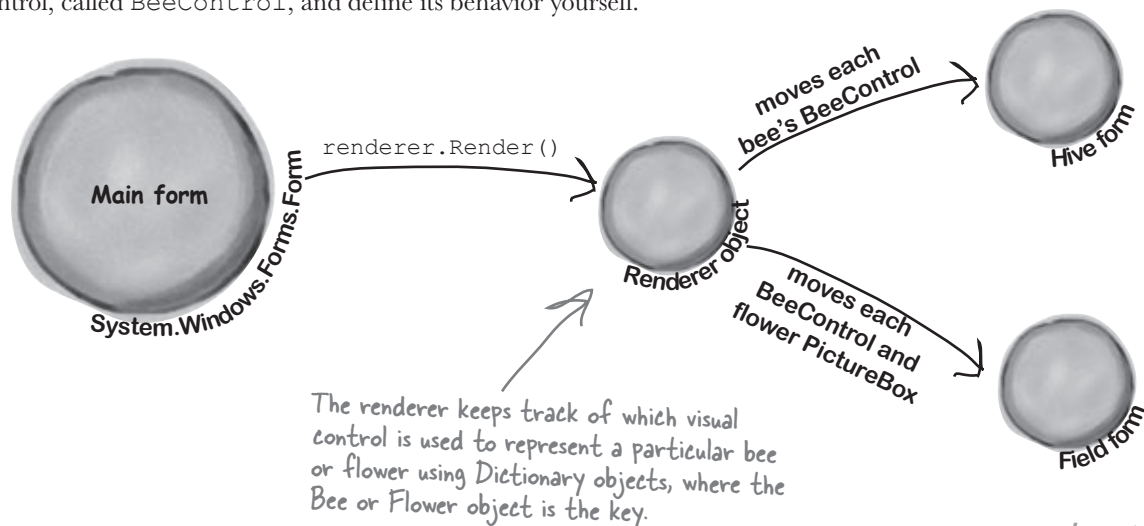

Controls are well-suited for visual display elements

When a new bee is added to the hive, we'll want our simulator to add a new `BeeControl` to the Hive form and change its location as it moves around the world. When that bee flies out of the hive, our simulator will need to remove the control from the Hive form and add it to the Field form. And when it flies back to the hive with its load of nectar, its control needs to be removed from the Field form and added back to the Hive form. And all the while, we'll want the animated bee picture to flap its wings... and controls will make it easy to do all of that.

- 1 The world adds a new bee, and the renderer creates a new `BeeControl` and adds it to the Hive form's `Controls` collection.

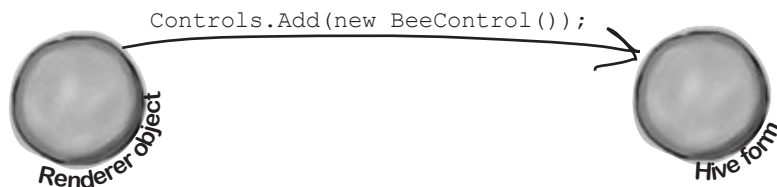

- 2 When the bee flies out of the hive and enters the field, the renderer removes the `BeeControl` from the hive's `Controls` collection and adds it to the field form's `Controls` collection.

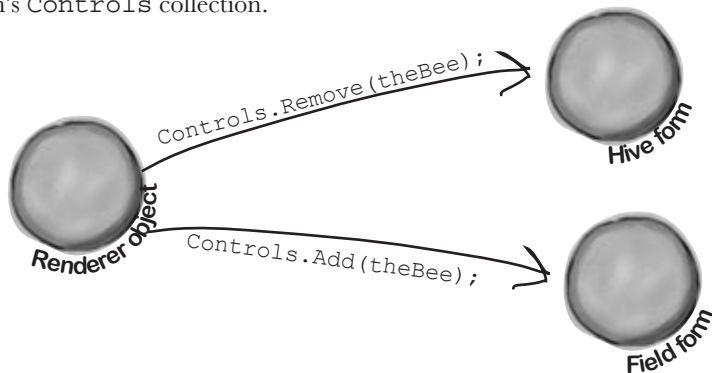

- 3 A bee will retire if it's idle and it's gotten too old. If the renderer checks the world's Bees list and finds that the bee is no longer there, it removes the control from the Hive form.

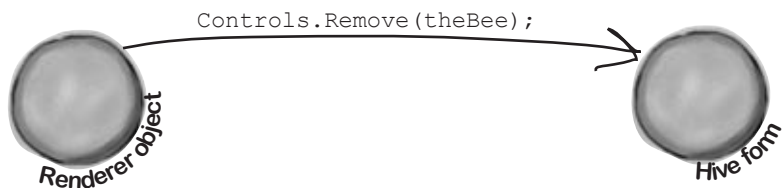



Can you figure out what each of these code snippets does? Assume each snippet is inside a form, and write down your best guess.

```
this.Controls.Add(new Button());
```

.....

```
Form2 childWindow = new Form2();
childWindow.BackgroundImage =
    Properties.Resources.Mosaic;
childWindow.BackgroundImageLayout =
    ImageLayout.Tile;
childWindow.Show();
```

.....

*If you've got a ListBox on your form,
 you can use its AddRange() method
 to add list items.*

```
Label myLabel = new Label();
myLabel.Text = "What animal do you like?";
myLabel.Location = new Point(10, 10);
ListBox myList = new ListBox();
myList.Items.AddRange( new object[]
    { "Cat", "Dog", "Fish", "None" } );
myList.Location = new Point(10, 40);
Controls.Add(myLabel);
Controls.Add(myList);
```

.....

*You don't need to write down
 each line, as much as summarize
 what's going on in the code block.*

```
Label controlToRemove = null;
foreach (Control control in Controls) {
    if (control is Label
        && control.Text == "Bobby")
        controlToRemove = control as Label;
}
Controls.Remove(controlToRemove);
controlToRemove.Dispose();
```

.....

Bonus question: Why do you think we didn't put the Controls.Remove() statement inside the foreach loop?

.....

*Try it out if you want, and
 write why you think you got the
 result that .NET gave you.*



Sharpen your pencil Solution

Can you figure out what each of these code snippets does? Assume each snippet is inside a form, and write down what you think it does.

```
this.Controls.Add(new Button());
```

Create a new button and add it to the form. It'll have default values (e.g., the Text property will be empty).

```
Form2 childWindow = new Form2();
childWindow.BackgroundImage =
    Properties.Resources.Mosaic;
childWindow.BackgroundImageLayout =
    ImageLayout.Tile;
childWindow.Show();
```

There's a second Form in the application called Form2, so this creates it, sets its background image to a resource image called "Mosaic", makes the background image so it's tiled instead of stretched, and then displays the window to the user.

```
Label myLabel = new Label();
myLabel.Text = "What animal do you like?";
myLabel.Location = new Point(10, 10);
ListBox myList = new ListBox();
myList.Items.AddRange( new object[]
    { "Cat", "Dog", "Fish", "None" } );
myList.Location = new Point(10, 40);
Controls.Add(myLabel);
Controls.Add(myList);
```

This code creates a new label, sets its text, and moves it to a new position. Then it creates a new listbox, adds four items to the list, and moves it just underneath the label. It adds the label and listbox to the form, so they both get displayed immediately.

```
Label controlToRemove = null;
foreach (Control control in Controls) {
    if (control is Label
        && control.Text == "Bobby")
        controlToRemove = control as Label;
}
Controls.Remove(controlToRemove);
controlToRemove.Dispose();
```

What happens there's no control named "Bobby" in the Controls collection?

This loop searches through all the controls on the form until it finds a label with the text "Bobby". Once it finds the label, it removes it from the form.

If you try, .NET will throw an exception: It needs the collection intact, otherwise it'll lose its place and give you unpredictable results. That's why you'd use a for loop for this instead.

Bonus question: Why do you think we didn't put the Controls.Remove() statement inside the foreach loop?

You can't modify the Controls collection (or any other collection) in the middle of a foreach loop that's iterating through it.

Build your first animated control

You're going to **build your own control** that draws an animated bee picture. If you've never done animation, it's not as hard as it sounds: you draw a sequence of pictures one after another, and produce the illusion of movement. Lucky for us, the way C# and .NET handle resources makes it really easy for us to do animation.

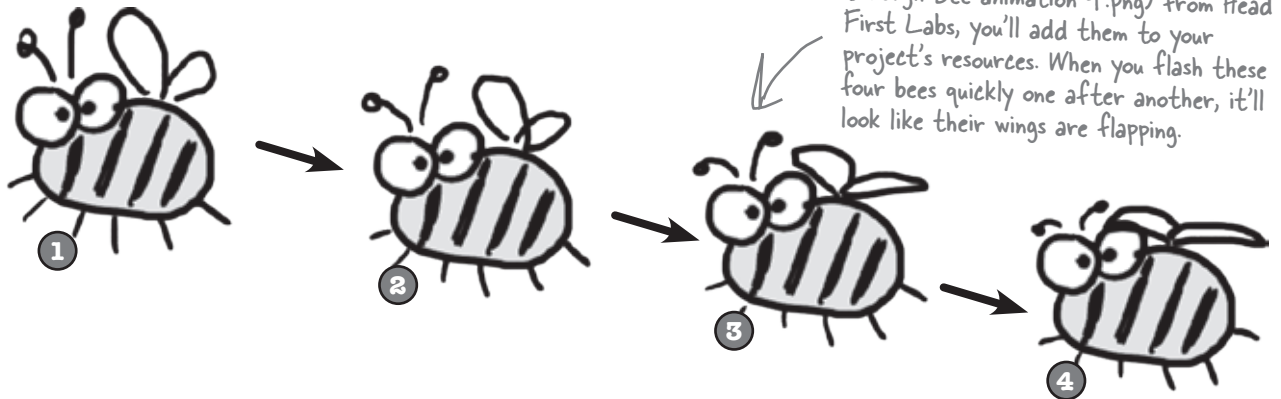

We want a control in the toolbox

If you build `BeeControl` right, it'll appear as a control that you can drag out of your toolbox and onto your form. It'll look just like a `PictureBox` showing a picture of a bee, except that it'll have animated flapping wings.

Download the images for this chapter from the Head First Labs website:
www.headfirstlabs.com/books/hfcsharp/

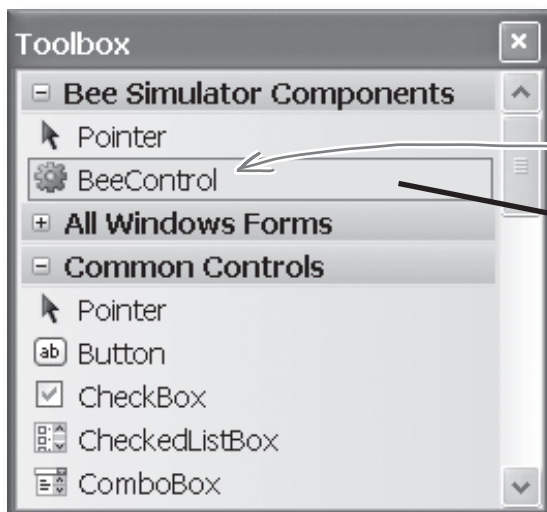

As long as we extend the right classes, .NET takes care of showing our control in the IDE toolbox.

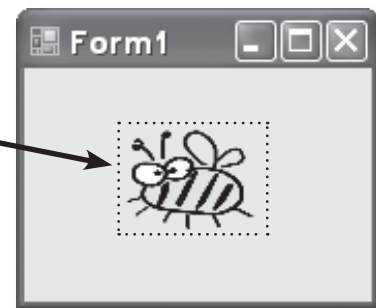

This is like a `PictureBox`, but the image is set, and there's animation that we'll build in. Any guesses as to what class `BeeControl` subclasses? *you are here* ▶

- 3 When you add images or other resources to the project's Resources file, you can access them using the `Properties.Resources` class. Just go to any line in your code and type `Properties.Resources.`—as soon as you do, the IntelliSense pops up a dropdown list that shows all of the pictures you've imported.

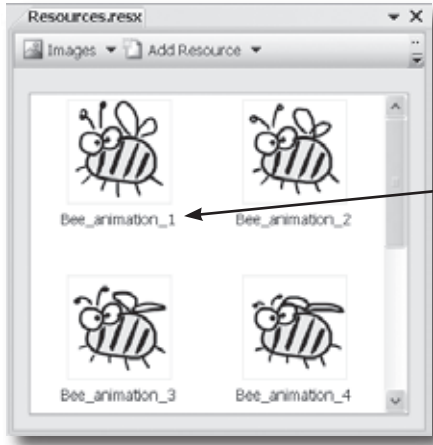

Note that "." at the end... that's what tells the IDE to pop up the properties and methods of the class you typed in.

`pictureBox1.Image = Properties.Resources.Bee_animation_1;`

This sets the image used for a particular PictureBox's image (and for our starting image).

These images are stored as public properties of the `Properties.Resources` class.

You'll need to add a "using `System.Windows.Forms`" line for the `PictureBox` and `Timer`.

- 4 Now add your **BeeControl**! Just add this `BeeControl` class to your project:

```
public class BeeControl : PictureBox {
    private Timer animationTimer = new Timer();
    public BeeControl() {
        animationTimer.Tick += new EventHandler(animationTimer_Tick);
        animationTimer.Interval = 150;
        animationTimer.Start();
        BackColor = System.Drawing.Color.Transparent;
        BackgroundImageLayout = ImageLayout.Stretch;
    }
}
```

```
private int cell = 0;
void animationTimer_Tick(object sender, EventArgs e) {
    cell++;
    switch (cell) {
        case 1: BackgroundImage = Properties.Resources.Bee_animation_1; break;
        case 2: BackgroundImage = Properties.Resources.Bee_animation_2; break;
        case 3: BackgroundImage = Properties.Resources.Bee_animation_3; break;
        case 4: BackgroundImage = Properties.Resources.Bee_animation_4; break;
        case 5: BackgroundImage = Properties.Resources.Bee_animation_3; break;
        default: BackgroundImage = Properties.Resources.Bee_animation_2;
                cell = 0; break;
    }
}
```

Each time the timer's tick event fires, it increments `cell`, and then does a switch based on it to assign the right picture to the `Image` property (inherited from `PictureBox`).

When you change the code for a control, you need to rebuild your program to make your changes show up in the designer.

Here's where you initialize the timer by instantiating it, setting its `Interval` property, and then adding its tick event handler.

Once we get back to frame #1, we'll reset `cell` back to 0.

Then **rebuild your program**. Go back to the form designer and look in the toolbox, the `BeeControl` is there. Drag it onto your form—you get an **animated** bee!

Create a button to add the BeeControl to your form

It's easy to add a control to a form—just add it to the Controls collection. And it's just as easy to remove from the form by removing it from Controls. But controls implement `IDisposable`, so make sure you **always dispose your control** after you remove it.

Now do this

- 1 **Remove the BeeControl from your form, and then add a button**
Go to the form designer and **delete the BeeControl from the form**. Then add a button. We'll make the button add and remove a BeeControl.

- 2 **Add a button to add and remove the bee control**

Here's the event handler for it:

```

BeeControl control = null;
private void button1_Click(object sender, EventArgs e) {
    if (control == null) {
        control = new BeeControl() { Location = new Point(100, 100) };
        Controls.Add(control);
    } else {
        Controls.Remove(control);
        control.Dispose();
        control = null;
    }
}
    
```

When you add a control to the Controls collection, it appears on the form immediately.

You can use an object initializer to set the BeeControl properties after it's instantiated.

All you need to do to remove the control is remove it from the Controls collection. But make sure you dispose it—otherwise it'll keep taking up resources!

Now when you run your program, if you click the button once it'll add a new BeeControl to the form. Click it again and it'll delete it. It uses the private `control` field to hold the reference to the control. (It sets the reference to null when there's no control on the form.)

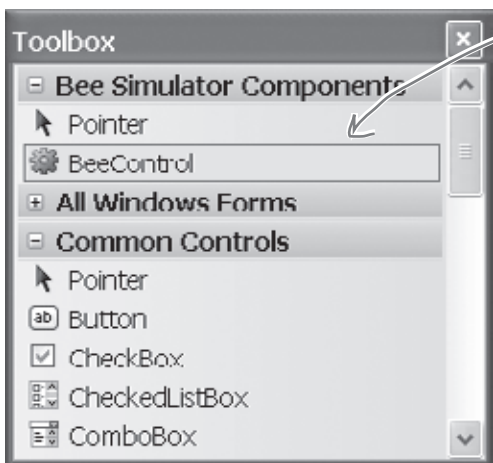

You can add your own control to the toolbox just by creating a class that inherits from `Control`.

Behind the Scenes



Every visual control in your toolbox inherits from `System.Windows.Forms.Control`. That class has members which should be pretty familiar by now: `Visible`, `Width`, `Height`, `Text`, `Location`, `BackColor`, `BackgroundImage`...all of those familiar properties you see in the Properties window for any control.

Your controls need to dispose their controls, too!

There's a problem with the BeeControl. Controls need to be disposed after they're done. But the BeeControl creates a new instance of Timer, which is a control that shows up in the toolbox... and it never gets disposed! That's a problem. Luckily, it's easy to fix—just override the `Dispose()` method.

← The control class implements `IDisposable`, so you need to make sure every control you use gets disposed.

3 Override the `Dispose()` method and dispose of the timer

Since `BeeControl` inherits from a control, then that control must have a `Dispose()` method. So we can just override and extend that method to dispose our timer. Just go into the control and type override:

```
public class BeeControl : PictureBox {
    override
```



← When you type "override" inside a class, the IDE pops up an IntelliSense window with all of the methods you can override. Select the `Dispose()` method and it'll fill one in for you!

As soon as you click on `Dispose()`, the IDE will fill in the method with a call to `base.Dispose()`:

```
protected override void Dispose(bool disposing) {
    base.Dispose(disposing);
}
```

3 Add the code to dispose the timer

Change the new `Dispose()` method that the IDE added for you so that it calls `animationTimer.Dispose()`.

```
protected override void Dispose(bool disposing) {
    animationTimer.Dispose();
    base.Dispose(disposing);
}
```

Now the `BeeControl` will dispose of its timer as part of its own `Dispose()` method. It cleans up after itself!

← Now your `BeeControl` will dispose of the timer that it created in its constructor. The IDE filled in a call to the `PictureBox` base class's `Dispose()` method—leave it in so the `PictureBox` can dispose itself, too.

Any control that you write from scratch is responsible for disposing any other controls (or disposable objects) that it creates.

A UserControl is an easy way to build a control

There's an easier way to build your own Toolbox controls. Instead of creating a class that inherits from an existing control, all you need to do is **use the IDE to add a UserControl to your project**. You work with a UserControl just like a form. You can drag other controls out of the toolbox and onto it—it uses the normal form designer in the IDE. And you can use its events just like you do with a form. So let's rebuild the BeeControl using a UserControl.



- 1 Right-click on BeeControl.cs in the IDE and rename it to OldBeeControl.cs. The IDE will **pop up a Yes/No window**: *“You are renaming a file. Would you also like to perform a rename in this project of all references to the code element ‘BeeControl?’”*—this window is asking if you want to rename the BeeControl class to OldBeeControl, and then change all of the code in the project to reflect this change. **Click the “Yes” button** to rename your BeeControl to OldBeeControl.
- 2 Right-click on the project in the Solution Explorer and select “Add >> User Control...” Have the IDE **add a user control called BeeControl**. The IDE will open up the new control in the form designer. *Use the animationTimer_Tick() method (you'll need to rename it) and the cell field from the old bee control—but don't copy anything else.*
- 3 Drag a Timer control onto your user control. It'll show up at the bottom of the designer, just like with a form. Use the Properties window to set its Interval to 150 and its Enabled to true. Then double-click on it—the IDE will add its Tick event handler. Just use the same Tick event handler that you used earlier to animate the first bee control.

- 4 Now update the BeeControl's constructor:

```
public BeeControl() {
    InitializeComponent();
    BackColor = System.Drawing.Color.Transparent;
    BackgroundImageLayout = ImageLayout.Stretch;
}
```

You can also do this from the Properties page in the IDE, instead of using code.

- 5 Go back to the button event handler on the form. When you renamed the first BeeControl to OldBeeControl, it changed the form code as well. So change the two lines back to BeeControl so it uses your new UserControl instead of the PictureBox:

```
BeeControl control = null;
private void button1_Click(...) {
    if (control == null) {
        control = new BeeControl() { ...

```

Now **run your program**—it should work exactly the same as before. The button now adds and removes your UserControl-based BeeControl.

A UserControl is an easy way to add a control to the toolbox. Edit a UserControl just like a form—you can drag other controls out of the toolbox onto it, and you can use its events exactly like a form's events.



But I've been using controls all this time, and I've never disposed a single one of them! Why should I start now?

You didn't dispose your controls because your forms did it for you.

But don't take our word for it. Use the IDE's search function to search your project for the word "Dispose", and you'll find that the IDE added a method in `Form1.Designer.cs` to override the `Dispose()` method that calls its own `base.Dispose()`. When the form is disposed, **it automatically disposes everything in its Controls collection** so you don't have to worry about it. But once you start removing controls from that collection or creating new instances of controls (like the `Timer` in the `BeeControl`) outside of the `Controls` collection, then you need to do the disposal yourself.

there are no Dumb Questions

Q: Why does the form code for the `PictureBox`-based `BeeControl` work exactly the same with the `UserControl`-based `BeeControl`?

A: Because the code doesn't care how the `BeeControl` object is implemented. It just cares that it can add the object to the form's `Controls` method.

Q: I double-clicked on my `OldBeeControl` class in the `Solution Explorer`, and it had a message about adding components to my class. What's that about?

A: When you create a control by adding a class to your project that inherits from `PictureBox` or another control, the IDE does some clever things. One of the things it does is let you work with **components**, those non-visual controls like `Timer` and

`OpenFileDialog` that show up in the space beneath your form when you work with them.

Give it a try—create an empty class that inherits from `PictureBox`. Then rebuild your project and double-click on it in the IDE. You'll get this message:

To add components to your class, drag them from the Toolbox and use the Properties window to set their properties.

Drag an `OpenFileDialog` out of the `Toolbox` and onto your new class. It'll appear as an icon. You can click on it and set its properties. Set a few of them. Now go back to the code for your class. Check out the constructor—the IDE added code to instantiate the `OpenFileDialog` object and set its properties.

Q: When I changed the properties in the `OpenFileDialog`, I noticed an error message in the IDE: "You must rebuild your project for the changes to show up in any open designers." Why did I get this error?

A: Because the designer runs your control, and until you rebuild your code it's not running the latest version of the control.

Remember how the wings of the bee were flapping when you first created your `BeeControl`, even when you dragged it out of the toolbox and into the designer? You weren't running your program yet, but the code that you wrote was being executed. The timer was firing its `Tick` event, and your event handler was changing the picture. The only way the IDE can make that happen is if the code were actually compiled and running in memory somewhere. So it's reminding you to update your code so it can display your controls properly.

The renderer uses your BeeControl to draw animated bees on your forms

With a BeeControl class and two forms, you just need a way to position bees, move them from one form to the other, and keep up with the bees. You'll also need to position flowers on the FieldForm, although since flowers don't move, that's pretty simple. All of this is code that we can put into a new class, `Renderer`. Here's what that class does:

You'll want the hive and field forms "linked" to the stats form—that does useful things like minimizing the hive and field forms when you minimize the stats form. You can do this by telling Windows that the stats form is their owner.

1 The stats form will be the parent of the hive and field forms

The first step in adding graphics to the Beehive Simulator will be adding two forms to the project. You'll add one called `HiveForm` (to show the inside of the hive) and one called `FieldForm` (which will show the field of flowers). Then you'll add lines to the main form's constructor to show its two child forms to tell Windows that the stats form is their **owner**:

```
public Form1() {  
    // other code in the Form1 constructor  
    hiveForm.Show(this);  
    fieldForm.Show(this);  
}
```

Every form object has a `Show()` method. If you want to set another form as its owner, just pass a reference to that form to `Show()`.

2 The renderer keeps a reference to the world and each child form

At the very top of the `Renderer` class you'll need a few important fields. The class has to know the location of each bee and flower, so it needs a reference to the `World`. And it'll need to add, move, and remove controls in the two forms, so it needs a reference to each of those forms:

```
public class Renderer {  
    private World world;  
    private HiveForm hiveForm;  
    private FieldForm fieldForm;  
}
```

Start your `Renderer` class with these lines. We'll add to this class throughout the chapter.

3 The renderer uses dictionaries to keep track of the controls

`World` keeps track of its `Bee` objects using a `List<Bee>` and a `List<Flower>` to store its flowers. The renderer needs to be able to look at each of those `Bee` and `Flower` objects and figure out what `BeeControl` and `PictureBox` they correspond to—or, if it can't find a corresponding control, it needs to create one. So here's a perfect opportunity to use dictionaries. So we'll need two more private fields in `Renderer`:

```
private Dictionary<Flower, PictureBox> flowerLookup =  
    new Dictionary<Flower, PictureBox>();  
private Dictionary<Bee, BeeControl> beeLookup =  
    new Dictionary<Bee, BeeControl>();
```

These dictionaries become one-to-one mappings between a bee or flower and the control for that bee or flower.

These two dictionary collections let the renderer store exactly one control for each bee or flower in the world.

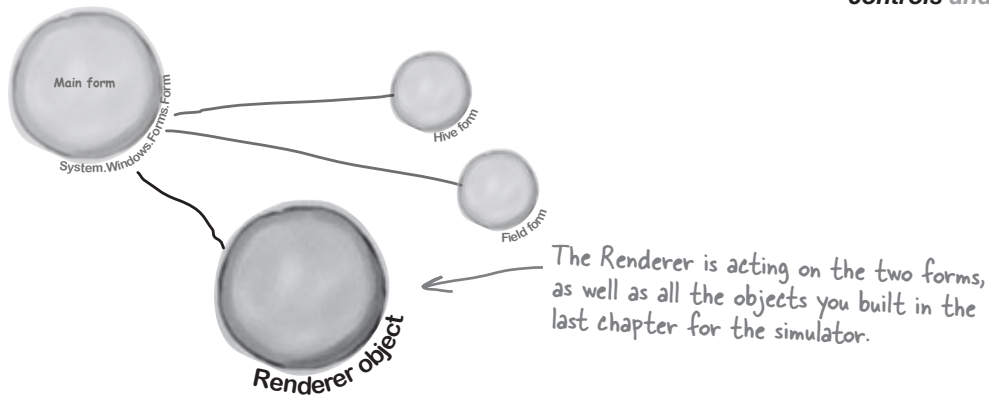

4 The bees and flowers already know their locations

There's a reason we stored each bee and flower location using a `Point`. Once we have a `Bee` object, we can easily look up its `BeeControl` and set its location.

```
beeControl = beeLookup[bee];
beeControl.Location = bee.Location;
```

For each bee or flower, we can look up the matching control. Then, set that control's location to match the location of the bee or flower object.

5 If a bee doesn't have a control, the renderer adds it to the hive form

It's easy enough for the renderer to figure out if a particular bee or flower has a control. If the dictionary's `ContainsKey()` method returns `false` for a particular `Bee` object, that means there's no control on the form for that bee. So `Renderer` needs to create a `BeeControl`, add it to the dictionary, and then add the control to the form. (It also calls the control's `BringToFront()` method, to make sure the control doesn't get hidden behind the flower `PictureBox`s):

```
if (!beeLookup.ContainsKey(bee)) {
    beeControl = new BeeControl() { Width = 40, Height = 40 };
    beeLookup.Add(bee, beeControl);
    hiveForm.Controls.Add(beeControl);
    beeControl.BringToFront();
} else
    beeControl = beeLookup[bee];
```

`ContainsKey()` tells us if the bee exists in the dictionary. If not, then we need to add that bee, along with a corresponding control.

`BringToFront()` ensures the bee appears "on top of" any flowers on the `FieldForm`, and on top of the background of the `HiveForm`.

Remember how a dictionary can use anything as a key? Well, this one uses a `Bee` object as a key. The renderer needs to know which `BeeControl` on the form belongs to a particular bee. So it looks up that bee's object in the dictionary, which spits out the correct control. Now the renderer can move it around.

Add the hive and field forms to the project

Now you need forms to put bees on. So **start with your existing Beehive Simulator project**, and use “Add >> Existing Item...” to **add your new BeeControl user control**. The UserControl has a .cs file, a .designer.cs file and a .resx file—you’ll need to add all three. Then open up the code for both the .cs and .designer.cs files, and change the namespace lines so they match the namespace of your new project. Rebuild your project; the BeeControl should now show up in the toolbox. You’ll also need to add the graphics to the new project’s resources. Then add two more Windows forms to the project by **right-clicking on the project** in the Solution Explorer and choosing “Windows Form...” from the Add menu. If you name the files HiveForm.cs and FieldForm.cs, the IDE will automatically set their Name properties to `HiveForm` and `FieldForm`. You already know that forms are just objects, so `HiveForm` and `FieldForm` are really just two more classes.

This is a PictureBox control with its `BackgroundImage` set to the outside hive picture. When you load the hive pictures into the Resource Designer, they’ll show up in the list of resources when you click the “...” button next to `BackgroundImage` in the Properties window.



Make sure you resize both forms so they look like these screenshots.

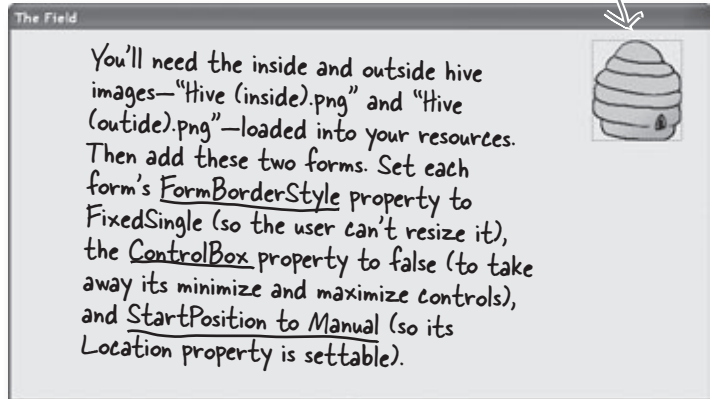

Set the form's `BackgroundImage` property to the inside hive picture, and its `BackgroundImageLayout` property to `Stretch`.

Figure out where your locations are

You need to figure out where the hive is on your `FieldForm`. Using the Properties window, create a handler for the `MouseClicked` event, and add this code:

```
private void FieldForm_MouseClick(object sender, MouseEventArgs e)
{
    MessageBox.Show(e.Location.ToString());
}
```

Once you've added the `MouseClicked` event handler to the form, you can run the program. Once it's running, click on the exit of the hive in the picture. The event handler will pop up a message box that shows you the exact coordinates of the spot that you clicked!

Add the same handler to `HiveForm`, and run it. Then, by clicking, get the coordinates of the exit, the nursery, and the honey factory. Using all these locations, you can update the `InitializeLocations()` method you wrote in the `Hive` class in the last chapter:

```
private void InitializeLocations()
{
    locations = new Dictionary<string, Point>();
    locations.Add("Entrance", new Point(600, 100));
    locations.Add("Nursery", new Point(95, 174));
    locations.Add("HoneyFactory", new Point(157, 98));
    locations.Add("Exit", new Point(194, 213));
}
```

Remember, go to the Properties window, click on the lightning-bolt icon to bring up the Events window, scroll down to the `MouseClicked` row and double-click on it. The IDE will add the event handler for you.

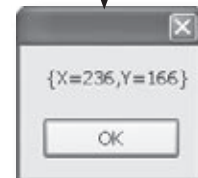

Remove the mouse click handler when you're done... you just needed it to get the locations on your forms.

Build the Renderer

Here's the complete `Renderer` class. The main form calls this class's `Render()` method right after it calls `World.Go()` to draw the bees and flowers on the forms. You'll need to make sure that the flower graphic (`Flower.png`) is loaded into the project, just like the animated bee images.

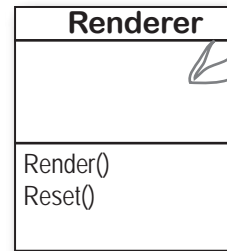

All fields in the `renderer` are private because no other class needs to update any of its properties. It's fully encapsulated. The world just calls `Render()` to draw the world to the forms, and `Reset()` to clear the controls on the forms if it needs to reset.

```
public class Renderer {
    private World world;
    private HiveForm hiveForm;
    private FieldForm fieldForm;

    private Dictionary<Flower, PictureBox> flowerLookup =
        new Dictionary<Flower, PictureBox>();
    private List<Flower> deadFlowers = new List<Flower>();

    private Dictionary<Bee, BeeControl> beeLookup =
        new Dictionary<Bee, BeeControl>();
    private List<Bee> retiredBees = new List<Bee>();

    public Renderer(World world, HiveForm hiveForm, FieldForm fieldForm) {
        this.world = world;
        this.hiveForm = hiveForm;
        this.fieldForm = fieldForm;
    }

    public void Render() {
        DrawBees();
        DrawFlowers();
        RemoveRetiredBeesAndDeadFlowers();
    }

    public void Reset() {
        foreach (PictureBox flower in flowerLookup.Values) {
            fieldForm.Controls.Remove(flower);
            flower.Dispose();
        }
        foreach (BeeControl bee in beeLookup.Values) {
            hiveForm.Controls.Remove(bee);
            fieldForm.Controls.Remove(bee);
            bee.Dispose();
        }
        flowerLookup.Clear();
        beeLookup.Clear();
    }
}
```

The `renderer` keeps references to the world and the two forms it draws the bees on.

The world uses `Bee` and `Flower` objects to keep track of every bee and flower in the world. The forms use a `PictureBox` to display each flower and a `BeeControl` to display each bee. The `renderer` uses these dictionaries to connect each bee and flower to its own `BeeControl` or `PictureBox`.

When a flower dies or a bee retires, it uses the `deadFlowers` and `retiredBees` lists to clean out the dictionaries.

The timer on the main form that runs the animation calls the `Render()` method, which updates the bees and the flowers, and then cleans out its dictionaries.

If the simulator is reset, it calls each form's `Controls.Remove()` method to completely clear out the controls on the two forms. It finds all of the controls in each of its two dictionaries and removes them from the forms, calling `Dispose()` on each of them. Then it clears the two dictionaries.

here's the *renderer class*

It takes two foreach loops to draw the flowers. The first looks for new flowers and adds their PictureBoxes. The second looks for dead flowers and removes their PictureBoxes.

```
private void DrawFlowers() {
    foreach (Flower flower in world.Flowers)
        if (!flowerLookup.ContainsKey(flower)) {
            PictureBox flowerControl = new PictureBox() {
                Width = 45,
                Height = 55,
                Image = Properties.Resources.Flower,
                SizeMode = PictureBoxSizeMode.StretchImage,
                Location = flower.Location
            };
            flowerLookup.Add(flower, flowerControl);
            fieldForm.Controls.Add(flowerControl);
        }

    foreach (Flower flower in flowerLookup.Keys) {
        if (!world.Flowers.Contains(flower)) {
            PictureBox flowerControlToRemove = flowerLookup[flower];
            fieldForm.Controls.Remove(flowerControlToRemove);
            flowerControlToRemove.Dispose();
            deadFlowers.Add(flower);
        }
    }
}
```

DrawFlowers() uses the Location property in the Flower object to set the PictureBox's location on the form.

The first foreach loop uses the flowerLookup dictionary to check each flower to see if it's got a control on the form. If it doesn't, it creates a new PictureBox using an object initializer, adds it to the form, and then adds it to the flowerLookup dictionary.

The second foreach loop looks for any PictureBox in the flowerLookup dictionary that's no longer on the form and removes it.

After it removes the PictureBox, it calls its Dispose() method. Then it adds the Flower object to deadFlowers so it'll get cleared later.

```
private void DrawBees() {
    BeeControl beeControl;
    foreach (Bee bee in world.Bees) {
        beeControl = GetBeeControl(bee);
        if (bee.InsideHive) {
            if (fieldForm.Controls.Contains(beeControl))
                MoveBeeFromFieldToHive(beeControl);
        } else if (hiveForm.Controls.Contains(beeControl))
            MoveBeeFromHiveToField(beeControl, bee);
        beeControl.Location = bee.Location;
    }

    foreach (Bee bee in beeLookup.Keys) {
        if (!world.Bees.Contains(bee)) {
            beeControl = beeLookup[bee];
            if (fieldForm.Controls.Contains(beeControl))
                fieldForm.Controls.Remove(beeControl);
            if (hiveForm.Controls.Contains(beeControl))
                hiveForm.Controls.Remove(beeControl);
            beeControl.Dispose();
            retiredBees.Add(bee);
        }
    }
}
```

Once the BeeControl is removed, we need to call its Dispose() method—the user control will dispose of its timer for us.

DrawBees() also uses two foreach loops, and it does the same basic things as DrawFlowers(). But it's a little more complex, so we split some of its behavior out into separate methods to make it easier to understand.

DrawBees() checks if a bee is in the hive but its control is on the FieldForm, or vice versa. It uses two extra methods to move the BeeControls between the forms.

The second foreach loop works just like in DrawFlowers(), except it needs to remove the BeeControl from the right form.

You'll need to make sure you've got using System.Drawing and using System.Windows.Forms at the top of the Renderer class file.

```
private BeeControl GetBeeControl(Bee bee) {
    BeeControl beeControl;
    if (!beeLookup.ContainsKey(bee)) {
        beeControl = new BeeControl() { Width = 40, Height = 40 };
        beeLookup.Add(bee, beeControl);
        hiveForm.Controls.Add(beeControl);
        beeControl.BringToFront();
    }
    else
        beeControl = beeLookup[bee];
    return beeControl;
}
```

Don't forget that the ! means NOT.

GetBeeControl() looks up a bee in the beeLookup dictionary and returns it. If it's not there, it creates a new 40 x 40 BeeControl and adds it to the hive form (since that's where bees are born).

MoveBeeFromHiveToField() takes a specific BeeControl out of the hive form's Controls collection and adds it to the field form's Controls collection.

```
private void MoveBeeFromHiveToField(BeeControl beeControl) {
    hiveForm.Controls.Remove(beeControl);
    beeControl.Size = new Size(20, 20);
    fieldForm.Controls.Add(beeControl);
    beeControl.BringToFront();
}
```

The bees on the field form are smaller than the ones on the hive form, so the method needs to change BeeControl's Size property.

```
private void MoveBeeFromFieldToHive(BeeControl beeControl) {
    fieldForm.Controls.Remove(beeControl);
    beeControl.Size = new Size(40, 40);
    hiveForm.Controls.Add(beeControl);
    beeControl.BringToFront();
}
```

MoveBeeFromFieldToHive() moves a BeeControl back to the hive form. It has to make it bigger again.

```
private void RemoveRetiredBeesAndDeadFlowers() {
    foreach (Bee bee in retiredBees)
        beeLookup.Remove(bee);
    retiredBees.Clear();
    foreach (Flower flower in deadFlowers)
        flowerLookup.Remove(flower);
    deadFlowers.Clear();
}
```

Whenever DrawBees() and DrawFlowers() found that a flower or bee was no longer in the world, it added them to the deadFlowers and retiredBees lists to be removed at the end of the frame.

After all the controls are moved around, the renderer calls this method to clear any dead flowers and retired bees out of the two dictionaries.

Now connect the main form to your two new forms, HiveForm and FieldForm

It's great to have a Renderer, but so far, there aren't any forms to render onto. We can fix that by going back to the main Form class (probably called Form1), and making some code changes:

```
public partial class Form1 : Form {
    HiveForm hiveForm = new HiveForm();
    FieldForm fieldForm = new FieldForm();
    Renderer renderer;
```

When the main form loads, it creates an instance of each of the other two forms. They're just objects in the heap for now—they won't be displayed until their Show() methods are called.

```
// the rest of the fields
```

```
public Form1() {
    InitializeComponent();
```

Move the code to instantiate the World into the ResetSimulator() method.

```
    MoveChildForms();
    hiveForm.Show(this);
    fieldForm.Show(this);
    ResetSimulator();
```

The form passes a reference to itself into Form.Show() so it becomes the parent form.

The main form's constructor moves the two child forms in place, then displays them. Then it calls ResetSimulator(), which instantiates Renderer.

```
    // The rest of the code stays the same
```

Everything else that used to be in the constructor will be moved to the ResetSimulator() method.

```
private void MoveChildForms() {
    hiveForm.Location = new Point(Location.X + Width + 10, Location.Y);
    fieldForm.Location = new Point(Location.X,
        Location.Y + Math.Max(Height, hiveForm.Height) + 10);
}
```

This code moves the two forms so that the hive form is next to the main stats form and the field form is below both of them.

```
public void RunFrame(object sender, EventArgs e) {
    framesRun++;
    world.Go(random);
    renderer.Render();
    // previous code
}
```

Adding this one line to RunFrame makes the simulator update the graphics after each time the world's Go() method is called.

```
private void Form1_Move(object sender, EventArgs e) {
    MoveChildForms();
}
```

Use the Events button in the Properties window to add the Move event-handler.

The Move event is fired every time the main form is moved. Calling MoveChildForms() makes sure the child forms always move along with the main form.

Make sure you've set the field and hive forms' StartPosition property to Manual, or else MoveChildForms() won't work.

Here's where we create new instances of the World and Renderer classes, which resets the simulator.

```
private void ResetSimulator() {
    framesRun = 0;
    world = new World(new Bee.BeeMessage(SendMessage));
    renderer = new Renderer(world, hiveForm, fieldForm);
}

private void reset_Click(object sender, EventArgs e) {
    renderer.Reset();
    ResetSimulator();
    if (!timer1.Enabled)
        toolStrip1.Items[0].Text = "Start simulation";
}

private void openToolStripButton_Click(object sender, EventArgs e) {
    // The rest of the code in this button stays exactly the same.

    renderer.Reset();
    renderer = new Renderer(world, hiveForm, fieldForm);
}
}
```

The Reset button needs to call Reset() to clear out all the BeeControls and flower PictureBoxes, and then reset the simulator.

Finally, you'll need to add code to the Open button on the ToolStrip to use the Reset() method to remove the bees and flowers from the two forms' Controls collections, and then create a new renderer using the newly loaded world.

there are no Dumb Questions

Q: I saw that you showed the form using a Show() method, but I don't quite get what was going on with passing this as a parameter.

A: This all comes down to the idea that a form is just another class. When you display a form you're just instantiating that class and calling its Show() method. There's an overloaded version of Show() that takes one parameter, a parent window. When one form is a parent of another, it causes Windows to set up a special relationship between them—for example, when you minimize the parent window, it automatically minimizes all of that form's child windows, too.

Q: Can you alter the preexisting controls and muck around with their code?

A: No, you can't actually access the code inside the controls that ship with Visual Studio. However, every single one of those controls is a class that you can inherit, just like you inherited from PictureBox to create your BeeControl. If you want to add or change behavior in any of those controls, you add your own methods and properties that manipulate the ones in the base class.

Test drive... ahem... buzz

Compile all your code, chase down any errors you're getting, and run your simulator.

Your bees should be happily flapping their wings now.

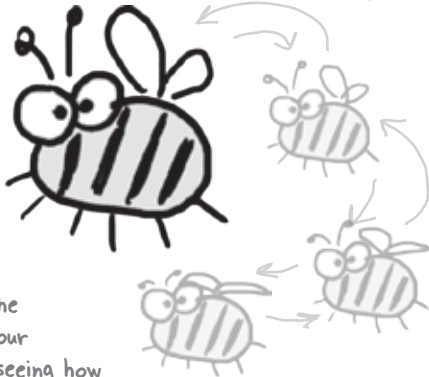

Try changing the constants on your simulator, and seeing how the Renderer handles more bees or flowers.

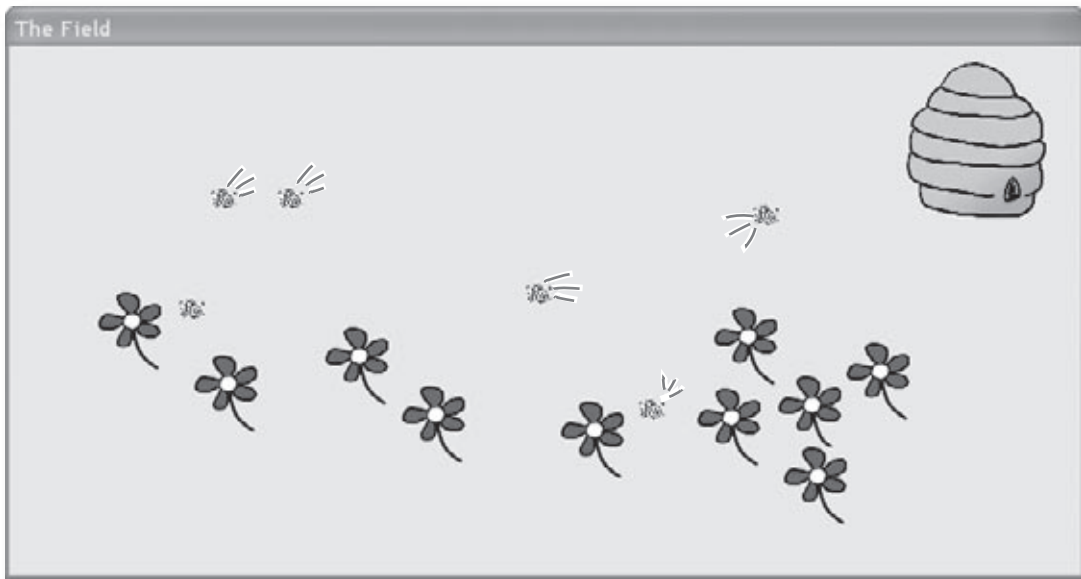
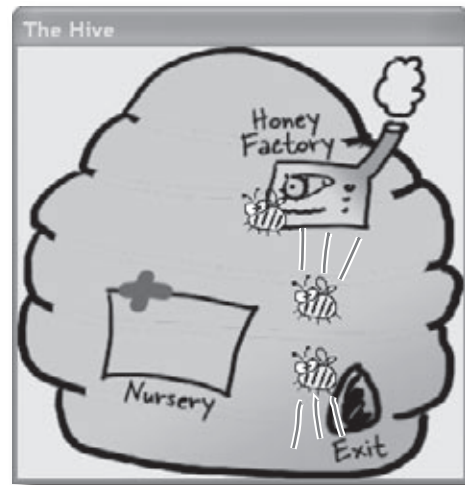

Looks great, but something's not quite right...

Look closely at the bees buzzing around the hive and the flowers, and you'll notice some problems with the way they're being rendered. Remember how you set each BeeControl's `BackColor` property to `Color.Transparent`? Unfortunately, that wasn't enough to keep the simulator from having some problems which are actually pretty typical of graphics programs.

1 There are some serious performance issues

Did you notice how the whole simulator slows down when all the bees are inside the hive? If not, try adding more bees by increasing the constants in the `Hive` class. Keep your eye on the frame rate—add more bees, and it starts to drop significantly.

2 The flowers' backgrounds aren't really transparent

And there's another, completely *separate* problem. When we saved the graphics files for the flowers, we gave them transparent backgrounds. But while that made sure that each flower's background matched the background of the form, it doesn't look so nice when flowers overlap each other.

When you set a `PictureBox`'s background color to `Transparent`, it draws any transparent pixels in the image so they match the background of the form... which isn't always the right thing to do.

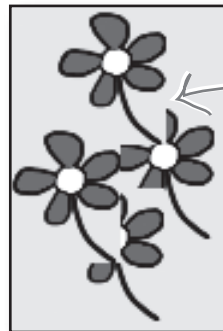

When one `PictureBox` overlaps another, C# draws the transparent pixels so they match the form, not the other control that it overlaps, causing weird rectangular "cut-outs" any time two flowers overlap.

3 The bees' backgrounds aren't transparent, either

It turns out that `Color.Transparent` really does have some limitations. When the bees are hovering over the flowers, the same "cut-out" glitch happens. Transparency works a little better with the hive form, where the form's background image does show through the transparent areas of the bee graphics. But when the bees overlap, the same problems occur. And if you watch closely as the bees move around the hive, you'll see some glitches where the bee images are sometimes distorted when they move.

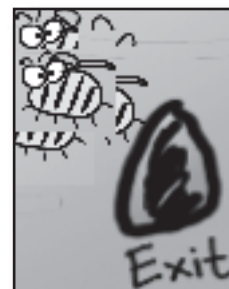

Let's take a closer look at those performance issues

Each bee picture you downloaded is big. Really big. Pop one of them open in Windows Picture Viewer and see for yourself. That means the PictureBox needs to shrink it down every time it changes the image, and scaling an image up or down takes time. The reason the bees move a lot slower when there's a lot of them flying around inside the hive is because the inside hive picture is HUGE. And when you made the background for the BeeControl transparent, it needs to do double work: first it has to shrink the bee picture down, and then it needs to shrink a portion of the form's background down so that it can draw it in the transparent area behind the bee.

Bee animation 1.png



The bee picture is really big, and the PictureBox needs time to shrink it down every time it displays a new animation frame.

The graphics files for the bees are really BIG. When the PictureBox needs to scale the picture down to size every time it displays a new animation frame. That takes a lot of time...

The inside hive picture is huge. Every time a bee flies in front of it, its PictureBox needs to scale it down to the size of the control. It needs to do that to show part of the picture any place the bee picture's transparent background lets it show through.

Hive (Inside).png

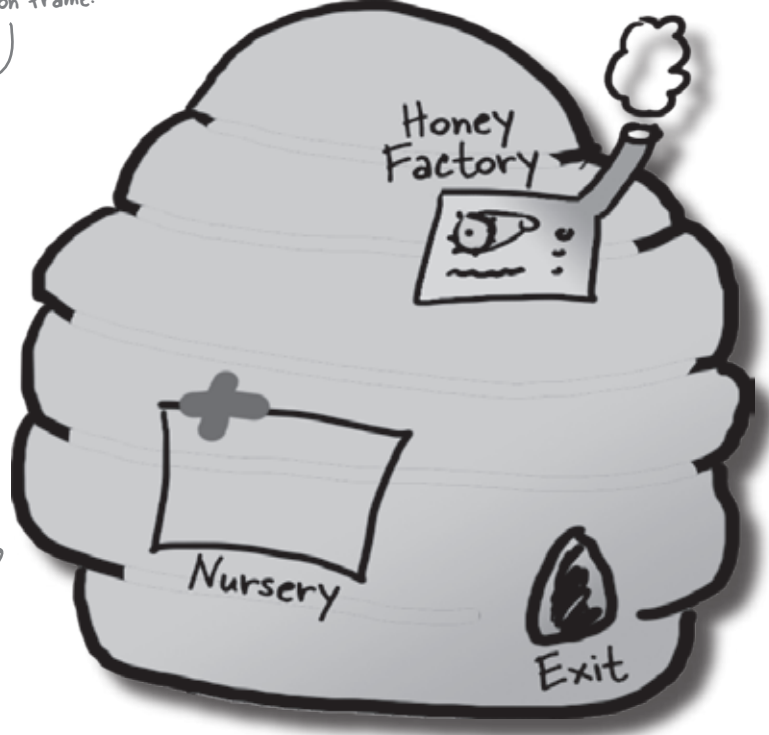

...so all we need to do to speed up the simulator's performance is to shrink down all the pictures *before* we try to display them.

All we need to do to speed up the graphics performance is add a method to the renderer that scales any image to a different size. Then we can **resize each picture once when it's loaded**, and only use the scaled down version in the bee control and for the hive form's background.



1 Add the `ResizeImage` method to the renderer

All of the pictures in your project (like `Properties.Resources.Flower`) are stored as `Bitmap` objects. Here's a static method that resizes bitmaps—add it to the `Renderer` class:

```
public static Bitmap ResizeImage(Bitmap picture, int width, int height) {
    Bitmap resizedPicture = new Bitmap(width, height);
    using (Graphics graphics = Graphics.FromImage(resizedPicture)) {
        graphics.DrawImage(picture, 0, 0, width, height);
    }
    return resizedPicture;
}
```

We'll take a closer look at what this `Graphics` object is and how this method works in the next few pages

2 Add this `ResizeCells` method to your `BeeControl`

Your `BeeControl` can store its own `Bitmap` objects—in this case, an array of four of them. Here's a control that'll populate that array, resizing each one so that it's exactly the right size for the control:

```
private Bitmap[] cells = new Bitmap[4];
private void ResizeCells() {
    cells[0] = Renderer.ResizeImage(Properties.Resources.Bee_animation_1, Width, Height);
    cells[1] = Renderer.ResizeImage(Properties.Resources.Bee_animation_2, Width, Height);
    cells[2] = Renderer.ResizeImage(Properties.Resources.Bee_animation_3, Width, Height);
    cells[3] = Renderer.ResizeImage(Properties.Resources.Bee_animation_4, Width, Height);
}
```

These lines take each of the `Bitmap` objects that store the bee pictures and shrink them down using the `ResizeImage()` method we wrote.

3 Change the switch statement so that it uses the `cells` array, not the resources

The `BeeControl`'s Tick event handler has a switch statement that sets its `BackgroundImage`:

```
BackgroundImage = Properties.Resources.Bee_animation_1;
```

Replace `Properties.Resources.Bee_animation_1` with `cells[0]`. Now replace the rest of the **case** lines, so that case 2 one uses `cells[1]`, case 3 uses `cells[2]`, case 4 uses `cells[3]`, case 5 uses `cells[2]`, and the default case uses `cells[1]`. That way only the resized image is displayed.

4 Add calls to `ResizeCells()` to the `BeeControl`

You'll need to add two calls to the new `ResizeCells()` method. First, **add it** to the bottom of the constructor. Then go back to the IDE designer by double-clicking on the `BeeControl` in the Properties window. Go over to the Events page in the Properties window (by clicking on the lightning bolt icon), scroll down to `Resize`, and double-click on it to **add a Resize event handler**. Make the new `Resize` event handler call `ResizeCells()` too—that way it'll resize its animation pictures every time the form is resized.

5 Set the form's background image manually

Go to the Properties window and set the hive form's background image to (none). Then go to its constructor and set the image to one that's sized properly.

```
public partial class HiveForm : Form {
    public HiveForm() {
        InitializeComponent();
        BackgroundImage = Renderer.ResizeImage(
            Properties.Resources.Hive_inside,
            ClientRectangle.Width, ClientRectangle.Height);
    }
}
```

Your form has a `ClientRectangle` property that contains a `Rectangle` which has the dimensions of its display area.

Now run the simulator—it's much faster!

You resized your Bitmaps using a Graphics object

Forms and controls have a `CreateGraphics()` method that returns a new `Graphics` object. You'll see a lot more about that shortly.

Let's take a closer look at that `ResizeImage()` method you added to the renderer. The first thing it does is create a new `Bitmap` object that's the size that the picture will be resized to. Then it uses `Graphics.FromImage()` to **create a new Graphics object**. It uses that `Graphics` object's `DrawImage()` method to draw the picture onto the `Bitmap`. Notice how you passed the width and height parameters to `DrawImage()`—that's how you tell it to scale the image down to the new size. Finally you returned the new `Bitmap` you created, so it can be used as the form's background image or one of the four animation cells.

You pass a picture into the method, along with a new width and height that it'll be resized to.

```
public static Bitmap ResizeImage(Bitmap picture, int width, int height) {
    Bitmap resizedPicture = new Bitmap(width, height);
    using (Graphics graphics = Graphics.FromImage(resizedPicture)) {
        graphics.DrawImage(picture, 0, 0, width, height);
    }
    return resizedPicture;
}
```

The `FromImage()` method returns a new `Graphics` object that lets you draw graphics onto that image. Take a minute and use the IDE's IntelliSense to look at the methods in the `Graphics` class. When you call `DrawImage()`, it copies the image into the `resizedPicture` bitmap at the location `(0, 0)` and scaled to the width and height parameters..

Let's see image resizing in action

Drag a button onto the Field form and add this code. It creates a new `PictureBox` control that's 100 x 100 pixels, setting its border to a black line so you can see how big it is. Then it uses `ResizeImage()` to make a bee picture that's squished down to 80 x 40 pixels and assigns that new picture to its `Image` property. Once the `PictureBox` is added to the form, the bee is displayed.

Just do this temporarily. Delete the button and code when you're done.

```
private void button1_Click(object sender, EventArgs e)
{
    PictureBox beePicture = new PictureBox();
    beePicture.Location = new Point(10, 10);
    beePicture.Size = new Size(100, 100);
    beePicture.BorderStyle = BorderStyle.FixedSingle;
    beePicture.Image = Renderer.ResizeImage(
        Properties.Resources.Bee_animation_1, 80, 40);
    Controls.Add(beePicture);
}
```

You can see the image resizing in action—the squished bee image is much smaller than the `PictureBox`. `ResizeImage()` squished it down.

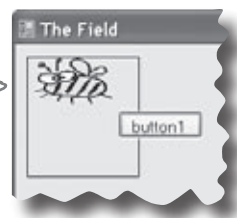

The `ResizeImage()` method creates a `Graphics` object to draw on an invisible `Bitmap` object. It returns that `Bitmap` so it can be displayed on a form or in `PictureBox`.

Your image resources are stored in Bitmap objects

When you import graphics files into your project's resources, what happens to them? You already know that you can access them using `Properties.Resources`. But what, exactly, is your program doing with them once they're imported?

.NET turns your image into a new **Bitmap** object:

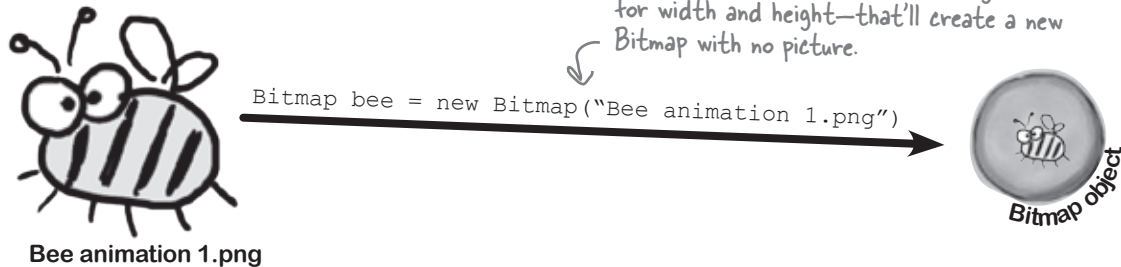

Then each Bitmap is drawn to the screen

Once your images are in `Bitmap` objects, your form draws them to the screen, with a call like this:

```
using (Graphics g = CreateGraphics()) {
    g.DrawImage(myBitmap, 30, 30, 150, 150);
}
```

DrawImage() takes a Bitmap, the image to draw...

...a starting X, Y coordinate...

...and a size, 150x150 pixels.

This call gets a Graphics object to draw on the form. We use a using statement to make sure the Graphics object is disposed.

The bigger they are...

Did you notice those last two parameters to `DrawImage()`? What if the image in the `Bitmap` is 175 by 175? The graphics library must then resize the image to fit 150 by 150. What if the `Bitmap` contains an image that's 1,500 by 2,025? Then the scaling becomes even slower...

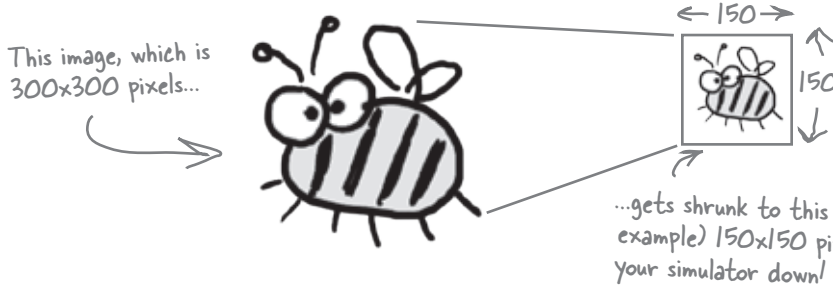

Resizing images takes a lot of processing power! If you do it once, it's no big deal. But if you do it EVERY FRAME, your program will slow down. We gave you REALLY BIG images for the bees and the hive. When the renderer moves the bees around (especially in front of the inside hive picture), it has to resize them over and over again. And that was causing the performance problems!

Use System.Drawing to TAKE CONTROL of graphics yourself

The Graphics object is part of the System.Drawing namespace. The .NET Framework comes with some pretty powerful graphics tools that go a lot further than the simple PictureBox control that's in the toolbox. You can draw shapes, use fonts, and do all sorts of complex graphics... and it all starts with a Graphics object. Any time you want to add or modify any object's graphics or images, you'll create a Graphics object that's **linked to the object you want to draw on**, and then use the Graphics object's methods to draw on your target.

System.Drawing
The graphics methods in the System.Drawing namespace are sometimes referred to as GDI+, which stands for Graphics Device Interface. When you draw graphics with GDI+, you start with a Graphics object that's hooked up to a Bitmap, form, control, or another object that you want to draw on using the Graphics object's methods.

- 1 Start with the object you want to draw on**
For instance, think about a form. When you call the form's `CreateGraphics()` method, it returns an instance of `Graphics` that's set up to draw on itself.

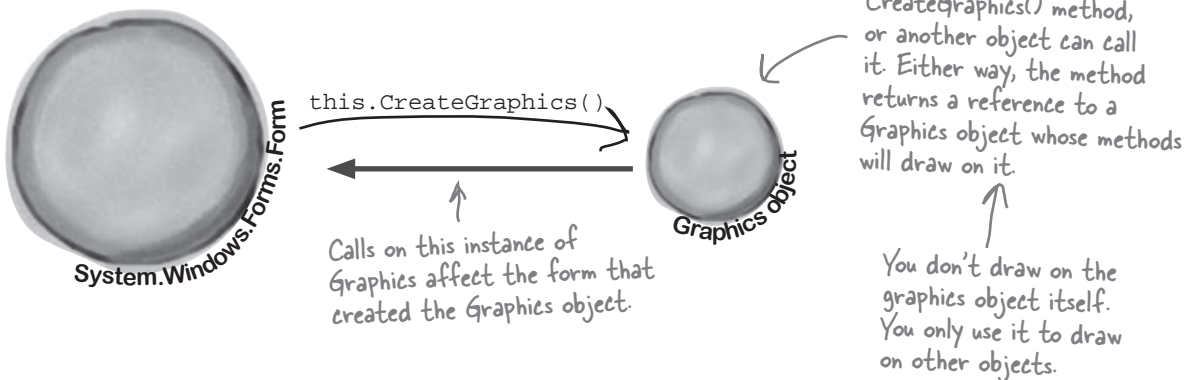

- 2 Use the Graphics object's methods to draw on your object**
Every `Graphics` object has methods that let you draw on the object that created it. When you call methods in the `Graphics` object to draw lines, circles, rectangles, text, and images, they appear on the form.

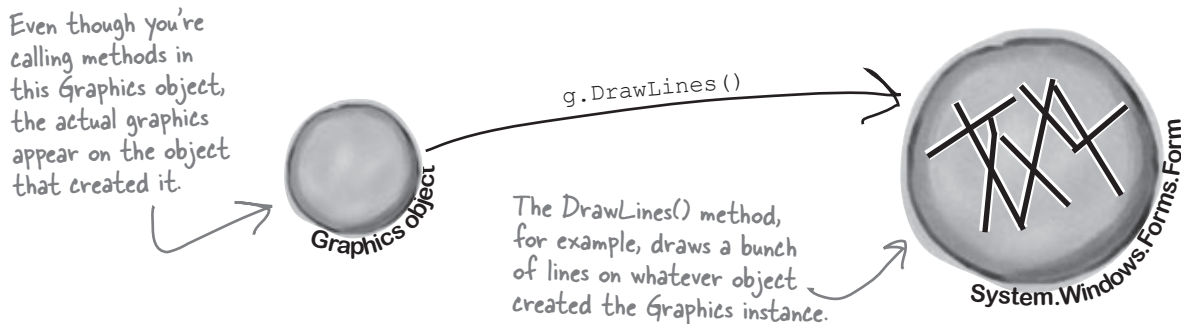

A 30-second tour of GDI+ graphics

There are all sorts of shapes and pictures that you can draw once you've created a `Graphics` object. All you need to do is call its methods, and it'll draw directly onto the object that created it.

You'll need to make sure you've got a using `System.Drawing`; line at the top of your class to use these methods. Or, when you add a form to your project, the IDE adds that line to your form class automatically.

- 1 The first step is always to grab yourself a `Graphics` object. Use a form's `CreateGraphics()` method, or have a `Graphics` object passed in. Remember, `Graphics` implements the `IDisposable()` interface, so if you create a new one use a `using` statement:

```
using (Graphics g = this.CreateGraphics()) {
```

Remember, this draws on the object that created this instance.

- 2 If you want to draw a line, call `DrawLine()` with starting point and ending point, each represented by X and Y coordinates:

```
g.DrawLine(Pens.Blue, 30, 10, 100, 45);
```

The start coordinate...

...and the end coordinate.

or you can do it using a couple of `Points`:

```
g.DrawLine(Pens.Blue, new Point(30, 45), new Point(100, 10));
```

- 3 Here's code that draws a filled slate gray rectangle, and then gives it a sky blue border. It uses a `Rectangle` to define the dimensions—in this case, the upper left hand corner is at (150, 15), and it's 140 pixels wide and 90 pixels high.

```
g.FillRectangle(Brushes.SlateGray, new Rectangle(150, 15, 140, 90));
g.DrawRectangle(Pens.SkyBlue, new Rectangle(150, 15, 140, 90));
```

There are a whole lot of colors you can use—just type "Color", "Pens" or "Brushes" followed by a dot and the IntelliSense window will display them.

- 4 You can draw an ellipse or a circle using the `DrawCircle()` or `FillCircle()` methods, which also use a `Rectangle` to specify how big the shape should be. This code draws two ellipses that are slightly offset to give a shadow effect:

```
g.FillEllipse(Brushes.DarkGray, new Rectangle(45, 65, 200, 100));
g.FillEllipse(Brushes.Silver, new Rectangle(40, 60, 200, 100));
```

- 5 Use the `DrawString()` method to draw text in any font and color. To do that, you'll need to create a `Font` object. It implements `IDisposable`, so use a `using` statement:

```
using (Font arial24Bold = new Font("Arial", 24, FontStyle.Bold)) {
    g.DrawString("Hi there!", arial24Bold, Brushes.Red, 50, 75);
}
```

If the above statements are executed in order, this is what will end up on the form. Each of the statements above matches up with the numbers here. The upper left-hand corner is coordinate (0, 0).

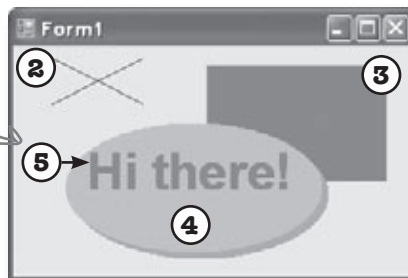

There's no step 1 on this picture, since that was creating the actual `Graphics` object.

Use graphics to draw a picture on a form

Let's create a new Windows application that draws a picture on a form **when you click on it**.

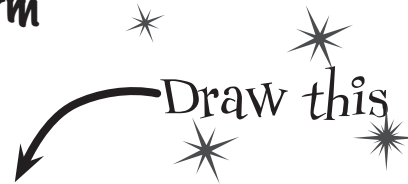

1 Start by adding a Click event to the form

Go to the **Events page in the Properties window** (by clicking on the lightning-bolt icon), scroll down to the Click event and double-click on it.

Start the event handler with a `using` line to create the Graphics object. When you work with GDI+, you use a lot of objects that implement `IDisposable`. If you don't dispose of them, they'll slowly suck up your computer's resources until you quit the program. So you'll end up using a lot of `using` statements:

```
using (Graphics g = CreateGraphics()) {
```

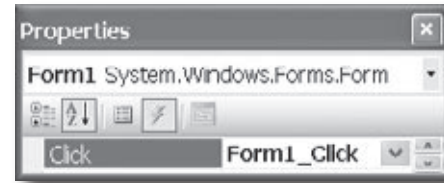

Here's the first line in your `Form1_Click()` event handler method. We'll give you all the lines for the event handler—put them together to draw the picture.

2 Pay attention to the order you draw things on our form

We want a sky blue background for this picture, so you'll draw a big blue rectangle first—then anything else you draw afterwards will be drawn **on top of it**. You'll take advantage of one of the form's properties called `ClientRectangle`. It's a `Rectangle` that defines the boundaries of the form's drawing area. Rectangles are really useful—you can create a new rectangle by specifying a `Point` for its upper left-hand corner, its width and its height. Once you do that, it'll automatically calculate its `Top`, `Left`, `Right` and `Bottom` properties for you. And it's got **useful methods like `Contains()`, which will return true if a given point is inside it.**

```
g.FillRectangle(Brushes.SkyBlue, ClientRectangle);
```

This will come in really handy later on in the book! What do you think you'll be doing with `Contains()`?

3 Draw the bee and the flower

You already know how the `DrawImage()` method works.

```
g.DrawImage(Properties.Resources.Bee_animation_1, 50, 20, 75, 75);
g.DrawImage(Properties.Resources.Flower, 10, 130, 100, 150);
```

4 Add a pen that you can draw with

Every time you draw a line, you use a `Pen` object to determine its color and thickness. There's a built-in `Pens` class that gives you plenty of pens (`Pens.Red` is a thin red pen, for example). But you can create your own pen using the `Pen` class constructor, which takes a `Brush` object and a thickness (it's a float, so make sure it ends with `F`). Brushes are how you draw filled graphics (like filled rectangles and ellipses), and there's a `Brushes` class that gives you brushes in various colors.

```
using (Pen thickBlackPen = new Pen(Brushes.Black, 3.0F)) {
```

Pens are for drawing lines, and they have a width. If you want to draw a filled shape or some text, you'll need a `Brush`.

5 Add an arrow that points to the flower

There are some Graphics methods that take an array of Points, and connect them using a series of lines or curves. We'll use the `DrawLines()` method to draw the arrow head, and the `DrawCurve()` method to draw its shaft. There are other methods that take point arrays, too (like `DrawPolygon()`, which draws a closed shape, and `FillPolygon()`, which fills it in.)

```
g.DrawLines(thickBlackPen, new Point[] {
    new Point(130, 110), new Point(120, 160), new Point(155, 163)});
g.DrawCurve(thickBlackPen, new Point[] {
    new Point(120, 160), new Point(175, 120), new Point(215, 70) });
}
```

This goes inside the inner using statement that created the Pen.

Here's where the using block ends—we don't need the `thickBlackPen` any more, so it'll get disposed.

When you pass an array of points to `DrawCurve()`, it draws a smooth curve that connects them all in order.

6 Add a font to draw the text

Whenever you work with drawing text, the first thing you need to do is create a `Font` object. Again, use a using statement because `Font` implements `IDisposable`. Creating a font is straightforward. There are several overloaded constructors—the simplest one takes a font name, font size, and `FontStyle` enum.

```
using (Font font = new Font("Arial", 16, FontStyle.Italic)) {
```

7 Add some text that says "Nectar here"

Now that you've got a font, you can figure out where to put the string by measuring how big it will be when it's drawn. The `MeasureString()` method returns a `SizeF` that defines its size. (`SizeF` is just the float version of `Size`—and both of them just define a width and height.) Since we know where the arrow ends, we'll use the string measurements to position its center just above the arrow.

```
    SizeF size = g.MeasureString("Nectar here", font);
    g.DrawString("Nectar here", font, Brushes.Red, new Point(
        215 - (int)size.Width / 2, 70 - (int)size.Height));
}
```

Make sure you close out both using blocks.

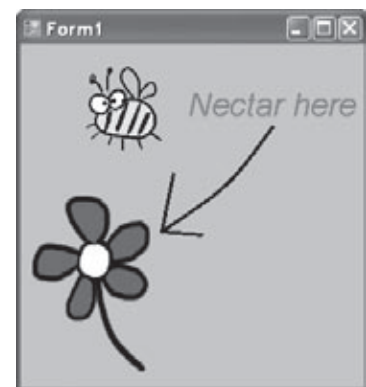

You can create a `Rectangle` by giving it a point and a `Size` (or width and height). Once you've got it, you can find its boundaries and check its `Contains()` method to see if it contains a `Point`.



1. Most of your work with Graphics will involve thinking about your forms as a grid of X,Y coordinates. Here's the code to build the grid shown below; your job is to fill in the missing parts.

```
using (Graphics g = this.CreateGraphics())
using (Font f = new Font("Arial", 6, FontStyle.Regular)) {
    for (int x = 0; x < this.Width; x += 20) {
        .....
    } .....
    for (int y = 0; y < this.Height; y += 20) {
        .....
    } .....
}
```

2. Can you figure out what happens when you run the code below? Draw the output onto the form, using the grid you just rendered for locating specific points.

```
using (Pen pen =
    new Pen(Brushes.Black, 3.0F)) {
    g.DrawCurve(pen, new Point[] {
        new Point(80, 60),
        new Point(200,40),
        new Point(180, 60),
        new Point(300,40),
    });
    g.DrawCurve(pen, new Point[] {
        new Point(300,180), new Point(180, 200),
        new Point(200,180), new Point(80, 200),
    });
    g.DrawLine(pen, 300, 40, 300, 180);
    g.DrawLine(pen, 80, 60, 80, 200);
    g.DrawEllipse(pen, 40, 40, 20, 20);
    g.DrawRectangle(pen, 40, 60, 20, 300);
    g.DrawLine(pen, 60, 60, 80, 60);
    g.DrawLine(pen, 60, 200, 80, 200);
}
```

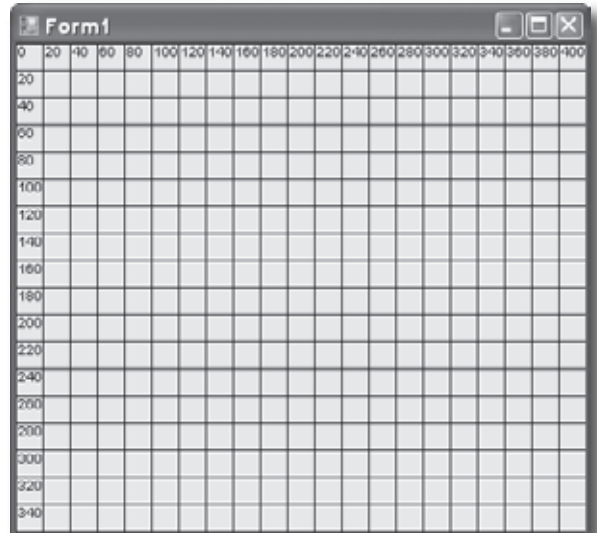

3. Here's some more graphics code, dealing with irregular shapes. Figure out what's drawn using the grid we've given you below.

```
g.FillPolygon(Brushes.Black, new Point[] {
    new Point(60,40), new Point(140,80), new Point(200,40),
    new Point(300,80), new Point(380,60), new Point(340,140),
    new Point(320,180), new Point(380,240), new Point(320,300),
    new Point(340,340), new Point(240,320), new Point(180,340),
    new Point(20,320), new Point(60, 280), new Point(100, 240),
    new Point(40, 220), new Point(80,160),
});
```

```
using (Font big = new Font("Times New Roman", 24, FontStyle.Italic)) {
    g.DrawString("Pow!", big, Brushes.White, new Point(80, 80));
    g.DrawString("Pow!", big, Brushes.White, new Point(120, 120));
    g.DrawString("Pow!", big, Brushes.White, new Point(160, 160));
    g.DrawString("Pow!", big, Brushes.White, new Point(200, 200));
    g.DrawString("Pow!", big, Brushes.White, new Point(240, 240));
}
```

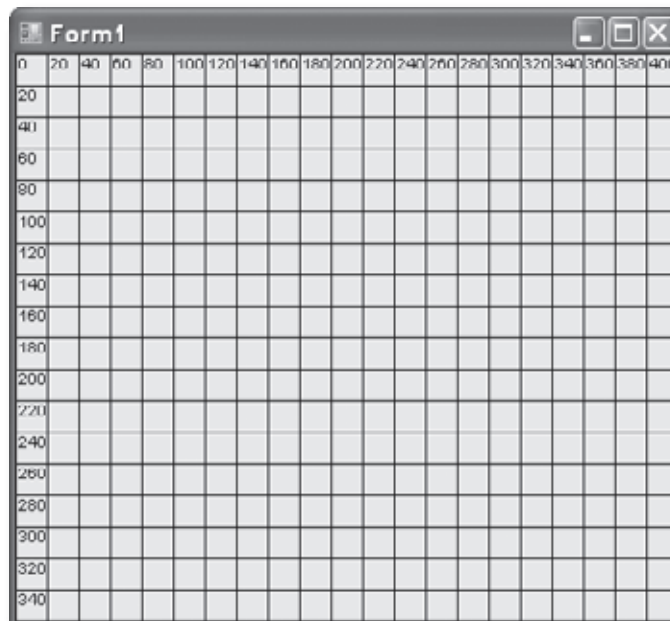

FillPolygon(), DrawLines(), and a few other graphics methods have a constructor that takes an array of Points that define the vertices of a series of connected lines.



looks good, except...

Sharpen your pencil Solution

Your job was to fill in the missing code to draw a grid, and plot two chunks of code on the grids.

```
using (Graphics g = this.CreateGraphics())
using (Font f = new Font("Arial", 6, FontStyle.Regular)) {
    for (int x = 0; x < this.Width; x += 20) {
        g.DrawLine(Pens.Black, x, 0, x, this.Height);
        g.DrawString(x.ToString(), f, Brushes.Black, x, 0);
    }
    for (int y = 0; y < this.Height; y += 20) {
        g.DrawLine(Pens.Black, 0, y, this.Width, y);
        g.DrawString(y.ToString(), f, Brushes.Black, 0, y);
    }
}
```

First we draw the vertical lines and the numbers along the y axis. There's a vertical line every 20 pixels along the X axis.

We used using statements to make sure the Graphics and Font object get disposed after the form's drawn.

Next we draw the horizontal lines and X axis numbers. To draw a horizontal line, you choose a Y value and draw a line from (0, y) on the left of the form to (0, this.Width) on the right-hand side of the form.

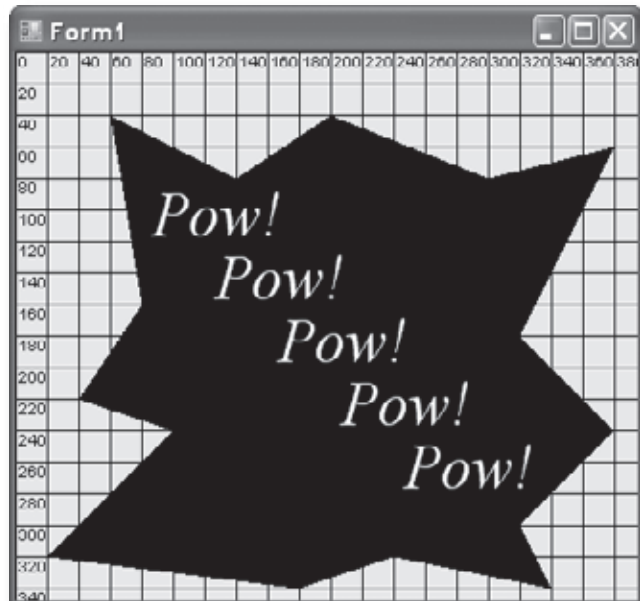
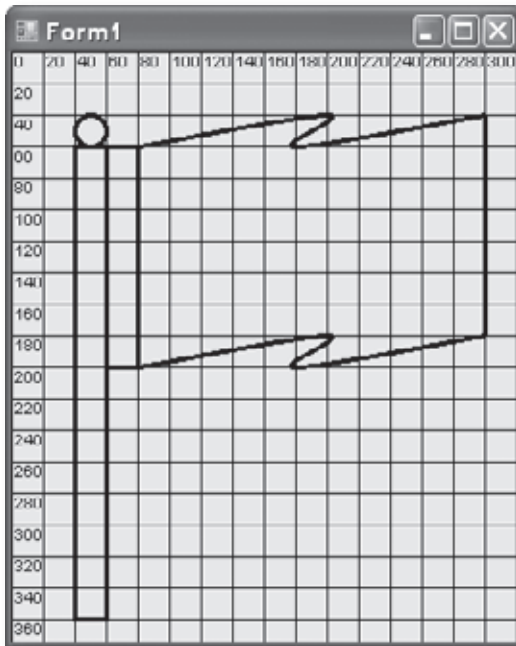

Graphics can fix our transparency problem...

Remember those pesky graphics glitches? Well, `DrawImage()` is the key to fixing the problem in the renderer where the images were drawing those boxes around the bees and flowers that caused the overlap issues. So let's tackle them! We'll start out by going back to your Windows application with the picture and changing it to draw a bunch of bees that overlap each other without any graphics glitches.

- 1 Add a `DrawBee()` method that draws a bee on any `Graphics` object. It uses the overloaded `DrawImage()` constructor that takes a `Rectangle` to determine where to draw the image, and how big to draw it.

```
public void DrawBee(Graphics g, Rectangle rect) {
    g.DrawImage(Properties.Resources.Bee_animation_1, rect);
}
```

- 2 Here's the new **Click event handler for the form**. Take a close look at how it works—it draws the hive so that its upper left-hand corner is way off the form, at location `(-Width, -Height)`, and it draws it at twice the width and height of the form—so you can resize the form and it'll still draw okay. Then it draws four bees using the `DrawBee()` method.

```
private void Form1_Click(object sender, EventArgs e) {
    using (Graphics g = CreateGraphics()) {
        g.DrawImage(Properties.Resources.Hive_inside_,
            -Width, -Height, Width * 2, Height * 2);
        Size size = new Size(Width / 5, Height / 5);
        DrawBee(g, new Rectangle(
            new Point(Width / 2 - 50, Height / 2 - 40), size));
        DrawBee(g, new Rectangle(
            new Point(Width / 2 - 20, Height / 2 - 60), size));
        DrawBee(g, new Rectangle(
            new Point(Width / 2 - 80, Height / 2 - 30), size));
        DrawBee(g, new Rectangle(
            new Point(Width / 2 - 90, Height / 2 - 80), size));
    }
}
```

First we'll draw the hive background, with its corner far off the page so we only see a small piece of it. Then we'll draw four bees so that they overlap—if they don't, make your form bigger and then click on it again so they do.

...but there's a catch

- 3 Run your program and click on the form, and watch it draw the bees! But something's wrong. When you drag the form off the side of the screen and back again, **the picture disappears!** Now go back and check the "Nectar here" program you wrote a few pages ago—it's got the same problem!

What do you think happened?

The renderer drew the bees so that they looked weird when they overlapped.

Do this



Much better—click on the form and the bees overlap just fine.



But look what happens if you drag it off the side of the screen and back! Oh no!



Use the Paint event to make your graphics stick

What good are graphics if they disappear from your form as soon as part of your form gets covered up? They're no good at all. Luckily, there's an easy way to make sure your graphics stay on your form: just **write a Paint event handler**. Your form fires a Paint event every time it needs to redraw itself—like when it's dragged off the screen. One of the properties of its `PaintEventArgs` parameter is a `Graphics` object called `Graphics`, and anything that you draw with it will “stick”.

1 Add a Paint event handler

Double-click on “Paint” in the Events page in the Properties window to add a Paint event handler. The Paint event is fired any time the image on your form gets “dirty”. So drawing your graphics inside of it will make your image will stick around.

Double-click on Paint to add a Paint event handler. Its `PaintEventArgs` has a property called `Graphics`—and anything you draw with it will stick to your form.

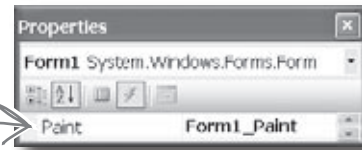

2 Use the Graphics object from the Paint event's EventArgs

Instead of starting with a using statement, make your event handler start like this:

```
private void Form1_Paint(object sender, PaintEventArgs e) {
    Graphics g = e.Graphics;
}
```

You **don't** have to use a **using** statement—since you didn't create it, **you don't have to dispose it**.

3 Copy the code that draws the overlapping bees and hive

Add the new `DrawBee()` method from the previous page into your new user control. Then copy the code from the Click event into your new Paint event—**except for the first line with the using statement**, since you already have a `Graphics` object called `g`. (Since you don't have the using statement any more, make sure you take out its closing curly bracket.) Now run your program. **The graphics stick!**

Do the same with your “Nectar here” drawing to make it stick, too.

Forms and controls redraw themselves all the time

It may not look like it, but your forms have to redraw themselves all the time. Any time you have controls on a form, they're displaying graphics—labels display text, buttons display a picture of a button, checkboxes draw a little box with an X in it. You work with them as controls that you drag around, but each control actually draws its own image. Any time you drag a form off the screen or under another form and then drag it back or uncover it, the part of the form that was covered up is now invalid, which means that it no longer shows the image that it's supposed to. That's when .NET sends a message to the form telling it to redraw itself. The form fires off a Paint event any time it's “dirty” and needs to be redrawn. If you ever want your form or user control to redraw itself, you can tell .NET to make it “dirty” by calling its `Invalidate()` method.

Forms and controls have a Paint event that gives you a Graphics object. Anything you draw on it is repainted automatically.



Exercise

See if you can combine your knowledge of forms and user controls—and get a little more practice using `Bitmap` objects and the `DrawImage()` method—by building a user control that uses `TrackBars` to zoom an image in and out.

1 Add two `TrackBar` controls to a new user control

Create a new Windows Application project. **Add a User Control**—call it `Zoomer`—and set its `Size` property to (300, 300). Drag two `TrackBar` controls out of the toolbox and onto it. Drag `trackBar1` to the bottom of the control. Then drag `trackBar2` to the right-hand side of the control and set its `Orientation` property to `Vertical`. Both should have the `Minimum` property set to 1, `Maximum` set to 175, `Value` set to 175, and `TickStyle` set to `None`. Set each `TrackBar`'s background color to white. Finally, double-click on each trackbar to add a `Scroll` event handler. Make both event handlers call the control's `Invalidate()` method.

Your user control has a `Paint` event, and it works just like the one you just used in the form. Just use its `PaintEventArgs` parameter `e`. It has a property called `Graphics`, and anything that you draw with that `Graphics` object will be painted onto any instance of the user control you drag out of the Toolbox.



Give the two trackbars white backgrounds because you'll be drawing a white rectangle behind everything, and you want them to blend in.

2 Load a picture into a `Bitmap` object and draw it on the control

Add a private `Bitmap` field called `photo` to your `Zoomer` user control. When you create the instance of `Bitmap`, use its constructor to load your favorite image file—we used a picture of a fluffy dog. Then add a `Paint` event to the control. The event handler should create a `graphics` object to draw on the control, draw a white filled rectangle over the entire control, and then use `DrawImage()` to draw the contents of your `photo` field onto your control so its upper left-hand corner is at (10, 10), its width is `trackBar1.Value`, and its height is `trackBar2.Value`. Then drag your control onto the form—make sure to resize the form so the trackbars are at the edges.

When you move the trackbars, the picture will shrink and grow!

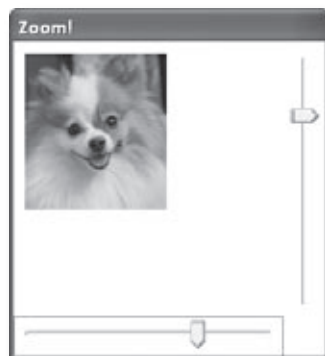

Whenever the user scrolls one of the `TrackBars`, they call the user control's `Invalidate()` method. That will cause the user control to fire its `Paint` event and resize the photo. Remember, since you didn't create the `Graphics` object—it was passed to you in `PaintEventArgs`—you don't need to dispose it. So you don't have to use a `using` statement with it. Just draw the image inside the `Paint` event handler.



Exercise Solution

Get a little more practice using Bitmap objects and the DrawImage() method by building a form that uses them to load a picture from a file and zoom it in and out.

This particular Bitmap constructor loads its picture from a file. It's got other overloaded constructors, including one that lets you specify a width and height—that one creates an empty bitmap.

```
public partial class Zoomer : UserControl {
    Bitmap photo = new Bitmap(@"c:\Graphics\fluffy_dog.jpg");

    public Zoomer() {
        InitializeComponent();
    }

    private void Zoomer_Paint(object sender, PaintEventArgs e) {
        Graphics g = e.Graphics;
        g.FillRectangle(Brushes.White, 0, 0, Width, Height);
        g.DrawImage(photo, 10, 10, trackBar1.Value, trackBar2.Value);
    }

    private void trackBar1_Scroll(object sender, EventArgs e) {
        Invalidate();
    }

    private void trackBar2_Scroll(object sender, EventArgs e) {
        Invalidate();
    }
}
```

First we draw a big white rectangle so it fills up the whole control, then we draw the photo on top of it. The last two parameters determine the size of the image being drawn—trackBar1 sets the width, trackBar2 sets the height.

Every time the user slides one of the trackbar controls, it fires off a Scroll event. By making the event handlers call the control's Invalidate() method, we cause the form to repaint itself... and when it does, it draws a new copy of the image with a different size.



Each drag here is causing another image resize from DrawImage().

```
g.DrawImage(myBitmap, 30, 30, 150, 150);
```



A closer look at how forms and controls repaint themselves



Remember earlier, we said that when you start working with Graphics objects, you're really taking control of graphics. It's like you tell .NET, "Hey, I know what I'm doing, I can handle the extra responsibility." In the case of drawing and redrawing, you may not want to redraw when a form is minimized and maximized... or you may want to redraw **more often**. Once you know what's going on behind the scenes with your form or control, you can take control of redrawing yourself:

1 Every form has a Paint event that draws the graphics on the form

Go to the event list for any form and find the event called **Paint**. Whenever the form has to repaint itself, this event is fired. Every form and control uses a **Paint** event internally to decide when to redraw itself. But what fires that event? It's called by a method called **OnPaint** that the form or user control inherits from the Control class. (That method follows the pattern you saw in Chapter 11, where methods that fire an event are named "On" followed by the event name.) Go to any form and override OnPaint:

Override OnPaint on any form and add this line. →

```
protected override void OnPaint(PaintEventArgs e) {
    Console.WriteLine("OnPaint {0} {1}", DateTime.Now, e.ClipRectangle);
    base.OnPaint(e);
}
```

Do this just like you did earlier with Dispose()

Drag your form around—drag it halfway off the screen, minimize it, hide it behind other windows. Watch closely at the output that it writes. You'll see that your **OnPaint** method fires off a **Paint** event any time part of it is "dirty"—or **invalid**—and needs to be redrawn. And if you look closely at the **ClipRectangle**, you'll see that it's a rectangle that describes the part of the form that needs to be repainted. That gets passed to the **Paint** event's **PaintEventArgs** so it can improve performance by only redrawing the portion that's invalid.

2 Invalidate() controls when to redraw, and WHAT to redraw

.NET fires the **Paint** event when something on a form is interfered with, covered up, or moved offscreen, and then shown again. It calls **Invalidate()**, and passes the method a **Rectangle**. The **Rectangle** tells the **Invalidate()** method what part of the form needs to be redrawn... what part of the form is "dirty." Then .NET calls **OnPaint** to tell your form to fire a **Paint** event and repaint the dirty area.

Invalidate() essentially says, some part of the form might be "invalid," so redraw that part to make sure it's got the right things showing.

3 The Update() method gives your Invalidate request top priority

You may not realize it, but your form is getting messages all the time. The same system that tells it that it's been covered up and calls **OnPaint** has all sorts of other messages it needs to send. See for yourself: type **override** and scroll through all the methods that start with "On"—every one of them is a message your form responds to. The **Update()** method moves the **Invalidate** message to the top of the message list.

So when you call it yourself, you're telling .NET that your whole form or control is invalid, and the whole thing needs to be redrawn. You can pass it your own clip rectangle if you want—that'll get passed along to the **Paint** event's **PaintEventArgs**.

4 The form's Refresh() method is Invalidate() plus Update()

Forms and controls give you a shortcut. They have a **Refresh()** method that first calls **Invalidate()** to invalidate the whole client area, and then calls **Update()** to make sure that message moves to the top of the list.

there are no Dumb Questions

Q: It still seems like just resizing the graphics in a program like Paint or PhotoShop would be better. Why can't I do that?

A: You can, if you're in control of the images you work with in your applications, and if they'll always stay the same size. But that's not often the case. Lots of times, you'll get images from another source, whether it's online or a co-worker in the design group. Or, you may be pulling an image from a read-only source, and you have to size it in code.

Q: But if I can resize it outside of .NET, that's better, right?

A: If you're sure you'll never need a larger size, it could be. But if your program might need to display the image in multiple sizes during the program, you'll have to resize at some point anyway. Plus, if your image ever needs to be displayed larger than the resize, you'll end up in real trouble. It's much easier to size down than it is to size up.

More often than not, it's better to be able to resize an image programmatically, than to be limited by an external program or constraints like read-only files.

Q: I get that `CreateGraphics()` gets the Graphics object for drawing on a form, but what was that `FromImage()` call in the `ResizeImage()` method about?

A: `FromImage()` retrieves the Graphics object for a Bitmap object. And just as `CreateGraphics()` called on a form returns the Graphics object for drawing on that form, `FromImage()` retrieves a Graphics object for drawing on the Bitmap the method was called on.

Q: So a Graphics object isn't just for drawing on a form?

A: Actually, a Graphics object is for drawing on, well, anything that gives you a Graphics object. The Bitmap gives you a Graphics object that you can use to draw onto an invisible image that you can use later. And you'll find Graphics objects on a lot more than forms. Drag a button onto a form, then go into your code and type its name followed by a period. Check out the IntelliSense window that popped up—it's got a `CreateGraphics()` method that returns a Graphics object. Anything you draw on it will show up on the button! Same goes for Label, PictureBox, StatusStrip... almost every toolbox control has a Graphics object.

Q: Wait, I thought `using` was just something I used with streams. Why am I using `using` with graphics?

A: The `using` keyword comes in handy with streams, but it's something that you use with *any* class that implements the `IDisposable` interface. When you instantiate a class that implements `IDisposable`, you should always call its `Dispose()` method when you're done with the object. That way it knows to clean up after itself. With streams, the `Dispose()` method makes sure that any file that was opened gets closed.

Graphics, Pen, and Brush objects are also disposable. When you create any of them, they take up some small amount of memory and other resources, and they don't always give them back immediately. If you're just drawing something once, you won't notice a difference. But most of the time, your graphics code will be called over and over and over again—like in a Paint event handler, which could get

called many times a second for a particularly busy form. That's why you should always `Dispose()` of your graphics-related objects. And the easiest way to make sure that you do is to use a `using` line, and let .NET worry about disposal. Any object you create with `using` will automatically have its `Dispose()` method called at the end of the block following the `using` statement. That will guarantee that your program won't slowly take up more and more memory if it runs for a long time.

Q: If I'm creating a new control, should I use a UserControl or should I create a class that inherits from one of the toolbox controls?

A: That depends on what you want your new control to do. If you're building a control that's really similar to one that's already in the toolbox, then you'll probably find it easiest to inherit from that control. But most of the time, when programmers create new controls in C#, they use user controls. One useful advantage of a user control is that you can **drag toolbox controls onto it**. It works a lot like a `GroupBox` or other container control—you can drag a button or checkbox onto your user control, and work with them just like you'd work with controls on a form. The IDE's form designer becomes a powerful tool to help you design user controls.

A user control can host other controls. The IDE's form designer lets you drag controls out of the toolbox and onto your new user control.

I noticed a whole lot of flickering in my Zoomer control. With all this talk of taking control of graphics, I'll bet there's something we can do about that! But why does it happen?

Even without resizing, it takes time to draw an image to a form.

Suppose you've got every image in the simulator resized. It still takes time to draw all those bees and flowers and the hive. And right now, we're drawing right to the Graphics object on the form. So if your eye catches the tail end of a render, you're going to perceive it as a little flicker.

The problem is that a lot of drawing is happening, so there's a good chance that some flickering will occur, even with our resizing. And that's why you run into problems with some amateur computer games, for example: the human eye catches the end of a rendering cycle, and perceives it as a little bit of flickering on the screen.



BRAIN POWER

How could you get rid of this flicker? If drawing lots of images to the form causes flickering, and you have to draw lots of images, how do you think you might be able to avoid all the flickering?

Double buffering makes animation look a lot smoother

Go back to your image zoomer and fiddle with the trackbars. Notice how there's a whole lot of flickering when you move the bars? That's because the `Paint` event handler first has to draw the white rectangle and then draw the image every time the trackbar moves a tiny little bit. When your eyes see alternating white rectangles and images many times a second, they interpret that as flicker. It's irritating.. and it's avoidable using a technique called **double buffering**. That means drawing each frame or cell of animation to an invisible bitmap (a "buffer"), and only displaying the new frame once it's been drawn entirely. Here's how it would work with a `Bitmap`:

- 1 Here's a typical program that draws some graphics on a form using its `Graphics` object.

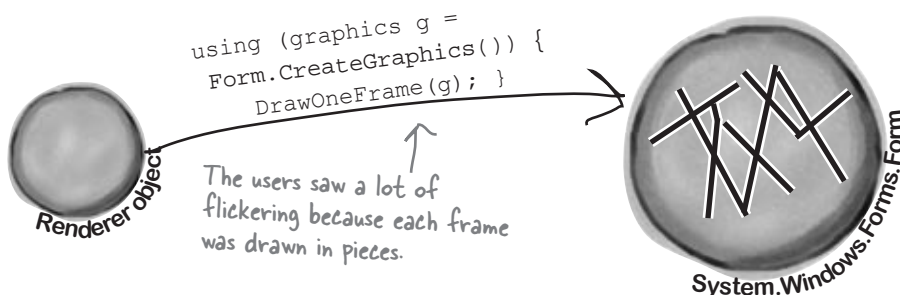

- 2 To do double buffering, we can add a `Bitmap` object to the program to act as a buffer. Every time our form or control needs to be repainted, instead of drawing the graphics directly on the form, we draw on the buffer instead.

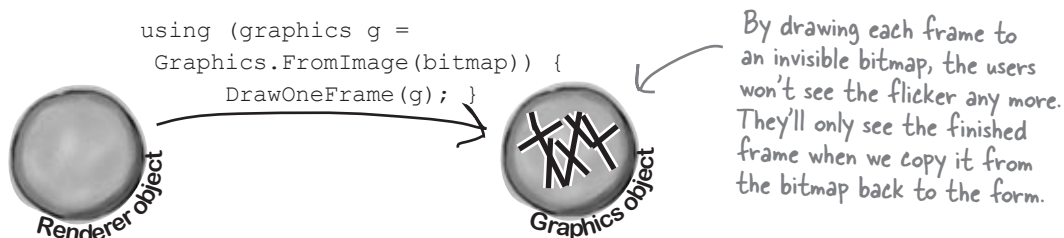

- 3 Now that the frame is completely drawn out to the invisible `Bitmap` object, we can use `DrawImageUnscaled()` to copy the object back to the form's `Graphics`. It all gets copied at once, and that eliminates the flicker.

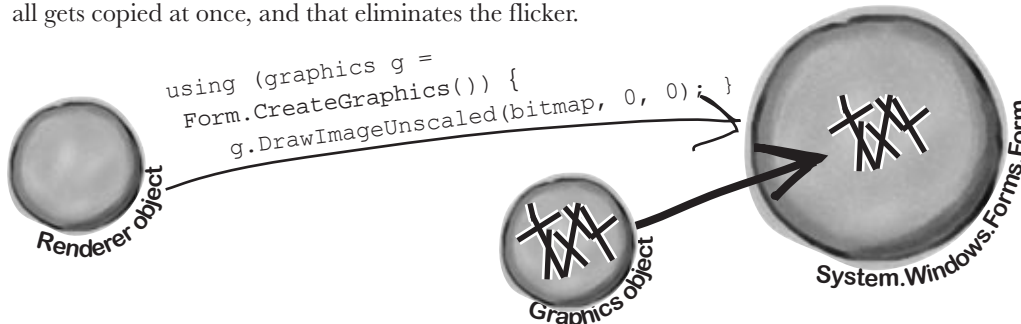

Double buffering is built into forms and controls

You can do double buffering yourself using a `Bitmap`, but C# and .NET make it even easier with built-in support for double buffering. **All you need to do is set its `DoubleBuffered` property to true.** Try it out on your `Zoomer` user control—go to its Properties window, set `DoubleBuffered` to true, and your control will stop flickering! Now **go back to your `BeeControl`** and do the same. That won't fix all of the graphics problems—we'll do that in a minute—but it *will* make a difference.

Now you're ready to fix the graphics problems in the simulator!

Overhaul the Beehive Simulator

In the next exercise, you'll take your `Beehive Simulator` and completely overhaul it. You'll probably want to create a whole new project and use “Add >> Existing Item...” to add the current files to it so you have a backup of your current simulator. (Don't forget to change their namespace to match your new project.)

Here's what you're going to do:

- 1 You'll start by removing the `BeeControl` user control**

There won't be any controls on the hive and field at all. No `BeeControls`, no `PictureBoxes`, nothing. The bees, flowers, and hive pictures will all be drawn using GDI+ graphics. So right-click on `BeeControl.cs` (and `OldBeeControl.cs`) in the Solution Explorer and click Delete—they'll be removed from the project and permanently deleted.
- 2 You'll need a timer to handle the bee wing flapping**

The bees flap their wings much more slowly than the simulator's frame rate, so you'll need a second, slower timer. This shouldn't be too surprising, since the `BeeControl` had its own timer to do the same thing.
- 3 The big step: overhaul the renderer**

You'll need to throw out the current renderer entirely, because it does everything with controls. You won't need those lookup dictionaries, because there won't be any `PictureBoxes` or `BeeControls` to look up. Instead, it'll have two important methods: `DrawHive(g)` will draw a `Hive` form on a graphics object, and `DrawField(g)` will draw a `Field` form.
- 4 Last of all, you'll hook up the new renderer**

The `Hive` and `Field` forms will need `Paint` event handlers. Each of them will call the `Renderer` object's `DrawField(g)` or `DrawHive(g)` methods. The two timers—one for telling the simulator to draw the next frame, and the other to flap the bees' wings—will call the two forms' `Invalidate()` methods to repaint themselves. When they do, their `Paint` event handlers will render the frame.

Let's get started!



When you use the `Paint` event for all your graphics, you can turn on double buffered painting simply by changing one property.



Exercise

It's time to get rid of the graphics glitches in the beehive simulator. Use graphics and double buffering to make the simulator look polished.

1 Change the main form's RunFrame() method

You'll need to remove the call to `Renderer.Render()` and add two `Invalidate()` statements.

```
public void RunFrame(object sender, EventArgs e) {
    framesRun++;
    world.Go(random);
    end = DateTime.Now;
    TimeSpan frameDuration = end - start;
    start = end;
    UpdateStats(frameDuration);
    hiveForm.Invalidate();
    fieldForm.Invalidate();
}
```

You'll need to remove the call to `renderer.Render()`, since that method will go away.

As long as you keep the world up to date and both forms have a reference to the renderer object, all you need to do to animate them is call their `Invalidate()` methods. Their `Paint` event handlers will take care of the rest.

2 Add a second timer to the main form to make the bees' wings flap

Drag a new timer onto the main form, set its `Interval` to 150ms and `Enabled` to true. Then double-click on it and add this event handler:

```
private void timer2_Tick(object sender, EventArgs e) {
    renderer.AnimateBees();
}
```

Then add this `AnimateBees()` method to the renderer to make the bees' wings flap:

```
private int Cell = 0;
private int Frame = 0;
private void AnimateBees() {
    Frame++;
    if (Frame >= 6)
        Frame = 0;
    switch (Frame) {
        case 0: Cell = 0; break;
        case 1: Cell = 1; break;
        case 2: Cell = 2; break;
        case 3: Cell = 3; break;
        case 4: Cell = 2; break;
        case 5: Cell = 1; break;
        default: Cell = 0; break;
    }
    hiveForm.Invalidate();
    fieldForm.Invalidate();
}
```

The whole idea here is to set a field called `Cell` that you can use when you're drawing the bees in the renderer. Make sure you're always drawing `BeeAnimationLarge[Cell]` in the hive form and `BeeAnimationSmall[Cell]` in the field form. The timer will constantly call the `AnimateBees()` method, which will cause the `Cell` field to keep changing, which will cause your bees to flap their wings.

3 Set up the hive and field forms for double-buffered animation

Remove the code from the hive form's constructor that sets the background image. Then remove all controls from both forms and **set their DoubleBuffered properties to true**. Finally, add a Paint event handler to each of them. Here's the handler for the hive form—the field form's Paint event handler is identical, except that it calls `renderer.PaintField()` instead of `renderer.PaintHive()`:

```
private void HiveForm_Paint(object sender, PaintEventArgs e) {
    renderer.PaintHive(e.Graphics);
}
```

Make sure you turn on double buffering, or your forms will flicker!

4 The hive form and field form both need a public renderer property

Add a public field to the hive form and the field form:

```
public Renderer renderer;
```

There are two places where you create a new `Renderer()`: in the open button (underneath a call to `renderer.Reset()`) and in the `ResetSimulator()` method. Remove all calls to `renderer.Reset()`, and replace each of the new `renderer` statements with a call to this new `CreateRenderer()` method that you'll add:

```
private void CreateRenderer() {
    renderer = new Renderer(world, hiveForm, fieldForm);
    hiveForm.renderer = renderer;
    fieldForm.renderer = renderer;
}
```

You won't need a `Reset()` method in the `renderer` any more. All it did was remove the controls from the forms, and there won't be any controls to remove.

5 Overhaul the renderer by removing control-based code and adding graphics

Here's what you need to do to fix the renderer:

- ★ Remove the two dictionaries, since there aren't any more controls. And while you're at it, you don't need the `BeeControl` any more, or the `Render()`, `DrawBees()`, or `DrawFlowers()` methods..
- ★ Add some `Bitmap` fields called `HiveInside`, `HiveOutside`, and `Flower` to store the images. Then create two `Bitmap[]` arrays called `BeeAnimationLarge` and `BeeAnimationSmall`. Each of them will hold four bee pictures—the large ones are 40x40 and the small are 20x20. Create a method called `InitializeImages()` to resize the resources and store them in these fields, and call it from the `Renderer` class constructor.
- ★ Add the `PaintHive()` method that takes a `Graphics` object as a parameter and paints the hive form onto it. First draw a sky blue rectangle, then use `DrawImageUnscaled()` to draw the inside hive picture, then use `DrawImageUnscaled()` to draw each of the bees that are inside the hive.
- ★ Finally, add the `PaintField()` method. It should draw a sky blue rectangle on the top half of the form, and a green rectangle on the bottom half. You'll find two form properties helpful for this: `ClientSize` and `ClientRectangle` tell you how big the drawing area is, so you can find half of its height using `ClientSize.Height / 2`. Then use `FillEllipse()` to draw a yellow sun in the sky, `DrawLine()` to draw a thick line for a branch the hive can hang from, and `DrawImageUnscaled()` to draw the outside hive picture. Then draw each flower onto the form. Finally, draw each bee (using the small bee pictures)—draw them last so they're in front of the flowers.
- ★ When you're drawing the bees, remember that `AnimateBees()` sets the `Cell` field.



Exercise Solution

It's time to get rid of the graphics glitches in the beehive simulator. Use graphics and double buffering to make the simulator look polished.

```
using System.Drawing;
```

```
public class Renderer {
    private World world;
    private HiveForm hiveForm;
    private FieldForm fieldForm;
```

```
    public Renderer(World TheWorld, HiveForm hiveForm, FieldForm fieldForm) {
        this.world = TheWorld;
        this.hiveForm = hiveForm;
        this.fieldForm = fieldForm;
        InitializeImages();
    }
```

```
    public static Bitmap ResizeImage(Image ImageToResize, int Width, int Height) {
        Bitmap bitmap = new Bitmap(Width, Height);
        using (Graphics graphics = Graphics.FromImage(bitmap)) {
            graphics.DrawImage(ImageToResize, 0, 0, Width, Height);
        }
        return bitmap;
    }
```

```
    Bitmap HiveInside;
    Bitmap HiveOutside;
    Bitmap Flower;
    Bitmap[] BeeAnimationSmall;
    Bitmap[] BeeAnimationLarge;
```

```
    private void InitializeImages() {
        HiveOutside = ResizeImage(Properties.Resources.Hive_outside_, 85, 100);
        Flower = ResizeImage(Properties.Resources.Flower, 75, 75);
        HiveInside = ResizeImage(Properties.Resources.Hive_inside_,
            hiveForm.ClientRectangle.Width, hiveForm.ClientRectangle.Height);
        BeeAnimationLarge = new Bitmap[4];
        BeeAnimationLarge[0] = ResizeImage(Properties.Resources.Bee_animation_1, 40, 40);
        BeeAnimationLarge[1] = ResizeImage(Properties.Resources.Bee_animation_2, 40, 40);
        BeeAnimationLarge[2] = ResizeImage(Properties.Resources.Bee_animation_3, 40, 40);
        BeeAnimationLarge[3] = ResizeImage(Properties.Resources.Bee_animation_4, 40, 40);
        BeeAnimationSmall = new Bitmap[4];
        BeeAnimationSmall[0] = ResizeImage(Properties.Resources.Bee_animation_1, 20, 20);
        BeeAnimationSmall[1] = ResizeImage(Properties.Resources.Bee_animation_2, 20, 20);
        BeeAnimationSmall[2] = ResizeImage(Properties.Resources.Bee_animation_3, 20, 20);
        BeeAnimationSmall[3] = ResizeImage(Properties.Resources.Bee_animation_4, 20, 20);
    }
```

Here's the complete `Renderer` class, including the `AnimateBees()` method that we gave you. Make sure you make all the modifications to the three forms—especially the `Paint` event handlers in the hive and field forms. Those event handlers call the renderer's `PaintHive()` and `PaintField()` methods, which do all of the animation.

The `InitializeImages()` method resizes all of the image resources and stores them in `Bitmap` fields inside the `Renderer` object. That way the `PaintHive()` and `PaintForm()` methods can draw the images unscaled using the forms' `Graphics` objects' `DrawImageUnscaled()` methods.

```

public void PaintHive(Graphics g) {
    g.FillRectangle(Brushes.SkyBlue, hiveForm.ClientRectangle);
    g.DrawImageUnscaled(HiveInside, 0, 0);
    foreach (Bee bee in world.Bees) {
        if (bee.InsideHive)
            g.DrawImageUnscaled(BeeAnimationLarge[Cell],
                bee.Location.X, bee.Location.Y);
    }
}

```

A form's `ClientSize` property is a `Rectangle` that tells you how big its drawing area is.

```

public void PaintField(Graphics g) {
    using (Pen brownPen = new Pen(Color.Brown, 6.0F)) {
        g.FillRectangle(Brushes.SkyBlue, 0, 0,
            fieldForm.ClientSize.Width, fieldForm.ClientSize.Height / 2);
        g.FillEllipse(Brushes.Yellow, new RectangleF(50, 15, 70, 70));
        g.FillRectangle(Brushes.Green, 0, fieldForm.ClientSize.Height / 2,
            fieldForm.ClientSize.Width, fieldForm.ClientSize.Height / 2);
        g.DrawLine(brownPen, new Point(643, 0), new Point(643, 30));
        g.DrawImageUnscaled(HiveOutside, 600, 20);
        foreach (Flower flower in world.Flowers) {
            g.DrawImageUnscaled(Flower, flower.Location.X, flower.Location.Y);
        }
        foreach (Bee bee in world.Bees) {
            if (!bee.InsideHive)
                g.DrawImageUnscaled(BeeAnimationSmall[Cell],
                    bee.Location.X, bee.Location.Y);
        }
    }
}

```

```

private int Cell = 0;
private int Frame = 0;
public void AnimateBees()
{
    Frame++;
    if (Frame >= 6)
        Frame = 0;
    switch (Frame) {
        case 0: Cell = 0; break;
        case 1: Cell = 1; break;
        case 2: Cell = 2; break;
        case 3: Cell = 3; break;
        case 4: Cell = 2; break;
        case 5: Cell = 1; break;
        default: Cell = 0; break;
    }
    hiveForm.Invalidate();
    fieldForm.Invalidate();
}
}

```

The `PaintField()` method looks at the bees and flowers in the world and draws a field using their locations. First it draws the sky and the ground, then it draws the sun, and then the beehive. After that, it draws the flowers and the bees. It's important that everything is drawn in the right order—if it were to draw the flowers before the bees, then the bees would look like they were flying behind the flowers.

Here's the same `AnimateBees()` method from the exercise. It cycles through the animations using the `Frame` field—first it shows cell 0, then cell 1, then 2, then 3, and then back to 2, then 1 again. That way the bee flapping animation is smooth.

Use a Graphics object and an event handler for printing

The `Graphics` methods you've been using to draw on your forms are **the same ones you use to print**. .NET's printing objects in `System.Drawing.Printing` make it really easy to add printing and print preview to your applications. All you need to do is **create a `PrintDocument` object**. It's got an event called `PrintPage`, which you can use exactly like you use a timer's `Tick` event. Then call the `PrintDocument` object's `Print()` method and it prints the document. And remember, the IDE makes it especially easy to add the event handler. Here's how:



- 1 **Start a new Windows application** and add a button to the form. Go to the form code and add a **using `System.Drawing.Printing`**; line to the top. Double-click on the button and add the event handler. Watch what happens as soon as you type `+=`:

```
private void button1_Click(object sender, EventArgs e) {
    PrintDocument document = new PrintDocument();
    document.PrintPage +=
```

```
new PrintPageEventHandler(document_PrintPage); (Press TAB to insert)
```

- 2 Press Tab and the IDE automatically fills in the rest of the line. This is just like how you added event handlers in Chapter 11:

```
private void button1_Click(object sender, EventArgs e) {
    PrintDocument document = new PrintDocument();
    document.PrintPage += new PrintPageEventHandler(document_PrintPage);
```

```
Press TAB to generate handler 'document_PrintPage' in this class
```

- 3 As soon as you press Tab, the IDE generates an event handler method and adds it to the form.

```
void document_PrintPage(object sender, PrintPageEventArgs e) {
    throw new NotImplementedException();
}
```

Now you can put ANY graphics code here—just replace the throw line and use `e.Graphics` for all of the drawing. We'll show you how in a minute...

The `PrintPageEventArgs` parameter `e` has a `Graphics` property. Just replace the throw statement with code that calls the `e.Graphics` object's drawing methods.

- 4 Now finish off the `button1_Click` event handler by calling **`document.Print()`**. When that method is called, the `PrintDocument` object creates a `Graphics` object and then fires off a `PrintPage` event with the `Graphics` object as a parameter. Anything that the event handler draws onto the `Graphics` object will get sent to the printer.

```
private void button1_Click(object sender, EventArgs e) {
    PrintDocument document = new PrintDocument();
    document.PrintPage += new PrintPageEventHandler(document_PrintPage);
    document.Print();
}
```

PrintDocument works with the print dialog and print preview window objects

Adding a print preview window or a print dialog box is a lot like adding an open or save dialog box. All you need to do is create a `PrintDialog` or `PrintPreviewDialog` object, set its `Document` property to your `Document` object, and then call the dialog's `Show()` method. The dialog will take care of sending the document to the printer—no need to call its `Print()` method. So let's add this to the button you created in step 1:

Once you've got a `PrintDocument` and an event handler to print the page, you can pop up a print preview window just by creating a new `PrintPreviewDialog` object.

```
private void button1_Click(object sender, EventArgs e) {
    PrintDocument document = new PrintDocument();
    document.PrintPage += new PrintPageEventHandler(document_PrintPage);
    PrintPreviewDialog preview = new PrintPreviewDialog();
    preview.Document = document;
    preview.ShowDialog(this);
}
```

```
void document_PrintPage(object sender,
    PrintPageEventArgs e) {
    DrawBee(e.Graphics, new Rectangle(0, 0, 300, 300));
}
```

We'll reuse our `DrawBee()` method from a few pages ago.

Use `e.HasMorePages` to print multi-page documents

If you need to print more than one page, all you need to do is have your `PrintPage` event handler set `e.HasMorePages` to true. That tells the `Document` that you've got another page to print. It'll call the event handler over and over again, once per page, as long as the event handler keeps setting `e.HasMorePages` to true. So modify your `Document`'s event handler to print two pages:

```
bool firstPage = true;
void document_PrintPage(object sender, PrintPageEventArgs e) {
    DrawBee(e.Graphics, new Rectangle(0, 0, 300, 300));
    using (Font font = new Font("Arial", 36, FontStyle.Bold)) {
        if (firstPage) {
            e.Graphics.DrawString("First page", Font, Brushes.Black, 0, 0);
            e.HasMorePages = true;
            firstPage = false;
        } else {
            e.Graphics.DrawString("Second page", Font, Brushes.Black, 0, 0);
            firstPage = true;
        }
    }
}
```

If you set `e.HasMorePages` to true, the `Document` object will call the event handler again to print the next page.

Now run your program again, and make sure it's displaying two pages in the print preview.





Exercise

Write the code for the Print button in the simulator so that it pops up a print preview window showing the bee stats and pictures of the hive and the field.

1

Make the button pop up a print preview window

Add an event handler for the button's click event that pauses the simulator, pops up the print preview dialog, and then resumes the simulator when it's done. (If the simulator is paused when the button is clicked, make sure it stays paused after the preview is shown.)

2

Create the document's PrintPage event handler

It should create a page that looks exactly like the one on the facing page. We'll start you off:

```
private void document_PrintPage(object sender, PrintPageEventArgs e) {
    Graphics g = e.Graphics;
    Size stringSize;
    using (Font arial24bold = new Font("Arial", 24, FontStyle.Bold)) {
        stringSize = Size.Ceiling(
            g.MeasureString("Bee Simulator", arial24bold));
        g.FillEllipse(Brushes.Gray,
            new Rectangle(e.MarginBounds.X + 2, e.MarginBounds.Y + 2,
                stringSize.Width + 30, stringSize.Height + 30));
        g.FillEllipse(Brushes.Black,
            new Rectangle(e.MarginBounds.X, e.MarginBounds.Y,
                stringSize.Width + 30, stringSize.Height + 30));
        g.DrawString("Bee Simulator", arial24bold,
            Brushes.Gray, e.MarginBounds.X + 17, e.MarginBounds.Y + 17);
        g.DrawString("Bee Simulator", arial24bold,
            Brushes.White, e.MarginBounds.X + 15, e.MarginBounds.Y + 15);
    }
    int tableX = e.MarginBounds.X + (int)stringSize.Width + 50;
    int tableWidth = e.MarginBounds.X + e.MarginBounds.Width - tableX - 20;
    int firstColumnX = tableX + 2;
    int secondColumnX = tableX + (tableWidth / 2) + 5;
    int tableY = e.MarginBounds.Y;
    // Your job: fill in the rest of the method to make it print this
```

We created the oval with text in it using the `MeasureString()` method, which returns a `Size` that contains the size of a string. We drew the oval and text twice to give it a shadow effect.

You'll need these to build the table.

3

This `PrintTableRow()` method will come in handy

You'll find this method useful when you create the table of bee stats at the top of the page.

```
private int PrintTableRow(Graphics printGraphics, int tableX,
    int tableWidth, int firstColumnX, int secondColumnX,
    int tableY, string firstColumn, string secondColumn) {
    Font arial12 = new Font("Arial", 12);
    Size stringSize = Size.Ceiling(printGraphics.MeasureString(firstColumn, arial12));
    tableY += 2;
    printGraphics.DrawString(firstColumn, arial12, Brushes.Black,
        firstColumnX, tableY);
    printGraphics.DrawString(secondColumn, arial12, Brushes.Black,
        secondColumnX, tableY);
    tableY += (int)stringSize.Height + 2;
    printGraphics.DrawLine(Pens.Black, tableX, tableY, tableX + tableWidth, tableY);
    arial12.Dispose();
    return tableY;
}
```

Each time you call `PrintTableRow()`, it adds the height of the row it printed to `tableY` and returns the new value.

Take a close look at the notes we wrote on the printout. This is a little complex—take your time!

Print preview Page 1

Use the `PrintTableRow()` method to print the rows of the table.

Bee Simulator

We used `e.MarginBounds` to keep a left margin. This ellipse starts at `e.MarginBounds.X + 2`.

Use the renderer to draw the hive form. Draw a black rectangle around it with a width of 2. Use the `Width` property in `e.MarginBounds` to make it half the width of the page.

Bees	8
Flowers	14
Honey In Hive	6.075
Nectar In Flowers	48.400
Frames Full	2978
Frame Rate	20 (50.1ms)

Then use the renderer to do the same for the field form—make it the full page width using the `X` and `Y` fields in `e.MarginBounds`. See if you can give them the same proportions as the two forms.

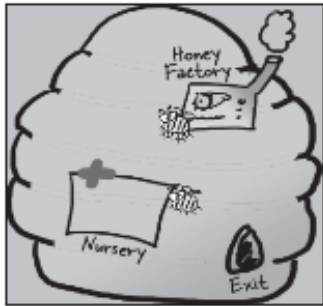
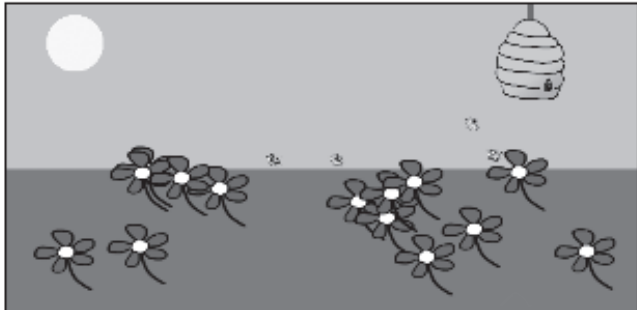
Once you figure out how tall to make the hive picture, align it to the bottom of the page.

Here's a hint: To find the height of each form, find the ratio of its height divided by its width and multiply that by the final width. You can locate the top of the field form by subtracting its height from the bottom margin of the page: $(e.MarginBounds.Y + e.MarginBounds.Height - \text{fieldHeight})$.



Exercise Solution

Write the code for the Print button in the simulator so that it pops up a print preview window showing the bee stats and pictures of the hive and the field.

Here's the event handler for the Document's PrintPage event. It goes in the form.

```
using System.Drawing.Printing;

private void document_PrintPage(object sender, PrintPageEventArgs e) {
    Graphics g = e.Graphics;

    Size stringSize;
    using (Font arial24bold = new Font("Arial", 24, FontStyle.Bold)) {
        stringSize = Size.Ceiling(
            g.MeasureString("Bee Simulator", arial24bold));
        g.FillEllipse(Brushes.Gray,
            new Rectangle(e.MarginBounds.X + 2, e.MarginBounds.Y + 2,
                stringSize.Width + 30, stringSize.Height + 30));
        g.FillEllipse(Brushes.Black,
            new Rectangle(e.MarginBounds.X, e.MarginBounds.Y,
                stringSize.Width + 30, stringSize.Height + 30));
        g.DrawString("Bee Simulator", arial24bold,
            Brushes.Gray, e.MarginBounds.X + 17, e.MarginBounds.Y + 17);
        g.DrawString("Bee Simulator", arial24bold,
            Brushes.White, e.MarginBounds.X + 15, e.MarginBounds.Y + 15);
    }

    int tableX = e.MarginBounds.X + (int)stringSize.Width + 50;
    int tableWidth = e.MarginBounds.X + e.MarginBounds.Width - tableX - 20;
    int firstColumnX = tableX + 2;
    int secondColumnX = tableX + (tableWidth / 2) + 5;
    int tableY = e.MarginBounds.Y;

    tableY = PrintTableRow(g, tableX, tableWidth, firstColumnX,
        secondColumnX, tableY, "Bees", Bees.Text);
    tableY = PrintTableRow(g, tableX, tableWidth, firstColumnX,
        secondColumnX, tableY, "Flowers", Flowers.Text);
    tableY = PrintTableRow(g, tableX, tableWidth, firstColumnX,
        secondColumnX, tableY, "Honey in Hive", HoneyInHive.Text);
    tableY = PrintTableRow(g, tableX, tableWidth, firstColumnX,
        secondColumnX, tableY, "Nectar in Flowers", NectarInFlowers.Text);
    tableY = PrintTableRow(g, tableX, tableWidth, firstColumnX,
        secondColumnX, tableY, "Frames Run", FramesRun.Text);
    tableY = PrintTableRow(g, tableX, tableWidth, firstColumnX,
        secondColumnX, tableY, "Frame Rate", FrameRate.Text);

    g.DrawRectangle(Pens.Black, tableX, e.MarginBounds.Y,
        tableWidth, tableY - e.MarginBounds.Y);
    g.DrawLine(Pens.Black, secondColumnX, e.MarginBounds.Y,
        secondColumnX, tableY);
}
```

We gave you this part already. It draws the oval header, and sets up variables that you'll use to draw the table of bee stats.

Did you figure out how the PrintTableRow() method works? All you need to do is call it once per row, and it prints whatever text you want in the two columns. The trick is that it returns the new tableY value for the next row.

Don't forget to draw the rectangle around the table and the line between the columns.

```

using (Pen blackPen = new Pen(Brushes.Black, 2))
using (Bitmap hiveBitmap = new Bitmap(hiveForm.ClientSize.Width,
                                     hiveForm.ClientSize.Height))
using (Bitmap fieldBitmap = new Bitmap(fieldForm.ClientSize.Width,
                                       fieldForm.ClientSize.Height))

using (Graphics hiveGraphics = Graphics.FromImage(hiveBitmap))
{
    renderer.PaintHive(hiveGraphics);
}

int hiveWidth = e.MarginBounds.Width / 2;
float ratio = (float)hiveBitmap.Height / (float)hiveBitmap.Width;
int hiveHeight = (int)(hiveWidth * ratio);
int hiveX = e.MarginBounds.X + (e.MarginBounds.Width - hiveWidth) / 2;
int hiveY = e.MarginBounds.Height / 3;
g.DrawImage(hiveBitmap, hiveX, hiveY, hiveWidth, hiveHeight);
g.DrawRectangle(blackPen, hiveX, hiveY, hiveWidth, hiveHeight);

using (Graphics fieldGraphics = Graphics.FromImage(fieldBitmap))
{
    renderer.PaintField(fieldGraphics);
}
int fieldWidth = e.MarginBounds.Width;
ratio = (float)fieldBitmap.Height / (float)fieldBitmap.Width;
int fieldHeight = (int)(fieldWidth * ratio);
int fieldX = e.MarginBounds.X;
int fieldY = e.MarginBounds.Y + e.MarginBounds.Height - fieldHeight;
g.DrawImage(fieldBitmap, fieldX, fieldY, fieldWidth, fieldHeight);
g.DrawRectangle(blackPen, fieldX, fieldY, fieldWidth, fieldHeight);
}
}

private void printToolStripButton_Click(object sender, EventArgs e) {
    bool stoppedTimer = false;
    if (timer1.Enabled) {
        timer1.Stop();
        stoppedTimer = true;
    }
    PrintPreviewDialog preview = new PrintPreviewDialog();
    PrintDocument document = new PrintDocument();
    preview.Document = document;
    document.PrintPage += new PrintPageEventHandler(document_PrintPage);
    preview.ShowDialog(this);
    if (stoppedTimer)
        timer1.Start();
}

```

Since the pen and the two bitmaps need to be disposed, we put them all in one big using block.

You'll need a black pen that's 2 pixels wide to draw the lines around the screenshots.

The bitmaps need to be the same size as the form's drawing area, so ClientSize comes in handy.

The PaintHive() method needs a Graphics object to draw on, so this code creates an empty Bitmap object and passes it to PaintHive().

e.MarginBounds.Width has the width of the printable area of the page. That's how wide the field screenshot should be drawn.

Here's where the height of the screenshot is calculated using the form's height-width ratio.

Here's the code for the Print button. It pauses the simulator (if it's running), creates a PrintDocument, hooks it up to the PrintPage event handler, shows the dialog, and then restarts the simulator.

There's so much more to be done...

You've built a pretty neat little simulator, but why stop now? There's a whole lot more that you can do on your own. Here are some ideas—see if you can implement some of them.

Add a control panel

Convert the constants in the World and Hive classes to properties. Then add a new form with a control panel that has sliders to control them.

Add enemies

Add enemies that attack the hive. The more flowers there are, the more enemies are attracted to the hive. Then add Sting Patrol bees to defend against the enemies and Hive Maintenance bees to defend and repair the hive. Those bees take extra honey.

Add hive upgrades

If the hive gets enough honey, it gets bigger. A bigger hive can hold more bees, but takes more honey and attracts more enemies. If enemies cause too much damage, the hive gets smaller again.

Add a queen bee who lays eggs

The eggs need Baby Bee Care worker bees to take care of them. More honey in the hive causes the queen to lay more eggs, which need more workers to care for them, who consume more honey.

Add animation

Animate the background of the Hive form so the sun slowly travels across the sky. Make it get dark at night, and draw stars and a moon. Add some perspective—make the bees get smaller the further they get from the hive in the field of flowers.

Use your imagination!

Try to think of other ways you can make the simulation more interesting or more interactive.

A good simulation will have lots of tradeoffs, and will give the user ways to decide which tradeoffs to make to influence the progress of the hive.

Did you come up with a cool modification to the simulator? Show off your skills—upload your project's source code to the Head First C# forums at www.headfirstlabs.com/books/hfsharp/.

CAPTAIN AMAZING

THE DEATH OF THE OBJECT

Head First Labs

\$2.98

Chapter
14



Captain Amazing, Objectville's most amazing object, pursues his arch-nemesis...



I'VE GOT YOU NOW, SWINDLER.



YOU'RE TOO LATE! AS WE SPEAK MY CLONE ARMY IS GATHERING IN THE FACTORY BENEATH US...

... READY TO WREAK HAVOC ON THE STREETS OF OBJECTVILLE!

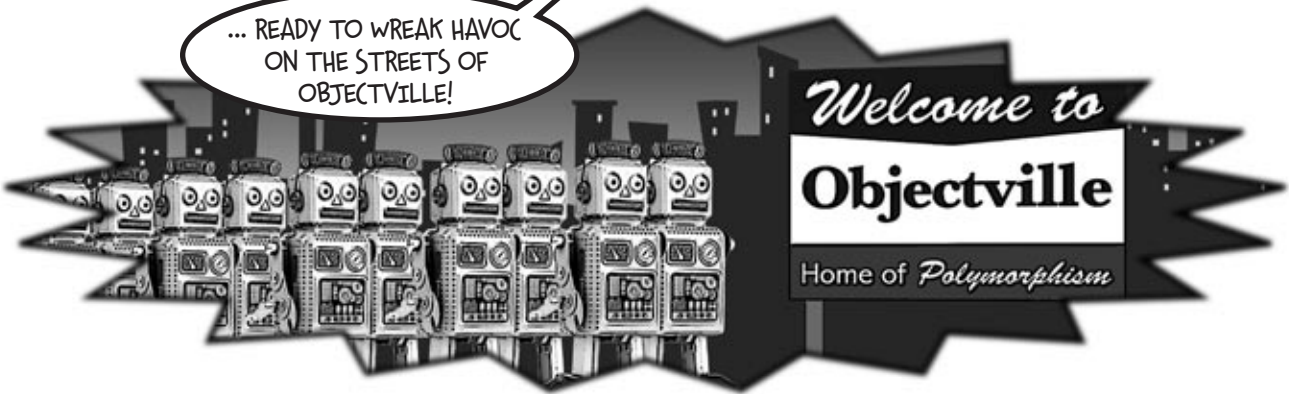

POW!!

I'LL TAKE DOWN EACH CLONE'S REFERENCES, ONE BY ONE.



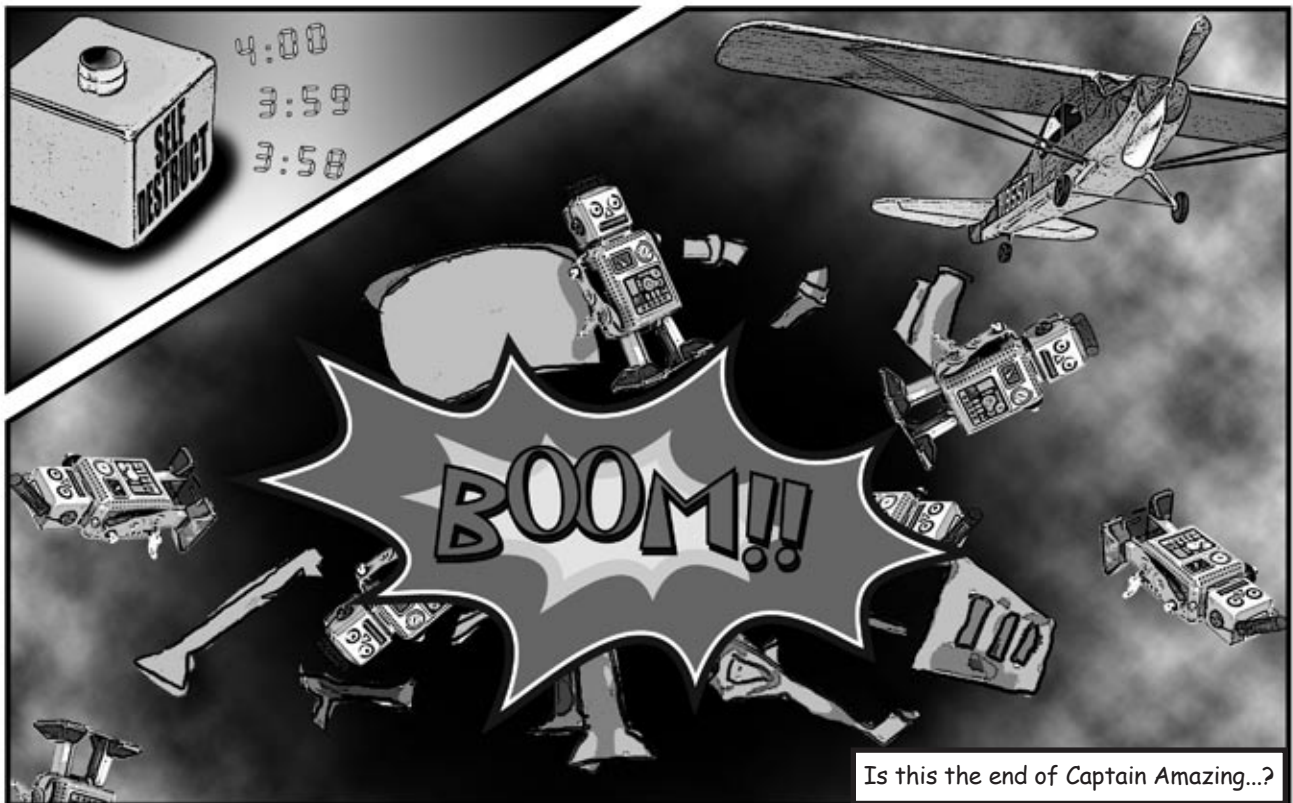
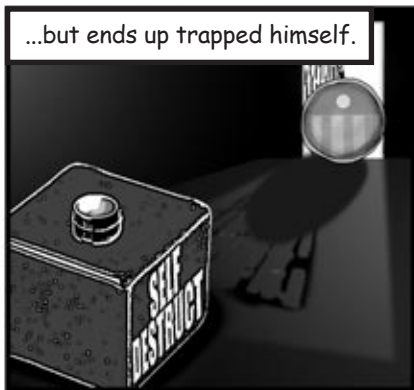
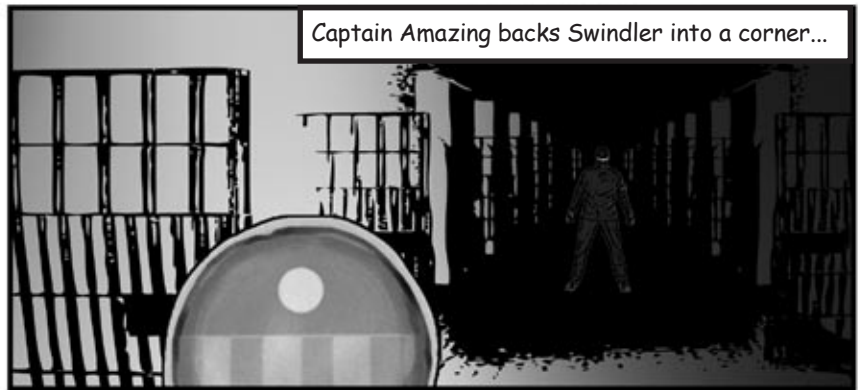



Below is the code detailing the fight between Captain Amazing and Swindler (not to mention his clone army). Your job is to draw out what's going on in memory when the `FinalBattle` class is instantiated.

```
public class FinalBattle {
    public CloneFactory factory = new CloneFactory();
    public List<Clone> Clones = new List<Clone>();
    public SwindlersEscapePlane escapePlane;

    public FinalBattle() {
        public Villain swindler = new Villain(this);
        using (Superhero captainAmazing = new Superhero()) {
            Factory.PeopleInFactory.Add(captainAmazing);
            Factory.PeopleInFactory.Add(swindler); 1
            captainAmazing.Think("I'll take down each of the clones' references,
                one by one");
            captainAmazing.IdentifyTheClones(Clones);
            captainAmazing.RemoveTheClones(Clones);
            swindler.Think("A few minutes from now, you AND my army will be garbage");
            swindler.Think("collected, that is!");
            escapePlane = new SwindlersEscapePlane(swindler); 2
            swindler.TrapCaptainAmazing(Factory);
            MessageBox.Show("The Swindler escaped");
        } 3
    }
}

[Serializable]
public class Superhero : IDisposable {
    private List<Clone> clonesToRemove = new List<Clone>();
    public void IdentifyTheClones(List<Clone> clones) {
        foreach (Clone clone in clones)
            clonesToRemove.Add(clone);
    }
    public void RemoveTheClones(List<Clone> clones) {
        foreach (Clone clone in clonesToRemove)
            clones.Remove(clone);
    }
    ...
}

public class Villain {
    private FinalBattle finalBattle;
    public Villain(FinalBattle finalBattle) {
        this.finalBattle = finalBattle;
    }
    public void TrapCaptainAmazing(CloneFactory factory) {
        factory.SelfDestruct.Tick += new EventHandler(SelfDestruct_Tick);
        factory.SelfDestruct.Interval = 600;
        factory.SelfDestruct.Start();
    }
    private void SelfDestruct_Tick(object sender, EventArgs e) {
        finalBattle.factory = null;
    }
}
```

You can assume that `Clones` was set using an object initializer.

We've gotten you started here, with what's going on in the factory object.

Draw what's going on right here, when the `SwindlersEscapePlane` object is instantiated.

Draw a picture of what the heap will look like exactly one second after the `FinalBattle` constructor runs.

There's more code here (including the `Dispose()` method) that we aren't showing you, but you don't need it to answer this.

```

public class SwindlersEscapePlane {
    public Villain PilotsSeat;
    public SwindlersEscapePlane(Villain escapee) {
        PilotsSeat = escapee;
    }
}

public class CloneFactory {
    public Timer SelfDestruct = new Timer();
    public List<object> PeopleInFactory = new List<object>();
    ...
}

```

There's a clone class and that we're not showing you in this code too. You don't need it to answer the questions.

Make sure you add labels to your objects to show the reference variables that are pointing to them.

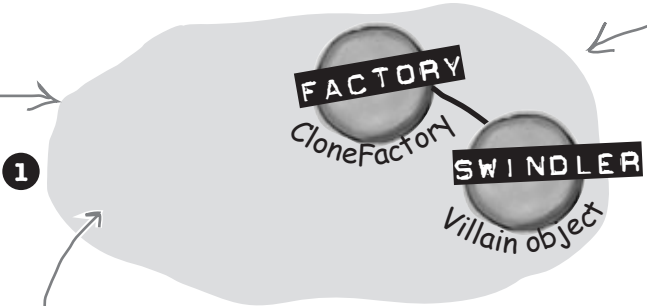

We started the first one for you. Make sure you draw in lines showing the architecture—we drew a line from the clone factory to the Villain object, because the factory has references to it (via its PeopleInFactory field).

We've left space, as there is more to be drawn at this stage.

Don't worry about drawing the Clone and List objects—just add the objects for the Captain, the Swindler, the clone factory, and Swindler's escape plane.



Your job is to draw what's going on in these two bits of memory, too.



Based on your diagrams, where in the code did Captain Amazing die?

.....

.....

.....

.....

Be sure and annotate that on your diagram, too.

hmm... i wonder what those numbers say

Sharpen your pencil Solution

Draw what's happening in memory with the FinalBattle program.

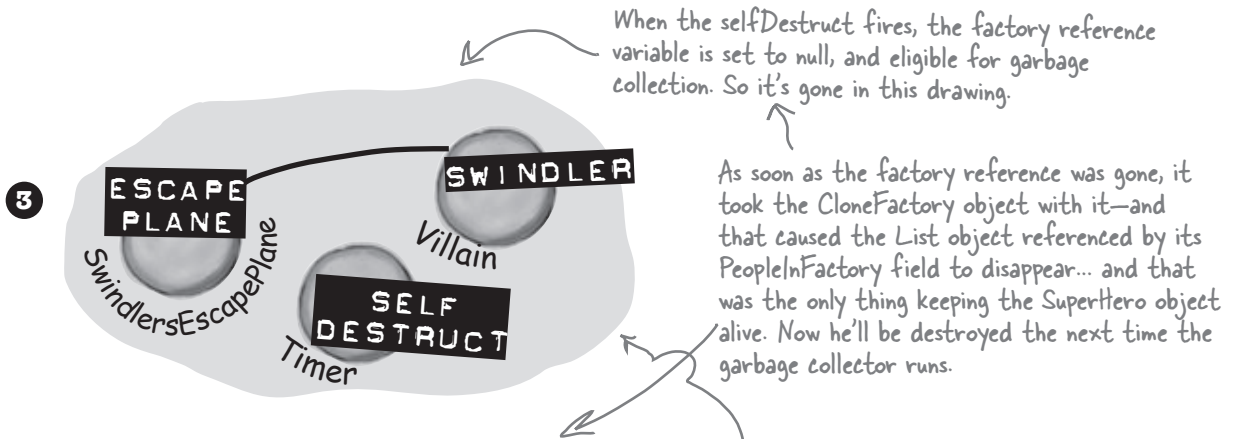
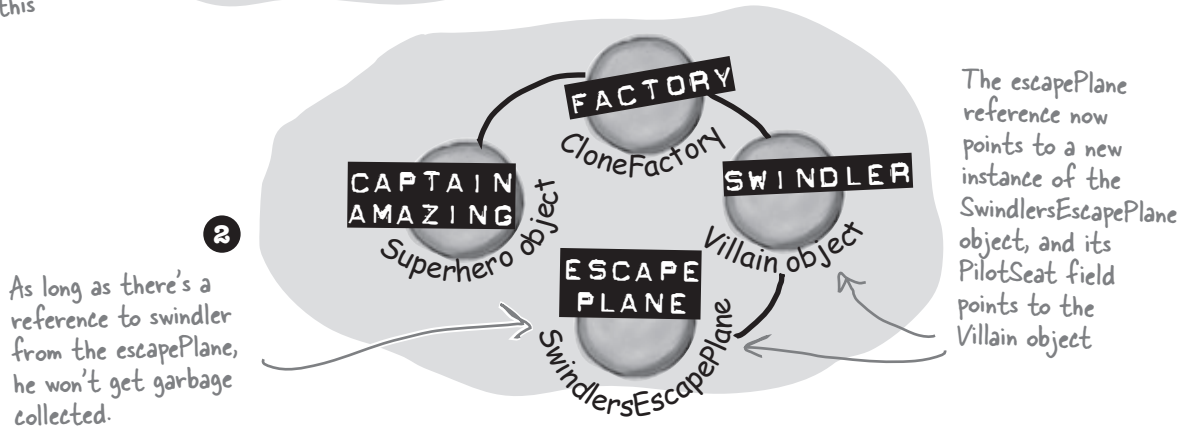
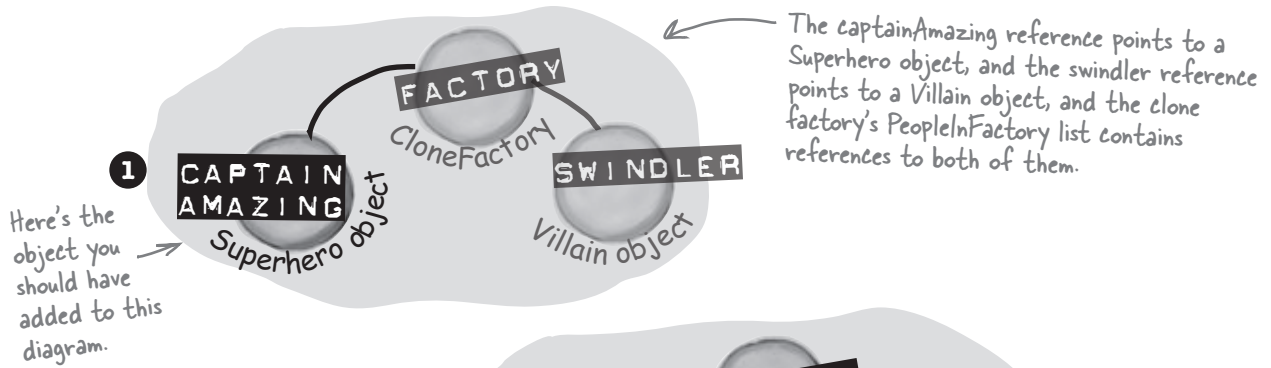

Based on your diagrams, where in the code did Captain Amazing die?

```

void SelfDestruct_Tick(object sender, EventArgs e) {
    finalBattle.factory = null;
}

```

One second after the FinalBattle constructor ran, the hero was gone.

Once finalBattleFactory was set to null, it was ready for garbage collection. And it took the last reference to the Captain with it!

Once the Superhero instance had no clone factory referencing it, it was marked for garbage collection too.

Later, at the funeral home



THE CAPTAIN'S COFFIN IS EMPTY... BUT WHAT'S THIS?

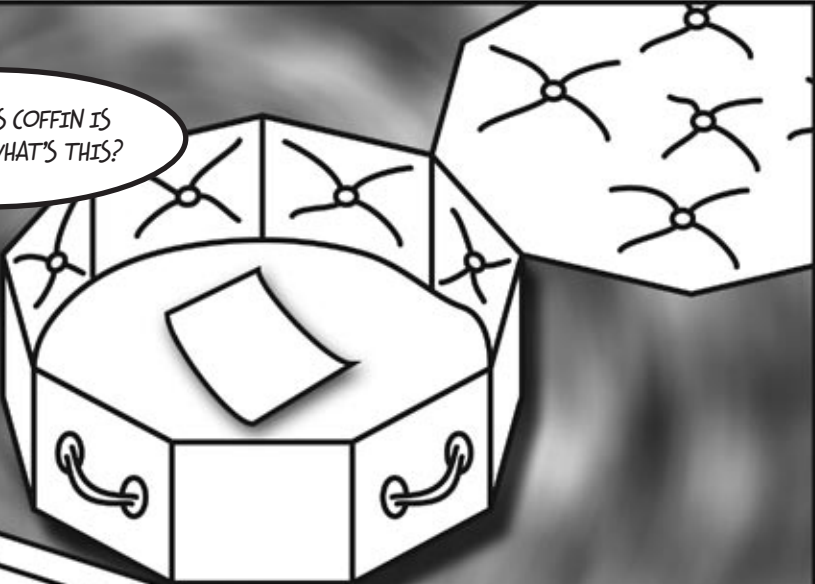

6e 61 6d 65 73 70 61 63 65 20 51 7b 0d 0a 5b 53
65 72 69 61 6c 69 7a 61 62 6c 65 5d 70 75 62 6c
69 63 20 63 6c 61 73 73 20 4d 73 67 7b 0d 0a 70
75 62 6c 69 63 20 73 74 72 69 6e 67 20 61 3b 70
75 62 6c 69 63 20 73 74 72 69 6e 67 20 62 3b 70
75 62 6c 69 63 20 76 6f 69 6e 74 20 69 3b 0d 0a 70 75
62 6c 69 63 20 61 67 65 42 6f 78 2e 53 68 6f 77
7b 4d 65 73 75 62 73 74 72 69 6e 67 28 31 2c 29
28 63 2e 53 75 62 73 74 22 2b 61 2b 63 2b 22 2e 22 2c
29 2b 69 2b 7d 7d 7d 00 01 00 00 00 00 ff ff 01
00 00 00 00 00 00 0c 02 00 00 00 00 38 51 2c 20
56 65 72 73 69 6f 6e 3d 31 2e 30 2e 30 2e 61 6c
20 43 75 6c 74 75 72 65 63 4b 65 79 54 6f 6b 65 6e
2c 20 50 75 62 6c 69 63 01 00 00 05 51 2e 4d 73 67
3d 6e 75 6c 05 01 01 62 01 63 01 69 01 01 01 00
04 00 00 00 06 03 00 00 04 6f 62 6a 65 06
08 02 00 00 03 6e 65 74 06 05 00 00 00 07 63 74
04 00 00 00 00 00 00 00 00 00 00 00 00 00 00
76 69 6c 6c 65 17 00 00 00 00

THAT LOOKS LIKE SOME KIND OF SECRET CODE. DO YOU THINK IT'S FROM THE CAPTAIN?

Your last chance to DO something... your object's finalizer

Sometimes you need to be sure something happens *before* your object gets garbage collected. You might want to release connections or resources... or perhaps send a coded message to the world.

A special method in your object called the **finalizer** allows you to write code that will always execute when your object is destroyed. Think of it as your object's personal **finally** block: it gets executed last, no matter what.

Here's an example of a destructor in the Clone class:

```
[Serializable]
public class Clone {
    string Location;
    int CloneID;

    public Clone (int cloneID, string location){
        this.CloneID = cloneID;
        this.Location = location;
    }

    public void TellLocation(string location, int cloneID){
        Console.WriteLine("My Identification number is {0} and " +
            "you can find me here: {1}.", cloneID, location);
    }

    public void WreakHavoc(){...}

    ~Clone() {
        TellLocation(this.Location, this.CloneID);
        Console.WriteLine ("{0} has been destroyed", CloneID);
    }
}
```

Here's the constructor. It looks like the CloneID and Location fields are populated anytime a Clone gets created.

This ~ (or "tilde") character says that the code in this block gets run when the object is garbage collected.

This is the finalizer. It sends a message to the villain telling the ill-fated clone's location and ID. But it will only run when the object is garbage collected.

You write a finalizer method just like a constructor, but instead of an access modifier, you put a ~ in front of the class name. That tells .NET that the code in the finalizer block should be run any time it garbage collects the object.

Additionally, finalizers can't have parameters, since .NET calls this object, rather than any other object.



Watch it!

Destructors and finalizers are the same thing.

Sometimes you'll hear people refer to an object's Finalizer method, and sometimes to its destructor.

Both of those terms refer to a method that runs when an object is garbage collected. "Finalizer" is generally replacing "destructor" as the name for this. We'll use "destructor" a few times, just because some of the IDE's error messages do.

When EXACTLY does a finalizer run?

The finalizer you build for your object runs when that object gets garbage collected. And garbage collection happens after **all** references to your object go away. But garbage collection doesn't always happen *right after* the references are gone.

Suppose you have an object with a reference to it. .NET sends the garbage collector to work, and it checks out your object. But since there are references to your object, the garbage collector ignores it and moves along. Your object keeps living on in memory.

Then, something happens. That last object holding a reference to *your* object decides to move on. Now, your object is sitting in memory, with no references. It can't be accessed. It's basically a **dead object**.

But here's the thing. **Garbage collection is something that .NET controls**, not your objects. So if the garbage collector isn't sent out again for, say, a few seconds, or maybe even a few minutes, your object still lives on in memory. It's unusable, but it hasn't been garbage collected. **And any finalizer your object has does not (yet) get run.**

Finally, .NET sends the garbage collector out again. Your destructor runs... possibly several minutes after the last reference to the object was removed or changed. Now that it's been finalized, your object is dead, and the collector tosses it away.

You can SUGGEST to .NET that it's time to collect the garbage

.NET does let you **suggest** that garbage collection would be a good idea. **Most times, you'll never use this method, because garbage collection is tuned to respond to a lot of conditions in the CLR and calling it isn't really a good idea.** But just to see how a finalizer works, you could call for garbage collection on your own. If that's what you want to do, just call `GC.Collect()`.

Be careful, though. That method doesn't **force** .NET to garbage collect things immediately. It just says, "Do garbage collection as soon as possible."

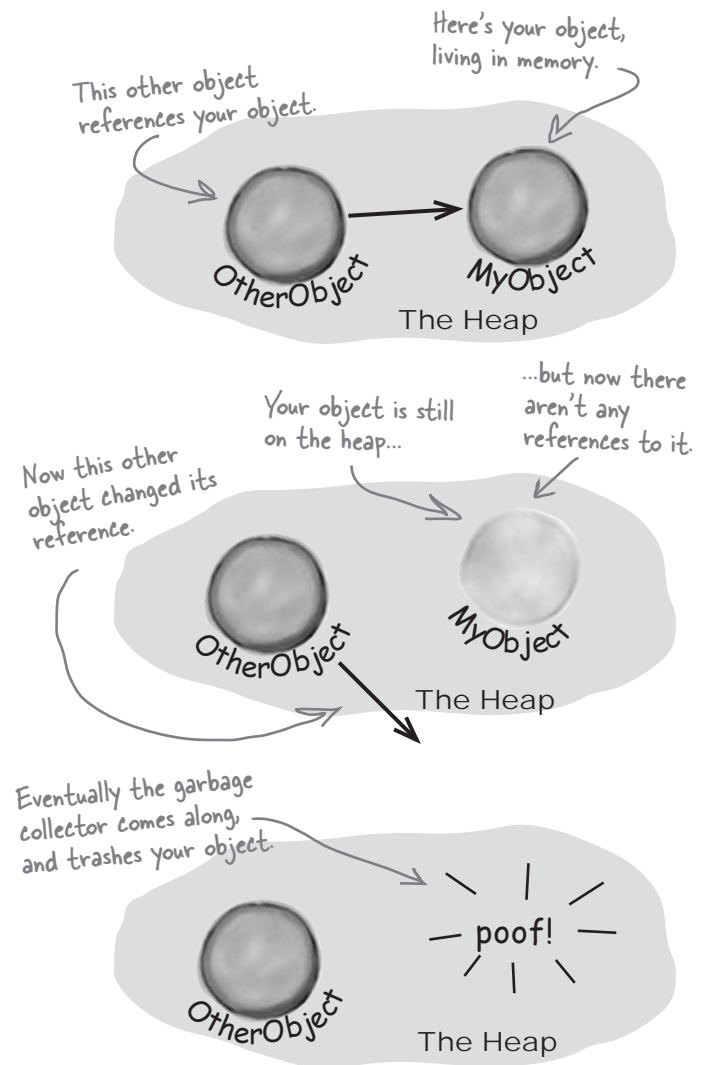

```
public void RemoveTheClones(
    List<Clone> clones) {
    foreach (Clone clone in clonesToRemove)
        clones.Remove(clone);
    GC.Collect();
}
```

Dispose() works with using, finalizers work with garbage collection

Dispose () runs whenever an object that is created in a using statement is set to null or loses all of its references. If you don't use a using statement, then just setting the reference to null won't cause Dispose () to get called—you'll need to call it directly. An object's finalizer runs at garbage collection for that particular object. Let's create a couple of objects, and see how these two methods differ:



1 Create a Clone class and make sure it implements IDisposable.

The class should have one int automatic property called ID. It has a constructor, a Dispose () method and a finalizer:

```
public class Clone : IDisposable {
    public int ID { get; private set; }

    public Clone(int ID) {
        this.ID = ID;
    }

    public void Dispose() {
        MessageBox.Show("I've been disposed!",
            "Clone #" + ID + " says...");
    }

    ~Clone() {
        MessageBox.Show("Aaargh! You got me!",
            "Clone #" + ID + " says...");
    }
}
```

Since the class implements IDisposable, it has to have a Dispose() method.

Here's the finalizer. It will run when the object gets garbage collected.

2 Create a Form with three buttons.

Create one instance of Clone inside the Click handler for the first button with a using statement. Here's the first part of the code for the button:

Here's the form you should create.



The method creates a new Clone and then immediately kills it by taking away its reference.

```
private void clone1_Click(object sender, EventArgs e)
    using (Clone clone1 = new Clone(1)) {
        // Do nothing!
    }
```

Since we declared clone1 with a using statement, its Dispose() method gets run.

As soon as the using block is done and the Clone object's Dispose() method is called, there's no more reference to it and it gets marked for garbage collection.

3 Implement the other two buttons.

Create another instance of Clone in the second button's Click handler, and set it to null manually:

```
private void clone2_Click(object sender, EventArgs e) {
    Clone clone2 = new Clone(2);
    clone2 = null;
}
```

Since this doesn't use a using statement, Dispose() won't ever get run, but the finalizer will.

For the third button, add a call to GC.Collect() to suggest garbage collection occur.

```
private void gc_Click(object sender, EventArgs e) {
    GC.Collect();
}
```

Remember, normally it's not a great idea to do this. But it's fine here, because it's a good way to learn about garbage collection.

4 Run the program and play with Dispose() and finalizers.

Click on the first button and check out the message box: Dispose() runs first.



Even though the Clone1 object has been set to null and its Dispose method has run, it's still on the heap waiting for garbage collection.



In most cases, you *won't* see the garbage collection message box. Because your object is set to null, but garbage collection hasn't run yet.

Now click on the second button... Nothing happens, right? That's because we didn't use a using statement, so no Dispose() method. And until the garbage collector runs, you won't see the message boxes from the finalizer.

Now Clone2 is on the heap, too, but without any references to it.

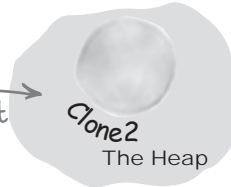

Now click the third button, to suggest garbage collection. You should see the finalizer from both Clone1 and Clone2 fire up and display message boxes.

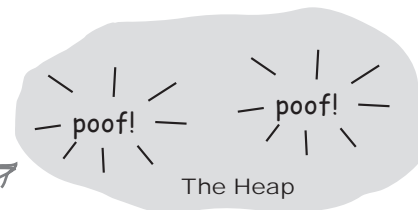

When GC.Collect() is run, both objects run their finalizers and disappear.

Play around with the program. Click the Clone #1 button, then the Clone #2 button, then the GC button. Do it a few times. Sometimes clone #1 is collected first, and sometimes clone #2 is. And once in a while, the garbage collector runs even though you didn't ask it to using GC.Collect().

Finalizers can't depend on stability

When you write a finalizer, you can't depend on it running at any one time. Even if you call `GC.Collect()`—which you should avoid, unless you have a really good reason to do it—you're only **suggesting** that the garbage collector is run. It's not a guarantee that it'll happen right now. And when it does, you have no way of knowing what order the objects will be collected.

So what does that mean, in practical terms? Well, think about what happens if you've got two objects that have references to each other. If object #1 is collected first, then object #2's reference to it is pointing to an object that's no longer there. But if object #2 is collected first, then object #1's reference is invalid. So what that means is that **you can't depend on references in your object's finalizer**. Which means that it's a really bad idea to try to do something inside a finalizer that depends on references being valid.

Serialization is a really good example of something that you **shouldn't do inside a finalizer**. If your object's got a bunch of references to other objects, serialization depends on **all** of those objects still being in memory... and all of the objects they reference, and the ones those objects reference, and so on. So if you try to serialize when garbage collection is happening, you could end up **missing** vital parts of your program because some objects could've been collected **before** the finalizer ran.

Luckily, C# gives us a really good solution to this: `IDisposable`. Anything that could modify your core data or that depends on other objects being in memory needs to happen as part of a `Dispose()` method, not a finalizer.

Some people like to think of a finalizers as a kind of failsafe for the `Dispose()` method. And that makes sense—you saw with your `Clone` object that just because you implement `IDisposable`, that doesn't mean the object's `Dispose()` method will get called. But you need to be careful—if your `Dispose()` method depends on other objects that are on the heap, then calling `Dispose()` from your finalizer can cause trouble. The best way around this is to make sure you **always use a using statement** any time you're creating an `IDisposable` object.

Let's say you've got two objects that have references to each other...

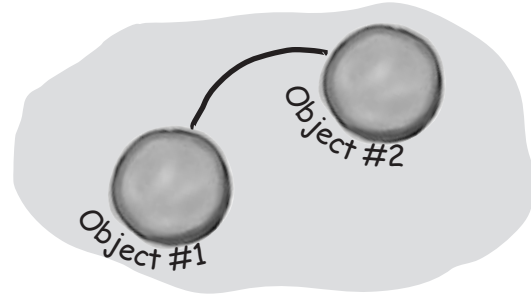

...if they're both marked for garbage collection at the same time, then object #1 could disappear first...

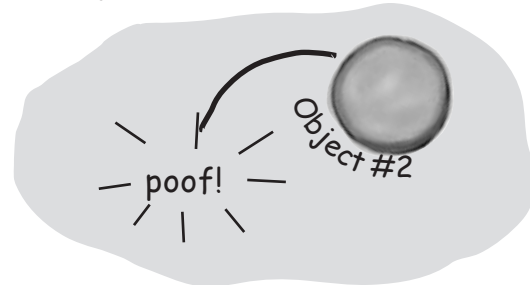

...on the other hand, object #2 could disappear before object #1. You've got no way of knowing the order...

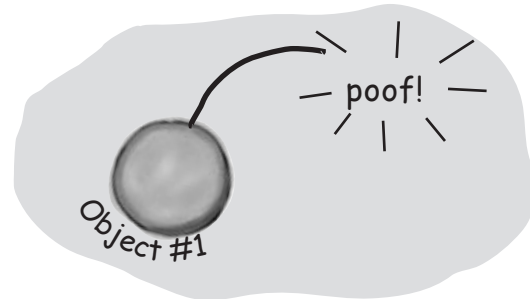

...and that's why one object's finalizer can't rely on any other object still being on the heap.

Make an object serialize itself in its Dispose()

Once you understand the difference between `Dispose()` and a finalizer, it's pretty easy to write objects that serialize themselves out automatically when they're disposed of.



1 Make the Clone class (from page 630) Serializable.

Just add the `Serializable` attribute on top of the class so that we can save the file out.

```
[Serializable]
public class Clone : IDisposable
```

2 Modify Clone's Dispose() method to Serialize itself out to a file.

Let's use a `BinaryFormatter` to write `Clone` out to a file in `Dispose()`:

```
using System.IO;
using System.Runtime.Serialization.Formatters.Binary;

// existing code

public void Dispose() {
    string filename = "C:\\Temp\\Clone.dat";
    string dirname = "C:\\Temp\\";
    if (File.Exists(filename) == false) {
        Directory.CreateDirectory(dirname);
    }
    BinaryFormatter bf = new BinaryFormatter();
    using (Stream output = File.OpenWrite(filename)) {
        bf.Serialize(output, this);
    }
    MessageBox.Show("This is " + this.ID +
        " must.. serialize..object.");
}
```

You'll need a few more using statements to access the I/O classes we'll use.

The Clone will create the C:\Temp directory and serialize itself out to a file called Clone.dat.

We hardcoded the filename—we included them as string literals in the code. That's fine for a small demo program like this, but it's not the most robust design. Can you think of problems this might cause, and how you could avoid them?

3 Run the application.

You'll see the same behavior you saw on the last few pages... but before the `Clone1` object is garbage collected, it's serialized to a file. Look inside the file and you'll see the binary representation of the object.



What do you think the rest of the `SuperHero` object's code looked like? We showed you part of it on page 624. Could you write the rest now?

Fireside Chats



Tonight's talk: **The Dispose method and a finalizer spar over who's more valuable.**

Dispose:

To be honest, I'm a little surprised I was invited here. I thought the programming world had come to a consensus. I mean, I'm way more valuable than you are. Really, you're pretty feeble. You can't even serialize yourself out, alter core data, anything. Pretty unstable, aren't you?

There's an interface specifically **because** I'm so important. In fact, I'm the only method in it!

OK, you're right, programmers need to know they're going to need me and either call me directly or use a using statement to call me. But they always know when I'm gonna run, and they can use me to do whatever they need to do to clean up after their object. I'm powerful, reliable, and easy to use. I'm a triple threat. And you? Nobody knows exactly when you'll run or what the state of the application will be when you finally do decide to show up.

So there's basically nothing you can do that I can't do. But you think you're a big shot because you run when garbage collection happens.

Finalizer:

Excuse me? That's rich. I'm feeble... OK. Well, I didn't want to get into this, but since we're already stooping this low... at least I don't need an interface to get started. Without `IDisposable`, you're just another useless method.

Right, right... keep telling yourself that. And what happens when someone forgets to use a using statement when they instantiate their object? Then you're nowhere to be found.

Handles are what your programs use when they go around .NET and the CLR and interact directly with Windows. Since .NET doesn't know about them, it can't clean them up for you.

OK, but if you need to do something at the very last moment when an object is garbage collected, there's no way to do it without me. I can free up network resources and windows handles and streams and anything else that might cause a problem for the rest of the program if you don't clean it up. I can make sure that your objects deal with being trashed more gracefully, and that's nothing to sneeze at.

I'll take that over your flash and attitude any day, pal.



there are no Dumb Questions

Q: Can a finalizer use all of an object's fields and methods?

A: Sure. While you can't pass parameters to a finalizer method, you can use any of the fields in an object, either directly or using `this`—but be careful, because if those fields reference other objects, then the other objects may have already been finalized. But you can definitely call other methods in the object being finalized (as long as those methods don't depend on other objects).

Q: What happens to exceptions that get thrown in a finalizer?

A: Good question. It's totally legal to put a `try/catch` block inside a finalizer method. Give it a try yourself. Create a divide by zero exception inside a `try` block in the `Clone` program we just wrote. Catch it and throw up a message box that says "I just caught an exception." right before the "...I've been destroyed." box we'd already written. Now run the program and click on the first button and then the GC button. You'll see both the exception box and the destroyed box pop up. (Of course, it generally a **really bad idea** to pop up message boxes in finalizers for objects that are more than just toys... and those message boxes may never actually pop up.)

Q: How often does the garbage collector run automatically?

A: There's no good answer to that one. It doesn't run on an easily predictable cycle, and you don't have any firm control over it. You can be sure it will be run when your program exits. But if you want to be sure it'll run, you have to use `GC.Collect()` to set it off... and even then, timing is an issue.

Q: How soon after I call `GC.Collect()` will .NET start garbage collection?

A: When you run `GC.Collect()`, you're telling .NET to garbage collect soon as possible. That's **usually** as soon as .NET finishes whatever it's doing. That means it'll happen pretty soon, but you can't actually control when.

Q: If I absolutely need something to run, I put it in a finalizer, right?

A: It's possible that your finalizer won't run. It's possible to suppress finalizers when garbage collection happens. Or the process could end entirely. But as a general rule, your finalizer should run.

Meanwhile, on the streets of Objectville...

CAPTAIN AMAZING...
HE'S BACK!

BUT SOMETHING'S WRONG. HE
DOESN'T SEEM THE SAME... AND
HIS POWERS ARE WEIRD.

CAPTAIN AMAZING TOOK SO LONG
TO GET HERE THAT MR FLUFFY
RESCUED HIMSELF FROM THE TREE...

MEOW!

Later...

Even later...

**Captain Amazing's
Hideout Collection
TOP SECRET**

PUFF... PANT.... UGH!
I'M EXHAUSTED

What's wrong? Why are the
Captain's powers behaving
differently? Is this the end?

A struct looks like an object...

One of the types in .NET we haven't talked about much is the `struct`. `struct` is short for **structure**, and structs look a lot like objects. They have fields and properties, just like objects. And you can even pass them into a method that takes an object type parameter:

```
public struct AlmostSuperhero : IDisposable {
    public int SuperStrength;
    public int SuperSpeed { get; private set; }

    public void RemoveVillain(Villain villain)
    {
        Console.WriteLine("OK, " + villain.Name +
            " surrender and stop all the madness!");
        if (villain.Surrendered)
            villain.GoToJail();
        else
            villain.Kill();
    }

    public void Dispose() { ... }
}
```

Structs can implement interfaces but can't subclass other classes.

A struct can have properties and fields...

...and define methods.

The power of objects lies in their ability to mimic real-world behavior, through inheritance and polymorphism.

..but isn't on the heap

But structs *aren't* objects on the heap. They can have methods and fields, but they can't have finalizers. They also can't inherit from other classes or structs, or have classes or structs inherit from them.

All structs inherit from `System.ValueType`, which in turn inherits from `System.Object`. That's why every struct has a `ToString()` method - it gets it from `Object`. But that's all the inheriting that structs are allowed to do."

structs can't inherit from other objects.

SuperHero

You can mimic a standalone object with a struct, but structs don't stand in very well for complex inheritance hierarchies.

struct

That's why you don't usually find yourself defining your own structs. But that doesn't mean they don't have their uses!

Structs are best used for storing data, but the lack of inheritance and the way they're managed in memory can be a serious limitation.

Values get copied, references get assigned

You already have a sense of how some types are different than others. On one hand you've got **value types** like `int`, `bool`, and `decimal`. On the other hand, you've got **objects** like `List`, `Stream`, and `Exception`. And they don't quite work exactly the same way, do they?

Here's a quick refresher on value types vs. objects.



When you use the equals sign to set one value type variable to another, it **makes a copy of the value**, and afterwards the two variables aren't connected to each other. On the other hand, when you use the equals sign with references, what you're doing is **pointing both references at the same object**.

★ Variable declaration and assignment works the same with value types or object types:

Remember when we said that methods and statements ALWAYS live in classes? Well, it turns out that's not 100% accurate -- they can also live in structs.

```
int howMany = 25;
bool Scary = true;
List<float> temperatures = new List<float>();
Exception ex = new Exception("Does not compute");
```

← `int` and `bool` are value types, `List` and `Exception` are object types.

These are all initialized in the same basic way.

★ Differences creep in when you start to assign values, though. Value types all are handled with copying. Here's an example:

Changing the `fifteenMore` variable has no effect on `howMany`, and vice versa.

```
int fifteenMore = howMany;
fifteenMore += 15;
Console.WriteLine("howMany has {0}, fifteenMore has {1}",
    howMany, fifteenMore);
```

← This line copies the value that's stored in the `fifteenMore` variable into the `howMany` variable and adds 15 to it.

The output here shows that `fifteenMore` and `howMany` are **not** connected:

```
howMany has 25, fifteenMore has 40
```

★ With object assignments, though, you're assigning references, not actual values:

This line sets the `differentList` reference to point to the same object as the `temperatures` reference.

```
temperatures.Add(56.5F);
temperatures.Add(27.4F);
List<float> differentList = temperatures;
differentList.Add(62.9F);
```

Both references point at the same actual object.



So changing the `List` means both references see the update... since they both point to a single `List` object.

```
Console.WriteLine("temperatures has {0}, differentlist has {1}",
    temperatures.Count(), differentList.Count());
```

The output here demonstrates that `differentList` and `temperatures` are actually pointing to the **same** object:

```
temperatures has 3, differentList has 3
```

← When you called `differentList.Add()`, it added a new temperature to the object that both `differentList` and `temperatures` point to.

Structs are value types; objects are reference types

When you create a struct, you're creating a **value type**. What that means is when you use equals to set one struct variable equal to another, you're creating a fresh *copy* of the struct in the new variable. So even though a struct *looks* like an object, it doesn't act like one.



1 Create a struct called Dog

Here's simple struct to keep track of a dog. It looks just like an object, but it's not.

```
public struct Dog {
    public string Name;
    public string Breed;

    public Dog(string name, string breed) {
        this.Name = name;
        this.Breed = breed;
    }

    public void Speak() {
        Console.WriteLine("My name is {0} and I'm a {1}.", Name, Breed);
    }
}
```

Yes, this is not good encapsulation. Bear with us—we're making a point.

2 Create a class called Canine

Make an exact copy of the Dog struct, except replace struct with class and then replace Dog with Canine. Now you'll have a Canine class that you can play with, which is almost exactly equivalent to the Dog struct.

3 Add a button that makes some copies of Dogs and Canines

Here's the code:

```
Canine spot = new Canine("Spot", "pug");
Canine bob = spot;
bob.Name = "Spike";
bob.Breed = "beagle";
spot.Speak();

Dog jake = new Dog("Jake", "poodle");
Dog betty = jake;
betty.Name = "Betty";
betty.Breed = "pit bull";
jake.Speak();
```



4 Before you press that button...

Write down the what you think will be written to the console when you run this code:

.....



What did you think would get written to the console?

My name is Spike and I'm a beagle.

My name is Jake and I'm a poodle.

Here's what happened...

The bob and spot references both point to the same object, so both changed the same fields and accessed the same Speak() method. But structs don't work that way. When you created betty, you made a fresh copy of the data in jake. The two structs are completely independent of each other.

```
Canine spot = new Canine("Spot", "pug"); ①
Canine bob = spot; ②
bob.Name = "Spike";
bob.Breed = "beagle";
spot.Speak(); ③
```

A new Canine object was created and the spot reference points to it.

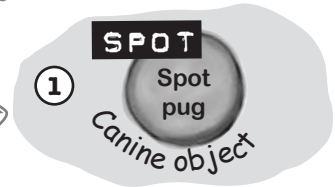

The new reference variable bob was created, but no new object was added to the heap—the bob variable points to the same object as spot.

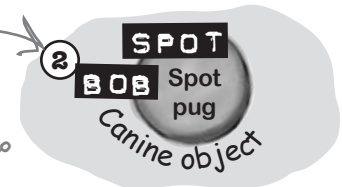

Since spot and bob both point to the same object, spot.Speak() and bob.Speak() both call the same method, and both of them produce the same output with "Spike" and "beagle".

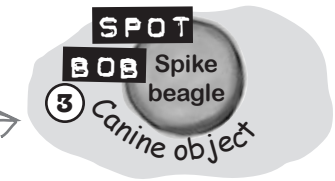

```
Dog jake = new Dog("Jake", "poodle"); ④
Dog betty = jake; ⑤
betty.Name = "Betty";
betty.Breed = "pit bull";
jake.Speak(); ⑥
```

When you create a new struct, it looks really similar to creating an object—you've got a variable that you can use to access its fields and methods.

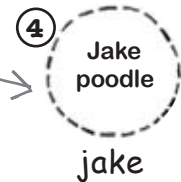

Here's the big difference. When you added the betty variable, you created a whole new struct, even though you didn't use the new keyword.

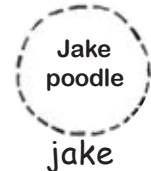
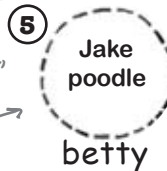

Since you created a fresh copy of the data, jake was unaffected when you changed betty's fields.

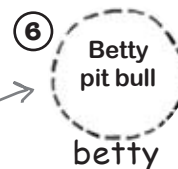

When you set one struct equal to another, you're creating a fresh COPY of the data inside the struct. That's because struct is a VALUE TYPE.

The stack vs. the heap: more on memory

It's easy to understand how a `struct` differs from an object—you can make a fresh copy of a struct just using equals, which you can't do with an object. But what's really going on behind the scenes? The reason structs act like other value types is that **value types don't live on the heap**. The .NET CLR divides your data into two places in memory. You already know that objects live on the **heap**. It also keeps another part of memory called the **stack** to store all of the local variables you declare in your methods, and the parameters that you pass into those methods. You can think of the stack as a bunch of slots that you can stick values in. When a method gets called, the CLR adds more slots to the top of the stack. When it returns, its slots are removed.

Behind the Scenes



Remember, when your program's running, the CLR is actively managing memory, dealing with the heap and collecting garbage.

Even though you can set an object variable equal to a struct, structs and objects are different.

The Code

Here's code that you might see in a program.

```
Canine spot = new Canine("Spot", "pug");
Dog jake = new Dog("Jake", "poodle");
```

Here's what the stack looks like after these two lines of code run.

The Stack

This is where structs and local variables hang out.



```
Canine spot = new Canine("Spot", "pug");
Dog jake = new Dog("Jake", "poodle");
Dog betty = jake;
```

When you create a new struct—or any other value type variable—a new “slot” gets added onto the stack. That slot is a copy of the value in your type.



```
Canine spot = new Canine("Spot", "pug");
Dog jake = new Dog("Jake", "poodle");
Dog betty = jake;
SpeakThreeTimes(jake);
```

```
public SpeakThreeTimes(Dog dog) {
    int i;
    for (i = 0; i < 5; i++)
        dog.Speak();
}
```

When you call a method, the CLR puts its local variables on the top of the stack. It takes them off when it's done.



Wait a minute. Didn't you just say that you can set an object variable equal to a struct? If an object's on the heap, and a struct is on the stack, what happens?



You can also use the "is" keyword to see if an object is a struct, or any other value type, that's been boxed and put on the heap.

When you set an object equal to a value type, it gets boxed.

There are some times that you need to be able to write a method that can take either a value type **or** a reference type—perhaps a method that can work with either a Dog struct or a Canine object. If you find yourself in that situation, you can use the object keyword:

```
public WalkDogOrCanine(object anything) { ... }
```

If you send this method a struct, the struct gets **boxed** into a special object "wrapper" that allows it to live on the heap. While the wrapper's on the heap, you can't do much with the struct. You have to "unwrap" the struct to work with it. Luckily, all of this happens *automatically* when you set an object equal to a value type, or pass a value type into a method that expects an object.

- 1 Here's what the stack and heap look like after you create an object variable and set it equal to a Dog struct.

```
Dog sid = new Dog("Sid", "husky");
Object obj = sid;
```



After a struct is boxed, there are two copies of the data: on the stack, and the copy boxed on the heap.

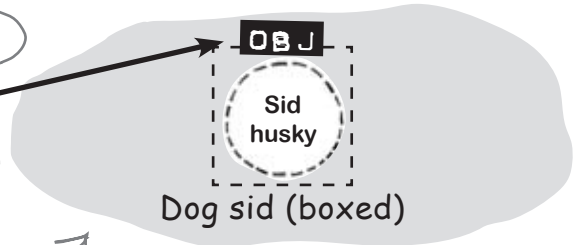

There's a special case where value types don't get boxed: if they live inside an object. If you've got a class with an int field, that int doesn't need to be boxed before it's added to the heap because it's already got a container — the object that it's a part of.

- 2 If you want to unbox the object, all you need to do is cast it to the right type, and it gets unboxed automatically. This is where the is keyword comes in handy.

```
if (obj is Dog)
    Dog happy = (Dog) obj;
```

These are structs, so unless they're boxed, they don't live on the heap.

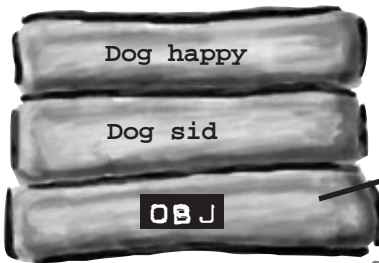

After this line runs, you've got a third copy of the data in a new struct called happy, which gets its own slot on the stack.

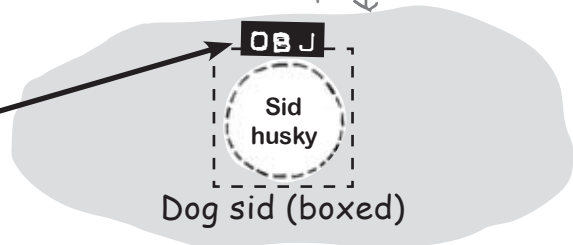

Pool Puzzle



Your **job** is to take snippets from the pool and place them into the blank lines in the code. You **may** use the same snippet more than once, and you won't need to use all the snippets. Your **goal** is to make the code write this output to the console when a **new instance of the Faucet class is created**:

```
public class Faucet {
    public Faucet() {
        Table wine = new Table();
        Hinge book = new Hinge();
        wine.Set(book);
        book.Set(wine);
        wine.Lamp(10);
        book.Garden.Lamp("back in");
        book.Bulb *= 2;
        wine.Lamp("minutes");
        wine.Lamp(book);
    }
}
```

Output when you create a new Faucet object:

back in 20 minutes

Here's the goal... to get this output.

```
public _____ Table {
    public string Stairs;
    public Hinge Floor;
    public void Set(Hinge b) {
        Floor = b;
    }
    public void Lamp(object oil) {
        if (oil ____ int)
            _____.Bulb = (int)oil;
        else if (oil ____ string)
            Stairs = (string)oil;
        else if (oil ____ Hinge) {
            _____ vine = oil ____ _____;
            Console.WriteLine(vine.Table()
                + " " + _____.Bulb + " " + Stairs);
        }
    }
}

public _____ Hinge {
    public int Bulb;
    public Table Garden;
    public void Set(Table a) {
        Garden = a;
    }
    public string Table() {
        return _____.Stairs;
    }
}
```

Bonus points: Circle the lines where boxing happens.

Note: each thing from the pool can be used more than once.

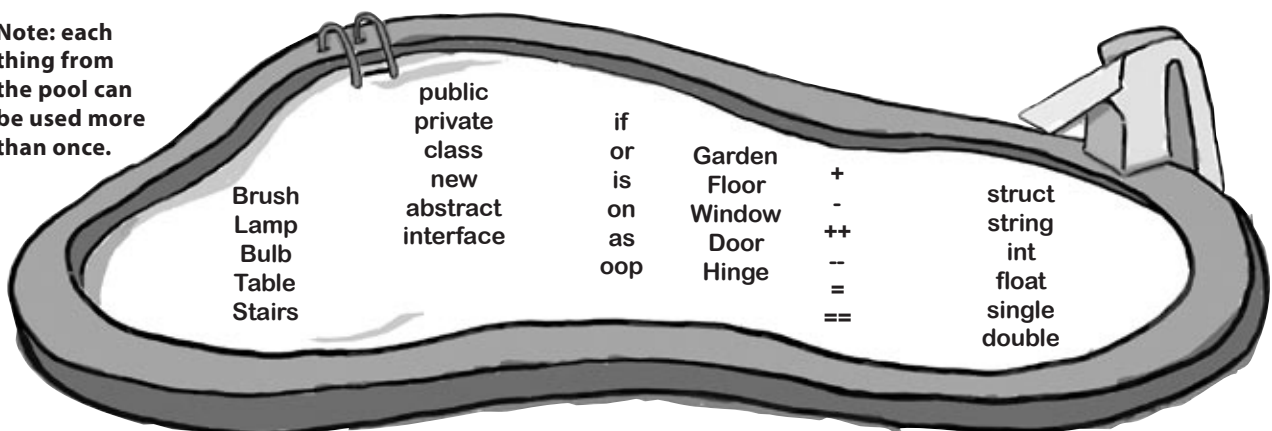

Brush
Lamp
Bulb
Table
Stairs

public
private
class
new
abstract
interface

if
or
is
on
as
oop

Garden
Floor
Window
Door
Hinge

+
-
++
--
=
==

struct
string
int
float
single
double

Answers on page 652.

you are here →

there are no Dumb Questions

Q: Okay, back up a minute. Why do I care about the stack?

A: Because understanding the difference between the stack and the heap helps you keep your reference types and value types straight. It's easy to forget that structs and objects work very differently—when you use the equals sign with both of them, they look really similar. Having some idea of how .NET and the CLR handle things under the hood helps you understand *why* reference and value types are different.

Q: And boxing? Why is that important to me?

A: Because you need to know when things end up on the stack, and you need to know when data's being copied back and forth. Boxing takes extra memory and more time. When you're only doing it a few times (or a few hundred times) in your program, then you won't notice the difference. But let's say you're writing a program that does the same thing over and over again, millions of times a second. That's not too far-fetched, since that's exactly what your beehive simulator did. If you find that your program's taking up more and more memory, or going slower and slower, then it's possible that you can make it more efficient by avoiding boxing in the part of the program that repeats.

Q: I get how you get a fresh copy of a struct when you set one struct variable equal to another one. But why is that useful to me?

A: One place that's really helpful is with **encapsulation**. Take a look at this familiar code from a class that knows its location:

```
private Point location;
public Point Location {
    get { return location; }
}
```

If `Point` were a class, then this would be terrible encapsulation. It wouldn't matter that `location` is private, because you made a public read-only property that returns a reference to it, so any other object would be able to access it.

Lucky for us, `Point` is actually a struct. And that means that the public `Location` property returns a fresh copy of the point. The object that uses it can do whatever it wants to that copy—none of those changes will make it to the private `location` field.

Q: If `Point` is a struct, does that mean there are *other* structs that I've been working with all along?

A: Yes! One struct that's really useful and very common when you're working with graphics and forms is **Rectangle**. It's got some very useful methods that come in really handy when you need to figure out boundaries and check whether points are inside or outside of the rectangle. All you need to do is set its location and size, and it'll automatically compute its top, bottom, left, right, width, and height.

Another useful struct that you'll run into is `Size`. You've already seen it in

action—you used it when you were determining the size of a string using the `MeasureString()` method. It's a struct, too.

Q: How do I know whether to use a struct or a class?

A: Most of the time, programmers use classes. Structs have a lot of limitations that can really make it hard to work with them for large jobs. They don't support inheritance, abstraction, or polymorphism, and you already know how important those things are for building programs easily.

Where structs come in really handy is if you have a small, limited type of data that you need to work with repeatedly. Rectangles and points are good examples—there's not much you'll do with them, but you'll use them over and over again. Structs tend to be relatively small and limited in scope. If you find that you have a small chunk of a few different kinds of data that you want to store in a field in a class or pass to a method as a parameter, that's probably a good candidate for a struct.

A struct can be very valuable when you want to add good encapsulation to your class, because a read-only property that returns a struct always makes a fresh copy of it.

← Pop quiz, hotshot!
Answers on page 646.

Sharpen your pencil



This method is supposed to kill a `Clone` object, but it doesn't work. Why not?

```
private void SetCloneToNull(Clone clone) {
    clone = null;
}
```

.....

.....

Captain Amazing... not so much

With all this talk of boxing, you should have a pretty good idea of what was going on with the less-powerful, more-tired Captain Amazing. In fact, it wasn't Captain Amazing at all, but a boxed struct:

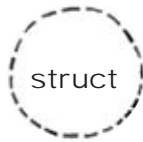

VS.



That's one big advantage of structs (and other value types)—you can easily make copies of them.

1 **Structs can't inherit from classes or implement interfaces**

No wonder the Captain's superpowers seemed a little weak! He didn't get any inherited behavior.

2 **Structs can only live on the heap when they're boxed**

The struct couldn't get onto the heap without being boxed up.

1 **You can't create a fresh copy of an object**

When you set one object variable equal to another, you're copying a *reference* to the *same* variable.

2 **You can use the "as" keyword with an object**

Objects allow for polymorphism by allowing an object to function as any of the objects it inherits from.

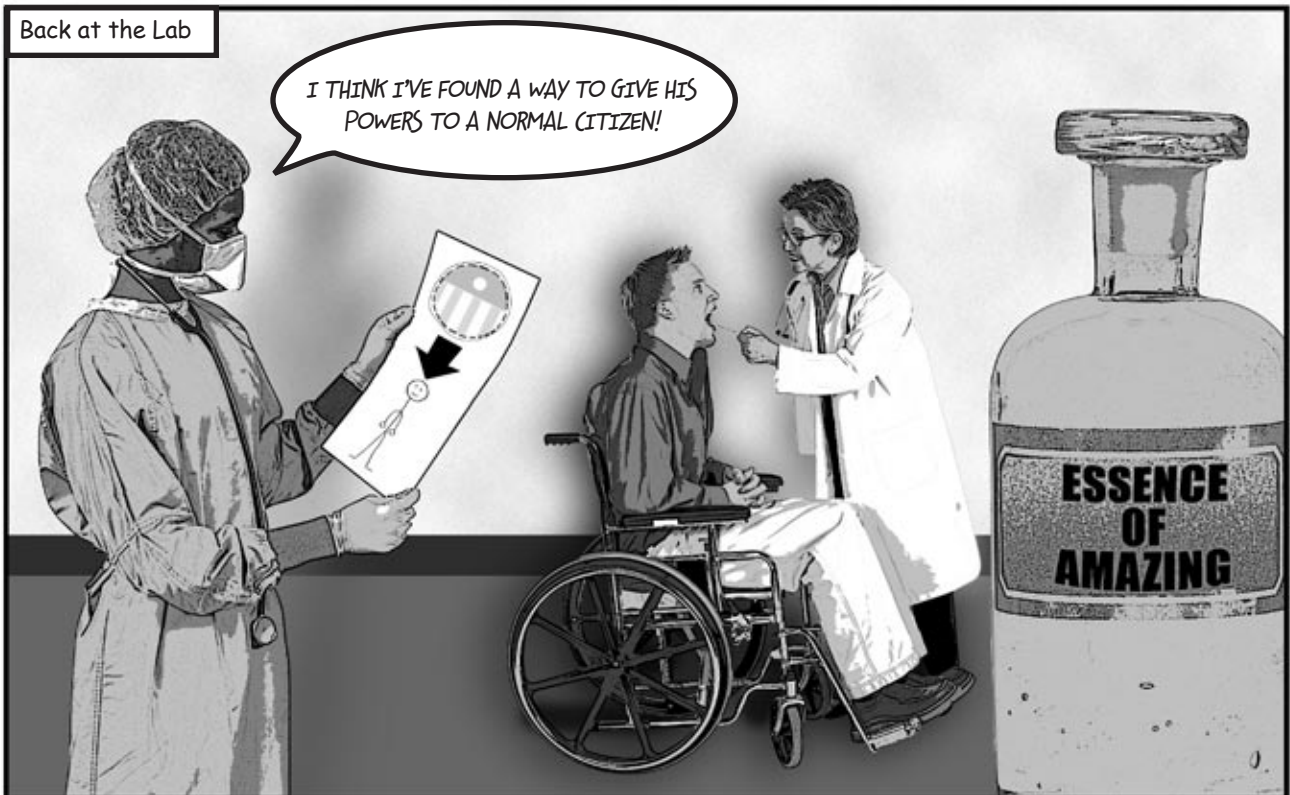

Extension methods add new behavior to EXISTING classes

Remember the sealed access modifier from Chapter 7? It's how you set up a class that can't be extended.

Sometimes you need to extend a class that you can't inherit from, like a sealed class (a lot of the .NET classes are sealed, so you can't inherit from them). And C# gives you a powerful tool for that: **extension methods**. When you add a class with extension methods to your project, it **adds new methods to classes** that already exist. All you have to do is create a static class, and add a static method that accepts an instance of the class as its first parameter using the `this` keyword.

So let's say you've got an OrdinaryHuman class:

```
public sealed class OrdinaryHuman {
    private int age;
    int weight;

    public OrdinaryHuman(int weight) {
        this.weight = weight;
    }

    public void GoToWork() { // code to go to work }
    public void PayBills() { // code to pay bills }
}
```

The OrdinaryHuman class is sealed, so it can't be subclassed. But what if we want to add a method to it?

You use an extension method by specifying the first parameter using the "this" keyword.

Since we want to extend the OrdinaryHuman class, we make the first parameter this OrdinaryHuman.

The SuperSoldierSerum method adds an extension method to OrdinaryHuman:

```
public static class SuperSoldierSerum {
    public static string BreakWalls(this OrdinaryHuman h, double wallDensity) {
        return ("I broke through a wall of " + wallDensity + " density.");
    }
}
```

Extension methods are always static methods, and they have to live in static classes.

As soon as the SuperSoldierSerum class is added to the project, OrdinaryHuman gets a BreakWalls method. So now a form can use it:

```
private void button1_Click(object sender, EventArgs e) {
    OrdinaryHuman steve = new OrdinaryHuman(185);
    Console.WriteLine(steve.BreakWalls(89.2));
}
```

When the form creates an instance of the OrdinaryHuman class, it can access the BreakWalls() method directly—as long as it has access to the SuperSoldierSerum class.



So the clone parameter is just on the stack, so setting it to null doesn't do anything to the heap.

This method is supposed to kill a Clone object, but it doesn't work. Why not?

```
private void SetCloneToNull(Clone clone) {
    clone = null;
}
```

All this method does is set its own parameter to null, but that parameter's just a reference to a Clone. It's like sticking a label on an object and peeling it off again.

there are no
Dumb Questions

Q: Tell me again why I wouldn't add the new methods I need directly to my class code, instead of using extensions?

A: You could do that, and you probably should if you're just talking about adding a method to one class. Extension methods should be used pretty sparingly, and only in cases where you absolutely can't change the class you're working with for some reason (like it's part of the .NET Framework or another third party). Where extension methods really become powerful is when you need to extend the behavior of something you *wouldn't normally have access to*, like a type or an object that comes for free with the .NET framework or another library.

Q: Why use extension methods at all? Why not just extend the class with inheritance?

A: If you can extend the class, then you'll usually end up doing that—extension methods aren't meant to be a replacement for inheritance. But they come in really handy when you've got classes that you can't extend. With extension methods, you can change the behavior of whole groups of objects, and even add functionality to some of the most basic classes in the .NET Framework.

Extending a class gives you new behavior, but requires that you use the new subclass if you want to use that new behavior.

Q: Does my extension method affect all instances of a class, or just a certain instance of the class?

A: It will affect all instances of a class that you extend. In fact, once you've created an extension method, the new method will show up in your IDE alongside of the extended class's normal methods.

Oh, I get it! So you'd use extension methods to add new behavior to one of the built-in .NET Framework classes, right?



Exactly! There are some classes that you can't inherit from.

Pop open any project, add a class, and try typing this:

```
public class x : string { }
```

Try to compile your code—the IDE will give you an error. The reason is that some .NET classes are **sealed**, which means that you can't inherit from them. (You can do this with your own classes, too! Just add the sealed keyword to your class after the `public` access modifier, and no other class will be allowed to inherit from it.) Extension methods give you a way to extend it, even if you can't inherit from it.

But that's not all you can do with extension methods. In addition to extending classes, you can also extend **interfaces**. All you have to do is use an interface name in place of the class, after the `this` keyword in the extension method's first parameter. When you do, the extension method is added to **every class that implements that interface**. Remember that LINQ code you added to your simulator in chapter 12? LINQ was built entirely with extension methods, extending the `IEnumerable` class. (You'll learn a lot more about LINQ in Chapter 15.)

That's another thing you just can't do with inheritance—there's no way to inherit from an interface.

Extending a fundamental type: string

You don't often get to change the behavior of a language's most fundamental types, like strings. But with extension methods, you can do just that! Create a new project, and add a file called `HumanExtensions.cs`.

1 Put all of your extension methods in a separate namespace.

It's a good idea to keep all of your extensions in a different namespace than the rest of your code. That way, you won't have trouble finding them for use in other programs. Set up a static class for your method to live in, too.

```
namespace MyExtensions {
    public static class HumanExtensions {
```

Using a separate namespace is a good organizational tool.

The class your extension method is defined in must be static.

2 Create the static extension method, and defines its first parameter as this and then the type you're extending.

The two main things you need to know when you declare an extension method is that the method needs to be static and have the class it's extending as its first parameter.

```
public static bool IsDistressCall (this string s){
```

"this string" says we're extending the string class.

The extension method must be static, too.

3 Put the code to evaluate the string in the method.

```
public static class HumanExtensions {
    public static bool IsDistressCall(this string s){
        if (s.Contains("Help!"))
            return true;
        else
            return false;
    }
}
```

This checks the string for a certain value... something definitely not in the default string class.

4 Create a form and add a string.

Now go to your form code and add `using MyExtensions;` to the top, and add a button to the form so you can try out your new extension method inside its event handler. Now, when you use a string, you get the extension methods for free. You can see this for yourself by typing the name of a string variable and a period:

```
string message1;
message1 = "An army of clones is wreaking havoc at the factory. Help!";
message1.
```

As soon as you type the dot, The IDE pops up a helper window with all of string's methods... including your extension method.

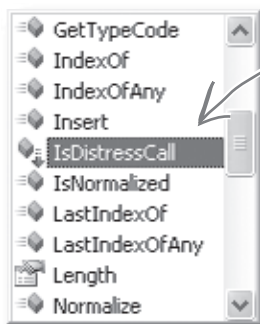

Comment out the using line and the extension method will disappear from the IntelliSense window.

This toy example just shows you the syntax of extension methods. To get a real sense of how useful they are, just wait until the next chapter. It's all about LINQ, which is implemented entirely with extension methods.



Extension Magnets

Arrange the magnets to produce this output:

a buck begets more bucks

```
namespace Upside {
```

```
public static class Margin {
```

```
public static void SendIt
```

```
}
```

```
public static string ToPrice
```

```
}
```

```
namespace Sideways {
using Upside;
```

```
public static class Ticker {
```

```
}
```

```
}
```

```
}
```

```
}
```

```

        s.SendIt();
        i = 3;
        bool b = true;
        Console.Write(s);
        if (b == true)
            return "be";
        else
            return " more bucks";
        (this string s) {
            b.Green().SendIt ();
        }
        (this int n) {
            if (n == 1)
                return "a buck ";
            b.Green().SendIt ();
            .SendIt();
        }
        i.ToPrice()
        (this bool b) {
            int i = 1;
        }
        public static void Main () {
            string s = i.ToPrice();
            return "gets";
        }
    
```



Extension Magnets

Your job was to arrange the magnets to produce this output:

a buck begets more bucks

The Upside namespace has the extensions. The Sideways namespace has the entry point.

The Margin class extends string by adding a method called SendIt() that just writes the string to the console, and it extends int by adding a method called ToPrice() that returns "a buck" if the int's equal to 1, or "more bucks" if it's not.

The entry point method uses the extensions that you added in the Margin class.

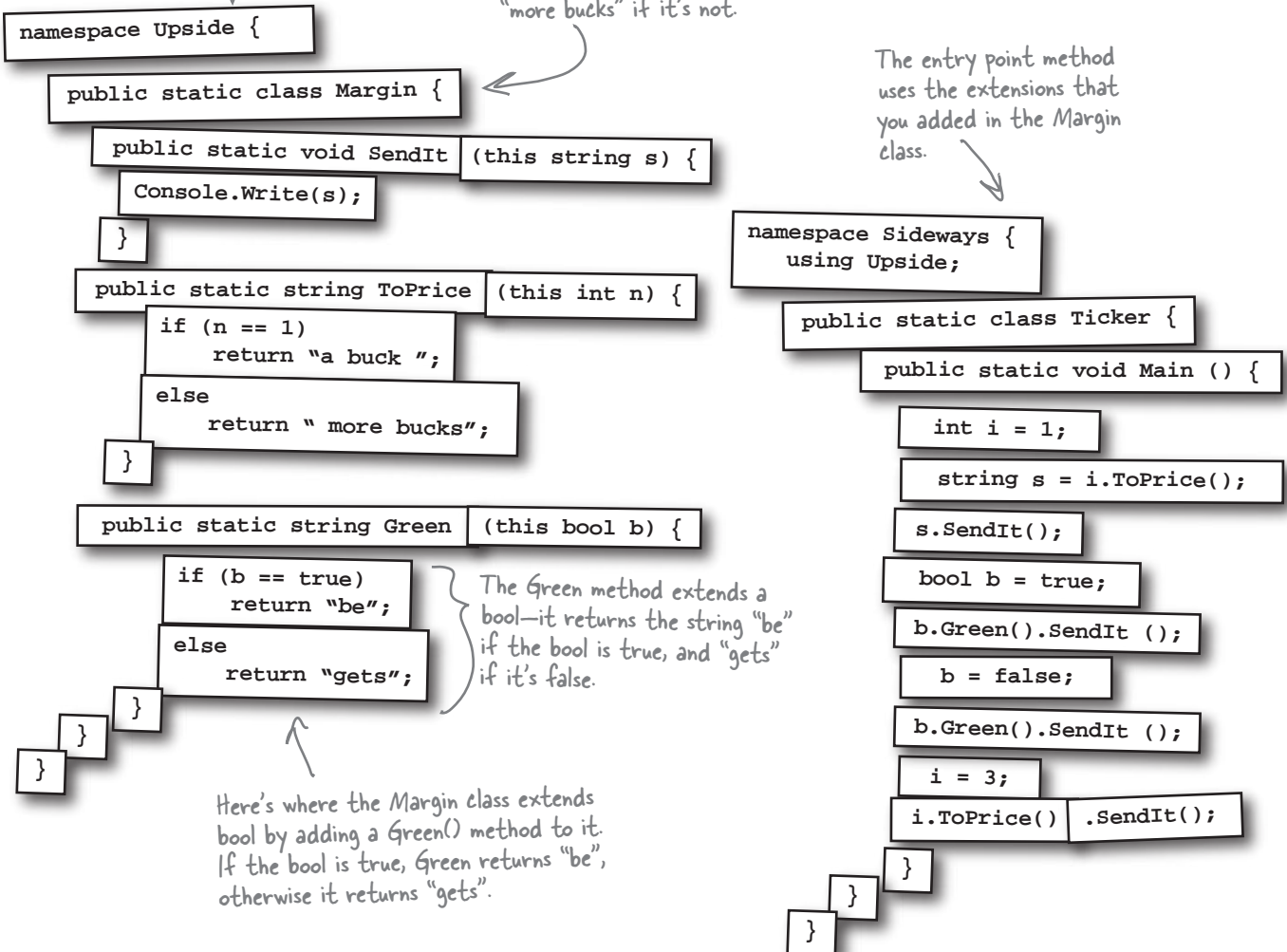

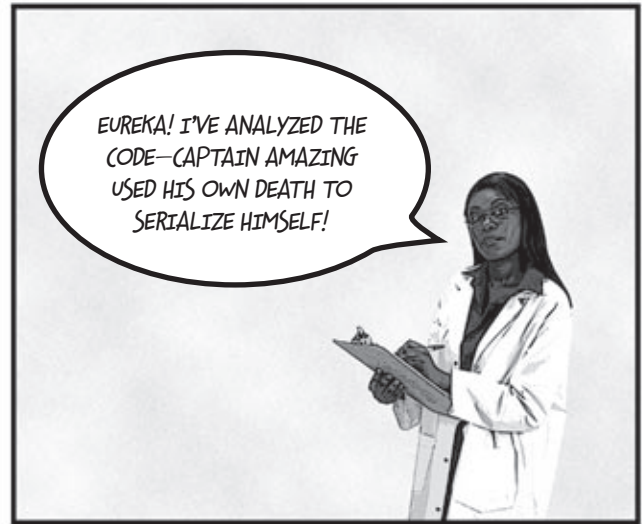

*The*UNIVERSE

CAPTAIN AMAZING REBORN

Death was not the end!

By Bucky Barnes
UNIVERSE STAFF WRITER

OBJECTVILLE

Captain Amazing deserializes himself, makes stunning comeback

In a stunning turn of events, Captain Amazing has returned to Objectville. Last month, Captain Amazing's coffin was found empty, and only a strange note left where his body should have been. Analysis of the note revealed Captain Amazing's object DNA—all his last fields and values, captured faithfully in binary format.

Today, that data has sprung to life. The Captain is back, deserialized from his own brilliant note. When asked how he conceived of such a plan, the Captain merely shrugged and mumbled, "Chapter 9." Sources close to the Captain refused to comment on the meaning of his cryptic reply, but did admit that prior to his failed assault on Swindler, the Captain has spent a lot of time reading books, studying Dispose methods and persistence. We expect Captain Amazing...

...see AMAZING on A-5



Captain Amazing is back!

Pool Puzzle Solution



The Lamp() method sets the various strings and ints. If you call it with an int, then it sets the Bulb field in whatever object Hinge points to.

Output when you create a new Faucet object:
back in 20 minutes

```
public class Faucet {
    public Faucet() {
        Table wine = new Table();
        Hinge book = new Hinge();
        wine.Set(book);
        book.Set(wine);
        wine.Lamp(10);
        book.Garden.Lamp("back in");
        book.Bulb *= 2;
        wine.Lamp("minutes");
        wine.Lamp(book);
    }
}
```

Here's why Table has to be a struct. If it were a class, then wine would point to the same object as book.Garden, which would cause this to overwrite the "back in" string.

Bonus question: Circle the lines where boxing happens.

Since the Lamp() method takes an object parameter, boxing automatically happens when it's passed an int or a string.

```
public struct Table {
    public string Stairs;
    public Hinge Floor;
    public void Set(Hinge b) {
        Floor = b;
    }
    public void Lamp(object oil) {
        if (oil is int)
            Floor.Bulb = (int)oil;
        else if (oil is string)
            Stairs = (string)oil;
        else if (oil is Hinge) {
            Hinge vine = oil as Hinge;
            Console.WriteLine(vine.Table()
                + " " + Floor.Bulb + " " + Stairs);
        }
    }
}
```

If you pass a string to Lamp, it sets the Stairs field to whatever is in that string.

Remember, the as keyword only works with classes, not structs.

```
public class Hinge {
    public int Bulb;
    public Table Garden;
    public void Set(Table a) {
        Garden = a;
    }
    public string Table() {
        return Garden.Stairs;
    }
}
```

Both Hinge and Table have a Set() method. Hinge's Set() sets its Table field called Garden, and Table's Set() method sets its Hinge field called Floor.

Get control of your data

So if you take the first word from this article, and the second word in that list, and add it to the fifth word over here... you get secret messages from the government!



It's a data-driven world... you better know how to live in it.

Gone are the days when you could program for days, even weeks, without dealing with **loads of data**. But today, **everything is about data**. In fact, you'll often have to work with data from **more than one place**... and in more than one format. Databases, XML, collections from other programs... it's all part of the job of a good C# programmer. And that's where **LINQ** comes in. LINQ not only lets you **query data** in a simple, intuitive way, but it lets you **group data**, and **merge data from different data sources**.

An easy project...

Objectville Paper Company wants to do a cross-promotion with Starbuzz Coffee. Starbuzz has a frequent customer program where they know who buys which drink and how often they buy it. Objectville Paper wants to figure out **which of their customers are also Starbuzz regulars** and send them a free mug and a coupon for their favorite coffee drink... and it's up to you to combine the data and generate the list of customers to send mugs and coupons to.



...but the data's all over the place

Starbuzz keeps all their data in classes, grouped together in a big `List`. But the Objectville data is in a database (from way back in Chapter 1). We want to find any Starbuzz customers who spent more than \$90, match them to the Objectville Paper contact list, and make a final list of people: **we want each person's name, the company they work for, and their favorite Starbuzz drink.**

The Starbuzz data's in a `List<>`

The Starbuzz people provided a program that connects to their website and pulls all the data into a `List` of `StarbuzzData` class.



You need to get the list of Starbuzz data, and find the customers that match Objectville customers.

Here's the class and enum from Starbuzz's code.

```
public class StarbuzzData
{
    public string Name { get; set; }
    public Drink FavoriteDrink { get; set; }
    public int MoneySpent { get; set; }
    public int Visits { get; set; }
}

public enum Drink {
    BoringCoffee,
    ChocoRockoLatte,
    TripleEspresso,
    ZestyLemonChai,
    DoubleCappuccino,
    HalfCafAmericano,
    ChocoMacchiato,
    BananaSplitInACup,
}
```

You've already got the customer data

You built the Objectville Paper Company contact list back in Chapter 1—it's got part of the data you need.



ContactDB
database

All of the Objectville Paper Company customer data is in a database.



How would you combine the data from Starbuzz and Objectville Paper Company data to get a complete contact list?

LINQ can pull data from multiple sources

You used LINQ in the Hive Simulator to track what groups of Bees were doing. You took advantage of the power of LINQ there to write simple queries to pull data out of a collection. LINQ can work with the Starbuzz data just like it worked with the bees, helping you use queries to pull out customer data. As long as a collection implements the `IEnumerable` interface, you can use LINQ queries with it.

But LINQ also lets you work with more than just collections. You can use the same queries to pull data from a database, or even an XML document. So once we get collections under control, we can use LINQ on the Objectville database.

We gave you Ready Bake Code for the LINQ query in Chapter 12. We'll see exactly how it works in a few pages.

In the simulator, the bees were in a collection.

Here was the query we used in the bee simulator to group and order bees by their state.

```
var beeGroups =
    from bee in world.Bees
    group bee by bee.CurrentState
    into beeGroup
    orderby beeGroup.Key
    select beeGroup;
```

LINQ

We need a similar query to pull data from the Starbuzz customer data, which is also in a collection.

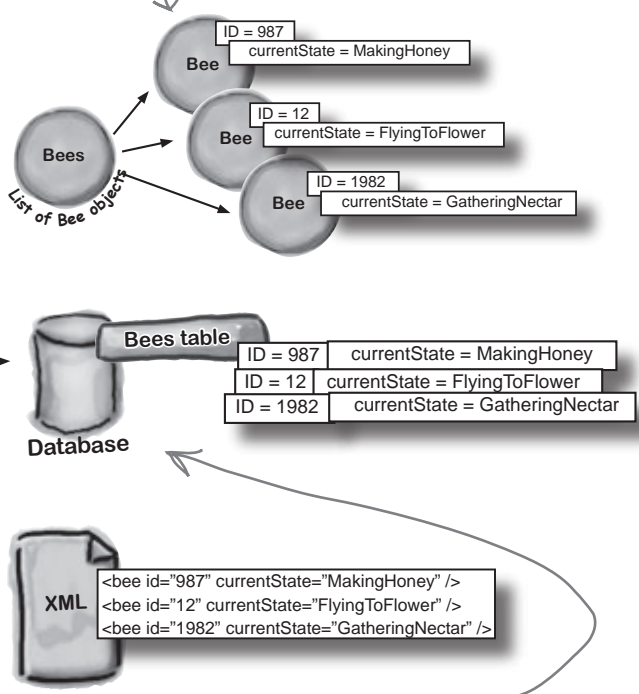

The nice thing about LINQ is that the same query works on a database or XML document, of bees or customers or anything else.

LINQ works with pretty much every kind of data source you could use in .NET. Your code needs a `using System.Linq;` at the top of your file, but that's it. Even better, the IDE automatically puts a reference to LINQ in the header of any code files that are created in Visual Studio 2008. So if you're using Visual Studio 2008 or later, just start coding, and LINQ is available to you.

.NET collections are already set up for LINQ

All of the collection types in .NET implement the `IEnumerable` interface. Type `System.Collections.Generic.IEnumerable<int>` into your IDE window, right-click on the line, and select `Go To Definition`. You'll see that the `IEnumerable` interface defines a `GetEnumerator()` method:

```
namespace System.Collections.Generic {
    public interface IEnumerable<T>: IEnumerable {
        // Summary:
        //     Returns an enumerator that iterates through the collection.
        //
        // Returns:
        //     A System.Collections.Generic.IEnumerator<T> that can be
        //     used to iterate through the collection.
        IEnumerator<T> GetEnumerator();
    }
}
```

All collections and arrays implement `IEnumerable`. Many of them do it by implementing `IEnumerable<T>`, which inherits from `IEnumerable`.

This `T` means that `IEnumerable` will work with any object or type.

This is the only method in the interface. Each collection implements this method. You could create your own kind of collection that implemented `IEnumerable` too... And if you did, you could use LINQ with your collection.

This method requires collections to define a way to move through the collection, one element at a time. That's all LINQ requires as a prerequisite. If you can move through a list of data, item-by-item, LINQ can query the collection.

Behind the Scenes



LINQ uses **extension methods** to let you query, sort, and update data. Check it out for yourself. Create an `int` array called `linqtest`, put some numbers in the array, and then type this line of code (don't worry, you'll learn what it does in a minute):

```
var result = from i in linqtest where i < 3 select i;
```

Now comment out the `using System.Linq;` line up in the header of the file you've created. When you try to rebuild the solution, you'll see that this line doesn't compile anymore. The methods you're calling when you use LINQ are just extension methods that are being used to extend the array.

Now you can see why extension methods were so important in Chapter 14... they let .NET (and you) add all kinds of cool behavior to existing types.

LINQ makes queries easy

Here's a simple example of LINQ syntax. It selects all the numbers in an `int` array that are under 37 and puts those numbers in ascending order. It does that using four **clauses** that tell it what collection to query, what criteria to use to determine which members of the collection to select, how to sort the results, and how the results should be returned.

```
int[] values = new int[] {0, 12, 44, 36, 92, 54, 13, 8};
```

```
var result = from v in values
```

This assigns the letter "v" to stand in for each of the values array in the query. So v is 0, then 12, then 44, then 36... etc.

```
where v < 37
```

This says, select each v in the array that is less than 37.

```
orderby v
```

Then, put those values in order (lowest to highest).

```
select v;
```

If you've used SQL before, it may seem weird to put the select at the end, but that's how things work in LINQ.

```
foreach(int i in result)
```

```
Console.WriteLine(i);
```

Now you can iterate through the results array and print out each item in the LINQ result.

Output:

0, 8, 12, 13, 36

var

`var` is a keyword that tells the compiler to figure out the type of a variable at compilation time. .NET detects the type from the type of the local variable that you're using LINQ to query. When you build your solution, the compiler will replace `var` with the right type for the data you're working with.

In the example above, when this line is compiled:

```
var result = from v in values
```

The compiler replaces "var" with this:

```
IEnumerable<int>
```



Watch it!

LINQ is a new feature that's part of C# 3.0 and Visual Studio 2008.

If you're using an earlier version of C#, take a few minutes to download and install Visual C# 2008 Express Edition. It's free from Microsoft, and it can be installed alongside previous versions.

LINQ is simple, but your queries don't have to be

Jimmy just sold his start-up company to a big investor, and wants to take some of his profits and buy the most expensive issues of Captain Amazing that he can find. But all he's got is data. How can LINQ help him scour his two collections and figure out which comics are the most expensive?

- 1 Jimmy downloaded a list of Captain Amazing issues from a Captain Amazing fan page. He put them in a `List<>` of `Comic` objects that have two fields, `Name` and `Issue`.

```
public class Comic {
    public string Name { get; set; }
    public int Issue { get; set; }
}
```

Jimmy used object initializers and a collection initializer to build his catalog:

```
private static List<Comic> BuildCatalog() {
    List<Comic> comics = new List<Comic>();
    comics.Add(new Comic("Johnny America vs. the Pinko", 6));
    comics.Add(new Comic("Rock and Roll (limited edition)", 19));
    comics.Add(new Comic("Woman's Work", 36));
    comics.Add(new Comic("Hippie Madness (misprinted)", 57));
    comics.Add(new Comic("Revenge of the New Wave Freak (damaged)", 68));
    comics.Add(new Comic("Black Monday", 74));
    comics.Add(new Comic("Tribal Tattoo Madness", 83));
    comics.Add(new Comic("The Death of an Object", 97));
    return comics;
}
```

← Issue #74 of Captain Amazing is called "Black Monday"

- 2 Luckily, there's a thriving marketplace for Captain Amazing comics on Greg's List. He knows that issue #57, "Hippie Madness," was misprinted and the almost all of the run was destroyed by the publisher, and he found a rare copy recently sold on Greg's List for \$13,525. After a few hours of searching, Jimmy was able to build a `Dictionary<>` that mapped issue numbers to values.

```
private static Dictionary<int, int> GetPrices() {
    Dictionary<int, int> values = new Dictionary<int, int>();
    values.Add(6, 3600);
    values.Add(19, 500);
    values.Add(36, 650);
    values.Add(57, 13525);
    values.Add(68, 250);
    values.Add(74, 75);
    values.Add(83, 25);
    values.Add(97, 35);
    return values;
}
```

← Issue #57 is worth \$13,525.



Look closely at the LINQ query on page 658. What do you think Jimmy has to put in his query to find the most expensive issues?



Anatomy of a query

Jimmy could analyze his comic book data with one LINQ query. The `where` clause tells LINQ which items from the collection should be included in the results. But that clause doesn't just have to be a simple comparison. It can include any valid C# statement—like using the `values` dictionary to tell it to return only comics worth more than \$500. And the `orderby` clause works the same way—we can tell LINQ to order the comics by their value.

```
List<Comic> comics = BuildCatalog();
```

```
Dictionary<int, int> values = GetPrices();
```

The LINQ query pulls `Comic` objects out of the `comics` list, using the data in the `values` dictionary to decide which comics to select.

```
var mostExpensive =
```

```
    from comic in comics
```

```
    where values[comic.Issue] > 500
```

```
    orderby values[comic.Issue] descending
```

```
    select comic;
```

The first clause in the query is the `from` clause. This one tells LINQ to query the `comics` collection, and that the name `comic` will be used in the query to specify how to treat each individual piece of data in the collection.

You can choose any name you want when you use a `from` clause. We chose "comic".

The `where` and `orderby` clauses can include ANY C# statement, so we can use the `values` dictionary to select only those comics worth more than \$500 and we can sort the results so the most expensive ones come first.

The name `comic` was defined in the `from` clause specifically so it could be used in the `where` and `orderby` clauses.

```
foreach (Comic comic in mostExpensive)
```

```
    Console.WriteLine("{0} is worth {1:c}",
```

```
        comic.Name, values[comic.Issue]);
```

When you add "`{1:c}`" to the `WriteLine` output, that tells it to print the second parameter in the local currency format.

The query returned its results into a collection called `mostExpensive`. The `select` clause determines what goes into the results—since it selected `comic`, the query returned `Comic` objects.

```
Output
Show output from: Debug
Hippie Madness (misprinted) is worth $13,525.00
Johnny America vs. the Pinko is worth $3,600.00
Woman's Work is worth $650.00
```



I don't buy this. I know SQL already— isn't writing a LINQ query just like writing SQL?

Don't worry if you've never used SQL—you don't need to know anything about it to work with LINQ. But if you're curious, check out "Head First SQL."

LINQ may *look* like SQL, but it doesn't *work* like SQL.

If you've done a lot of work with SQL, it may be tempting to dismiss all this LINQ stuff as intuitive and obvious—and you wouldn't be alone, because a lot of developers make that mistake. It's true that LINQ uses the `select`, `from`, `where`, `ascending`, and `join` keywords, which are borrowed from SQL. But LINQ is very different from SQL, and if you try to think about LINQ the way you think about SQL you'll end up with code that **doesn't do what you expect**.

One big difference between the two is that SQL operates on **tables**, which are very different from **collections**. When you execute a SQL `select` against a table, you can be sure that the table is not going to be updated. SQL has all sorts of built-in data security that you can trust. And SQL queries are set operations, which means they don't examine the rows in the table in any predictable order. A collection, on the other hand, can store *anything*—values, structs, objects, anything—and collections have a specific order. (A table's rows aren't in any particular order until you make a SQL query that orders them; items inside a List, on the other hand, are in order.) And LINQ lets you perform any operation that's supported by whatever happens to be in the collection—it can even call methods on the objects in the collection. And LINQ loops through the collection, which means that it does its operations in a specific order. That may not seem all that important, but if you're used to dealing with SQL, it means your LINQ queries will surprise you if you expect them to act like SQL.

There are a lot of other differences between LINQ and SQL too, but you don't need to understand them in order to work with LINQ successfully. Just approach it with an open mind, and don't expect it to work the way SQL works.

LINQ is versatile

You can do a lot more than just pull a few items out of a collection. You can modify the items before you return them. And once you've generated a set of result collections, LINQ gives you a bunch of methods that work with them. Top to bottom, LINQ gives you the tools you need to manage your data.

★ Modify every item returned from the query

This code will add a string onto the end of each string in an array. It doesn't change the array itself—it **creates a new collection** of modified strings.

```
string[] sandwiches = { "ham and cheese", "salami with mayo",
                        "turkey and swiss", "chicken cutlet" };
var sandwichesOnRye =
    from sandwich in sandwiches
    select sandwich + " on rye";
foreach (var sandwich in sandwichesOnRye)
    Console.WriteLine(sandwich);
```

Notice that all the items returned have "on rye" added to the end.

This adds the string "on rye" to every item in the results from the query.

This change is made to the items in the results of your query... but not to the items in the original collection or database.

Output:

```
ham and cheese on rye
salami with mayo on rye
turkey and swiss on rye
chicken cutlet on rye
```

★ Perform calculations on collections

Remember, we said LINQ adds new methods to your collections (and database access objects)... and some of those are pretty handy on their own, without actual requiring a query:

```
List<int> listOfNumbers = new List<int>();
int length = random.Next(50, 150);
for (int i = 0; i < length; i++)
    listOfNumbers.Add(random.Next(100));

Console.WriteLine("There are {0} numbers",
                 listOfNumbers.Count());
Console.WriteLine("The smallest is {0}",
                 listOfNumbers.Min());
Console.WriteLine("The biggest is {0}",
                 listOfNumbers.Max());
Console.WriteLine("The sum is {0}",
                 listOfNumbers.Sum());
Console.WriteLine("The average is {0:F2}",
                 listOfNumbers.Average());
```

As long as you're using C# 3.0 (which is part of Visual Studio 2008), any collection you create has LINQ capabilities.

None of these methods are part of the .NET collections classes... they're all defined by LINQ.

These are all extension methods defined in the Enumerable class in the System.Linq namespace.



LINQ queries aren't run until you access their results!

It's called "lazy evaluation"—the LINQ query doesn't actually do any looping until a statement is executed that uses the results of the query. That's why `ToList()` is important: it tells LINQ to evaluate the query immediately.

★ Store all or part of your results in a new collection

Sometimes you'll want to keep your results from a LINQ query around. You can use the `ToList()` command to do just that:

```
var under50sorted =
    from number in listOfNumbers
    where number < 50
    orderby number descending
    select number;
```

This time, we're sorting a list of numbers descending, from highest to lowest.

```
List<int> newList = under50sorted.ToList();
```

You can even take just a subset of the results, using the `Take()` method:

```
var firstFive = under50sorted.Take(6);
```

```
List<int> shortList = firstFive.ToList();
foreach (int n in shortList)
    Console.WriteLine(n);
```

`ToList()` converts a LINQ var into a list object, so you can keep results of a query around. There's also `ToArray()` and `ToDictionary()` methods, which do just what you'd expect.

`Take()` pulls out the supplied number of items, from the first of the results from a LINQ query. You can put these into another var, and then convert that into a list.

★ Check out Microsoft's official "101 LINQ Samples" page

There's way more that LINQ can do. Luckily, Microsoft gave you a great little reference to help you along.

<http://msdn2.microsoft.com/en-us/vcsharp/aa336746.aspx>

there are no Dumb Questions

Q: That's a lot of new keywords—from, where, orderby, select... it's like a whole different language. Why does it look so different from the rest of C#?

A: Because it serves a different purpose. Most of the C# syntax was built to do one small operation or calculation at a time. You can start a loop, or set a variable, or do a mathematical operation, or call a method... those are all single operations.

LINQ queries look different because a single LINQ query usually does a whole bunch of things at once. Let's take a closer look at a straightforward query:

```
var under10 =
    from number in numberArray
    where number < 10
    select number;
```

It looks really simple—not a lot of stuff there, right? But this is actually a pretty complex piece of code. Think about what's got to happen for the program to actually select all the numbers from `numberArray` that are less than 10. First, you need to loop through the entire array. Then, each number is compared to 10. Then those results need to be gathered together so your code can use them.

And that's why LINQ looks a little odd: because C# has to cram a whole lot of behavior into a very small space.

LINQ lets you write queries that do very complex things using very little code.



BULLET POINTS

- **from** is how you specify the collection that you're querying. It's always followed by the name of a variable, followed by **in** and the name of the collection (`from value in values`).
- **where** generally follows the `from` clause. That's where you use normal C# conditions to tell LINQ which items to pull out of the collection (`where value < 10`).
- **orderby** lets you order the results. It's followed by the criteria that you're using to sort them, and optionally **descending** to tell it to reverse the sort (`orderby value descending`).
- **select** is how you specify what goes into the results (`select value`).
- **Take** lets you pull the first items out of the results of a LINQ query (`results.Take(10)`). LINQ gives you other methods for each collection: `Min()`, `Max()`, `Sum()`, and `Average()`.
- You can **select** anything—you're not limited to selecting the name that you created in the `from` clause. Here's an example: if your LINQ query pulls a set of prices out of an array of `int` values and names them `value` in the `from` clause, you can return a collection of price strings like this: `select String.Format("{0:c}", value)`.

This is just like the `{0:x}` you used in Chapter 9 when you built the hex dumper. There's also `{0:d}` and `{0:D}` for short and long dates, and `{0:P}` or `{0:Pn}` to print a percent (with *n* decimal places).

there are no Dumb Questions

Q: How does the `from` clause work?

A: It's a lot like the first line of a `foreach` loop. One thing that makes thinking about LINQ queries a little tricky is that you're not just doing one operation. Most C# statements just do one single thing.

A LINQ query does the same thing over and over again for each item in a collection. The `from` clause does two things: it tells LINQ which collection to use for the query, and it assigns a name to use for each member of the collection that's being queried.

The way the `from` clause creates a new name for each item in the collection is really similar to how a `foreach` loop does it. Here's the first line of a `foreach` loop:

```
foreach (int i in values)
```

That `foreach` loop temporarily creates a variable called `i`, which it assigns sequentially to each item in the `values` collection. Now look at a `from` clause in a LINQ query on the same collection:

```
from i in values
```

That clause does pretty much the same thing. It creates a temporary variable called `i` and assigns it sequentially to each item in the `values` collection. The `foreach` loop runs the same block of code for each item in the collection, while the LINQ query applies the same criteria in the `where` clause to each item in the collection to determine whether or not to include it in the results.

Q: How does LINQ decide what goes into the results?

A: That's what the `select` clause is for. Every LINQ query returns a collection, and every item in a collection is of the same type. It tells LINQ exactly what that collection should contain. When you're querying an array or list of a single type—like an array of `ints` or a `List<string>`—it's obvious what goes into the `select` clause. But what if you're selecting from a list of `Comic` objects? You could do what Jimmy did and `select` the whole class. But you could also change the last line of the query to `select comic.Name` to tell it to return a collection of `strings`. Or you could do `select comic.Issue` and have it return a collection of `ints`.



LINQ Magnets

Rearrange the magnets so they produce the output at the bottom of the page.

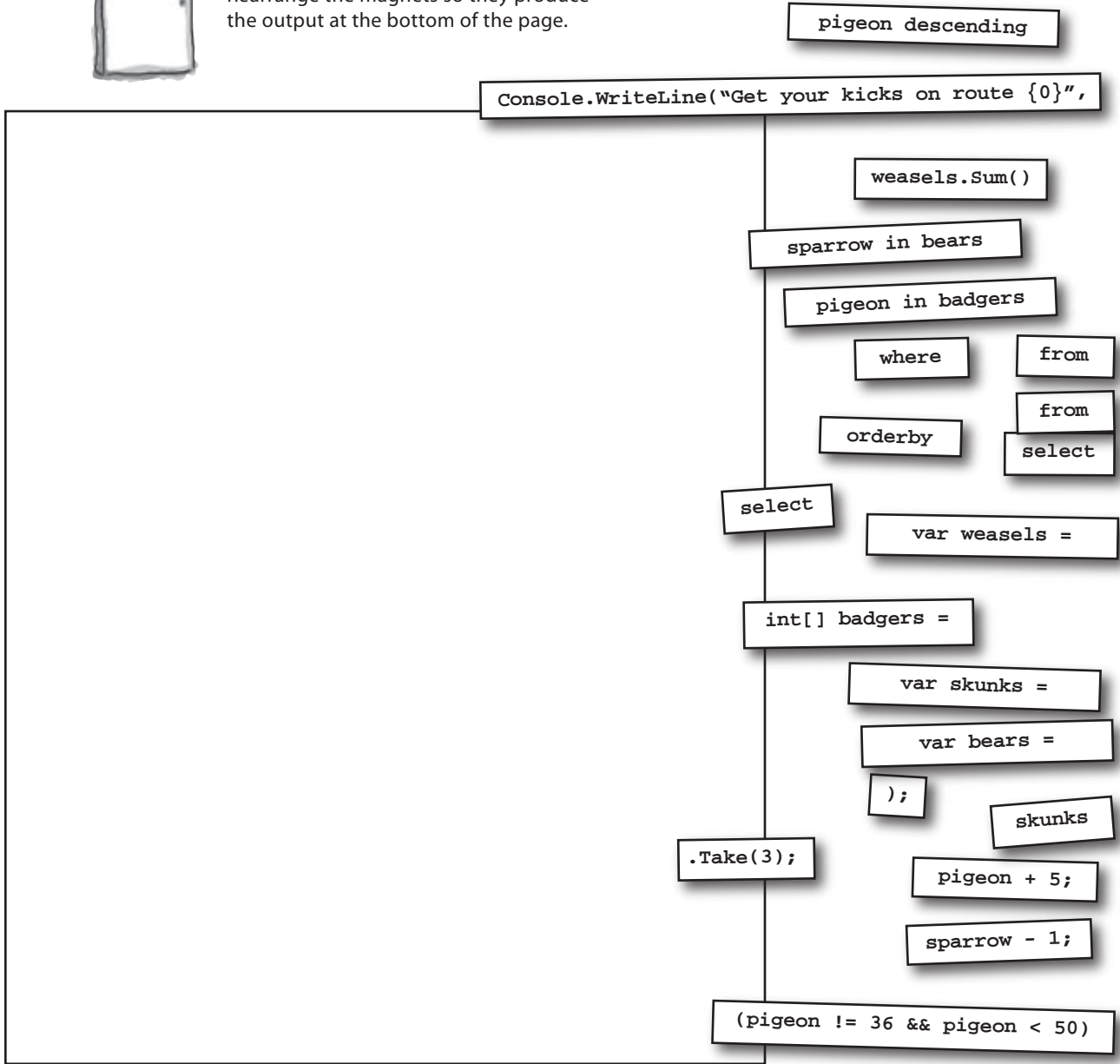

```
Console.WriteLine("Get your kicks on route {0}",
```

```
pigeon descending
```

```
weasels.Sum()
```

```
sparrow in bears
```

```
pigeon in badgers
```

```
where
```

```
from
```

```
orderby
```

```
from  
select
```

```
select
```

```
var weasels =
```

```
int[] badgers =
```

```
var skunks =
```

```
var bears =
```

```
);
```

```
skunks
```

```
.Take(3);
```

```
pigeon + 5;
```

```
sparrow - 1;
```

```
(pigeon != 36 && pigeon < 50)
```

```
{ 36, 5, 91, 3, 41, 69, 8 };
```

Output:
Get your kicks on route 66



LINQ Magnets Solution

Rearrange the magnets so they produce the output at the bottom of the page.

LINQ starts with some sort of collection or array—in this case, an array of integers.

```
int[] badgers = { 36, 5, 91, 3, 41, 69, 8 };
```

"from pigeon in badgers" makes for a good puzzle, but an unreadable LINQ query. "from badger in badgers" is more readable.

After this statement, skunks contains four numbers: 46, 13, 10 and 8.

```
var skunks =
    from pigeon in badgers
    where (pigeon != 36 && pigeon < 50)
    orderby pigeon descending
    select pigeon + 5;
```

This LINQ statement pulls all the numbers that are below 50 and not equal to 36 out of the array, adds 5 to each of them, sorts them from biggest to smallest, and puts them in a new collection called skunks.

After this statement, bears contains three numbers: 46, 13 and 10.

```
var bears =
    skunks.Take(3);
```

Here's where we take the first three numbers in skunks and put them into a new collection called bears.

After this statement, weasels contains four numbers: 45, 12, and 9.

```
var weasels =
    from sparrow in bears
    select sparrow - 1;
```

This statement just subtracts 1 from each number in bears and puts them all into weasels.

```
Console.WriteLine("Get your kicks on route {0}",
    weasels.Sum());
```

$45 + 12 + 9 = 66$

The numbers in weasels add up to 66.

Output:
Get your kicks on route 66

LINQ can combine your results into groups

You already know that you can use LINQ to build your results into groups, because that's what we did with the beehive simulator. Let's take a closer look at that query and see how it works.

```
var beeGroups =
```

```
from bee in world.Bees
```

```
group bee by bee.CurrentState
```

```
into beeGroup
```

```
orderby beeGroup.Key
```

```
select beeGroup;
```

1

The query starts out just like the other queries you've seen—by pulling individual bee objects out of the `world.Bees` collection, a `List<Bee>` object.

2

The next line in the query has a new keyword: **group**. This tells the query to return **groups** of bees. What that means is that rather than returning one single collection, the query will return a **collection of collections**. **group bee by bee.CurrentState** tells LINQ to return one group for each unique `CurrentState` property that it finds in the bees that it selects. Finally, we need to give LINQ a name for the group. That's what the next line is for: **into beeGroup** says that the name "beeGroup" refers to the new groups.

3

Now that we've got groups, we can manipulate them. Since we're returning a collection of groups, we can use the `orderby` keyword to put the groups in order of the `CurrentState` enum values (`Idle`, `FlyingToFlower`, etc.): **orderby beeGroup.Key** tells the query to put the collection of groups in order, sorting them by the group key. Since we grouped the bees by their `CurrentState`, that's what being used as a key.

4

Now we just have to use the `select` keyword to indicate what's being returned by the query. Since we're returning groups, we select the group name: **select beeGroup;**

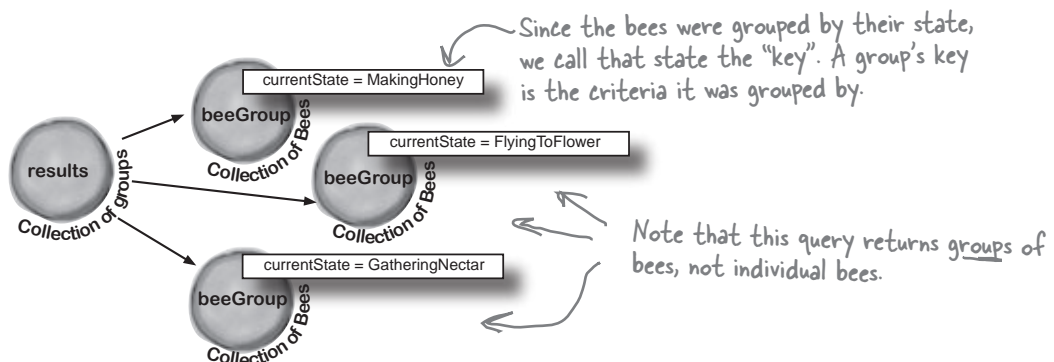

Combine Jimmy's values into groups

Jimmy buys a lot of cheap comic books, some midrange comic books, and a few expensive ones, and he wants to know what his options are before he decides what comics to buy. He's got those prices he got from Greg's List and put into a `Dictionary<int, int>` using his `GetPrices()` method—let's use LINQ to group them into three groups: one for cheap comics that cost under \$100, one for midrange comics that cost between \$100 and \$1000, and expensive ones that cost over \$1000. We'll create a `PriceRange` enum that we'll use as the key for the groups, and a method called `EvaluatePrice()` that'll evaluate a price and return a `PriceRange`.

1 Every group needs a key—we'll use an enum for that

The group's key is the thing that all of its members have in common. The key can be anything: a string, a number, even an object reference. We'll be looking at the prices that Jimmy got from Greg's list. Each group that the query returns will be a collection of issue numbers, and the group's key will be a `PriceRange` enum. And the `EvaluatePrice()` method takes a price as a parameter and returns a `PriceRange`:

```
public enum PriceRange { cheap, midrange, expensive }

public PriceRange EvaluatePrice(int price) {
    if (price < 100) return PriceRange.cheap;
    else if (price < 1000) return PriceRange.midrange;
    else return PriceRange.expensive;
}
```

2 Now we can group the comics by their price categories

The LINQ query returns a **collection of collections**. Each of the collections inside the results has a `Key` property, which matches the `PriceRange` that was returned by `EvaluatePrice()`. Look closely at the `group by` clause—we're pulling pairs out of the `Dictionary`, and using the name `pair` for each of them: `pair.Key` is the issue number, and `pair.Value` is the price from Greg's list. Adding `group pair.Key` tells LINQ to create groups of issue numbers, and then bundles all of those groups up based on the price category that's returned by `EvaluatePrice()`:

```
Dictionary<int, int> values = GetPrices();

var priceGroups =
    from pair in values
    group pair.Key by EvaluatePrice(pair.Value)
    into priceGroup
    orderby priceGroup.Key descending
    select priceGroup;

foreach (var group in priceGroups) {
    Console.WriteLine("I found {0} {1} comics: issues ", group.Count(), group.Key);
    foreach (var price in group)
        Console.WriteLine(price.ToString() + " ");
    Console.WriteLine();
}
```

Each of the groups is a collection, so we added an inner `foreach` loop to pull each of the prices out of the group.

The query figures out which group a particular price belongs to by sending its price to `EvaluatePrice()`. That returns a `PriceRange` enum, which it uses as the group's key.

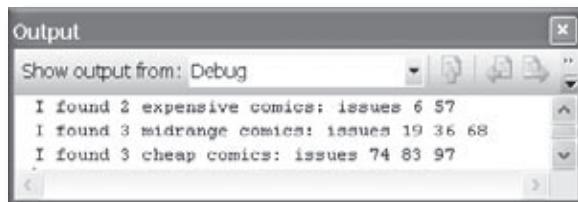

Pool Puzzle



Your **job** is to take snippets from the pool and place them into the blank lines in the program. You can use the same snippet more than once, and you won't need to use all the snippets. Your **goal** is to make the code produce this **output**:

Horses enjoy eating carrots, but they love eating apples.

```
public class Line {
    public string[] Words;
    public int Value;
    public Line(string[] Words, int Value) {
        this.Words = Words; this.Value = Value;
    }
}

Line[] lines = {
    new Line( new string[] { "eating", "carrots,",
        "but", "enjoy", "Horses" }, 1),
    new Line( new string[] { "zebras?", "hay",
        "Cows", "bridge.", "bolted" }, 2),
    new Line( new string[] { "fork", "dogs!",
        "Engine", "and" }, 3 ) ,
    new Line( new string[] { "love", "they",
        "apples.", "eating" }, 2 ) ,
    new Line( new string[] { "whistled.", "Bump" }, 1 ) );
```

Hint: LINQ sorts strings in alphabetical order.

```
var _____ =
    from _____ in _____
    _____ line by line._____
    into wordGroups
    orderby _____ ._____
    select _____;
```

```
_____ = words._____(2);

foreach (var group in twoGroups)
{
    int i = 0;

    foreach (_____ inner in _____) {
        i++;

        if (i == _____.Key) {
            var poem =
                _____ word in _____ ._____
                _____ word descending
                _____ word + ____;

            foreach (var word in _____)
                Console.Write(word);
        }
    }
}
```

Note: each snippet from the pool can be used more once!

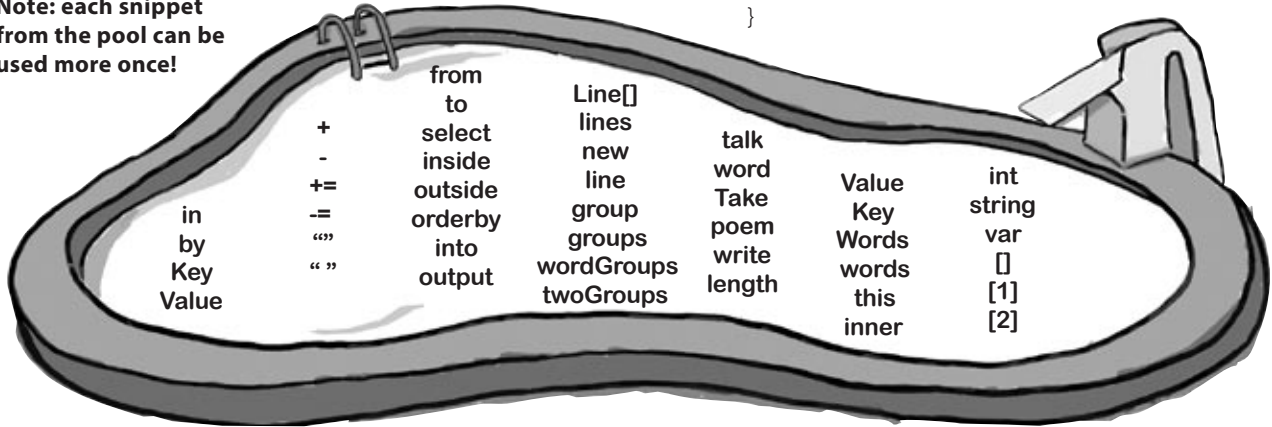

Pool Puzzle Solution



```
public class Line {
    public string[] Words;
    public int Value;
    public Line(string[] Words, int Value) {
        this.Words = Words; this.Value = Value;
    }
}

Line[] lines = {
    new Line( new string[] { "eating", "carrots,", "but", "enjoy", "Horses" }, 1),
    new Line( new string[] { "zebras?", "hay", "Cows", "bridge.", "bolted" }, 2),
    new Line( new string[] { "fork", "dogs!", "Engine", "and" }, 3 ),
    new Line( new string[] { "love", "they", "apples.", "eating" }, 2 ) ,
    new Line( new string[] { "whistled.", "Bump" }, 1 )
};
```

```
var words =
    from line in lines
    group line by line.Value
    into wordGroups
    orderby wordGroups.Key
    select wordGroups;
```

This first LINQ query divides the Line objects in the lines[] array into groups, grouped by their Value, in ascending order of the Value key.

```
var twoGroups = words.Take(2);
```

The first two groups are the lines with Values 1 and 2.

```
foreach (var group in twoGroups)
{
    int i = 0;
    foreach (var inner in group) {
        i++;
        if (i == group.Key) {
            var poem =
                from word in inner.Words
                orderby word descending
                select word + " ";
            foreach (var word in poem)
                Console.Write(word);
        }
    }
}
```

This loop does a LINQ query on the first Line object in the first group and the second Line object in the second group.

Did you figure out that the two phrases "Horses enjoy eating carrots, but" and "they love eating apples" are in descending alphabetical order?

Output: **Horses enjoy eating carrots, but they love eating apples.**

Use join to combine two collections into one query

Jimmy's got a whole collection of comics he's purchased, and he wants to compare them with the prices he found on Greg's List to see if the prices he's been getting are better or worse. He's been tracking his purchases using a `Purchase` class with two automatic properties, `Issue` and `Price`. And he's got a `List<Purchase>` called `purchases` that's got all the comics he's bought. But now he needs to match up the purchases he's made with the prices he found on Greg's List. How's he going to do it?

LINQ to the rescue! Its `join` keyword lets you **combine data from two collections** into a single query. It does it by comparing items in the first collection their matching items in the second collection. (LINQ is smart enough to do this efficiently—it doesn't actually compare every pair of items unless it has to.) The end result is a final result that combines every pair that matches.

- 1 Start off your query with the usual `from` clause. But instead of following it up with the criteria it'll use to determine what goes into the results, you add:

```
join name in collection
```

The `join` clause tells LINQ to loop through both collections to match up pairs of one member from each collection. It assigns `name` to the member it'll pull out of the joined collection in each iteration. You'll use that name in the `where` clause.

Jimmy's got his data in a collection of `Purchase` objects called `purchases`.

```
public class Purchase {
    public int Issue
        { get; set; };
    public int Price;
        { get; set; };
}
```



Jimmy's joining his comics to purchases, a list of comics he's bought.



You've already seen **anonymous types**. When you use an object initializer, you create an anonymous object by typing a series of names and values inside curly brackets.

- 3 You'll continue the LINQ query with `where` and `orderby` clauses as usual. You could finish it with a normal `select` clause, but you usually want to return results that pull some data from one collection and other data from the other. That's where you use `select new` to create a custom set of results using an **anonymous type**.

```
on comic.Issue
equals purchase.Issue
```

The `select new` is followed by curly brackets that contain the data to return in the results.



- 2 Next you'll add the `on` clause, which tells LINQ how to match the two collections together. You'll follow it with the name of the member of the first collection you're matching, followed by `equals` and the name of the member of the second collection to match it to.

```
select new { comic.Name,
             comic.Issue, purchase.Price }
```

Issue = 6	name = "Johnny America"	Price = 3600
Issue = 19	name = "Rock and Roll"	Price = 375
Issue = 57	name = "Hippie Madness"	Price = 13215

Jimmy saved a bunch of dough

It looks like Jimmy drives a hard bargain. He created a list of Purchase classes that contained his purchases, and compared them with the prices he found on Greg's List.

1 First Jimmy created his collection to join.

Jimmy already had his first collection—he just used his BuildCatalog() method from before. So all he had to do was write a FindPurchases() method to build his list of Purchase classes.

```
public List<Purchase> FindPurchases() {
    List<Purchase> purchases = new List<Purchase>() {
        new Purchase() { Issue = 68, Price = 225 },
        new Purchase() { Issue = 19, Price = 375 },
        new Purchase() { Issue = 6, Price = 3600 },
        new Purchase() { Issue = 57, Price = 13215 },
        new Purchase() { Issue = 36, Price = 660 },
    };
    return purchases;
}
```

Jimmy paid \$13,215
for issue #57.

2 Now he could do the join!

You've seen all the parts of this query already... now here they are, put together in one piece.

```
List<Comic> comics = BuildCatalog();
Dictionary<int, int> values = GetPrices();
List<Purchase> purchases = FindPurchases();
var results =
    from comic in comics
    join purchase in purchases
    on comic.Issue equals purchase.Issue
    orderby comic.Issue ascending
    select new { comic.Name, comic.Issue, purchase.Price };
int gregsListValue = 0;
int totalSpent = 0;
foreach (var result in results) {
    gregsListValue += values[result.Issue];
    totalSpent += result.Price;
    Console.WriteLine("Issue #{0} ({1}) bought for {2:c}",
        result.Issue, result.Name, result.Price);
}
Console.WriteLine("I spent {0:c} on comics worth {1:c}",
    totalSpent, gregsListValue);
```

When Jimmy used a join clause, LINQ compared every item in the comics collection with each item in purchases to see which ones have comic.Issue equal to purchase.Issue.

The select new clause creates a result set with Name and Issue from the comic member, and Price from the purchase member.

Jimmy's real happy that he knows LINQ, because it let him see just how hard a bargain he can drive!

```
Output
Show output from: Debug
Issue #6 (Johnny America vs. the Pinko) bought for $3,600.00
Issue #19 (Rock and Roll (limited edition)) bought for $375.00
Issue #36 (Woman's Work) bought for $660.00
Issue #57 (Hippie Madness (misprinted)) bought for $13,215.00
Issue #68 (Revenge of the New Wave Freak (damaged)) bought for $225.00
I spent $18,075.00 on comics worth $18,525.00
```



Okay, so now I know Jimmy played with his comic books using LINQ queries to query his collections... but what about the Starbuzz promotion problem? I still don't see how LINQ works with databases.

Even though LINQ to SQL is very different under the hood, when you write your code it looks really similar to other LINQ queries.

LINQ uses the same syntax with databases as it does with collections.

You've already seen in Chapter 1 how easy .NET makes it to work with a database. The IDE gives you a really convenient way to connect with databases, add tables, and even link data in those tables to your forms.

Now, you can take that same database you already connected to and query it with LINQ. Not only that, LINQ lets you combine your data from your database with data from your objects seamlessly.

In fact, you can use the same exact query syntax... all you need is to get access to your database so you can run a LINQ query against it.

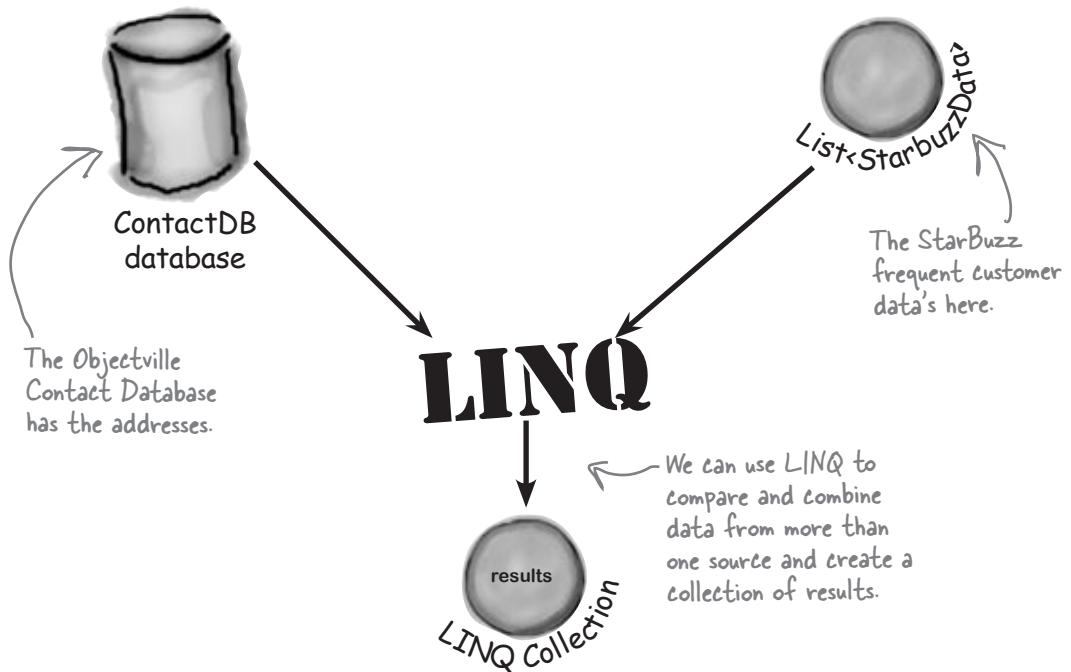

Connect LINQ to a SQL database

LINQ operates on collections that implement the `IEnumerable` interface, right? So it should make sense that you access your SQL database using an object that implements `IEnumerable`. And C# makes it easy to add that object to your project.

Do this

- 1 Add the Objectville Contact Database to a new project**
Back in Chapter 1, you created a database of contacts for the Objectville Paper Company and saved it in a file called `ContactDB.mdf`. Start a new Windows Application project, right-click on your project in the Solution Explorer, select “Add Existing Item” and add the database. Make sure you select “Data Files” from the “Objects of Type” filter list.
- 2 The IDE will pop up the Data Source Configuration Wizard**
Choose the People table by selecting its checkbox. Click Finish—the wizard will create a dataset called `ContactDBDataSet` and add it to your project automatically.

This is the same wizard that you used in Chapter 1 when you first created the database. It adds classes to your project that let you access the database directly.

Take a minute and flip back to Chapter 1 to see how you built it.

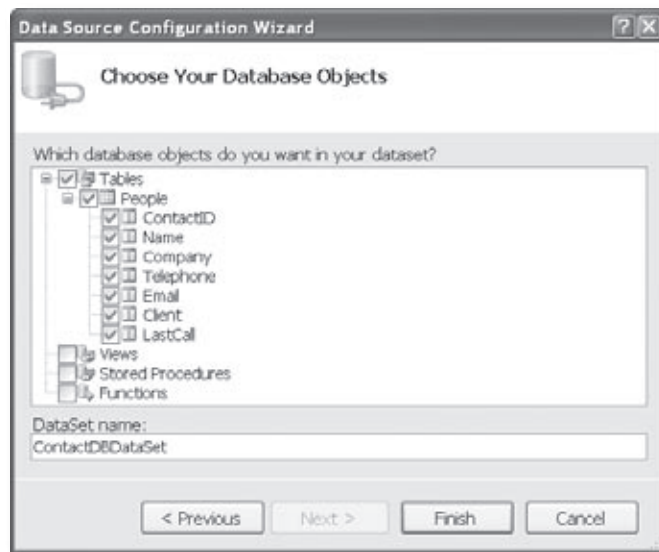

- 3 Add the LINQ to SQL Classes to your project**
Right-click on the project in the Solution Explorer and choose “Add New Item”. It’ll display the familiar list of icons—choose the **LINQ to SQL Classes** and call it `ContactDB.dbml`.



When you add the LINQ to SQL Classes to your project, the IDE automatically adds a collection class to your project that you can use with LINQ.

4 The IDE has a designer to build your SQL collection

As soon as you add the LINQ to SQL Classes to your project, the IDE pops up an empty window called the Object Relational Designer. Here's what it looks like:

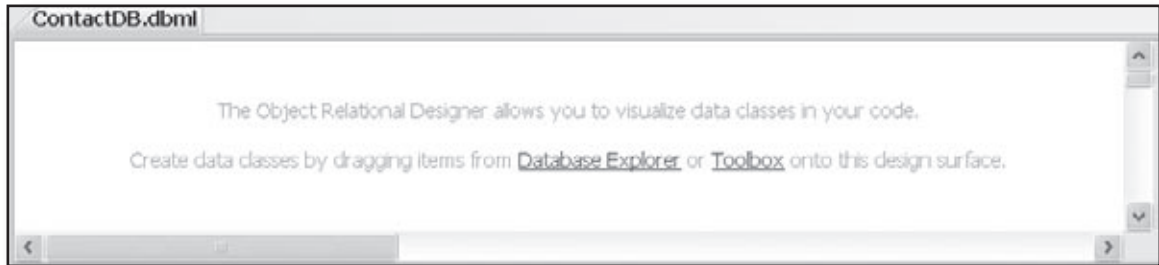

5 Drag the People table to the Object Relational Designer

Click on the [Database Explorer](#) link in the Object Relational Designer window—the IDE will pop up a Database Explorer window. Expand the Tables node, click on the People table icon, drag it into the Object Relational Designer window, and save the project.

The DataContext is a little too smart for its own good. It knows that it's got a People table, so it assumes that the table contains a bunch of rows, one for each "People"... so it has a member called Peoples to contain each individual People.

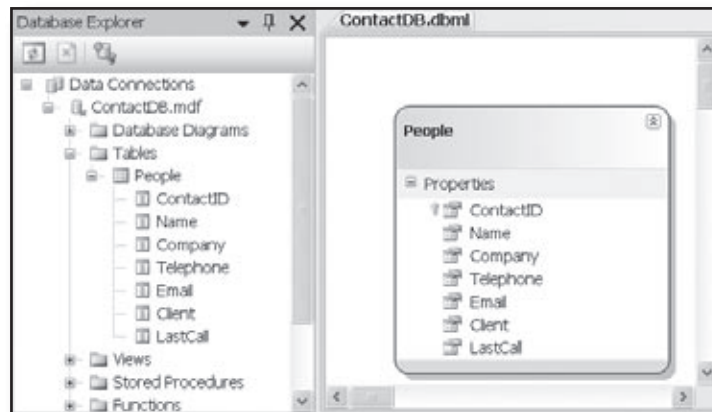

As soon as you save the project, the IDE automatically adds a class called a DataContext to your project—one of its properties is the collection you can query with LINQ, which is connected to the database.

6 You're all set to write LINQ queries that pull data out of the database

Add a button to the form—here's the code for it. Notice how we used the **select new** keyword to create custom results that only contain the Name and Company.

```
ContactDBDataContext context = new ContactDBDataContext();

var peopleData =
    from person in context.Peoples
    select new { person.Name, person.Company };

foreach (var person in peopleData)
    Console.WriteLine("{0} works at {1}", person.Name, person.Company);
```

Get some practice using **select new**. It'll pull just the values from the Name and Company columns from the database.



BULLET POINTS

- The **group** clause tells LINQ to group the results together—when you use it, LINQ creates a collection of group collections.
- Every group contains members that have one member in common, called the group's **key**. Use the **by** keyword to specify the key for the group. Each group collection has a **key** member that contains the group's key.
- Use a **join** clause to tell LINQ to combine two collections into a single query. When you do, LINQ compares every member of the first collection with every member of the second collection, including the matching pairs in the results.
- Join queries use an **on ... equals** clause to tell LINQ how to match the pairs of items.
- When you're doing a join query, you usually want a set of results that includes some members from the first collection and other members from the second collection. The **select new** clause lets you build custom results from both of them.
- LINQ can query a SQL database using the **LINQ to SQL Classes**. Since LINQ only works with collections that implement `IEnumerable`, they provide a collection that lets you access the tables and queries as if they were a collection.
- The IDE's Object Relational Designer lets you choose the tables that you want to access via LINQ. When you specify the tables you want to access, it adds a `DataContext` class to your project. When it's instantiated, add its members to your LINQ queries to access the SQL tables.

there are no Dumb Questions

Q: Can you rewind a minute and explain what `var` is again?

A: Yes, definitely. The `var` keyword solves a tricky problem that LINQ brings with it. Normally, when you call a method or execute a statement, it's absolutely clear exactly what types you're working with. If you've got a method that returns a `string`, for instance, then you can only store its results in a `string` variable or field.

But LINQ isn't quite so simple. When you build a LINQ statement, it usually returns a type that *isn't defined anywhere in your program*. Yes, you know that it's going to be a collection of some sort. But what kind of collection will it be? You don't know—because the objects that are contained in the collection depend entirely on what you put in your LINQ query.

Take this query, for example:

```
var mostExpensive =  
    from comic in comics  
    where values[comic.Issue] > 500  
    select comic;
```

What if you changed the last line to this:

```
select comic.Issue;
```

That's a perfectly valid LINQ query. Instead of returning a collection of `Comic` objects, it'll return a collection of values. And that presents a problem for C#—those are two different types, and we'd have to add extra statements to define those types. So instead, C# gives us the `var` keyword, which tells the compiler, "Okay, we know that this is a valid type, but we can't exactly tell you what it is right now. So why don't you just figure that out yourself and not bother us with it? Thanks so much."

there are no Dumb Questions

Q: I don't quite get how join works.

A: Join works with any two collections. Let's say you've got a collection of football players called `players`—its items are objects that have a `Name` property, a `Position` property and a `Number` property. So we could pull out the players whose jerseys have a number bigger than 10 with this query:

```
var results =
    from player in players
    where player.Number > 10
    select player;
```

Let's say we wanted to figure out each player's shirt size, and we've got a `jerseys` collection whose items have a `Number` property and a `Size` property. A join would work really well for that:

```
var results =
    from player in players
    where player.Number > 10
    join shirt in jerseys
    on player.Number
    equals shirt.Number
    select shirt;
```

Q: Hold on, that query will just give me a bunch of shirts. What if I want to connect each player to his shirt size, and I don't care about his number at all?

A: That's what `select new` is for. It lets you construct an **anonymous type** that only has the data you want in it. And it lets you pick and choose from the various collections that you're joining together, too.

So you can select the player's name and the shirt's size, and nothing else:

```
var results =
    from player in players
    where player.Number > 10
    join shirt in jerseys
    on player.Number
    equals shirt.Number
    select new {
        player.Name,
        shirt.Size
    };
```

The IDE is smart enough to figure out exactly what results you'll be creating with your query. If you create a loop to enumerate through the results, as soon as you type the variable name the IDE will pop up an IntelliSense list.

```
foreach (var r in results)
    r.
```

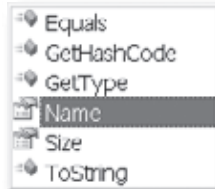

Notice how the list has `Name` and `Size` in it. If you added more items to the `select new` clause, they'd show up in the list too. That's because the query would create a different anonymous type with different members.

Q: But does that only work with joins?

A: Yes, you do. LINQ needs an object that implements the `IEnumerable` interface.

Q: Do I always have to add those LINQ to SQL Classes if I want to use LINQ to query a SQL database? What are they?

A: Yes, you do. LINQ needs an object that implements the `IEnumerable` interface. A SQL database doesn't normally implement that interface... or any interface, really, because it's not an object. So if you want LINQ to work with SQL—or any other source of data that you can query—then you need an object that interacts with it and implements the `IEnumerable` interface.

That's why the IDE provides the LINQ to SQL classes for you. When you add them to your project, they automatically do everything you need in order to connect LINQ to a SQL database: they let you drag database objects into its Object Relational Designer, and when you do, they automatically read your database's tables and create classes (like the `People` class) that LINQ can use to access them.

You can use “select new” to construct custom LINQ query results that include only the items that you want in your result collection.

Use a join query to connect Starbuzz and Objectville

Now you have all the tools that you need to combine the data from Starbuzz and Objectville Paper Company into one final result set.



1 Add the SQL data to your project

If you haven't already done it, create a new Windows application project and add the ContactDB SQL database to it. Then add the LINQ to SQL classes to the project, and write a simple test query just to make sure it's all working.

2 Build the Starbuzz objects

Here's the list that contains the Starbuzz customer data. Add them to your project:

```
public class StarbuzzData { {
    public string Name { get; set; }
    public Drink FavoriteDrink { get; set; }
    public int MoneySpent { get; set; }
    public int Visits { get; set; }
}
public enum Drink {
    BoringCoffee, ChocoRockoLatte, TripleEspresso,
    ZestyLemonChai, DoubleCappuccino, HalfCafAmericano,
    ChocoMacchiato, BananaSplitInACup,
}
```

The Starbuzz data comes as a collection of StarbuzzData objects. It's got a lot of data—you won't need it all for the promotion, so you'll have to select only the data you need in the LINQ query.

Starbuzz has plenty of great drinks, and each customer has his or her favorite.

You'll also need a method to generate some sample data:

```
public List<StarbuzzData> GetStarbuzzData() {
    List<StarbuzzData> list = new List<StarbuzzData>() {
        new StarbuzzData() {
            Name = "Janet Venutian", FavoriteDrink = Drink.ChocoMacchiato,
            MoneySpent = 255, Visits = 50 },
        new StarbuzzData() {
            Name = "Liz Nelson", FavoriteDrink = Drink.DoubleCappuccino,
            MoneySpent = 150, Visits = 35 },
        new StarbuzzData() {
            Name = "Matt Franks", FavoriteDrink = Drink.ZestyLemonChai,
            MoneySpent = 75, Visits = 15 },
        new StarbuzzData() {
            Name = "Joe Ng", FavoriteDrink = Drink.BananaSplitInACup,
            MoneySpent = 60, Visits = 10 },
        new StarbuzzData() {
            Name = "Sarah Kalter", FavoriteDrink = Drink.BoringCoffee,
            MoneySpent = 110, Visits = 15 }
    };
    return list;
}
```

GetStarbuzzData() uses a collection initializer and object initializers to set up the Starbuzz objects.

We built this method so that it has some names that also appear in the Objectville contact list. If you used different names, make sure you've got matching data here.

3 Now join the SQL database to the Starbuzz collection

Add a button to the project that will execute the query and display the results in the console. Here's the code for the query:

```
List<StarbuzzData> starbuzzList = GetStarbuzzData();
ContactDBDataContext context = new ContactDBDataContext();
```

```
var results =
```

Here's where the select new clause pulls the name and company from the database and the favorite drink from the Starbuzz data into one single result collection.

```
    from starbuzzCustomer in starbuzzList
    where starbuzzCustomer.MoneySpent > 90
    join person in context.Peoples
    on starbuzzCustomer.Name equals person.Name
    select new { person.Name, person.Company,
                starbuzzCustomer.FavoriteDrink };
```

We'll need to do a join to combine the Starbuzz data with the customer data in the People table.

The Peoples member in the DataContext is a collection that gives you access to the People table in the database.

and it's easy enough to write to the console:

```
foreach (var row in results){
    Console.WriteLine("{0} at {1} likes {2}",
        row.Name, row.Company, row.FavoriteDrink);
}
```

Check your results—make sure it works the way you expect it to.

Nice work... with this new promotion, I'll bet we'll get tons of repeat business. I'll definitely be calling you again.

Edit queries with LINQPad

There's a great learning tool for exploring and using LINQ. It's called LINQPad, and it's available for free from Joe Albahari (one of our superstar "Head First C#" technical reviewers who kept a lot of bugs out of this book). You can download it here:

<http://www.albahari.com/linqpad.html>



Name:

Date:

C# Lab

Invaders

This lab gives you a spec that describes a program for you to build, using the knowledge you've gained over the last few chapters.

This project is bigger than the ones you've seen so far. So read the whole thing before you get started, and give yourself a little time. And don't worry if you get stuck—there's nothing new in here, so you can move on in the book and come back to the lab later.

We've filled in a few design details for you, and we've made sure you've got all the pieces you need... and nothing else.

It's up to you to finish the job. You can download an executable for this lab from the website... but we won't give you the code for the answer.

The grandfather of video games

In this lab you'll pay homage to one of the most popular, revered and replicated icons in video game history, a game that needs no further introduction. **It's time to build Invaders.**

As the player destroys the invaders, the score goes up. It's displayed in the upper left-hand corner.

The invaders attack in waves of 30. The first wave moves slowly and fires a few shots at a time. The next wave moves faster, and fires more shots more frequently. If all 30 invaders in a wave are destroyed, the next wave attacks.

The player starts out with three ships. The first ship is in play, and the other two are kept in reserve. His spare ships are shown in the upper right-hand corner.



The player moves the ship left and right, and fires shots at the invaders. If a shot hits an invader, the invader is destroyed and the player's score goes up.

The invaders return fire. If one of the shots hits the ship, the player loses a life. Once all lives are gone, or if the invaders reach the bottom of the screen, the game ends and a big "GAME OVER" is displayed in the middle of the screen.

The multicolored stars in the background twinkle on and off, but don't affect gameplay at all.

Your mission: defend the planet against wave after wave of invaders

The invaders attack in waves, where each wave is a tight formation of 30 individual invaders. As the player destroys invaders, the score goes up. The bottom invaders are shaped like stars and worth 10 points. The spaceships are worth 20, the saucers are worth 30, the bugs are worth 40, and the satellites are worth 50. The player starts with three lives. If he loses all three lives or the invaders reach the bottom of the screen, the game's over.

There are five different types of invaders, but they all behave the same way. They start at the top of the screen and move left until they reach the edge. Then they drop down and start moving right. When they reach the right-hand boundary, they drop down and move left again. If the invaders reach the bottom of the screen, the game's over.

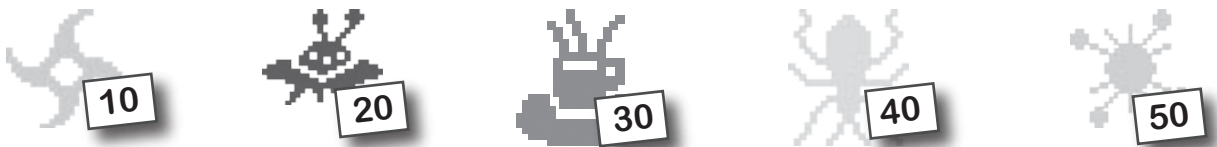

The first wave of invaders can fire two shots at once—the invaders will hold their fire if there are more than two shots on the screen. The next wave fires three, the next fires four, etc.

The spacebar shoots. But there can only be two player shots on the screen at once. As soon as a shot hits something or disappears, another shot can be fired.



If a shot hits an invader, both disappear. Otherwise, the shot disappears when it gets to the top of the screen.

The game should keep track of which keys are currently being held down. So pressing right and spacebar would cause the ship to move to the right and fire (if two shots aren't already on the screen).

The left arrow moves the ship towards the left-hand edge of the screen.



The right arrow key moves the ship to the right.

The architecture of Invaders

Invaders needs to keep track of a wave of 30 invaders (including their locations, type, and score value), the player's ship, shots that the player and invaders fire at each other, and stars in the background. As you did in the Quest lab, you'll need a Game object to keep up with all this, and coordinate between the form and the game objects.

Here's an overview of what you'll need to create:

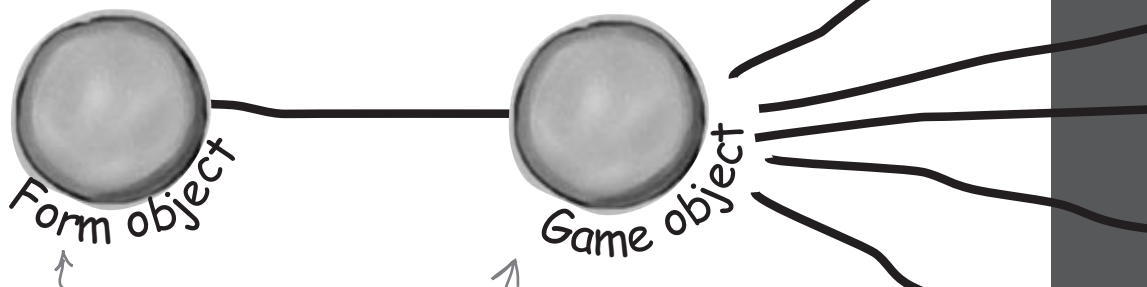

The form is pretty simple. It's got timers to tell the game to go, it passes on key presses, and animates the invaders and twinkling stars. And it's got a Paint event handler to draw the graphics, which just calls the Game object's Draw() method.

The Game object manages the gameplay. It keeps track of how many lives the player has left and how many waves of invaders have attacked. When the game's over, it raises a GameOver event to tell the form to stop its timers.

All of the invaders on the screen are stored in a List. When an invader's destroyed, it's removed from the list so the game stops drawing it.

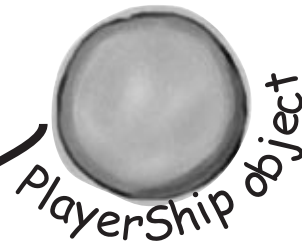

The object that represents the ship keeps track of its position and moves itself left and right, making sure it doesn't move off the side of the screen.



The game keeps two lists of Shot objects: a list of shots the player fired at the invaders, and a list of shots the invaders fired back.

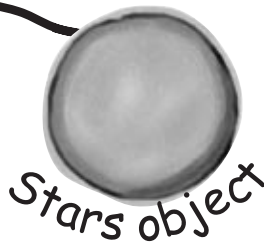

The Stars object keeps a List of Star structs (each of which contain a Point and a Pen). Stars also has a Twinkle() method that removes five stars at random and adds five new ones—the game calls Twinkle() several times a second to make the stars twinkle in the background.

Design the Invaders form

The Invaders form has only two controls: a timer to trigger animation (making the stars twinkle and the invaders animate by changing each invader picture to a different frame), and a timer to handle gameplay (the invaders marching left and right, the player moving, and the player and invaders shooting at each other). Other than that, the only intelligence in the form is an event handler to handle the game's GameOver event, and KeyUp and KeyDown event handlers to manage the keyboard input.

The form fires a KeyDown event any time a key is pressed, and it fires a KeyUp event whenever a key is released.

When the form initializes its Game object, it passes its ClientRectangle to it so it knows the boundaries of the form. So you can change the size of the battlefield just by changing the size of the form.

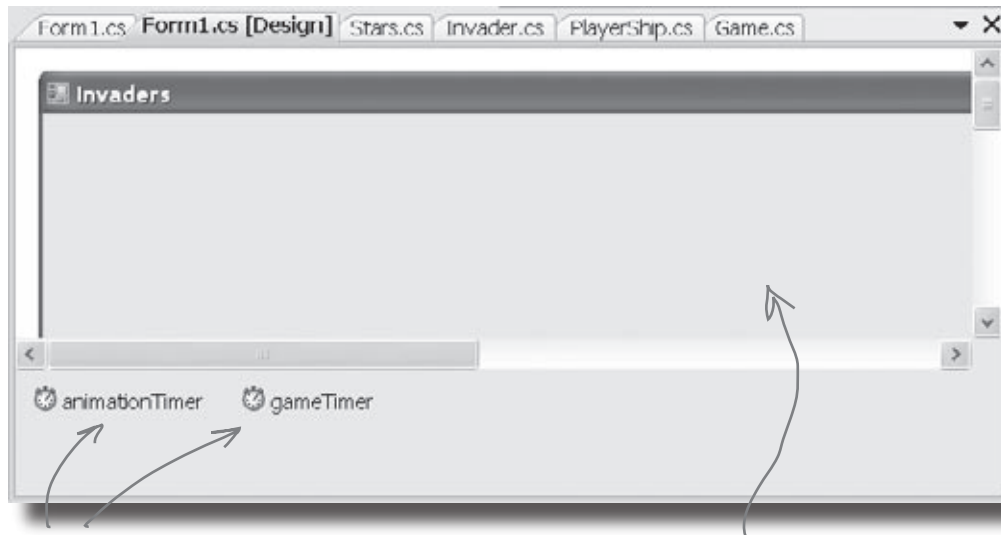

You should add two timers: animationTimer and gameTimer.

Set the form's FormBorderStyle property to FixedSingle, its DoubleBuffered property to true, turn off its MinimizeBox and MaximizeBox properties, set its title, and then stretch it out to the width you want the game area to be.

The animation timer handles the eye candy

The stars in the game's background and the invader animation don't affect gameplay, and they continue when the game is paused or stopped. So we need a separate timer for those.

 animationTimer

Add code for the animation timer's tick event

Your code should have a counter that cycles from 0 to 3 and then back down to 0. That counter is used to update each of the four-cell invader animations (creating a smooth animation). Your handler should also call the Game object's `Twinkle()` method, which will cause the stars to twinkle. Finally, it needs to call the form's `Refresh()` method to repaint the screen.

Try a timer interval of 33ms, which will give you about 30 frames per second. Make sure you set the game timer to a shorter interval, though. The ship should move and gameplay should occur more quickly than the stars twinkle.

← Animation occurs even when gameplay doesn't. That means that the stars twinkle and the invaders animate even if the game is over, paused, or hasn't been started.

Adjust the timers for smooth animation

With a 33ms interval for animation, set the game timer to 10ms. That way, the main gameplay will occur more quickly than the animation (which is really just background eye candy). At the same time, the `Go()` method in Game (fired by the game timer, which we'll talk about in a little bit) can take a lot of CPU cycles. If the CPU is busy handling gameplay, the animation timer will just wait until the CPU gets to it, and then fire (and animate the stars and invaders).

Alternately, you can just set both timers to an interval of 5ms, and the game will run and animate about as fast as your system can handle (although on fast machines, animation could get annoyingly quick).

← If the animation timer is set to 33ms, but the Game object's `Go()` method takes longer than that to run, then animation will occur once `Go()` completes.

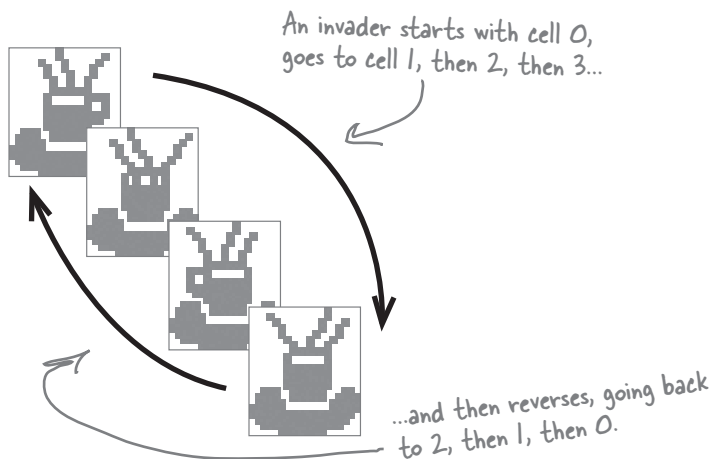

↑ We tried things out on a slow machine, and found that setting the animation interval to 100ms and the gameplay timer interval to 50ms gave us a frame rate of about 10 frames per second, which was definitely playable. Try starting there and reducing each interval until you're happy.

Respond to keyboard input

Before we can code the game timer, we need to write event handlers for the `KeyDown` and `KeyUp` events. `KeyDown` is triggered when a key is pressed, and `KeyUp` when a key is released. For most keys, we can simply take action, by firing a shot or quitting the game.

For some keys, like the right or left arrow, we want to store those in a list that our game timer can then use to move the player's ship. So we'll also need a list of pressed keys in the form object:

```
List<Keys> keysPressed = new List<Keys>();
```

```
private void Form1_KeyDown(object sender, KeyEventArgs e) {
    if (e.KeyCode == Keys.Q)
        Application.Exit();
```

The `Keys` enum defines all the keys you might want to check key codes against.

```
if (gameOver)
    if (e.KeyCode == Keys.S) {
        // code to reset the game and restart the timers
        return;
    }
```

```
if (e.KeyCode == Keys.Space)
    game.FireShot();
if (keysPressed.Contains(e.KeyCode))
    keysPressed.Remove(e.KeyCode);
keysPressed.Add(e.KeyCode);
}
```

The key that's pressed gets added to our key list, which we'll use in a second.

```
private void Form1_KeyUp(object sender, KeyEventArgs e) {
    if (keysPressed.Contains(e.KeyCode))
        keysPressed.Remove(e.KeyCode);
}
```

When a key is released, we remove it from our list of pressed keys.

So if the player's holding down the left arrow and space bar at the same time, the list will contain `Keys.Left` and `Keys.Space`.

We need a list of keys so we can track which keys have been pressed. Our game timer will need that list for movement in just a bit.

The 'Q' key quits the game.

If the game has ended, reset the game and start over.

But we only want this to work if the game's over. Pressing S shouldn't restart a game that's already in progress.

// code to reset the game and restart the timers

You'll need to fill in this code.

The spacebar fires a shot.

By removing the key and then re-adding it, it makes the key the last (most current) item in the list.

We want the most current key pressed to be at the very top of the list, so that if the player mashes a few keys at the same time, the game responds to the one that hit most recently. Then, when he lets up one key, the game responds to the next one in the list.

The game timer handles movement and gameplay

The main job of the form's game timer is to call `Go()` in the `Game` class. But it also has to respond to any keys pressed, so it has to check the `keysPressed` list to find any keys caught by the `KeyDown` and `KeyUp` events:

 gameTimer

Make sure your naming matches up with what you call your handler methods.

```
private void gameTimer_Tick(object sender, EventArgs e) {
    if (keysPressed.Count() >= 1) {
        switch (keysPressed[0]) {
            case Keys.Left:
                game.MovePlayer(Direction.Left);
                break;
            case Keys.Right:
                game.MovePlayer(Direction.Right);
                break;
        }
    }
    game.Go();
}
```

keysPressed is your List<Keys> object managed by the `KeyDown` and `KeyUp` event handlers. The key at index zero will always be the most recent key pressed.

The `KeyUp` and `KeyDown` events use the `Keys` enum to specify a key. We'll use `Keys.Left` and `Keys.Right` to move the ship.

We only need to deal with movement. Other keys, like spacebar, and 'Q' for quit, are handled in the `KeyDown()` method you just wrote.

Finally, we call `Go()` on the `Game` object to let game play continue.

Shots move up and down, the player moves left and right, and the invaders move left, right, and down. You'll need this enum to keep all those directions straight.

```
public enum Direction {
    Left,
    Right,
    Up,
    Down,
}
```

One more form detail: the GameOver event

Add a private `bool` field called `gameOver` to the form that's true only when the game is over. Then add an event handler for the `Game` object's `GameOver` event that stops the game timer (but not the animation timer, so the stars still twinkle and the invaders still animate), sets `gameOver` to true, and calls the form's `Invalidate()` method.

When you write the form's `Paint` event handler, have it check `gameOver`. If it's true, have it write `GAME OVER` in big yellow letters in the middle of the screen. Then have it write "Press S to start a new game or Q to quit" in the lower right-hand corner. You can start the game out in this state, so the user has to hit S to start a new game.

Here's an example of adding another event to a form without using the IDE. This is all manual coding.

The game over event and its delegate live in the `Game` class, which you'll see in just a minute.

The form's game timer tells the game to Go()

In addition to handling movement left and right, the main job of the game timer is to call the Game object's Go () method. That's where all of the gameplay is managed. The Game object keeps track of the state of the game, and its Go () method advances the game by one frame. That involves:

- 1 **Checking to see if the player died**, using its Alive property. When the player dies, the game shows a little animation of the ship collapsing (using DrawImage () to squish the ship down to nothing). The animation is done by the PlayerShip class, so Go () just needs to check to see if it's dead. If it is, it returns—that way, it keeps the invaders from moving or shooting while the player gets a small break (and watches his ship get crushed).
- 2 **Moving each of the shots**. Shots fired by the invaders move down, and shots fired by the player move up. Game keeps two List<Shot> objects, one for the invaders' shots and one for the player's. Any shot that's moved off the screen needs to be removed from the list.
- 3 **Moving each of the invaders**. Game calls each Invader object's Move () method, and tells the invaders which way to move. Game also keeps up with where the invaders are in case they need to move down a row or switch directions. Then, Game checks to see if it's time for the invaders to return fire, and if so, it adds new Shot objects to the List<>.
- 4 **Checking for hits**. If a player's shot hit any invaders, Game removes the invaders from the appropriate List<>. Then Game checks to see if any of the invader shots have collided with the player's ship, and if so, it kills the player by setting its Alive property to false. If the player's out of lives, then Game raises the GameOver event to tell the form that the game's over. The form's GameOver event handler stops its game timer, so Go () isn't called again.

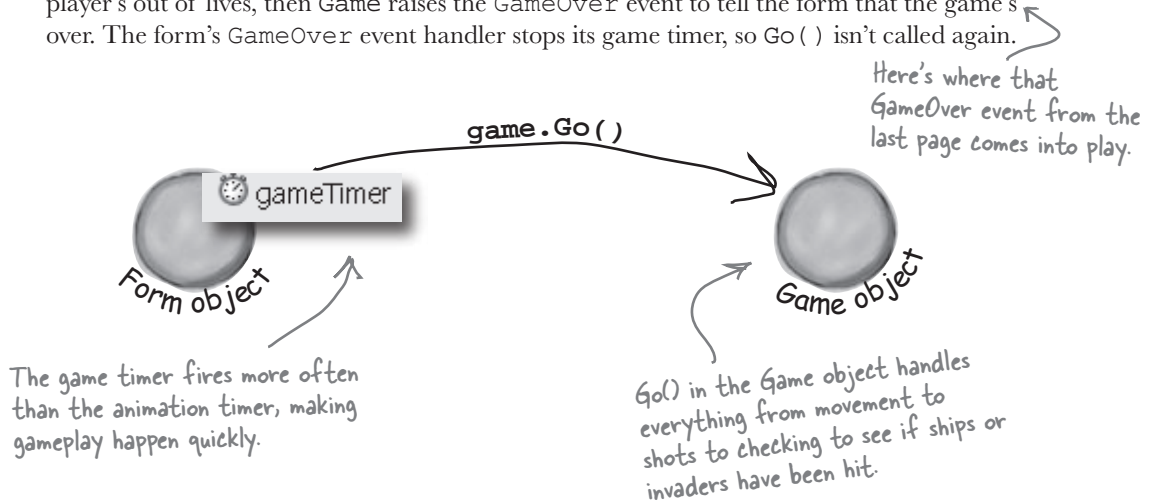

Taking control of graphics

In earlier labs, the form used controls for the graphics. But now that you know how to use `Graphics` and double-buffering, the `Game` object should handle a lot of the drawing.

So the form should have a `Paint` event handler (make sure you set the form's `DoubleBuffered` property to `true`!). You'll delegate the rest of the drawing to the `Game` object by calling its `Draw()` method every time the form's `Paint` event fires.

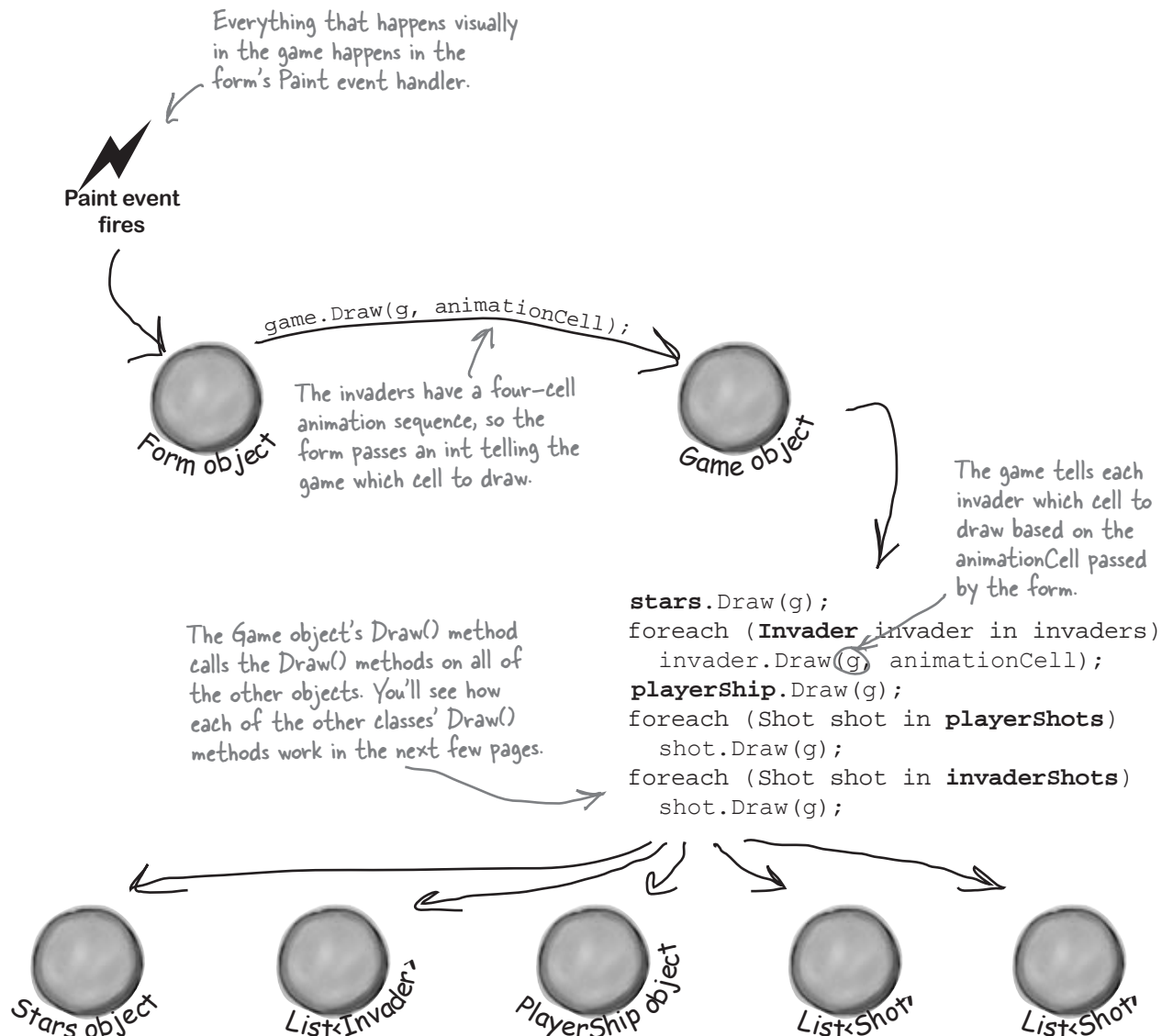

Building the Game class

The Game class is the controller for the Invaders game. Here's a start on what this class should look like, although there's lots of work still for you to do.

```
public class Game {
    private int score = 0;
    private int livesLeft = 2;
    private int wave = 0;
    private int framesSkipped = 0;

    private Rectangle boundaries;
    private Random random;

    private Direction invaderDirection;
    private List<Invader> invaders;

    private PlayerShip playerShip;
    private List<Shot> playerShots;
    private List<Shot> invaderShots;

    private Stars stars;

    public event EventHandler GameOver;

    // etc...
}
```

The score, livesLeft, and wave fields keep track of some basic information about the state of the game.

You'll use the frame field to slow down the invaders early on in the game—the first wave should skip 6 frames before they move to the left, the next wave should skip 5, the next should skip 4, etc.

This List<> of Invader objects keeps track of all of the invaders in the current wave. When an invader is destroyed, it's removed from the list. The game checks periodically to make sure the list isn't empty—if it is, it sends in the next wave of invaders.

This Stars object keeps track of the multicolored stars in the background.

The Game object raises its GameOver event when the player dies and doesn't have any more lives left. You'll build the event handler method in the form, and hook it into the Game object's GameOver event.

Most of these methods combine methods on other objects to make a specific action occur.

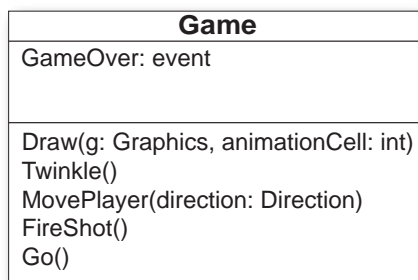

Remember, these are the public methods. You may need a lot more private methods to structure your code in a way that makes sense to you.

The Game class methods

The Game class has five public methods that get triggered by different events happening in the form.

1 The Draw() method draws the game on a graphics object

The `Draw()` method takes two parameters: a `Graphics` object and an integer that contains the animation cell (a number from 0 to 3). First, it should draw a black rectangle that fills up the whole form (using the display rectangle stored in `boundaries`, received from the form). Then the method should draw the stars, the invaders, then the player's ship, and then the shots. Finally, it should draw the score in the upper left-hand corner, the player's ships in the upper right-hand corner, and a big "GAME OVER" in yellow letters if `gameOver` is `true`.

2 The Twinkle() method twinkles the stars

The form's animation timer event handler needs to be able to twinkle the stars, so the Game object needs a one-line method to call `stars.Twinkle()`.

We'll write code for the Stars object in a few more pages.

3 The MovePlayer() method moves the player

The form's keyboard timer event handler needs to move the player's ship, so the Game object also needs a two-line method that takes a `Direction` enum as a parameter, checks whether or not the player's dead, and calls `playerShip.Move()` to affect that movement.

4 The FireShot() method makes the player fire a shot at the invaders

The `FireShot()` method checks to see if there are fewer than two player shots on screen. If there are, the method should add a new shot to the `playerShots` list at the right location.

5 The Go() method makes the game go

The form's animation timer calls the Game object's `Go()` method anywhere between 10 and 30 times a second (depending on the computer's CPU speed). The `Go()` method does everything the game needs to do to advance itself by a frame:

- ★ The game checks if the player's dead using its **Alive** property. If he's still alive, the game isn't over yet—if it were, the form would have stopped the animation timer with its `Stop()` method. So the `Go()` method won't do anything else until the ship's alive again—it'll just return.
- ★ Every shot needs to be updated. The game needs to loop through both `List<Shot>` objects, calling each shot's `Move()` method. If any shot's `Move()` returns false, that means the shot went off the edge of the screen—so it gets deleted from the list.
- ★ The game then moves each invader, and allows them to return fire.
- ★ Finally, it checks for collisions: first for any shot that overlaps an invader (and removing both from their `List<>`s), and then to see if the player's been shot. We'll add a `Rectangle` property called `Area` to the `Invader` and `PlayerShip` classes—so we can use the `Contains()` method to see if the ships' area overlaps with a shot.

Filling out the Game class

The problem with class diagrams is that they usually leave out any non-public properties and methods. So even after you've got the methods from page 693 done, you've still got a lot of work to do. Here are some things to think about:

The constructor sets everything up

The Game object needs to create all of the other objects—the Invader objects, the PlayerShip object, the List objects to hold the shots, and the Stars object. The form passes in an initialized Random object and its own ClientRectangle struct (so the Game can **figure out the boundaries of the battlefield**, which it uses to determine when shots are out of range and when the invaders reached the edge and need to drop and reverse direction). Then, your code should create everything else in the game world.

We'll talk about most of these individual objects over the next several pages of this lab.

Build a NextWave() method

A simple method to create the next wave of invaders will come in handy. It should assign a new List of Invader objects to the invaders field, add the 30 invaders in 6 columns so that they're in their starting positions, increase the wave field by 1, and set the invaderDirection field to start them moving towards the right-hand side of the screen. You'll also change the framesSkipped field.

Here's an example of a private method that will really help out your Game class organization.

A few other ideas for private methods

Here are a few of the private method ideas you might play with, and see if these would also help the design of your Game class:

- ✓ A method to see if the player's been hit (CheckForPlayerCollisions ())
- ✓ A method to see if any invaders have been hit (CheckForInvaderCollisions ())
- ✓ A method to move all the invaders (MoveInvaders ())
- ✓ A method allowing invaders to return fire (ReturnFire ())



It's possible to show protected and private properties and methods on a class diagram, but you'll rarely see that put into practice. Why do you think that is?

LINQ makes collision detection much easier

You've got collections of invaders and shots, and you need to search through those collections to find certain invaders and shots. Anytime you hear collections and searching in the same sentence, you should think LINQ. Here's what you need to do:

This seems really complex when you first read it, but each LINQ query is just a couple of lines of code. Here's a hint: don't overcomplicate it!

1 Figure out if the invaders' formation has reached the edge of the battlefield

The invaders need to change direction if any one invader is within 100 pixels of the edge of the battlefield. When the invaders are marching to the right, once they reach the right-hand side of the form the game needs to tell them to drop down and start marching to the left. And when the invaders are marching to the left, the game needs to check if they've reached the left edge. To make this happen, add a private `MoveInvaders()` method that gets called by `Go()`. The first thing it should do is check and update the private `framesSkipped` field, and `return` if this frame should be skipped (depending on the level). Then it should check which direction the invaders are moving. If the invaders are moving to the right, `MoveInvaders()` should use LINQ to search the `invaderCollection` list for any invader whose location's X value is within 100 pixels of the right-hand boundary. If it finds any, then it should tell the invaders to march downwards and then set `invaderDirection` equal to `Direction.Left`; if not, it can tell each invader to march to the right. On the other hand, if the invaders are moving to the left, then it should do the opposite, using another LINQ query to see if the invaders are within 100 pixels of the left-hand boundary, marching them down and changing direction if they are.

2 Determine which invaders can return fire

Add a private method called `ReturnFire()` that gets called by `Go()`. First, it should `return` if the invaders' shot list already has `wave + 1` shots. It should also `return` if `random.Next(10) < 10 - wave`. (That makes the invaders fire at random, and not all the time.) If it gets past both tests, it can use LINQ to group the invaders by their `Location.X` and sort them `descending`. Once it's got those groups, it can choose a group at random, and use its `First()` method to find the invader at the bottom of the column. All right, now you've got the shooter—you can add a shot to the invader's shot list just below the middle of the invader (use the invader's `Area` to set the shot's location).

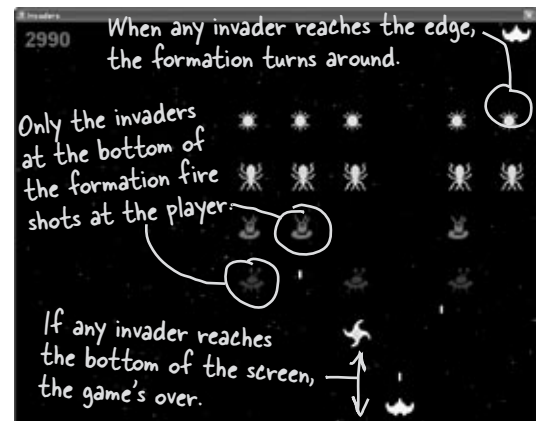

3 Check for invader and player collisions

You'll want to create a method to check for collisions. There are three collisions to check for, and the `Rectangle` struct's `Contains()` method will come in really handy—just pass it any `Point`, and it'll `return true` if that point is inside the rectangle.

- ★ Use LINQ to find any dead invaders by looping through the shots in the player's shot list and selecting any invader where `invader.Area` contains the shot's location. Remove the invader and the shot.
- ★ Add a query to figure out if any invaders reached the bottom of the screen—if so, end the game.
- ★ You don't need LINQ to look for shots that collided with the player, just a loop and the player's `Area` property. (Remember, **you can't modify a collection inside a foreach loop**. If you do, you'll get an `InvalidOperationException` with a message that the collection was modified.)

Crafting the Invader class

The `Invader` class keeps track of a single invader. So when the `Game` object creates a new wave of invaders, it adds 30 instances of `Invader` to a `List<Invader>` object. Every time its `Go()` method is called, it calls each invader's `Move()` method to tell it to move. And every time its `Draw()` method is called, it calls each invader object's `Draw()` method. So you'll need to build out the `Move()` and `Draw()` methods. And you'll want to add a private method called `InvaderImage()` too—it'll come in really handy when you're drawing the invader. Make sure you call it inside the `Draw()` method to keep the `image` field up to date:

```
public class Invader {
    private const int HorizontalInterval = 10;
    private const int VerticalInterval = 40;
    public enum Type {
        Bug,
        Saucer,
        Satellite,
        Spaceship,
        Star,
    }

    private Bitmap image;

    public Point Location { get; private set; }

    public Type InvaderType { get; private set; }

    public Rectangle Area { get {
        return new Rectangle(location, image.Size); }
    }

    public int Score { get; private set; }

    public Invader(Type invaderType, Point location, int score) {
        this.InvaderType = invaderType;
        this.Location = location;
        this.Score = score;
        image = InvaderImage(0);
    }

    // Additional methods will go here
}
```

The invader uses the `Type` enum to figure out what kind of enemy ship it is.

The `HorizontalInterval` constant determines how many pixels an invader moves every time it marches left or right. `VerticalInterval` is the number of pixels it drops down when the formation reaches the edge of the battlefield.

Check out what we did with the `Area` property. Since we know the invader's location and we know its size (from its `image` field), we can add a get accessor that calculates a `Rectangle` for the area it covers... which means you can use the `Rectangle`'s `Contains()` method inside a `LINQ` query to detect any shots that collided with an invader.

Invader
Location: Point
InvaderType: Type
Area: Rectangle
Score: int
Draw(g: Graphics, animationCell: int)
Move(direction: Direction)

Build the Invaders' methods

The three core methods for `Invader` are `Move()`, `Draw()`, and `InvaderImage()`. Let's look at each in turn:

Move the invader ships

First, you need a method to move the invader ships. The `Game` object should send in a direction, using the `Direction` enum, and then the ship should move. Remember, the `Game` object handles figuring out if an invader needs to move down or change direction, so your `Invader` class doesn't have to worry about that.

```
public void Move(Direction direction) {
    // This method needs to move the ship in the
    //   specified direction
}
```

Draw the ship - and the right animation cell

Each `Invader` knows how to draw itself. Given a `Graphics` object to draw to, and the animation cell to use, the invader can display itself onto the game board using the `Graphics` object the `Game` gives it.

```
public void Draw(Graphics g, int animationCell) {
    // This method needs to draw the image of
    //   the ship, using the correct animation cell
}
```

Get the right Invader image

You're going to need to grab the right image based on the animation cell a lot, so you may want to pull that code into its own method. Build an `InvaderImage()` method that returns a specific `Bitmap` given an animation cell.

```
private Bitmap InvaderImage(int animationCell) {
    // This is mostly a convenience method, and
    //   returns the right bitmap for the specified cell
}
```

There are five types of invaders, and each of them has four different animation cell pictures.



Each invader knows its type. So if you give its `InvaderImage()` method a number for its animation cell, it can return a `Bitmap` that's got the right graphic in it.

The player's ship can move and die

The `PlayerShip` class keeps track of the player's ship. It's similar to the `Invaders` class, but even simpler.

The `Location` and `Area` properties are exactly like the ones in the `Invader` class.

The `Draw()` method just draws the player's ship in the right location—unless the player died, in which case it draws an animation of the ship getting crushed by the shot.

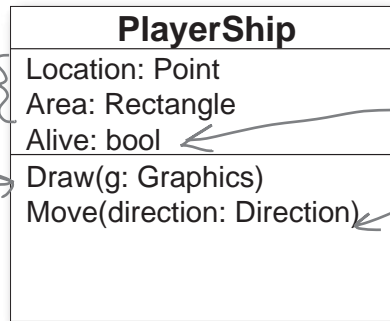

When the ship's hit with a shot, the game sets the ship's `Alive` property to false. The game then keeps the invaders from moving until the ship resets its `Alive` property back to true.

The `Move()` method takes one parameter, a `Direction` enum, and moves the player in that direction.

Animate the player ship when it's hit

The `Draw()` method should take a `Graphics` object as a parameter. Then it checks its `Alive` property. If it's alive, it draws itself using its `Location` property. If it's dead, then instead of drawing the regular bitmap on the graphics, the `PlayerShip` object uses its private `deadShipHeight` field to animate the player ship slowly getting crushed by the shot. After three seconds of being dead, it should flip its `Alive` property back to true.

`PlayerShip` needs to take in a `Rectangle` with the game's boundaries in its constructor, and make sure the ship doesn't get moved out of the game's boundaries in `Move()`.

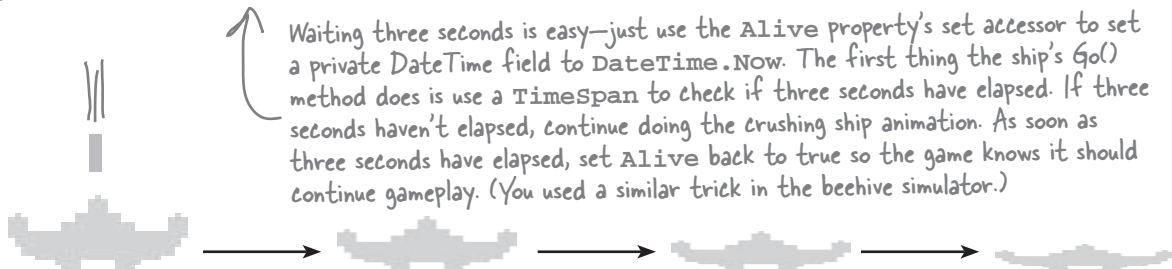

Waiting three seconds is easy—just use the `Alive` property's set accessor to set a private `DateTime` field to `DateTime.Now`. The first thing the ship's `Go()` method does is use a `TimeSpan` to check if three seconds have elapsed. If three seconds haven't elapsed, continue doing the crushing ship animation. As soon as three seconds have elapsed, set `Alive` back to true so the game knows it should continue gameplay. (You used a similar trick in the beehive simulator.)

```
public void Draw(Graphics g) {
    if (!Alive) {
        Reset the deadShipHeight field and draw the ship.
    } else {
        Check the deadShipHeight field. If it's greater than zero, decrease it by 1 and use DrawImage() to draw the ship a little flatter.
    }
}
```

“Shots fired!”

Game has two lists of `Shot` objects: one for the player’s shots, moving up the screen, and one for enemy shots, moving down the screen.

`Shot` only needs a few things to work: a `Point` location, a method to draw the shot, and a method to move. Here’s the class diagram:

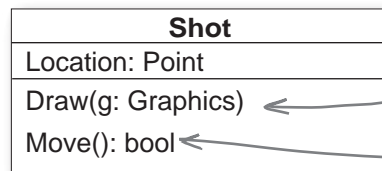

`Draw()` handles drawing the little rectangle for this shot. Game will call this every time the screen needs to be updated.

`Move()` moves the shot up or down, and keeps up with whether the shot is within the game’s boundaries.

Here’s a start on the `Shot` class:

```
public class Shot {
    private const int moveInterval = 20;
    private const int width = 5;
    private const int height = 15;
```

You can adjust these to make the game easier or harder... smaller shots are easier to dodge, faster shots are harder to avoid.

```
    public Point Location { get; private set; }
    private Direction direction;
    private Rectangle boundaries;
```

The shot updates its own location in the `Move()` method, so location can be a read-only automatic property.

```
    public Shot(Point location, Direction direction,
                Rectangle boundaries) {
        this.Location = location;
        this.direction = direction;
        this.boundaries = boundaries;
    }
```

`Direction` is the enum with `Up` and `Down` defined.

The game passes the form’s display rectangle into the constructor’s `boundaries` parameter so the shot can tell when it’s off of the screen.

```
    // Your code goes here
}
```

Your job is to make sure `Draw()` takes in a `Graphics` object and draws the shot as a yellow rectangle. Then, `Move()` should move the shot up or down, and return true if the shot is still within the game boundaries.

Twinkle, twinkle... it's up to you

The last class you'll need is the Stars class. There are 300 stars, and this class keeps up with all of them, causing 5 to display and 5 to disappear every time `Twinkle()` is called.

First, though, you'll need a `struct` for each star:

```
private struct Star {
    public Point point;
    public Pen pen;
}

public Star(Point point, Pen pen) {
    this.point = point;
    this.pen = pen;
}
```

Each star has a point (its location) and a pen (for its color).

All Star does is hold this data... no behavior.

The Stars class should keep a `List<Star>` for storing 300 of these Star structs. You'll need to build a constructor for Stars that populates that list. The constructor will get a `Rectangle` with the display boundaries, and a `Random` instance for use in creating the random Points to place each star in a random location.

Here's the class diagram for Stars, with the other methods you'll need:

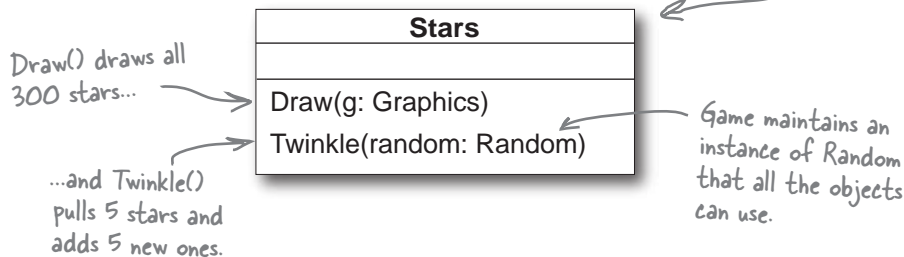

`Draw()` should draw all the stars in the list, and `Twinkle()` should remove five random stars and add five new stars in their place.

You might also want to create a `RandomPen()` method so you can get a random color for the stars every time you create a new star easily. It should return one of the five colors stars come in, by generating a number between 0 and 4, and selecting the matching `Pen` object.

Here's another hint: start out the project with just a form, a `Game` class and `Stars` class. See if you can get it to draw a black sky with twinkling stars. That'll give you a solid foundation to add the other classes and methods.

You can define the Star struct inside Stars.cs, as only Stars needs to use that struct.



And yet there's more to do...

Think the game's looking pretty good? You can take it to the next level with a few more additions:

Add animated explosions

Make each invader explode after it's hit, then briefly display a number to tell the player how many points the invader was worth.

Add a mothership

Once in a while, a mothership worth 250 points can travel across the top of the battlefield. If the player hits it, they get a bonus.

Add shields

Add floating shields the player can hide behind. You can add simple shields the enemies and player can't shoot through. Then, if you really want your game to shine, add breakable shields that the player and invaders can blast holes through after a certain number of hits.

← Try making the shields last for fewer hits at higher levels of the game.

Add divebombers

Create a special type of enemy that divebombs the player. A divebombing enemy should break formation, take off towards the enemy, fly down around the bottom of the screen, and then resume its position.

Add more weapons

Start an arms race! Smart bombs, lasers, guided missiles... there are all sorts of weapons that both the player and the invaders can use to attack each other. See if you can add three new weapons to the game.

Add more graphics

You can go to www.headfirstlabs.com/books/hfcsharp/ to find more graphics files for simple shields, a mothership, and more. We provided blocky, pixelated graphics to give it that stylized '80s look. Can you come up with your own graphics to give the game a new style?

A good class design should let you change out graphics with minimal code changes.

This is your chance to show off! Did you come up with a cool new version of the game? Join the Head First C# forum and claim your bragging rights: www.headfirstlabs.com/books/hfcsharp/

appendix i: leftovers *

The top 5 things we wanted to include in this book

I'm still hungry for more!



The fun's just beginning!

We've shown you a lot of great tools to build some really **powerful software** with C#. But there's no way that we could include **every single tool, technology, or technique** in this book—there just aren't enough pages. We had to make some *really tough choices* about what to include and what to leave out. Here are some of the topics that didn't make the cut. But even though we couldn't get to them, we still think that they're **important and useful**, and we wanted to give you a small head start with them.

#1 LINQ to XML

XML—or **Extensible Markup Language**—is a format for files and data streams that represents complex data as text. The .NET framework gives you some really powerful tools for creating, loading and saving XML files. And once you've got your hands on XML data, you can use LINQ to query it. Add “using System.Xml.Linq;” to the top of a file and enter this method—it generates an XML document to store Starbuzz customer loyalty data.

```
private static XDocument GetStarbuzzData() {
    XDocument doc = new XDocument(
        new XDeclaration("1.0", "utf-8", "yes"),
        new XComment("Starbuzz Customer Loyalty Data"),
        new XElement("starbuzzData",
            new XAttribute("storeName", "Park Slope"),
            new XAttribute("location", "Brooklyn, NY"),
            new XElement("person",
                new XElement("personalInfo",
                    new XElement("name", "Janet Venutian"),
                    new XElement("zip", 11215)),
                new XElement("favoriteDrink", "Choco Macchiato"),
                new XElement("moneySpent", 255),
                new XElement("visits", 50)),
            new XElement("person",
                new XElement("personalInfo",
                    new XElement("name", "Liz Nelson"),
                    new XElement("zip", 11238)),
                new XElement("favoriteDrink", "Double Cappuccino"),
                new XElement("moneySpent", 150),
                new XElement("visits", 35)),
            new XElement("person",
                new XElement("personalInfo",
                    new XElement("name", "Matt Franks"),
                    new XElement("zip", 11217)),
                new XElement("favoriteDrink", "Zesty Lemon Chai"),
                new XElement("moneySpent", 75),
                new XElement("visits", 15)),
            new XElement("person",
                new XElement("personalInfo",
                    new XElement("name", "Joe Ng"),
                    new XElement("zip", 11217)),
                new XElement("favoriteDrink", "Banana Split in a Cup"),
                new XElement("moneySpent", 60),
                new XElement("visits", 10)),
            new XElement("person",
                new XElement("personalInfo",
                    new XElement("name", "Sarah Kalter"),
                    new XElement("zip", 11215)),
                new XElement("favoriteDrink", "Boring Coffee"),
                new XElement("moneySpent", 110),
                new XElement("visits", 15)))));
    return doc;
}
```

Save and load XML files

You can write an XDocument object to the console or save it to a file, and you can load an XML file into it:

```
XDocument doc = GetStarbuzzData();
Console.WriteLine(doc.ToString());
doc.Save("starbuzzData.xml");
XDocument anotherDoc = XDocument.Load("starbuzzData.xml");
```

The XDocument object's Load() and Save() methods read and write XML files. And its ToString() method renders everything inside it as one big XML document.

Query your data

Here's a simple LINQ query that queries the Starbuzz data using its XDocument:

```
var data = from item in doc.Descendants("person")
           select new { drink = item.Element("favoriteDrink").Value,
                      moneySpent = item.Element("moneySpent").Value,
                      zipCode = item.Element("personalInfo").Element("zip").Value };
foreach (var p in data)
    Console.WriteLine(p.ToString());
```

The Descendants() method returns a reference to an object that you can plug right into LINQ.

You already know that LINQ lets you call methods and use them as part of the query, and that works really well with the Element() method.

And you can do more complex queries too:

```
var zipcodeGroups = from item in doc.Descendants("person")
                    group item.Element("favoriteDrink").Value
                    by item.Element("personalInfo").Element("zip").Value
                    into zipcodeGroup
                    select zipcodeGroup;
foreach (var group in zipcodeGroups)
    Console.WriteLine("{0} favorite drinks in {1}",
                    group.Distinct().Count(), group.Key);
```

Element() returns an XElement object, and you can use its properties to check specific values in your XML document.

Read data from an RSS feed

You can do some pretty powerful things with LINQ to XML. Here's a simple query to **read articles from our blog**:

```
XDocument ourBlog = XDocument.Load("http://www.stellman-greene.com/feed");
Console.WriteLine(ourBlog.Element("rss").Element("channel").Element("title").Value);
var posts = from post in ourBlog.Descendants("item")
            select new { Title = post.Element("title").Value,
                        Date = post.Element("pubDate").Value };
foreach (var post in posts)
    Console.WriteLine(post.ToString());
```

The XDocument.Load() method has several overloaded constructors. This one pulls XML data from a URL.

Stick a button on a form, make sure you've got "using System.Xml.Linq;" at the top, type this query into its event handler, and check out what it prints to the console.

We used the URL of our blog, Building Better Software.
<http://www.stellman-greene.com/>

#2 Refactoring

Refactoring means changing the way your code is structured without changing its behavior. Whenever you write a complex method, you should take a few minutes to step back and figure out how you can change it so that you make it easier to understand. Luckily, the IDE has some very useful refactoring tools built in. There are all sorts of refactorings you can do—here are some we use often.

Extract a method

When we were writing the control-based renderer for Chapter 13, we originally included this foreach loop:

```

foreach (Bee bee in world.Bees) {
    beeControl = GetBeeControl(bee);
    if (bee.InsideHive) {
        if (fieldForm.Controls.Contains(beeControl)) {
            fieldForm.Controls.Remove(beeControl);
            beeControl.Size = new Size(40, 40);
            hiveForm.Controls.Add(beeControl);
            beeControl.BringToFront();
        } else if (hiveForm.Controls.Contains(beeControl)) {
            hiveForm.Controls.Remove(beeControl);
            beeControl.Size = new Size(20, 20);
            fieldForm.Controls.Add(beeControl);
            beeControl.BringToFront();
        }
    }
    beeControl.Location = bee.Location;
}

```

These four lines move a BeeControl from the Field form to the Hive form.

And these four lines move a BeeControl from the Hive form to the Field form.

One of our tech reviewers, Joe Albahari, pointed out that this was a little hard to read. He suggested that we **extract those two four-line blocks into methods**. So we selected the first block, right-clicked on it, and selected “Refactor >> Extract Method...”—this window popped up:



Then we did the same thing for the other four-line block, extracting it into a method that we named `MoveBeeFromHiveToField()`. Here’s how that foreach loop ended up—it’s a lot easier to read:

```

foreach (Bee bee in world.Bees) {
    beeControl = GetBeeControl(bee);
    if (bee.InsideHive) {
        if (fieldForm.Controls.Contains(beeControl))
            MoveBeeFromFieldToHive(beeControl);
        } else if (hiveForm.Controls.Contains(beeControl))
            MoveBeeFromHiveToField(beeControl, bee);
    }
    beeControl.Location = bee.Location;
}

```

Rename a variable

Back in Chapter 3, we explained how choosing intuitive names for your classes, methods, fields, and variables makes your code a lot easier to understand. The IDE can really help you out when it comes to naming things in your code. Just right-click on any class, variable, field, property, namespace, constant—pretty much anything that you can name—and choose “Refactor >> Rename”. We did it with “beeControl” in the code from the simulator. Here’s what popped up:

This window lets you choose a new name for the item. If we renamed this, say, “Bobbo”, then the IDE would go through the code and change every single occurrence of it to “Bobbo”.

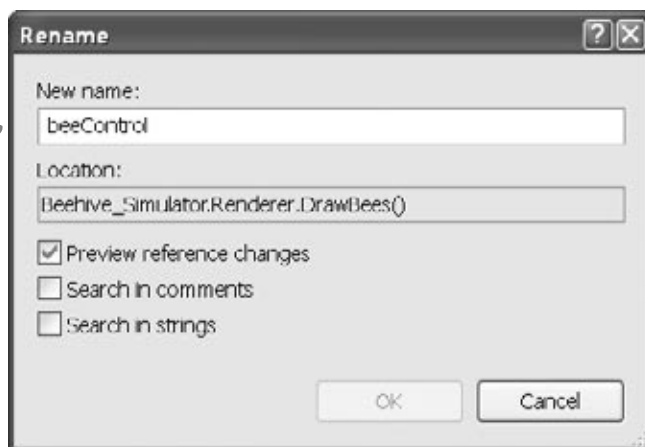

The IDE does a really thorough job of renaming. If you rename a class, it’ll change every statement that instantiates it or uses it. You can click on any occurrence of the name, anywhere in the code, and the IDE will make the change everywhere in your program.

Consolidate a conditional expression

Here’s a neat way to use the “Extract Method” feature. Open up any program, add a button, and add this code to its event handler:

```
private void button1_Click(object sender, EventArgs e) {
    int value = 5;
    string text = "Hi there";
    if (value == 36 || text.Contains("there"))
        MessageBox.Show("Pow!");
}
```

Plus, it’ll even figure out that it should create a static method, since it doesn’t use any fields.

Select everything inside the if statement: `value == 36 || text.Contains("there")`. Then right-click on it and select “Refactor >> Extract Method...”. Here’s what pops up:

Every conditional expression evaluates to a bool, so the IDE will create a method that returns a bool and replace the conditional test with a call to that method.



The expression uses two variables called value and text, so the IDE added parameters to the method using those names.

Not only will this make the code easier to read, but now you’ve got a new method that you can reuse elsewhere!

#3 Some of our favorite Toolbox components

This was a book about learning C#, not learning the ins and outs of the components that ship with .NET. Still, we've got our favorites, and we thought we'd share a few of them with you.

BackgroundWorker is one of those non-visual components (like Timer) that you can drag onto your form that does something really neat—it lets you easily build multithreaded applications.

Just drag one on your form and double-click on it (or, if you want, instantiate it—but don't forget to dispose it!). Then add an event handler to do the work that you want to run in the background.



When you call its `RunWorkerAsync()` method, it fires off the `DoWork()` method—but the catch is that it runs it in **another thread**. That means it does its work in parallel with the other stuff your program's doing.

Your process can report its progress back to you by calling the `BackgroundWorker`'s `ReportProgress()` method—that causes it to raise its `ProgressChanged` event.

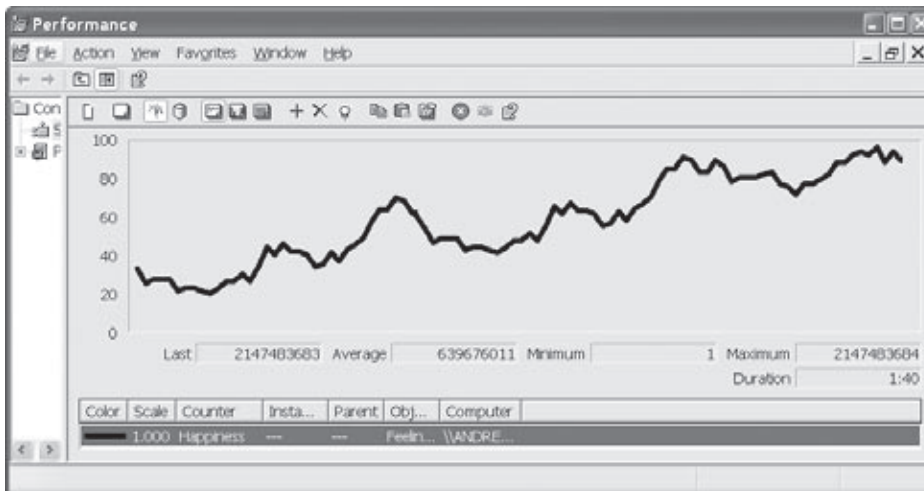

We set up this "Happiness" counter in the "Feelings" category, and fed it data using `PerformanceCounter`.

FileSystemWatcher pretty much does what it sounds like it does—it watches your filesystem to see if something's changed.

You set its Filter property to the type of file it should look for (like *.txt), set the Path property to the directory it needs to watch, and you can tell it to look in subdirectories with its IncludeSubdirectories property.

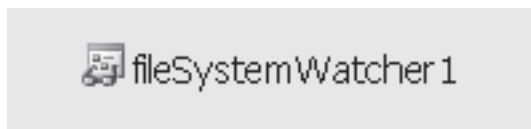

Once you've set it up, it watches the directory for any new or changed files. As soon as a file's added, changed, or deleted, it raises its Changed event. It's also got Created, Deleted, and Renamed events to do more specific tracking.

When the FileSystemWatcher raises an event, it passes information about the file that was changed (or added, or deleted, etc.) using a FileSystemEventArgs object.

When you're writing a program that runs continuously, it's really useful to monitor it. And Windows ships with a nifty tool called Performance Monitor (perfmon.exe) that lets you monitor processes.

The PerformanceCounter component lets you make information about your program available to the Windows performance monitoring system. Use Increment() and Decrement() or set its RawValue property. As soon as you do, you can see the data in the Performance Monitor.

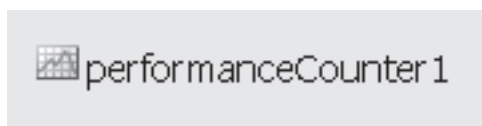

Windows keeps its performance counters in categories, so you'll need to create a category—there are methods in System.Diagnostics that let you do that. Then just hook up your PerformanceCounter to the category you created, and start sending diagnostic info to your heart's delight!

#4 Console Applications

Most C# books start with console applications. We thought that was boring. It's a lot more satisfying to build programs that look like, well...that look like anything at all. And that's what a console program isn't. But sometimes you do need to write a command-line application. Luckily, it's pretty straightforward. Here's how:

1 Create a Console Application project

Any project can be a console application. Go to a project, select “Properties” from the Project menu, and change the “Output type” to “Console Application”. But it's easier to create one from scratch.

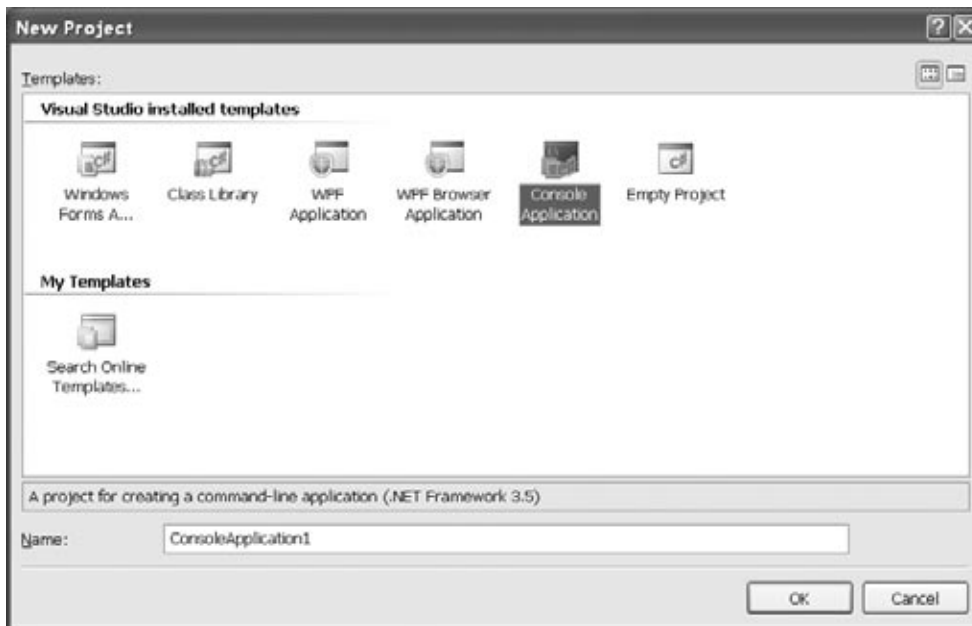

2 The IDE only adds one file—Program.cs

And it's got an empty entry point... and that's it.

```
class Program
{
    static void Main(string[] args)
    {
    }
}
```

Here's a little project for you: Take the hex dumper you built in Chapter 9 and turn it into a console application. Have it read a filename that you pass it on the command-line and print it out as a hex dump. Have it take data from standard input (using the Console.ReadLine()) and dump that data out as a hex dump. Then look up the Unix command "od" and see if you can reproduce it in C#.

3 Use the args parameter for command-line arguments

Your entry point takes one parameter, a string array called `args` that contains the command-line arguments. You already know how to use the `Console.WriteLine()` method—there are some other useful console methods, including `ReadLine()` and `ReadKey()`.

```
class Program {
    static void Main(string[] args) {
        Console.WriteLine("I got {0} arguments", args.Length);
        for (int i = 1; i <= args.Length; i++)
            Console.WriteLine("Argument #{0} is {1}", i, args[i - 1]);
        Console.Write("Enter some text: ");
        string input = Console.ReadLine();
        Console.WriteLine("You entered: {0}", input);
        Console.WriteLine("Press any key to end...");
        Console.ReadKey();
    }
}
```

4 Debug your program in a console window

When you debug your program, the IDE pops up a console window. The `ReadLine()` and `ReadKey()` methods get their input from that window—just type into it. And instead of writing to the Output window, a console application writes to this console window instead. You can set the command-line arguments in the “Debug” page of the Project Properties window.

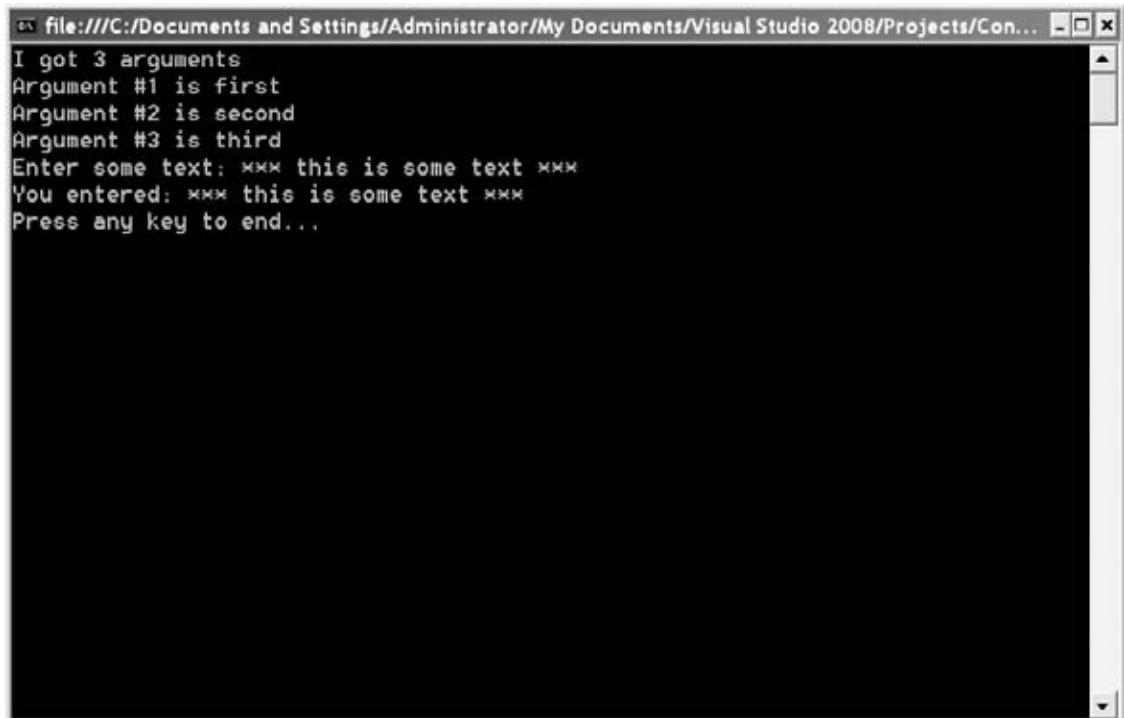

```
file:///C:/Documents and Settings/Administrator/My Documents/Visual Studio 2008/Projects/Con...
I got 3 arguments
Argument #1 is first
Argument #2 is second
Argument #3 is third
Enter some text: *** this is some text ***
You entered: *** this is some text ***
Press any key to end...
```

xaml is pronounced "zammel"

#5 Windows Presentation Foundation

Windows Presentation Framework, or WPF, is Microsoft's next-generation platform for building visual applications. It's pretty amazing—it has XML-based layout, scalable controls, a totally new system for controls, 2-D and 3-D graphics and animation, text flow and document formatting, and there's even a cross-platform web browser plugin that uses it.

Unfortunately, while WPF is a really cool and highly capable technology, it's not a particularly good tool for teaching C#. And that was our goal—getting C# concepts into your brain as quickly and easily as possible.

Take a second and create a new WPF application. Just create a new project using the IDE, but don't create a new Windows Forms Application project. Instead, **select WPF Application**. You'll immediately notice a difference in the IDE:

The biggest difference you'll notice is that the form designer looks nothing like the one you're used to. We'll take a closer look at it in a minute.

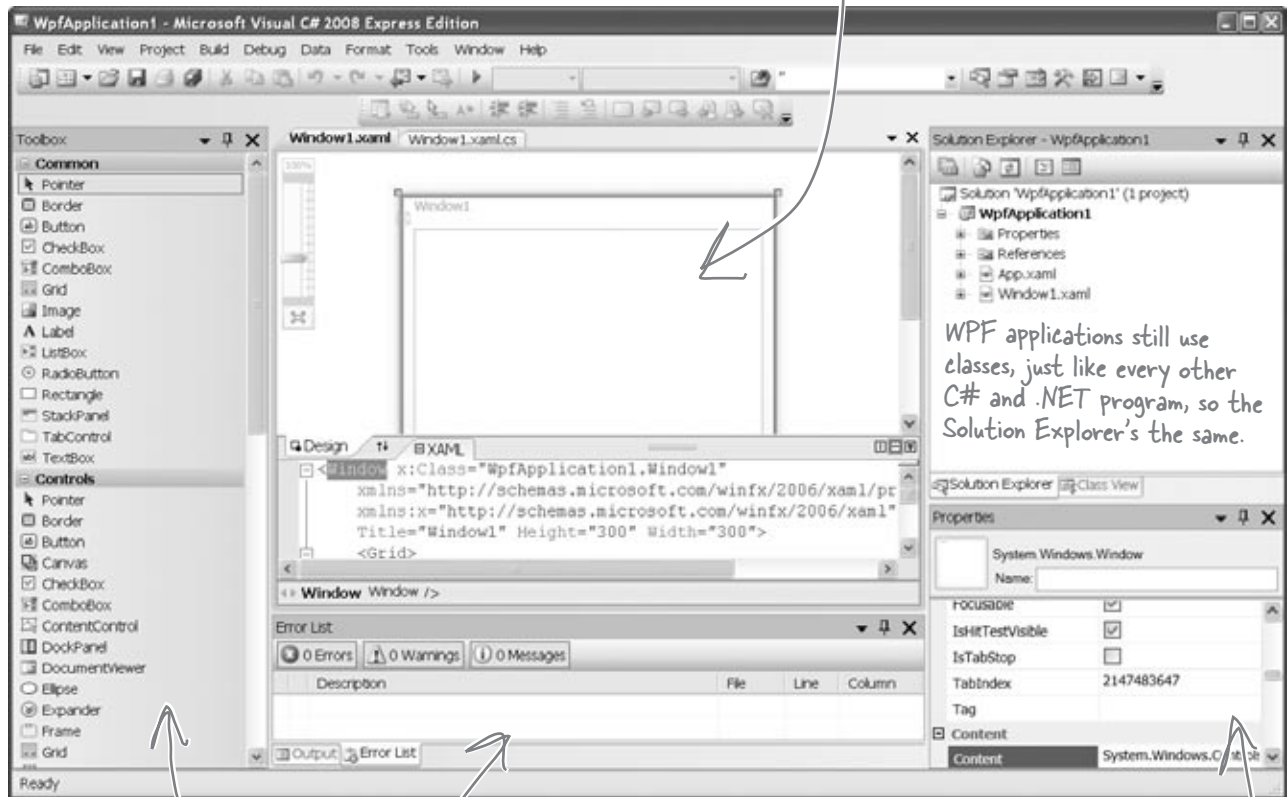

Drag a button out of the toolbox and onto the form. If this were a Windows Forms application, the IDE would add code to `Form1.Designer.cs` to add a control to the `Form1` object. But WPF is different—it uses an XML-based language called XAML to define how the user interface is laid out.

Drag this slider up and down to zoom in and out. When you zoom in really close, your user interface still looks good—it doesn't get pixelated.

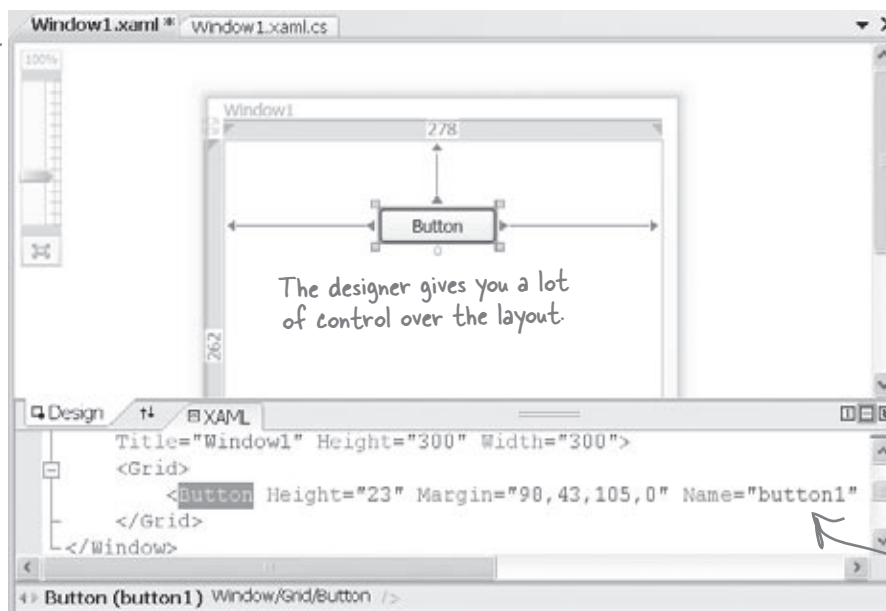

The designer gives you a lot of control over the layout.

XAML stands for "Extensible Application Markup Language," and it's the XML-based language that WPF applications use to determine where all of the controls go and other UI elements go.

The IDE has a really powerful XML editor that's optimized for working with XAML.

Go to the XML editor and add a second button by typing the **bold** line below into the XAML editor. You'll notice how the IDE's IntelliSense does a good job of helping you enter all the XML tags.

```
<Grid>
  <Button Height="23" Margin="98,43,105,0" Name="button1"
    VerticalAlignment="Top" Click="button1_Click">Button</Button>
  <Button Height="23" Margin="5,5,100,20" Name="button2"
    VerticalAlignment="Top" Click="button2_Click">Another button</Button>
</Grid>
```

When you get to the "`Click="button2_Click"`" part of the line, don't type in the name of the event handler. Instead, use the IntelliSense window that pops up to tell the IDE to add a new event handler. As soon as you finish the line, you'll see a new button appear in the designer. Switch over to the `Window1.xaml.cs` tab, and you'll find a new `button2_Click` method there.

That's all the WPF and XAML that we can include here. But now that you've got the tools to start learning about WPF, we definitely recommend that you take a look at ***Programming WPF*** by Chris Sells and Ian Griffiths. It's available from the O'Reilly website: <http://www.oreilly.com/>.



Did you know that C# and the .NET Framework can...

- ★ Give you much more power over your data with advanced LINQ queries? Serialize objects to an XML file?
- ★ Access websites and other network resources using built-in classes?
- ★ Let you add advanced encryption and security to your programs?
- ★ Create complex multithreaded applications?
- ★ Let you deploy your classes so that other people can use them?
- ★ Use regular expressions to do advanced text searching?



I had no idea! Where can I learn more?

There's a great book that explains it all! It's called **C# 3.0 in a Nutshell** by Joseph Albahari and Ben Albahari, and it's a thorough guide to everything that C# has to offer. You'll learn about advanced C# language features, you'll see all of the essential .NET Framework classes and tools, and you'll **learn more** about what's really going on under the hood of C#.

Check it out at <http://www.oreilly.com/>.

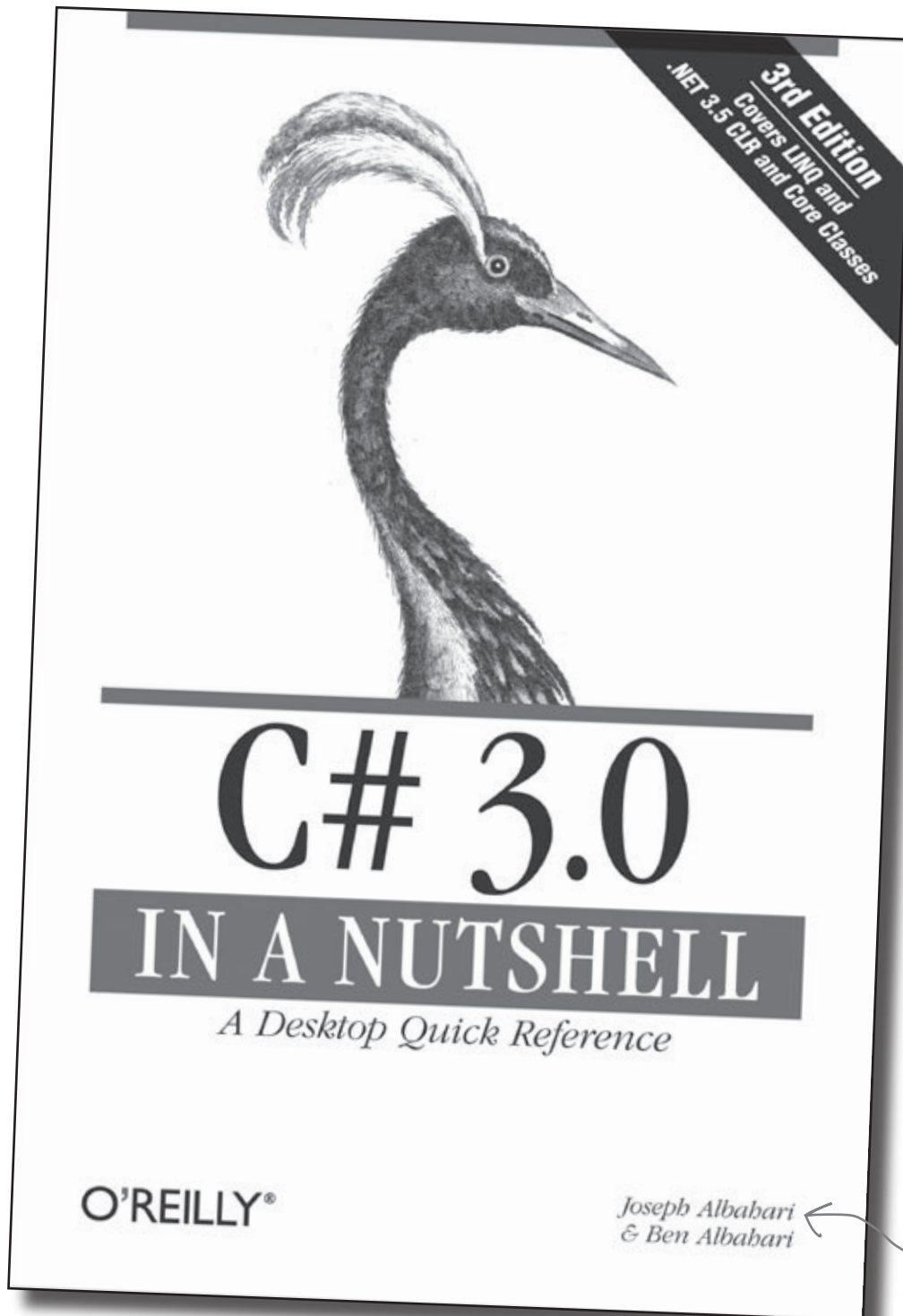

Joseph Albahari helped us out a whole lot by giving this book a really thorough tech review. Thanks so much for all your help, Joe!

Joseph Albahari
& Ben Albahari



Index

Symbols

!= operator 68
&& operator 68, 77
*= operator 64, 136
* operator 64
+= operator 64
+ operator 64
 casting 129
-= operator 136
- operator 64
// (slashes) 66
/ operator 64
< operator 68
== operator 67, 68
= operator 64, 67
> operator 68
@ in front of filenames 389, 401
\n 15, 66, 401
\t 401
|| operator 68

A

abstract classes 278–285
 Fireside Chat 284–285
 usefulness 279–280
abstraction as principle of OOP 288
abstract keyword 281
abstract methods 278, 281
access modifiers 273–274
 internal 273
 private 273

 protected 273
 protected versus private or public 276
 public 273
 scope 274
 sealed 273
Adventure Game program (see labs, #2 The Quest)
Albahari, Joe 706
allocate, defined 405
allocated resources 405
Anatomy of a program 52–53
 .NET Framework 52
 classes 52, 53
 methods 52, 53
 namespaces 52
 parameters 53
 statements 53
 using lines 52
Anatomy of a query 660
AND operator 68
animal inheritance program 216–222
animation 566–567
 building control 573
 double buffering 608–613
AppendAllText() method 400
Appliance project 266–270
 Appliance class 266
 downcasting 268
 interfaces 269
 upcasting 267
 interfaces 269
application design (see design)
applications
 compiling 47
 console 710–711
 debugging 47

applications (*continued*)
 deploying 37, 38
 running 36
 running in IDE 36

architecture 531

args parameter 711

argument 130

arrays 148–149, 262
 deck of cards 315–316
 finding length 149
 versus Lists 318–320, 325

assemblies 273

attributes 421

B

BackColor property 51

BackgroundWorker 708

backing field 193, 198

Baseball Simulator project 484–501
 callbacks 507–509
 Fan class 494–497
 Pitcher class 494–497
 subscription and public events 505

base classes 214, 217
 colon (;) 222
 constructors 233
 extending 221
 subclasses accessing with base keyword 232
 upcasting 267
 using subclasses instead 227

base keyword 232, 275

Beehive Simulator project 239–249, 252–265
 adding new form 544
 AnimateBees() method 613
 animating with controls 566–567
 building control 573–575
 images 574–575
 timer 575
 Bee class 524–525
 Go() method 533–535, 542–543

BeeControl 574–579
 animating bees on form 580–581
 creating button to add to form 576
 creating from UserControl 578
 disposing 577
 implementation 579
 ResizeCells method 591
BeeState enum 525–527
Bitmap class 593
building form 241
building Worker and Queen classes 241
class hierarchy with Worker and Queen classes 253
collection of bees 555
Color.Transparent 589
creating Bee class 246
DateTime class 548
Dictionary objects 569
double buffering 609–613
drawing picture on form 596–597
encapsulation 537
extending through inheritance 245–249
fixing transparency problems 601
Flower class 520–522
for loops 537
forms
 adding hive and field 582
 clearing out all controls 583
 FieldForm 586–587
 FormBorderStyle property 582
 HiveForm 586–587
 Location property 582
 Reset button 587
Graphics object 592
Hive class 529–530
 adding methods 532–533
 exceptions 539
 updates 540–541
honey production 246
interfaces 254–263
 inheritance 263
 references 260–261
making Queen class inherit from Bee class 247
making Worker class inherit from Bee class 247
NectarHarvested variable 523
number of bees 533

- object model 518
 - OutOfHoneyException 468
 - overview of what's to be added 519
 - Paint event handler 602
 - performance issues 589–591
 - Point object 539
 - printing 616–619
 - code for the Print button 619
 - event handler for the Document's PrintPage event 618
 - PrintTableRow() method 618
 - read-only automatic properties 523
 - RemoveAllControls() method 583
 - removing dead flowers and retired bees 537
 - Renderer 568–569
 - Renderer class 583–585
 - DrawBees() 584
 - DrawFlowers() 584
 - GetBeeControl() 585
 - MoveBeeFromFieldToHive() 585
 - MoveBeeFromHiveToField() 585
 - RemoveRetiredBeesAndDeadFlowers() 585
 - ResizeImage method 591
 - resizing images 592–593
 - Show() method 587
 - timers 546
 - adding to program 548
 - disposing 577
 - events and delegates 547
 - Render() method 583
 - ToolStrip control, adding Open, Save, and Print 559
 - updating form to instantiate bees 247
 - using World to get statistics 545
 - World class 534–535
 - code 536
- behavior 12
- Behind the Scenes
- how forms and controls repaint themselves 605
 - LINQ using extension methods 657
 - The stack vs. the heap: more on memory 641
 - Unicode 424
 - visual components 576
- binary and decimal, converting between 125
- binary files 424
 - comparing 429
 - hex dump 431
 - working with 431
 - writing 427
- BinaryFormatter 420
 - Deserialize() method 420, 423
 - Serializable attribute 423
 - SerializationException 454
- BinaryReader 428
- BinaryWriter 427
- Birthday Party project 206–214
 - BirthdayParty.CalculateCost() 213
 - BirthdayParty class 207
 - CakeWriting method 212
 - CalculateCost() method 212
 - inheriting from Party class 234–238
- Bitmap class 593
- blank space 66
- boilerplate code 44
- bool type 63, 64, 124, 126
- bound 32
- boxed objects and structs 642, 644
- boxed struct 645
- breakpoints 450
 - knowing where to put 452
- BringToFront() method 581
- Brush object 606
- Build menu 47
- Build Solution 47
- built-in features 55
- Bullet Points
 - delegates 509
 - event handlers 509
 - exception handling 471
 - LINQ query statements 664
 - Lists 322

Bullet Points (*continued*)

- reference variables 154
- statements 73
- try/catch blocks 471
- types 154

buttons 44

- adding code to interact with objects 113
- adding to form 51, 112
- BackColor property 51
- Name property 51
- Size property 51
- Text property 51

byte arrays 401

- moving text around in 426

byte order mark 434

byte type 124, 126

C

C#

- what you can do with 714
- what you get with Visual Studio and 2
- why you should learn 2

C# 3.0

- automatic properties 195
- object initializers 115

Calculator program 474–475

- temporary solution 475

callbacks 507

- versus events 510

call stack 453

camelCase 201

Candy Control System 102–108

capitalization 201

Captain Amazing 622–626, 635, 636, 645, 651

casting 128–130

- + operator 129
- automatic 130
- wrapping numbers 129

catch blocks 455, 457

- followed by (Exception) 460
- following in debugger 458–459
- multiple 466
- with no specified exceptions 462

chaining 491, 499

Character Map 424, 425

char type 125, 126

checkbox 75

class diagrams 90, 104, 106

- moving up, not down 231
- private fields and types 240

classes 52, 53, 73

- abstract (see abstract classes)
- adding 56
- collection 317
- concrete 278
- copying 90
- creating example 111
- curly braces 66
- declaration 54
- defining 66
- designing intuitive classes 116
- finding out if class implements specific interface 262
- instances (see instances)
- internal 273
- looking for common 219
- members 273
- message about adding components to my class 579
- MessageBox 56
- multiple in same namespace 61
- naming 102–103
- natural structure 104
- never instantiated 277
- organizing 106
- partial (see partial classes)
- private 273
- protected 273
- public 273
- sealed 273
- serializable 421

- similarities between 116
- static 97
- subscribing 489
- using to build objects 92
- versus structs 644
- why some should never be instantiated 280
- you can't inherit from 647
- class hierarchy 215, 220
 - Hive Simulator 253
- Clone class
 - implementing IDisposable 630, 631
- CLR (Common Language Runtime) 47, 153
- code
 - avoiding duplication 217
 - blocks 73
 - boilerplate 44
 - copying 90
 - looking at auto-generated 15
 - renaming things in code 707
 - repeating 213
 - similar 214
 - unwanted code from IDE 11
 - using IDE to help write code 48–49
- collection initializers 326–327
- collections 317, 555
 - Dictionary (see dictionaries)
 - generic 325
 - LINQ 556–558
 - List (see lists)
 - performing calculations on 662
 - Queue (see queues)
 - Stack (see stack)
 - using join to combine two collections into one query
 - 671, 672
 - versus tables 661
- colon (:) 222
- colon operator 256
- Color.Transparent 589
- colors 76
- columns 20
- command-line arguments 711
- comments 66
- CompareTo() method 329
- compiler 47
- compiler errors
 - interfaces 254
 - troubleshooting 49
- compiling application 36, 47
- compound operators 136
- concatenation 130
- concrete classes 278
- conditional expressions, consolidating 707
- conditional operators 68–70
- conditional tests 68–70, 73
- configuration files 37
- Console.WriteLine() method 194
- console applications 710–711
- console window, debugging in 711
- constructors 197, 198, 199
 - base class 233
 - building new with switch statement 415
 - exceptions in 459
 - subclasses 233
- ContactDB.mdf 18, 29, 31
- ContactDBDataSet 31, 32
- ContactDBDataSet.Designer.cs 31
- ContainsKey() method 581
- controls
 - adding code 564
 - altering reexisting 587
 - animating Behive simulator 566–567
 - as objects 565
 - bound to database 32
 - clearing out all on forms 583
 - custom 564
 - animation 573
 - disposable objects 577
 - database-driven 32–33
 - disposing 577, 579

controls (*continued*)
 how forms and controls repaint themselves 605
 redrawing themselves 602
 removing 564
 visual display elements 570

Controls collection 565

count ++ 64

count -- 64

count = 64

Create() method 400

CreateDirectory() method 400

CryptoStream 394

curly braces 66, 73

curly brackets 58, 111

 single-line blocks 212

D

data

 pulling data from multiple sources 656
 storing categories of 310

database-driven controls 32–33

database diagram 26

 saving 27

Database Explorer 18, 675

databases 3

 adding table 20
 adding to project 18
 connecting forms to 17, 30
 (see also data source)
 connecting LINQ to SQL database 674–675
 entering data 28–29
 LINQ 673
 LINQ querying SQL database 677
 multiple tables 26
 SQL 18, 19
 SQL Server Express 7

data source

 adding new 30
 configuring 31
 database-driven controls 32

Data Source Configuration Wizard 18

data storage 7

data types 20

 generic 325

DateTime class 548

debugger

 Break All button 449

 Bullet Points 471

 catch blocks

 followed by (Exception) 460

 following flow 458–459

 multiple 466

 with no specified exceptions 462

 Continue button 449

 exploring delegates 503

 finally block 460

 knowing where to put breakpoints 452

 Restart button 449

 Show next statement button 449

 Step into button 449

 Step Into command 450

 Step out button 449

 Step over button 449

 try blocks 458–459

 unhandled exception window 452

 uses for 457

 Watch window 449, 457

 running methods in 452

 (see also exception handling)

debugging 16, 47, 449

 console window 711

 Excuse Management program 450–451

Debug menu 47

decimal and binary, converting between 125

- decimal type 125, 126
 - declaration 54
 - delay 76, 79
 - delegates
 - Bullet Points 509
 - defined 501
 - exploring in debugger 503
 - hooking up to one event 507–509
 - in action 502–503
 - multiple events 499
 - Delete() method 400
 - deploying application 37, 38
 - deployment package 7
 - design 531
 - intuitive applications 34–35
 - intuitive classes 116
 - making code intuitive with class and method names 102–103
 - professional looking applications 35
 - user’s needs 5
 - destructor 628
 - dialog boxes 398–400
 - as objects 399
 - customized 401
 - popping up 397
 - DialogResult 397–399
 - excuse management program 410
 - dictionaries 335–337
 - Add() method 335
 - adding or removing items 336
 - ContainsKey() 335
 - getting list of keys 336
 - getting list of values 336
 - keys 335
 - keys and values 337
 - looking up values using keys 336
 - renderer 580
 - Dictionary objects 569
 - Dinner Party Planning project 174–185
 - CalculateCostOfDecorations() method 184
 - cost estimate 175
 - DinnerParty class
 - class diagram 176
 - exercise solution 178–179
 - fixing calculator 203–204
 - inheriting from Party class 234–238
 - numericUpDown control 183
 - recalculating new individual costs 183
 - directories
 - creating new 400
 - deleting 400
 - getting list of files 400
 - Dispose() method 406, 577
 - finalizers 632, 634
 - making object serialize in 633
 - using statement 630–632
 - DivideByZero error 443
 - DivideByZeroException 443, 448
 - dividing any number by zero 443
 - DogCompetition class 312
 - double buffering 608–613
 - double type 125, 126
 - downcasting 268, 269
 - failure 270
- ## E
- encapsulation 183–204, 435, 644
 - as principle of OOP 288
 - automatic properties 195
 - better 276
 - defined 185
 - example 192
 - ideas for 191
 - properties 193
 - Renderer 568
 - entry point 55, 58, 231
 - changing 56
 - enumeration 310–311
 - enums 311–315
 - big numbers 312
 - representing numbers with names 312
 - versus Lists 325

- equal signs 67
- error handling 462
- Error List 49, 58
- errors
 - avoiding file system errors with using statements 406
 - compiler errors and interfaces 254
 - DivideByZero 443
 - invalid arguments 131
 - You must rebuild your project for the changes to show up in any open designers. 579
- escape sequence 66
- EventHandler 488, 491
 - using methods that do match others defined by EventHandler 491
- event handlers 177, 188, 485
 - adding 491
 - automatic 492–493
 - Bullet Points 509
 - excuse management program 408
 - hooking up 498
 - how they work 486–487
 - printing 614
 - returning something other than void 491
 - types of 491
- event keyword 488
- events
 - callbacks 507–509
 - connecting senders with receivers 500
 - defined 485
 - delegates 499
 - forms 498
 - how they work 486–487
 - naming methods when raising events 490
 - raising 490
 - raising events with no handlers 490
 - reference variables 500
 - subscription and public events 505
 - versus callbacks 510
 - (see also event handlers)
- exception, defined 444
- exception handling 439–482
 - Bullet Points 471
 - catch block 455, 457
 - catching specific exception types 473
 - DivideByZeroException 443, 448
 - dividing any number by zero 443
 - exceptions in constructors 459
 - exceptions versus unhandled exceptions 462
 - Excuse Management program 477–478
 - FileNotFoundException 462
 - finalizers 635
 - FormatException 448
 - handling, not burying 474
 - handling versus fixing 475
 - IDisposable interface 472
 - IndexOutOfRangeException 448
 - IOException 460
 - NullReferenceException 443
 - OverflowException 448
 - program stopping with exceptions 462
 - SerializationException 453, 460
 - simple ideas for 476
 - specifying particular kinds of exceptions 462
 - spotting exceptions 445
 - throwing and catching exceptions 467
 - try block 455, 457
 - unexpected input 456
 - unhandled exceptions 452
 - using exceptions to find bugs 447
 - using statement 471
 - why there are so many exceptions 445
 - (see also debugger)
- Exception objects 444, 445
 - inheriting from Exception class 448
 - Message property 466
 - using to get information about the problem 465
- Excuse Management project 407–411
 - binary files with serialized objects 436
 - building the form 408
 - code problems 453
 - debugging 450–451
 - Random Excuse button 461

- DialogResult 410
- event handlers 408
- exception handling 477–478
- Folder button 408
- Random Excuse button 411
- Save As dialog 410
- solution 410–411
- unexpected user behavior 446–447
- using debugger to follow try/catch flow 458–459
- executable file 47
- executing application 36
- Exists() method 400
- Expand Tables 28
- extension methods 646, 647
 - LINQ 657
 - strings 648

F

- Farmer class 192–198
 - constructors 197
 - fully encapsulating 195
 - testing 194–195
- features 3
 - built-in 55
- fields 98
 - backing field 193
 - initializing public fields 196
 - interfaces 255
 - lining up 34
 - masking 198
 - method's parameter has same name as a field 198
 - private 185–188
 - constructors 197
 - declaring 201
 - public 191
 - versus methods 98
 - versus properties 276
 - with no access 188
- File.Create() 429
- File.OpenWrite() 429
- File.ReadAllBytes() 425, 426, 434
- File.ReadAllLines() 434
- File.ReadAllText() 434
- File.WriteAllBytes() 425, 426, 434
- File.WriteAllLines() 434
- File.WriteAllText() 434
- File class
 - Close() method 434
 - ReadAllText() method 403
 - static methods 434
 - versus FileInfo class 434
 - WriteAllText() method 403
- FileDialogs 403
- FileInfo class 400
 - versus File class 434
- filenames, @ in front of 389
- FileNotFoundException 462
- files
 - appending text to 400
 - finding out if exists 400
 - get information about 400
 - reading from or writing to 400
 - (see also streams)
 - where Visual Studio stores them 16
 - writing 412
- FileStreams 387, 388
 - BinaryWriter 427
 - StreamWriter 389
 - versus StreamReader and StreamWriter 434
- FileSystemWatcher 709
- Filter property 398
- finalizers 628
 - Dispose() method 632, 634
 - exceptions 635
 - fields and methods 635
 - garbage collection 629–631
 - references 632
 - stability 632
 - when they run 629
- finally block 460

Fireside Chats

- abstract classes 284–285
- Dispose() method and finalizers 634

Five Minute Mystery

- The Case of the Golden Crustacean 506
- mystery solved 511

flickering images 607

float type 124, 126

- assigning 129

foreach loop (lists) 321, 358

for loops 65, 69

Form1.cs 8

Form1.Designer.cs 8, 45, 50

- changing control properties 12

Form1.resx 14

Form1 form, programs without 231

FormatException 448

FormBorderStyle property 582

Form Designer 3

forms

- adding buttons 112
- adding method 113
- adding variables 112
- as objects 152–153
- connecting to databases 17, 30
 - (see also data source)
- CreateGraphics() method 594
- database-driven controls 32
- events 498
- how forms and controls repaint themselves 605
- OnPaint method 605
- Paint event 605
- PaintEventArgs 605
- redrawing themselves 602
- Refresh() method 605
 - (see also Beehive Simulator project, forms)

frames versus turns 549

from clause 664, 667

FromImage() 606

G

garbage collection 140, 153, 635

- finalizers 629–631

GDI+ 594–595

generic collections 325, 355

generic data types 325

get accessor 193, 199

- interfaces with get accessor without set accessor 259

GetFiles() method 400

GetLastAccessTime() method 400

GetLastWriteTime() method 400

Go To Definition 405

GPS navigation system 87

graphical user interface (see GUI)

graphics

- drawing picture on form 596–597
- how forms and controls repaint themselves 605
- Rectangle 597
- using keyword 606

Graphics object 592, 594, 606

- CreateGraphics() method 595

DrawBee() method 601

DrawCircle() method 595

DrawString() method 595

FillCircle() method 595

Invalidate() controls 605

Paint event handler 602

printing 614

Update() method 605

green arrow button 16

GroupBox control 207, 606

group keyword 667, 668

GUI (Graphical User Interface) 94

- labs, #1 A Day at the Races 170

guys (Two Guys project) 110–115, 117–118

building form

- adding a method 113
- adding buttons 112

- adding code to interact with objects 113
- adding variables 112, 113
- creating Guy class and two instances 110
- sample code 111

GZipStreams 387

H

heap 100, 101

- garbage collection 140
- structs 637
- versus stack 641

Hebrew letters 425

hex dump 431

- StreamReader and StreamWriter 433
- using file streams to build hex dumper 432

hexadecimal 431

- working with 432

hierarchy 215

- defined 221

I

IClown interface 258

- access modifiers 274–275
- extending 271–272

IComparable interface 329

IComparer interface 330

- complex comparisons 332
- creating instance 331
- multiple classes 331
- SortBy field 332

IDE

- auto-generated code 73
- behind the scenes 14
- buttons 44
- changing names of files 11
- changing things in 50
- compiler errors, troubleshooting 49
- creating new projects 8
- Error List 49
- green arrow 16

helping users code 48–49

importing images 14

making changes in 45

New Project window 8

Properties window 44

renaming things in code 707

Reset Window Layout command 11

running program in 36

SQL statements 19

stored procedures 19

unwanted code 11

using tabs to switch between open files 48

visual tools 73

what it does in typical application 44–45

what the IDE automates 2

where data is stored 29

Windows Forms Application project 44

XAML 713

IDE toolbar

green arrow button 16

Save icon 15

Stop Debugging button 16

IDisposable interface 405, 473, 630

avoiding exceptions 472

IDs

auto-generated 21

unique 20

if/else statements 67

if statements 131

images

drawing picture on form 596–597

fixing transparency problems 601

flickering 607

performance issues 590

Rectangle 597

resizing 592–593, 606

TrackBars to zoom an image in and out 603–604

images, importing 14

index (arrays) 148–149

IndexOutOfRangeException 448

infinite loops 71

- inherit, defined 215
 - inheritance 213–250
 - as principle of OOP 288
 - avoiding duplication of code 217
 - classes you can't inherit from 647
 - class hierarchy, Hive Simulator 253
 - class that contains entry point 231
 - looking for common classes 219
 - multiple 286
 - passing instance of subclass 231
 - subclasses 225–226
 - (see also interfaces)
 - InitialDirectory property 398
 - initialization 115
 - InitializeComponent() method 198
 - installation, testing 39
 - instances 93
 - creating 94
 - example 111
 - heap 101
 - static keyword 99
 - defined 93
 - fields 98
 - keeping track of things 98
 - non-static methods 97
 - instantiation, interfaces 260
 - int 63
 - integers, using in code 137
 - IntelliSense window 577, 595
 - CreateGraphics() method 606
 - interface keyword 255
 - interfaces 254–276
 - colon operator 256
 - compiler errors 254
 - containing statements 270
 - downcasting 269
 - easy way to implement 270
 - example code 258
 - fields 255
 - finding out if class implements specific interface 262
 - get accessor without a set accessor 259
 - implementing 257–258
 - inheriting from other interfaces 263
 - is keyword 262, 265
 - like contracts 270
 - naming 254
 - new keyword 260
 - object references versus interface references 276
 - properties 255
 - public 255
 - public void method 259
 - references 260–261
 - why use 276
 - upcasting 269
 - void method 258
 - why use 270, 276
 - internal access modifier 273
 - int type 124, 126, 127
 - assigning value 137
 - declaring 137
 - invalid arguments error 131
 - IOException 460
 - is keyword 262, 265
- ## J
- join clause 671, 672, 677, 678
- ## L
- labels 75
 - lining up 34
 - labels for objects (see reference variables)
 - labs
 - #1 A Day at the Races
 - application architecture 168
 - Bet class 167
 - Bet object 169
 - Betting Parlor groupbox 171
 - dogs array 168

- finished executable 172
- Greyhound class 166
- Greyhound object initializer 166
- GUI 170
- Guy class 167
- Guy object 169
- guys array 168
- PictureBox control 166, 168, 170
- RadioButton controls 168
- this keyword 167
- #2 The Quest 363–384
 - Bat subclass 377
 - BluePotion class 380
 - Bow subclass 379
 - Enemy class 376
 - Enemy subclasses 377
 - form, bringing it all together 381–383
 - form, building 366–367
 - form, UpdateCharacters() method 382
 - Game class 370–371
 - Ghost subclass 377
 - Ghoul subclass 377
 - IPotion interface 380
 - Mace subclass 379
 - Mover class 372–373
 - Mover class source code 373
 - Player class 374
 - Player class Attack() method 375
 - Player class Move() method 375
 - RedPotion class 380
 - Sword subclass 379
 - using objects 368–369
 - Weapon class 378
- #3 Invaders 681–702
 - additions 701
 - animation timer 687
 - architecture 684–685
 - designing the form 686–690
 - Form object 684
 - Game class 692
 - Game class, filling out 694
 - Game class methods 693
 - Game object 684–685
 - Game object's Draw() method 691
 - gameOver event 689
 - game timer 689, 690
 - graphics 691
 - Invader class 696
 - Invader class methods 697
 - KeyDown andKeyUp events 688
 - LINQ 695
 - movements 683
 - Paint event handler 691
 - PlayerShip class 698
 - PlayerShip object 685
 - Shot objects 699
 - Stars class 700
 - Stars object 685
 - types of invaders 683
- line break 15, 66
- LINQ (Language INtegrated Query) 556–558
 - 101 LINQ Samples 663
 - combining results into groups 667, 668
 - connecting to SQL database 674–675
 - databases 673
 - extension methods 657
 - from clause 664, 667
 - Invaders lab 695
 - modifying items 662
 - .NET collections 657
 - orderby clause 664, 667
 - performing calculations on collections 662
 - pulling data from multiple sources 656
 - queries 658, 663
 - querying SQL database 677
 - query statements 664
 - scouring comic collections 659
 - select clause 664
 - Take statement 664
 - to XML 704–705
 - reading RSS feed 705
 - using join to combine two collections into one query 671, 672
 - versus SQL 661
 - where clause 664
- LINQPad 679
- lists 317–334
 - Bullet Points 322
 - CompareTo() method 329

lists (*continued*)

- converting from stacks or queues 358
- creating new 325
- dynamically shrinking and growing 321
- foreach loop 321
- IComparable interface 329
- IComparer interface 330
 - complex comparisons 332
 - creating instance 331
 - multiple classes 331
- Sort() method 328
- sorting 328–329
- storing types 322
- things you can do with 318
- versus arrays 318–320, 325
- versus enums 325

literals 125

Location property 582

logical operators 68

long type 124, 126

loops 65, 69

- infinite 71
- nested 77

lowercasing 201

M

Main() method 54, 55

masking fields 198

Math class 66

Maximize and Minimize buttons 35

MaximizeBox property 35

members (class) 273

memory 100

MemoryStreams 387

message about adding components to my class 579

MessageBox 56

methods 15, 52, 53

- abstract 278, 281
- adding for form 113

calling specific 221

curly braces 66

declaration 54

defining 66

entry point 54, 55

extension (see extension methods)

extracting 706

implementing interfaces 257–258

Main() 54, 55

naming 102–103

objects 92

overloaded (see overloaded methods)

overriding 218, 226

parameter has same name as a field 198

private 187–188

public 191

- accessing private fields 188

- capitalization 201

return values 88

set and get accessors 199

Show() 56

static (see static methods)

variables matching types of parameters 131

versus fields 98

with no return value 197

MinimizeBox property 35

multiple inheritance 286

N

Name property 51

namespaces 46, 52, 55

- multiple classes in same 61

- reserved 73

Navigation project 86–98

nested loops 77

.NET collections, LINQ 657

.NET Database Objects 6

.NET Framework 46

- colors 76

- Random class 150–151

- tools 52
 - what you can do with 714
- .NET Visual Objects 6, 17
- NetworkStreams 387
- new keyword 91
 - interfaces 260
- No Dumb Questions
 - @ in front of filenames 401
 - \n 15, 401
 - \t 401
 - Beehive Simulator project
 - BeeControl 579
 - for loops 537
 - Go() methods 533
 - Hive class exceptions 539
 - NectarHarvested variable 523
 - number of bees 533
 - Point object 539
 - read-only automatic properties 523
 - removing dead flowers and retired bees 537
 - Show() method 587
 - BirthdayParty class 207
 - boxed objects and structs 644
 - byte order mark 434
 - capitalization 201
 - catch block 457
 - with no specified exceptions 462
 - chaining 491
 - changing names of files generated by IDE 11
 - changing types 154
 - class diagrams, moving up, not down 231
 - classes 73
 - versus structs 644
 - Close() method 434
 - closing streams 401
 - columns 20
 - constructors 198, 199
 - controls, altering reexisting 587
 - converting strings to byte array 401
 - creating new Lists 325
 - curly brackets 58
 - customized dialog boxes 401
 - data types 20
 - debugger 457
 - Watch window 457
 - easy way to implement interfaces 270
 - encapsulation 188, 276
 - entry point 58, 231
 - error handling 462
 - Error List 58
 - errors, You must rebuild your project for the changes
 - to show up in any open designers. 579
 - EventHandler 491
 - event handlers 188
 - adding 491
 - returning something other than void 491
 - types of 491
 - events versus callbacks 510
 - Exception object 445
 - exceptions versus unhandled exceptions 462
 - extension methods 647
 - fields with no access 188
 - File class versus FileInfo class 434
 - FileStreams versus StreamReader
 - and StreamWriter 434
 - finalizers
 - exceptions 635
 - using fields and methods 635
 - forms as objects 153
 - frames versus turns 549
 - from clause 664
 - FromImage() 606
 - garbage collection 153, 635
 - generic collections 325
 - generic data types 325
 - get accessor 199
 - graphics, using keyword 606
 - Graphics object 606
 - guys (Two Guys project) 114
 - IDE
 - auto-generated code 73
 - where data is stored 29
 - IDE toolbar
 - green arrow 16
 - Reset Window Layout command 11
 - Stop Debugging button 16

No Dumb Questions (*continued*)

- IDisposable interface 473
- instances, non-static methods 97
- interface references, why use 276
- interfaces
 - containing statements 270
 - like contracts 270
 - why use 276
- join clause 677
- knowing where to put breakpoints 452
- line break 15
- LINQ 663
- LINQ querying SQL database 677
- Lists versus arrays 325
- Lists versus enums 325
- message about adding components to my class 579
- method 15
- namespaces, reserved 73
- new projects, Visual Studio 2008 11
- null keyword 153
- object references versus interface references 276
- OpenFileDialog, changing properties 579
- overloaded constructors 313
- partial classes 73
- patterns, callbacks 510
- Point 644
- private data 188
- program stopping with exceptions 462
- programs without Form1 form 231
- properties
 - statements 199
 - versus fields 276
- protected versus private or public 276
- record data 29
- reference variables, how they work 154
- resizing images 606
- select clause 664
- select new clause 677
- set accessor 199
- setting structs equal to another 644
- specifying particular kinds of exceptions 462
- spotting exceptions 445
- stack 644

- static and non-static methods 97
- static methods, when to use 97
- StreamReader 401
- StreamWriter 401
- subclasses
 - and base classes 222
 - passing instance of 231
- this variable 154
- try/finally block 473
- try block 457
- unhandled exceptions 452
- unhandled exception window 452
- Unicode 434
- unique IDs 20
- unwanted code from IDE 11
- upcasting, but not downcasting 270
- UserControl 606
- using methods that do match others defined
 - by EventHandler 491
- using statement 473
- using this keyword to raise event 491
- virtual methods 231
- Visual Studio Express 11
- Watch window, running methods in 452
- why there are so many exceptions 445
- why use interfaces 270

null keyword 153

NullReferenceException 443

NumericUpDown control 89

O

- object initializers 115, 196, 197
- object oriented programming (OOP) 288
- object references, versus interface references 276
- Object Relational Designer window 675
- objects 91
 - accessing fields inside object 185
 - accidentally misusing 184
 - assigning value 137
 - as variables 137

- boxed 642
- building from classes 92
- declaring 137
- encapsulation (see encapsulation)
- event arguments 488
- finalizers (see finalizers)
- garbage collection 140
- instances (see instances)
- knowing when to respond 484
- null keyword 153
- reading entire with serialization 420
- references 261
- reference variables (see reference variables)
- setting equal to value type 642
- states 418
- talking to other objects 152
- versus structs 639
- object type 125
- Objectville Paper Co. logo 13
- OOP (object oriented programming) 288
- OpenFileDialog 579
 - changing properties 579
 - initialFolder property 403
- OpenFileDialog control 398, 403
- OpenRead() method 400
- OpenWrite() method 400
- operators 64
 - compound 136
- orderby clause 664, 667
- OR operator 68, 410
- Oven class 266
- OverflowException 448
- overloaded constructors
 - excuse management program 408
- overloaded methods 313, 343
- override keyword 226
- overriding methods 218

P

- PaintEventArgs 605
- Paint event handler 602
- parameters 53, 88, 89
 - capitalization 201
 - same name as a field 198
- partial classes 45, 50, 53, 59–61, 73, 78
- PascalCase 201
- patterns
 - callbacks 508, 510
- Pen object 606
- PerformanceCounter 709
- performance issues
 - Beehive Simulator project 589–591
 - images 590
- PictureBox control 12
 - adding to form 50
 - double-clicking 15
 - labs, #1 A Day at the Races 166, 168, 170
 - transparent background 589
 - Zoom mode 13
- PictureBox control 217
- Point 581, 644
- polymorphism 289
 - as principle of OOP 288
- popping up dialog boxes 397
- primary key 20–24, 27
- Primary Key button 20
- PrintDocument object 614–615
- printing
 - Beehive Simulator project 616–619
 - Graphics object and event handler 614
- PrintPage event handler 615
- private access modifier 258, 273

private fields 185–188
 constructors 197
 declaring 201
private methods 187–188
Problem Up Close, recalculating new
 individual costs 183
Program.cs 8, 54
programs (see applications)
properties 98
 automatic 195
 encapsulation 193
 initializing public properties 196
 interfaces 255
 public, capitalization 201
 read-only 195, 196
 statements 199
 versus fields 276
Properties window 35, 44
protected access modifier 273
protected keyword 275
public access modifier 273
public fields 191
 initializing 196
public methods 191
 accessing private fields 188
 capitalization 201
public properties
 capitalization 201
 initializing 196
public void method 259
publish/ folder 38
Publish Contacts 37
Publish Wizard 37

Q

queries 19
 anatomy of 660
 editing with LINQPad 679

LINQ 658, 663
 using join to combine two collections into one
 query 671
queues 355
 converting to lists 358
 enqueueing and dequeuing 356
 foreach loop 358

R

Racetrack Simulator (see labs, #1 A Day at the Races)
Random class 150–151
randomizing results 150–151
read-only properties 195, 196
record data 29
refactoring 706–707
references
 interfaces 260–261
 objects 261
 versus values 638
reference variables 138–140, 500
 garbage collection 140
 how they work 154
 multiple 139
 multiple references and their side effects 142
 multiple references and unintentional changes 147
 objects talking to other objects 152
Refresh() method 605
RemoveAllControls() method 583
render, defined 568
Renderer class 568–569, 583–585
 animating bees on form 580–581
 dictionaries 580
 ResizeImage method 591
reserved words 154
Reset Window Layout command 11
Resource Designer 582
resource files 14
result += 64

- result = 64
- return statements 88
- return type 88
- return values 53, 88
- risky code 456–473
- RoboBee class 264
- robust, defined 454
- RSS feed, LINQ to XML 705
- S**
- SaveFileDialog control 399, 403
 - Title property 403
- Save icon 15
- sbyte type 124
- scope 274
- sealed access modifier 273
- select new clause 671, 672, 675–679
- select statement 664
- semicolons 66
- serialization 416–425
 - making classes serializable 421
 - making object serialize in Dispose() method 633
 - object states 418
 - reading and writing serialized files 429
 - reading entire object 420
 - serializing and deserializing deck of cards 422–423
 - serializing objects out to file 424
 - what happens to objects 417, 419
- SerializationException 453, 460
 - BinaryFormatter 454
- Server Explorer 18
- Service-Based Database 18
- set accessor 193, 199
 - interfaces with get accessor without set accessor 259
- Setup executable 37
- short type 124, 126, 127
- Show() method 56
- ShowDialog() method 397, 399
- similar behaviors 214
- similar code 214
- Size property 51
- slashes (//) 66
- Sloppy Joe’s Random Menu Item project 150–151
- solution (.sln) file 46
- Solution Explorer 18, 46, 48
- Sort() method 328
- SortBy field 332
- source code files 46
- Spy project 186–188
- SQL (Structured Query Language) 19
 - connecting LINQ to SQL database 674–675
 - LINQ querying SQL database 677
 - versus LINQ 661
- SQL databases 18, 19
- SQL Server Express
 - database 7
 - file 29
- stack 355, 644
 - converting to lists 358
 - foreach loop 358
 - popping items off 357
 - versus heap 641
- Starbuzz Coffee project 654–656
 - join clause 678–679
- Start Debugging 47
- statements 19, 53, 73
- static keyword 97
 - creating instances 99
- static methods 97
 - when to use 97
- static void Main() 55
- Step out button 449

- Step over button 449
 - Stop Debugging button 16
 - stored procedures 19
 - Stream object 386
 - StreamReader 393, 401
 - hex dump 433
 - versus FileStreams 434
 - streams 386
 - chaining 394
 - closing 401
 - different types 387
 - Dispose() method 406
 - forgetting to close 388
 - serializing objects 423
 - things you can do with 387
 - using file streams to build hex dumper 432
 - using statements 406
 - writing text to files 389
 - StreamWriter 389–393, 401
 - [0] and [1] 401
 - hex dump 433
 - versus FileStreams 434
 - Write() and WriteLine() methods 389
 - String.IsNullOrEmpty() 240
 - string literals 389, 401
 - strings 63
 - converting to byte array 401
 - extension methods 648
 - formatting 179
 - storing categories of data 310
 - string type 124, 126
 - concatenation 130
 - converting 130
 - structs 637
 - boxed 642, 645
 - Point 644
 - setting one equal to another 640, 644
 - versus classes 644
 - versus objects 639
 - Structured Query Language (see SQL)
 - subclasses 214, 221
 - accessing base class with base keyword 232
 - constructors 233
 - inheriting from base class 222
 - modifying 225–226
 - overriding methods 226
 - passing instance of 231
 - upcasting 267
 - using instead of base classes 227
 - subscription
 - how it works 486–487
 - public events 505
 - subscribing classes 489
 - switch statements 413–415
 - building new constructors with 415
 - syntax 66
 - System.Drawing 594
 - System.Windows.Forms 46, 89, 111
 - System.Windows.Forms.Control 576
 - System namespace, Math class 66
- ## T
- TabControl 207
 - Table grid 28
 - tables
 - adding columns 20
 - adding to database 20
 - finish building 25
 - multiple 26
 - saving 25
 - versus collections 661
 - Take statement 664
 - testing installation 39
 - Textbox control 89
 - Text property 51
 - changing 34
 - The Problem Up Close, recalculating new individual costs 183

this keyword 201, 274
 labs, #1 A Day at the Races 167
 using to raise event 491
 this variable 154
 Timer 579
 timer 575, 583
 disposing 577
 timers 546, 548
 events and delegates 547
 Title property 399
 Toolbox components 708–709
 BackgroundWorker 708
 FileSystemWatcher 709
 PerformanceCounter 709
 Toolbox controls, easier way to build 578
 ToString() method 130, 179
 TrackBars to zoom an image in and out 603–604
 try/finally block 473
 try blocks 455, 457
 following in debugger 458–459
 turns versus frames 549
 types
 object 125
 (see also value types)

U

uint type 124
 ulong type 124
 unexpected input 456
 unhandled exceptions 452
 versus exceptions 462
 Unicode 424, 434
 converting text to 425
 unique IDs 20
 unwanted code from IDE 11
 upcasting 267, 269
 but not downcasting 270

Up Close, access modifiers 274–275
 uppercasing 201
 user's needs 5
 UserControl 578, 606
 user interface 3
 developing 12
 ushort type 124
 using keyword, graphics 606
 using lines 52
 using statements 406, 473
 Dispose() 630
 exception handling 471

V

values versus references 638
 value types 124, 154
 bool (see bool type)
 byte (see byte type)
 casting 128–130
 changing 154
 char (see char type)
 decimal (see decimal type)
 double (see double type)
 float (see float type)
 int (see int type)
 long (see long type)
 sbyte 124
 short (see short type)
 string (see string type)
 uint 124
 ulong 124
 ushort 124
 variables matching types of parameters 131
 variables 62, 73, 126
 adding to form 112
 assigning 128
 assigning values 63
 declaring 66
 matching types of parameters 131

- variables (*continued*)
 - naming 136
 - reference (see reference variables)
 - value types (see types)
- var keyword 658
- vertical bars 410
- virtual keyword 226
- virtual machines 47, 153
- virtual methods 231
- visual components 576
- visual display elements 570
- Visual Studio, what you get with C# and 2
- Visual Studio 2008, new projects 11
- Visual Studio 2008 Express 11
 - downloading xxxvi
 - setting up xxxvi
- Visual Studio Integrated Development Environment (see IDE)
- void method
 - interfaces 258
 - public 259
- void return type 88, 103, 113

W

Watch it!

- = operator versus == operator 67
- automatic properties 195
- destructors and finalizers 628
- event handlers, hooking up 498
- exceptions in constructors 459
- LINQ 658
- LINQ queries 663
- method's parameter has same name as a field 198
- object initializers 115

- raising events with no handlers 490
- SerializationException 454
- Server Explorer versus Database Explorer 18
- things looking different in your IDE 8
- writing to files 429

where clause 664

while loops 65, 69, 73

white space 66

Windows calculator 125

Windows Forms Application project 44, 66

Windows installer 7

Windows Presentation Framework (WPF) 712–713

Write() method 401

WriteLine() method 401

X

XAML (Extensible Application Markup Language) 713

XML, LINQ to XML 704–705

- reading RSS feed 705

Y

yesNo = 64

Z

zooming, TrackBars to zoom an image in and out 603–604

Zoo Simulator project 216–222

- class hierarchy 220

- extending base class 221

- inheriting from base class 221

- overriding methods 218