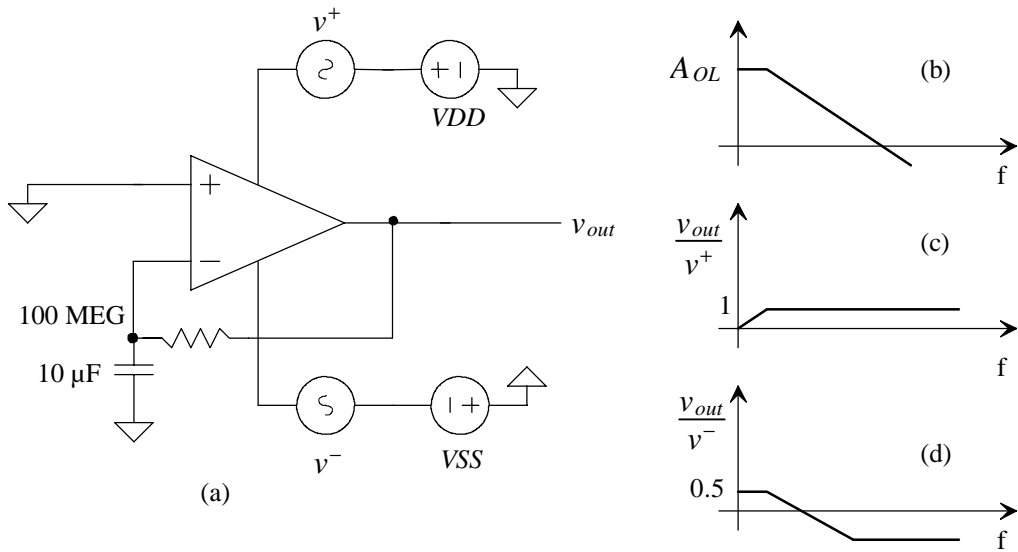

**Figure 25.13** Partial schematic of an op-amp showing the use of M13 as a process-insensitive resistor used for compensation.



**Figure 25.16** (a) Test setup to determine PSRR, (b) open-loop gain, (c) gain from AC signal on VDD to output, and (d) gain from AC signal on VSS to output.

