

Cascode Amplifier

Figure 1(a) shows a cascode amplifier with ideal current source load. Figure 1(b) shows the ideal current source is implemented by PMOS with constant gate to source voltage.

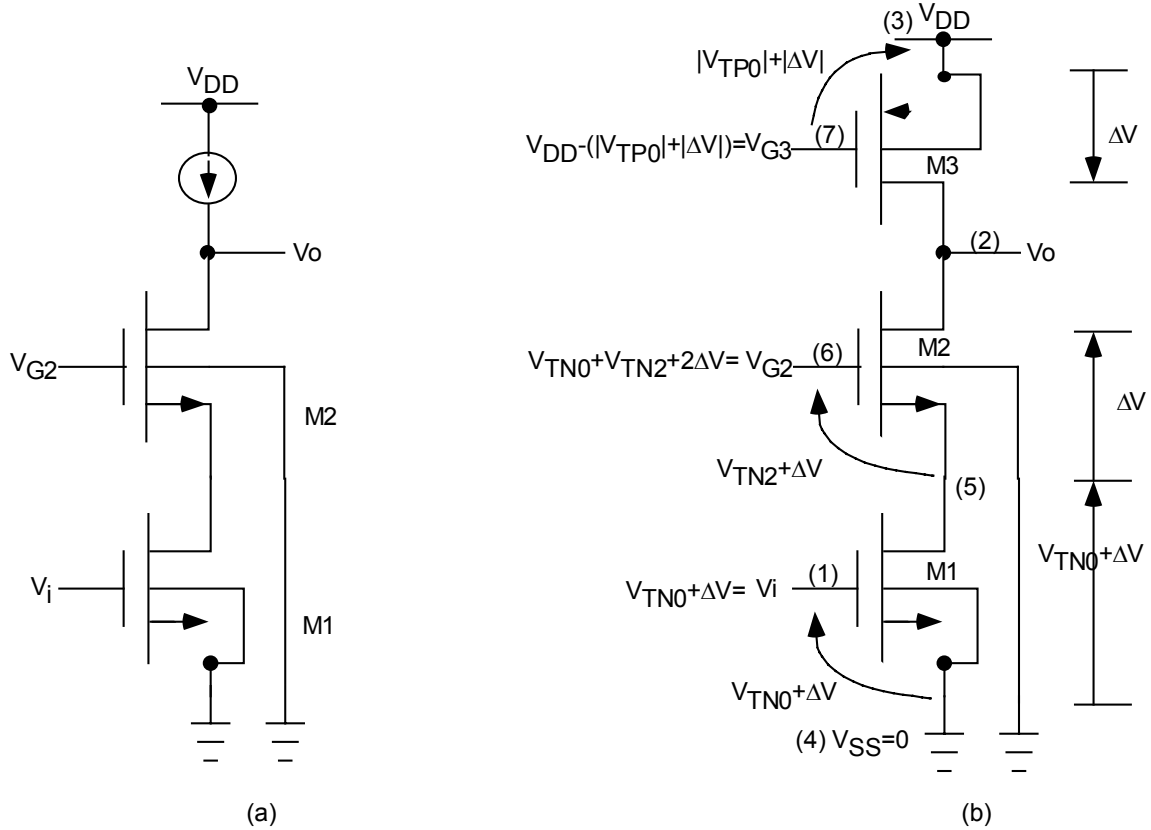

Figure 1. Cascode amplifier with simple current load.

1. Low Frequency Small Signal Equivalent Circuit

Figure 2(a) and 2(b) show its low frequency small signal equivalent circuit. Figure 2(c) shows its two-port representation and port variables assignment.

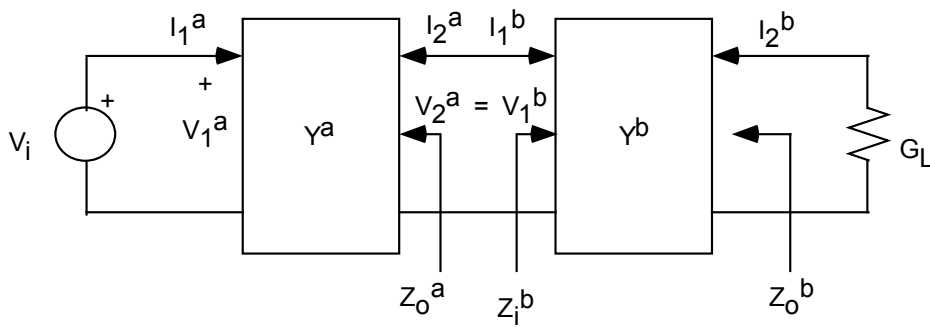
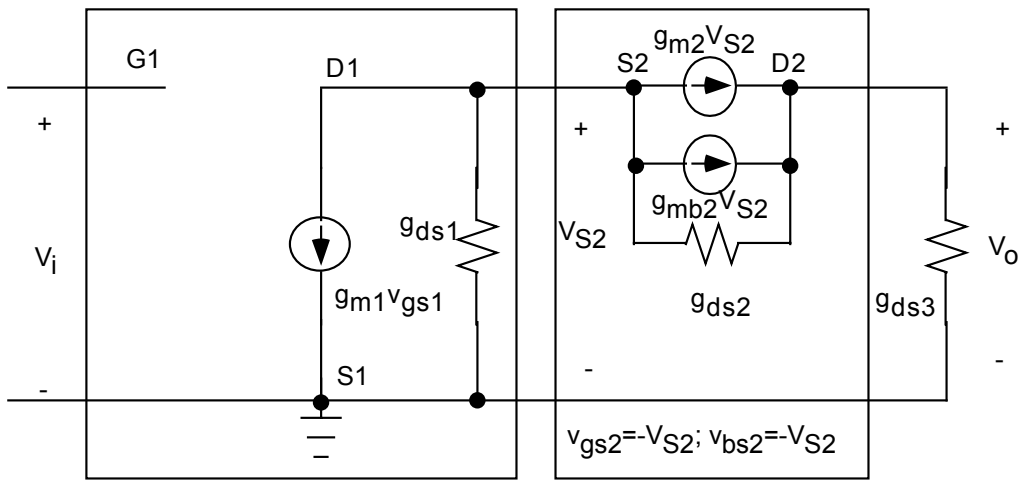
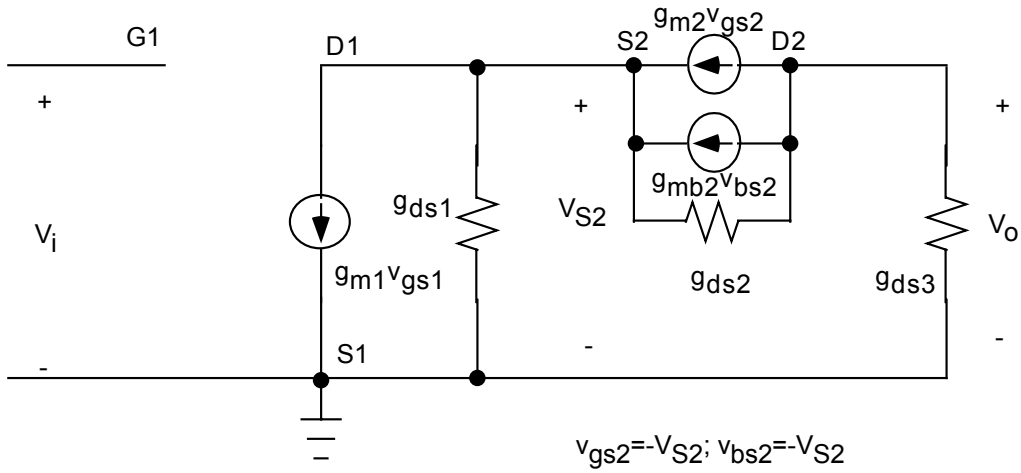

Figure 2. Cascode amplifier low frequency small signal equivalent circuit.

$$Y_L = Y_L^b = g_{ds3} \text{ (or } Z_L^b = r_{ds3}); Y_S = Y_S^a = \infty \text{ (or } Z_S = 0)$$

The current equation of network a is:

$$I_1^a = 0$$

$$I_2^a = g_{m1} V_1^a + g_{ds1} V_2^a$$

The corresponding Y-parameter matrix is:

$$Y^a = \begin{bmatrix} 0 & 0 \\ g_{m1} & g_{ds1} \end{bmatrix}$$

The current equation of network b is:

$$I_1^b = (g_{m2} + g_{mb2} + g_{ds2}) V_1^b - g_{ds2} V_2^b$$

$$I_2^b = -(g_{m2} + g_{mb2} + g_{ds2}) V_1^b + g_{ds2} V_2^b$$

The corresponding Y-parameter matrix is:

$$Y^b = \begin{bmatrix} g_{m2} + g_{mb2} + g_{ds2} & -g_{ds2} \\ -(g_{m2} + g_{mb2} + g_{ds2}) & g_{ds2} \end{bmatrix}$$

The common gate stage gain is:

$$A_V^b = \frac{-y_{21}^b}{y_{22}^b + Y_L^b} = \frac{g_{m2} + g_{mb2} + g_{ds2}}{g_{ds2} + g_{ds3}}$$

The input impedance of common gate stage (the load of common source stage) is:

$$Z_i^b = Z_L^a = \frac{y_{22}^b + Y_L^b}{\det Y^b + y_{11}^b Y_L^b} = \frac{g_{ds2} + g_{ds3}}{(g_{m2} + g_{mb2} + g_{ds2}) g_{ds3}} \approx \frac{2}{g_{m2}}$$

The gain of the common source stage is:

$$A_V^a = \frac{-y_{21}^a}{y_{22}^a + Y_L^a} = \frac{-g_{m1}}{g_{ds1} + \frac{(g_{m2} + g_{mb2} + g_{ds2}) g_{ds3}}{g_{ds2} + g_{ds3}}} = \frac{-g_{m1} (g_{ds2} + g_{ds3})}{g_{ds1} (g_{ds2} + g_{ds3}) + (g_{m2} + g_{mb2} + g_{ds2}) g_{ds3}}$$

$$= \frac{-g_{m1} (g_{ds2} + g_{ds3})}{g_{ds1} g_{ds2} + g_{ds1} g_{ds3} + g_{ds2} g_{ds3} + (g_{m2} + g_{mb2}) g_{ds3}} \approx \frac{-2g_{m1}}{g_{m2} + g_{mb2}} \approx 2$$

Assuming all g_m are equal, and all g_{ds} are equal. In addition $g_m \gg g_{mb}$, and $g_m \gg g_{ds}$.

With a gain of 2 the miller capacitance C_{gd1} of the common source stage is negligible.

The overall gain is:

$$A_V = A_V^b A_V^a = \left(\frac{g_{m2} + g_{mb2} + g_{ds2}}{g_{ds2} + g_{ds3}} \right) \left(\frac{-g_{m1}(g_{ds2} + g_{ds3})}{g_{ds1}g_{ds2} + g_{ds1}g_{ds3} + g_{ds2}g_{ds3} + (g_{m2} + g_{mb2})g_{ds3}} \right)$$

$$= \frac{-g_{m1}(g_{m2} + g_{mb2} + g_{ds2})}{g_{ds1}g_{ds2} + g_{ds1}g_{ds3} + (g_{m2} + g_{mb2} + g_{ds2})g_{ds3}} \approx \frac{-g_m}{g_{ds}}$$

The output impedance of the cascode amplifier is computed by obtaining the output impedance of the common source stage (or the source impedance of the common gate stage) first. That is,

$$Z_o^a = Z_S^b = \frac{y_{11}^a + Y_S^a}{\det Y^a + y_{22}^a Y_S^a} = \frac{1}{y_{22}^a} = \frac{1}{g_{ds1}}$$

The result is obtained by dividing the numerator and denominator by Y_S^a . The output impedance of the cascode is the output impedance of the common gate stage.

$$Z_o^b = \frac{y_{11}^b + Y_S^b}{\det Y^b + y_{22}^b Y_S^b} = \frac{g_{m2} + g_{mb2} + g_{ds2} + g_{ds1}}{g_{ds2}g_{ds1}} = (g_{m2} + g_{mb2})r_{ds2}r_{ds1} + r_{ds1} + r_{ds2} \approx g_{m2}r_{ds2}r_{ds1}$$

That is, the output impedance is equal to the output impedance, r_{ds1} , of the first stage (common source) magnified by the gain, $g_{m2}r_{ds2}$, of the second stage (common gate). The effective load is the parallel combination of output impedance of the cascode amplifier and the load.

$$Z_o = Z_o^b // Z_L = ((g_{m2} + g_{mb2})r_{ds2}r_{ds1} + r_{ds1} + r_{ds2}) // r_{ds3} \approx (g_{m2}r_{ds2}r_{ds1}) // r_{ds3} \approx r_{ds3}$$

The overall gain is approximately equal to :

$$A_V = -g_{m1}Z_o \approx -g_{m1}r_{ds3}$$

Although the output impedance has been magnified but the effective load impedance is determined by smaller impedance. That is, r_{ds3} .

The overall gain of the cascode amplifier can be increased if we can increased r_{ds3} . This can be achieved by adding a cascode at the load. This is shown in Figure 3. Figure 4 shows its low frequency small signal equivalent circuit and its two-port representations and port variables assignment. There are three two-port networks. The Y-parameter matrices are derived as follows:

The current equation of network a is:

$$I_1^a = 0$$

$$I_2^a = g_{m1}V_1^a + g_{ds1}V_2^a$$

The corresponding Y-parameter matrix is:

$$Y^a = \begin{bmatrix} 0 & 0 \\ g_{m1} & g_{ds1} \end{bmatrix}$$

The current equation of network b is:

$$I_1^b = (g_{m2} + g_{mb2} + g_{ds2})V_1^b - g_{ds2}V_2^b$$

$$I_2^b = -(g_{m2} + g_{mb2} + g_{ds2})V_1^b + g_{ds2}V_2^b$$

The corresponding Y-parameter matrix is:

$$Y^b = \begin{bmatrix} g_{m2} + g_{mb2} + g_{ds2} & -g_{ds2} \\ -(g_{m2} + g_{mb2} + g_{ds2}) & g_{ds2} \end{bmatrix}$$

The current equation of network c is:

$$I_1^c = (g_{m3} + g_{mb3} + g_{ds3})V_1^c - g_{ds3}V_2^c$$

$$I_2^c = -(g_{m3} + g_{mb3} + g_{ds3})V_1^c + g_{ds3}V_2^c$$

The corresponding Y-parameter matrix is:

$$Y^c = \begin{bmatrix} g_{m3} + g_{mb3} + g_{ds3} & -g_{ds3} \\ -(g_{m3} + g_{mb3} + g_{ds3}) & g_{ds3} \end{bmatrix}$$

The output impedance of network b has been obtained earlier it is,

$$Z_o^b = (g_{m2} + g_{mb2})r_{ds2}r_{ds1} + r_{ds1} + r_{ds2} \approx g_{m2}r_{ds2}r_{ds1}$$

The output impedance of network c is computed as follows:

$$Z_o^c = \frac{y_{11}^c + Y_S^c}{\det Y^c + y_{22}^c Y_S^c} = \frac{g_{m3} + g_{mb3} + g_{ds3} + g_{ds4}}{g_{ds3}g_{ds4}} = (g_{m3} + g_{mb3})r_{ds3}r_{ds4} + r_{ds3} + r_{ds4} \approx g_{m3}r_{ds3}r_{ds4}$$

The effective load impedance is the parallel combination of the output impedance of network b and c.

$$Z_o = Z_o^b // Z_o^c \approx \frac{g_m r_{ds}^2}{2}$$

Assuming all g_m are equal and all g_{ds} are equal.

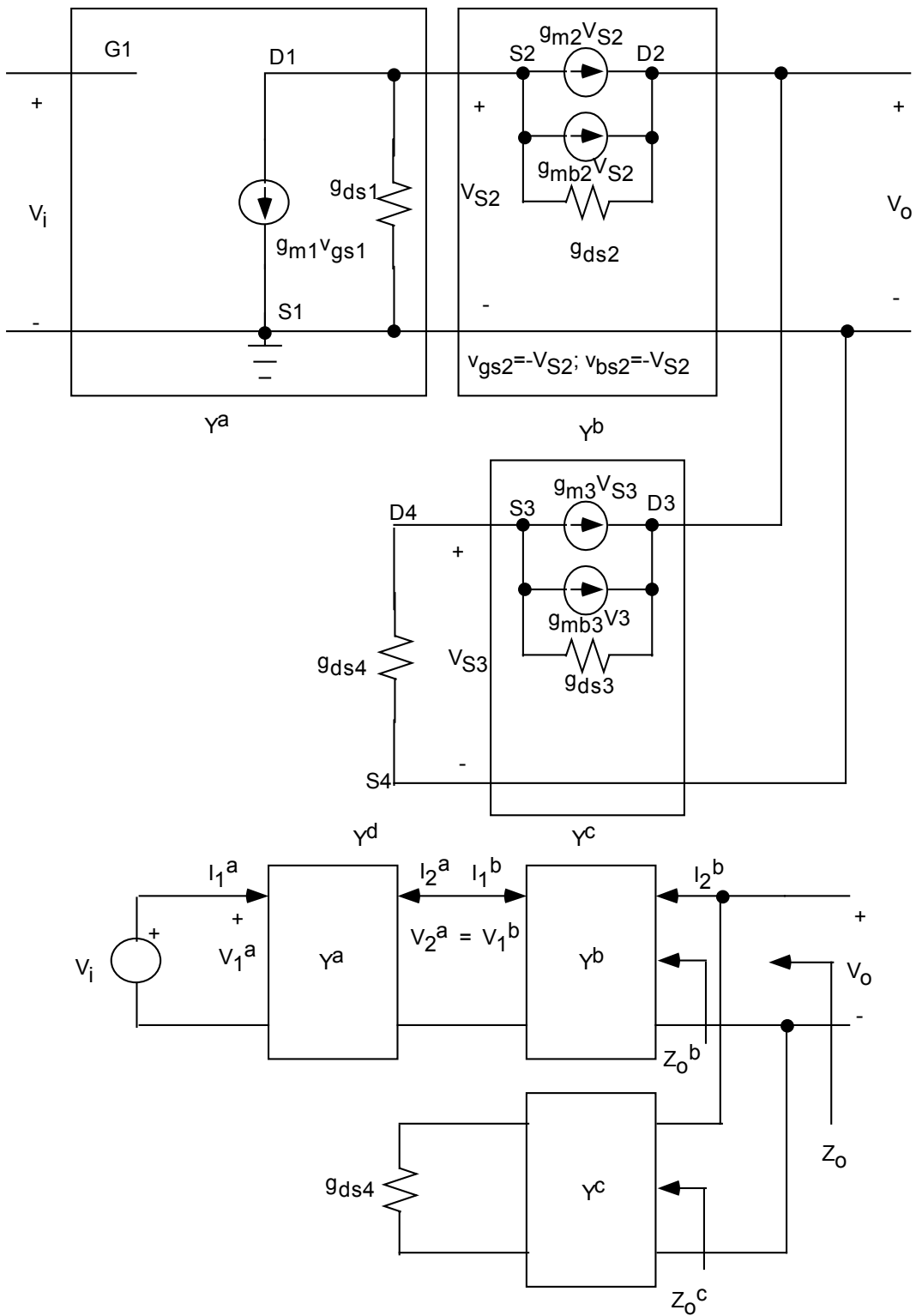

Figure 4. Cascode amplifier with cascode load low frequency small signal equivalent circuit.

2. High Frequency Small Signal Equivalent Circuit

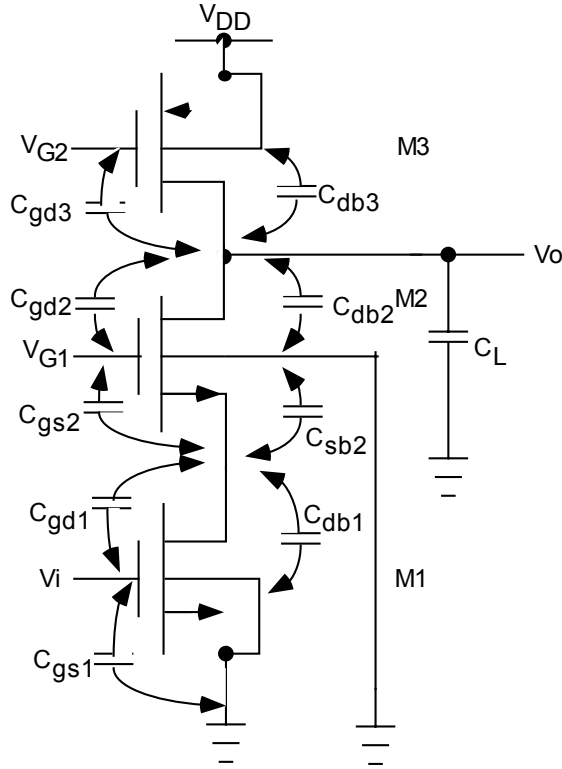

Figure 5. Cascode amplifier parasitic capacitances.

Figure 5 shows all the parasitic capacitances needed for high frequency modelling. Figure 6(a) shows the high frequency small signal equivalent circuit of cascode amplifier with simple current load. Figure 6(b) its two-port representation and port variables assignment.

$$Y_L = Y_L^b = g_{ds3} + sC_3; Y_S = \infty (\text{or } Z_S = 0)$$

$$C_1 = C_{gd1}; C_2 = C_{db1} + C_{gs2} + C_{sb2}; C_3 = C_{gd2} + C_{db2} + C_{db3} + C_{gd3} + C_L$$

The input capacitance C_{gs1} is assumed to be part of the input voltage source. C_{gs1} is shorted out by the input voltage source, it does not affect the circuit operation, hence can be ignored or deleted. C_3 is assumed to be part of the load. The current of the first stage (network a) is given by:

$$I_1^a = sC_1 V_1^a - sC_1 V_2^a$$

$$I_2^a = (g_{m1} - sC_1) V_1^a + [g_{ds1} + s(C_1 + C_2)] V_2^a$$

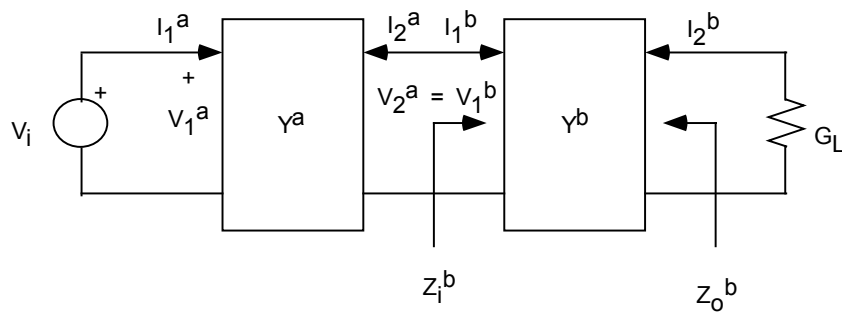
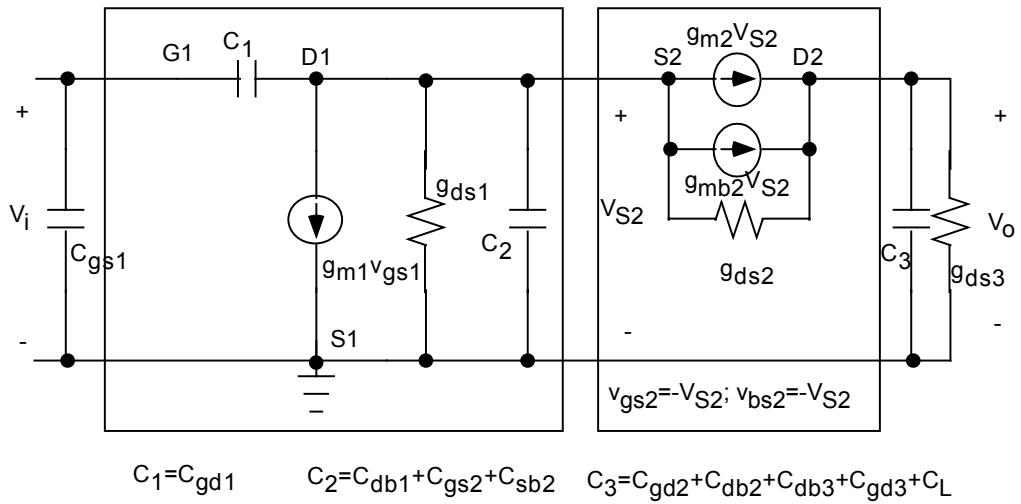

Figure 6. Cascode amplifier high frequency equivalent circuit.

The corresponding Y-parameter matrix is:

$$Y^a = \begin{bmatrix} sC_1 & -sC_1 \\ g_{m1} - sC_1 & [g_{ds1} + s(C_1 + C_2)] \end{bmatrix}$$

The current equation of network b is:

$$I_1^b = (g_{m2} + g_{mb2} + g_{ds2})V_1^a - g_{ds2}V_2^a$$

$$I_2^b = -(g_{m2} + g_{mb2} + g_{ds2})V_1^a + g_{ds2}V_2^a$$

The corresponding Y-parameter matrix is :

$$Y^b = \begin{bmatrix} g_{m2} + g_{mb2} + g_{ds2} & -g_{ds2} \\ -(g_{m2} + g_{mb2} + g_{ds2}) & g_{ds2} \end{bmatrix}$$

The voltage gain of network b is:

$$A_V^b = \frac{-y_{21}^b}{y_{22}^b + Y_L^b} = \frac{g_{m2} + g_{mb2} + g_{ds2}}{g_{ds2} + g_{ds3} + sC_3}$$

The input impedance of network b or load of network a is:

$$Z_i^b = Z_L^a = \frac{y_{22}^b + Y_L^b}{\det Y^b + y_{11}^b Y_L^b} = \frac{g_{ds2} + g_{ds3} + sC_3}{(g_{m2} + g_{mb2} + g_{ds2})(g_{ds3} + sC_3)}$$

The voltage gain of network a is:

$$A_V^a = \frac{-y_{21}^a}{y_{22}^a + Y_L^a} = \frac{-(g_{m1} - sC_1)}{g_{ds1} + s(C_1 + C_2) + \frac{(g_{m2} + g_{mb2} + g_{ds2})(g_{ds3} + sC_3)}{g_{ds2} + g_{ds3} + sC_3}}$$

$$= \frac{-(g_{m1} - sC_1)(g_{ds2} + g_{ds3} + sC_3)}{(g_{ds1} + s(C_1 + C_2))(g_{ds2} + g_{ds3} + sC_3) + (g_{m2} + g_{mb2} + g_{ds2})(g_{ds3} + sC_3)}$$

The overall gain of the cascode amplifier is:

$$\begin{aligned}
A_V &= A_V^b A_V^a \\
&= \left(\frac{g_{m2} + g_{mb2} + g_{ds2}}{g_{ds2} + g_{ds3} + sC_3} \right) \\
&\quad \left(\frac{-(g_{m1} - sC_1)(g_{ds2} + g_{ds3} + sC_3)}{(g_{ds1} + s(C_1 + C_2))(g_{ds2} + g_{ds3} + sC_3) + (g_{m2} + g_{mb2} + g_{ds2})(g_{ds3} + sC_3)} \right) \\
&= \frac{-(g_{m1} - sC_1)(g_{m2} + g_{mb2} + g_{ds2})}{(g_{ds1} + s(C_1 + C_2))(g_{ds2} + g_{ds3} + sC_3) + (g_{m2} + g_{mb2} + g_{ds2})(g_{ds3} + sC_3)} \\
&= \frac{-(g_{m1} - sC_1)(g_{m2} + g_{mb2} + g_{ds2})}{c[1 + bs + as^2]}
\end{aligned}$$

where :

$$\begin{aligned}
a &= \frac{C_3(C_1 + C_2)}{g_{ds1}g_{ds2} + g_{ds3}(g_{m2} + g_{mb2} + g_{ds1} + g_{ds2})} \\
b &= \frac{C_3(g_{ds1} + g_{ds2} + g_{m2} + g_{mb2}) + C_2(g_{ds2} + g_{ds3}) + C_1(g_{ds2} + g_{ds3})}{g_{ds1}g_{ds2} + g_{ds3}(g_{m2} + g_{mb2} + g_{ds1} + g_{ds2})} \\
c &= g_{ds1}g_{ds2} + g_{ds3}(g_{m2} + g_{mb2} + g_{ds1} + g_{ds2})
\end{aligned}$$

If the poles are far apart, it can be approximated as follows:

$$D(s) = 1 + bs + as^2 = \left(1 - \frac{s}{p_1}\right) \left(1 - \frac{s}{p_2}\right) = 1 - \left(\frac{1}{p_1} + \frac{1}{p_2}\right)s + \left(\frac{1}{p_1 p_2}\right)s^2 \approx 1 - \left(\frac{1}{p_1}\right)s + \left(\frac{1}{p_1 p_2}\right)s^2$$

where : $|p_2| \gg |p_1|$

That is,

$$\begin{aligned}
p_1 &= \frac{-1}{b} = \frac{-[g_{ds1}g_{ds2} + g_{ds3}(g_{m2} + g_{mb2} + g_{ds1} + g_{ds2})]}{C_3(g_{ds1} + g_{ds2} + g_{m2} + g_{mb2}) + C_2(g_{ds2} + g_{ds3}) + C_1(g_{ds2} + g_{ds3})} \approx \frac{-g_{ds3}}{C_3} \\
p_2 &= \frac{-b}{a} = \frac{-[C_3(g_{ds1} + g_{ds2} + g_{m2} + g_{mb2}) + C_2(g_{ds2} + g_{ds3}) + C_1(g_{ds2} + g_{ds3})]}{C_3(C_1 + C_2)} \approx \frac{-g_{m2}}{C_1 + C_2}
\end{aligned}$$

Note that the poles are associated with the inverse product of the resistance and capacitance of a node to ground. p_1 is associated with node D2 to ground, and p_2 is associated with D1 (or S2) to ground. The cascode amplifier also has a zero at the right half plane given by:

$$z_1 = \frac{g_{m1}}{C_1}$$

Cascode Amplifier Experiments

3. Cascode Amplifier with Simple Current Load

The biasing voltages will be determined by ignoring the effect of the bulk voltage on M2. Using the biasing principle discussed in the current sink/source section. The biasing requirement from Figure 1(b) are:

$$V_{\text{bias}} = V_{\text{TN0}} + \Delta V = 1 + 1.5 = 2.5$$

$$V_{\text{G2}} = 2V_{\text{TN}} + 2\Delta V = 2(1) + 2(1.5) = 5$$

$$V_{\text{G3}} = V_{\text{DD}} - (|V_{\text{TP0}}| + |\Delta V|) = V_{\text{DD}} - (|-1| + |1.5|) = V_{\text{DD}} - 2.5$$

The output voltage dynamic range with the above biasing is:

$$V_{\text{TN}} + 2\Delta V \leq V_{\text{O}} \leq V_{\text{DD}} - \Delta V$$

$$1 + 2(1.5) = 4 \leq V_{\text{O}} \leq V_{\text{DD}} - 1.5$$

$$4 \leq V_{\text{O}} \leq 6; \text{ If } V_{\text{DD}} = 7.5$$

$$V_{\text{G3}} = V_{\text{DD}} - 2.5 = 7.5 - 2.5 = 5$$

The effect of bulk bias on M2 on the output voltage will be considered next. The actual minimum output voltage will be determined. The threshold voltage of M2 is no longer equal to V_{T0} , due to the present of the bulk bias.

$$V_{\text{BS2}} = -V_{\text{DS1}}$$

$$V_{\text{TN2}} = V_{\text{TN0}} + \gamma(\sqrt{\phi - V_{\text{BS2}}} - \sqrt{\phi}) = V_{\text{TN0}} + \gamma(\sqrt{\phi + V_{\text{DS1}}} - \sqrt{\phi})$$

$$V_{\text{DS1}} = V_{\text{G2}} - V_{\text{TN2}} - \Delta V$$

$$V_{\text{TN2}} = V_{\text{T0}} + \gamma(\sqrt{\phi + V_{\text{G2}} - V_{\text{TN2}} - \Delta V} - \sqrt{\phi})$$

Solve for V_{TN2} by iteration

$$V_{\text{TN2}} = 1.75$$

$$V_{\text{DS1}(\text{min})} = V_{\text{G2}} - V_{\text{TN2}} - \Delta V = 5 - 1.75 - 1.5 = 1.75$$

$$V_{\text{DS2}(\text{min})} = \Delta V = 1.5$$

$$V_{\text{O}(\text{min})} = V_{\text{DS1}(\text{min})} + V_{\text{DS2}(\text{min})} = 1.75 + 1.5 = 3.25$$

$$3.325 \leq V_{\text{O}} \leq 6$$

The bulk bias increases the output voltage dynamic range. Using the above biasing voltages, Pspice simulation is conducted to obtain the DC transfer characteristic curve. The Pspice netlist below is used to obtain the DC transfer characteristic.

```

*Pspice file for NMOS Common Gate Amplifier with
*PMOS Current Load
*Filename="Lab3.cir"
VIN 1 0 DC 2.5212VOLT AC 1V
VDD 3 0 DC 7.5VOLT
VSS 4 0 DC 0VOLT
VG2 6 0 DC 5VOLT
VG3 7 0 DC 5VOLT
M1 5 1 4 4 MN W=9.6U L=5.4U
M2 2 6 5 4 MN W=9.6U L=5.4U
M3 2 7 3 3 MP W=25.8U L=5.4U

.MODEL MN NMOS VTO=1 KP=40U
+ GAMMA=1.0 LAMBDA=0.02 PHI=0.6
+ TOX=0.05U LD=0.5U CJ=5E-4 CJSW=10E-10
+ U0=550 MJ=0.5 MJSW=0.5 CGSO=0.4E-9 CGDO=0.4E-9
.MODEL MP PMOS VTO=-1 KP=15U
+ GAMMA=0.6 LAMBDA=0.02 PHI=0.6
+ TOX=0.05U LD=0.5U CJ=5E-4 CJSW=10E-10
+ U0=200 MJ=0.5 MJSW=0.5 CGSO=0.4E-9 CGDO=0.4E-9
*Analysis
.DC VIN 0 7.5 0.05
.TF V(2) VIN
.AC DEC 100 1HZ 10GHZ
.PROBE
.END

```

The exact V_{bias} is determined by locating a point in the DC transfer characteristic curve with the highest slope. The AC small signal characteristic and operating node voltages are then obtained at this operating point. The Pspice node voltages at the operating point is given below:

NODE VOLTAGE NODE VOLTAGE NODE VOLTAGE NODE VOLTAGE

(1) 2.5212 (2) 4.6987 (3) 7.5000 (4) 0.0000

(5) 1.7410 (6) 5.0000 (7) 5.0000

The voltage at node 5 is 1.7410 which is reasonably closed to the calculated value of $V_{\text{DS1}(\text{min})}=1.75$. If we ignore the bulk bias of M2 the calculated value is :

$$V_{\text{DS1}(\text{min})} = V_{\text{TN0}} + \Delta V = 1 + 1.5 = 2.5$$

The DC transfer characteristic curve is given below:

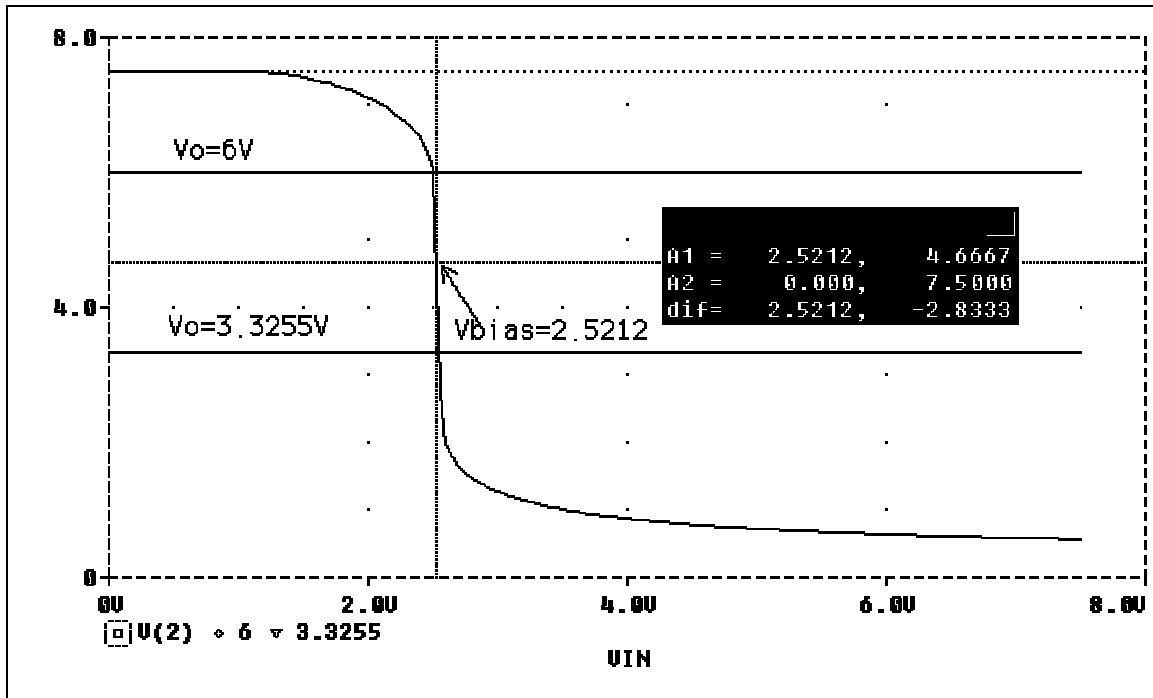

Theoretical calculations of the small signal parameters are given below:

$$\beta_{N1} = K_N (W/L)_1 = (40E - 6)(9.6u/4.4u) = 87.3uA/V^2$$

$$I_{DSQ} = (\beta_{N1} / 2)(V_{bias} - V_{SS} - V_{T0})^2 = (87.3E - 6/2)(2.5212 - 0 - 1)^2 = 101uA$$

$$R_{out} = r_{ds3} = \frac{1}{\lambda I_{DSQ}} = \frac{1}{(.02)(101E - 6)} = .495M$$

$$g_{m1} = g_{m2} = \sqrt{2\beta_{N1} I_{DSQ}} = \sqrt{2(87.3E - 6)(101E - 6)} = 132.79u\text{mho}$$

$$A_{V0} = -g_{m1} R_{out} = -(132.79E - 6)(.495E6) = -65.75 \text{ or } 36.355\text{db}$$

The Pspice results are:

$$R_{out} = .5M$$

$$A_{V0} = -67.95 \text{ or } 36.644\text{db}$$

**** SMALL-SIGNAL CHARACTERISTICS

$$V(2)/V_{IN} = -6.795E+01$$

$$\text{INPUT RESISTANCE AT } V_{IN} = 1.000E+20$$

$$\text{OUTPUT RESISTANCE AT } V(2) = 5.000E+05$$

4. Cascode Amplifier High Frequency Model Experiments

The parasitic capacitances will be determined to check the theory against Pspice simulation results. The capacitances are determined at the operating point. The reverse bulk bias are first calculated at the quiescent operating point.

For M1

$$V_{BD}=V(4)-V(5)=0-1.7410=-1.7410$$

$V_{BS}=0$, bulk connected to source

For M2

$$V_{BD}=V(4)-V(2)=0-4.6987=-4.6967$$

$$V_{BS}=V(4)-V(5)=0-1.7410=-1.7410$$

For M3

$$V_{BD}=- (V(3)-V(2))=-(7.5-4.6987)=-2.8013$$

The MATLAB program is invoked to obtain the parasitic capacitances.

For M1,

$$[C_{GS},C_{GD},C_{BD},C_{BS}]=\text{cap}(9.6,5.4,-1.7410,0)$$

$$C_{GS}=23.2704\text{fF}, C_{GD}=3.84\text{fF}, C_{BD}=24.1791\text{fF}, C_{BS}=61.84\text{fF}$$

For M2,

$$[C_{GS},C_{GD},C_{BD},C_{BS}]=\text{cap}(9.6,5.4,-4.6987,-1.7410)$$

$$C_{GS}=23.2704\text{fF}, C_{GD}=3.84\text{fF}, C_{BD}=16.0715\text{fF}, C_{BS}=38.2591\text{fF}$$

For M3,

$$[C_{GS},C_{GD},C_{BD},C_{BS}]=\text{cap}(25.8,5.4,-2.8013,0)$$

$$C_{GS}=62.5392\text{fF}, C_{GD}=10.32\text{fF}, C_{BD}=47.956\text{fF}, C_{BS}=152.02\text{fF}$$

In the simulation without specifying the area and perimeter of source and drain, only C_{gs} and C_{gd} are accounted in computing the parasitic capacitances. These are calculated below:

$$C1=C_{gd1}=3.84\text{fF}$$

$$C2=C_{gs2}=23.2704\text{fF}$$

$$C3=C_{gd2}+C_{gd3}+C_L=3.84\text{fF}+10.32\text{fF}+0=14.16\text{fF}$$

$$w_{BW} = p_1 = \frac{1}{r_{ds3} C_3} = \frac{1}{(0.495E6)(14.16E-15)} = 142.67E6$$

$$f_{BW} = \frac{w_{BW}}{2\pi} = \frac{142.67E6}{2\pi} = 22.7M$$

$$w_{GBW} = A_{v0} w_{BW} = (65.75)(142.67E6) = 9.38E9$$

$$f_{GBW} = \frac{w_{GBW}}{2\pi} = \frac{9.38E9}{2\pi} = 1.493G$$

$$p_2 = \frac{-g_{m2}}{C_1 + C_2} = \frac{-132.79E-6}{(3.84 + 23.2704)E-15} = 4.898E9$$

$$f_{p2} = \frac{p_2}{2\pi} = \frac{4.898E9}{2\pi} = .7799G$$

$$z = \frac{g_{m1}}{C_1} = \frac{132.79E-6}{3.84E-15} = 34.1E9$$

$$f_z = \frac{z}{2\pi} = \frac{34.1E9}{2\pi} = 5.43G$$

$$\begin{aligned} PM &= 90 - \tan^{-1}\left(\frac{w_{GBW}}{z}\right) - \tan^{-1}\left(\frac{w_{GBW}}{p_2}\right) \\ &= 90 - \tan^{-1}\left(\frac{9.38E9}{34.1E9}\right) - \tan^{-1}\left(\frac{9.38E9}{4.898E9}\right) = 90 - 15.38 - 62.43 = 12.19 \end{aligned}$$

In the Pspice simulation, if the PM is determined at the frequency where zero db gain occurs the result is:

$$f_{GBW} = 1G @0db$$

$$PM = 33.84$$

This result seem to be quite different from the theoretical result of

$$f_{GBW} = 1.493G$$

$$PM = 12.19$$

The discrepancy occurs because the non-dominant pole $p_2=4.898E9$ occurs before the gain bandwidth product $w_{GBW}=9.38E9$. The gain bandwidth calculation assume that the slope of -20db/dec is maintain before intersecting the zero db line. With p_2 occurring before w_{GBW} means that the slope becomes -40db/dec, causing it to intersect the zero db gain line sooner. If one extend the -20db/dec line in the Pspice simulation, this line will intersect the zero db gain axis at:

$$f_{GBW} = A_{v0} f_{BW} = (67.95)(22.496M) = 1.53G$$

If the phase margin is determined at 1.53G, the result is 16.744° which is closer to the theretical calculation of 12.19°. That is, the

theretical calculation will be in error if the non-dominant pole p_2 occurs before ω_{GBW} .

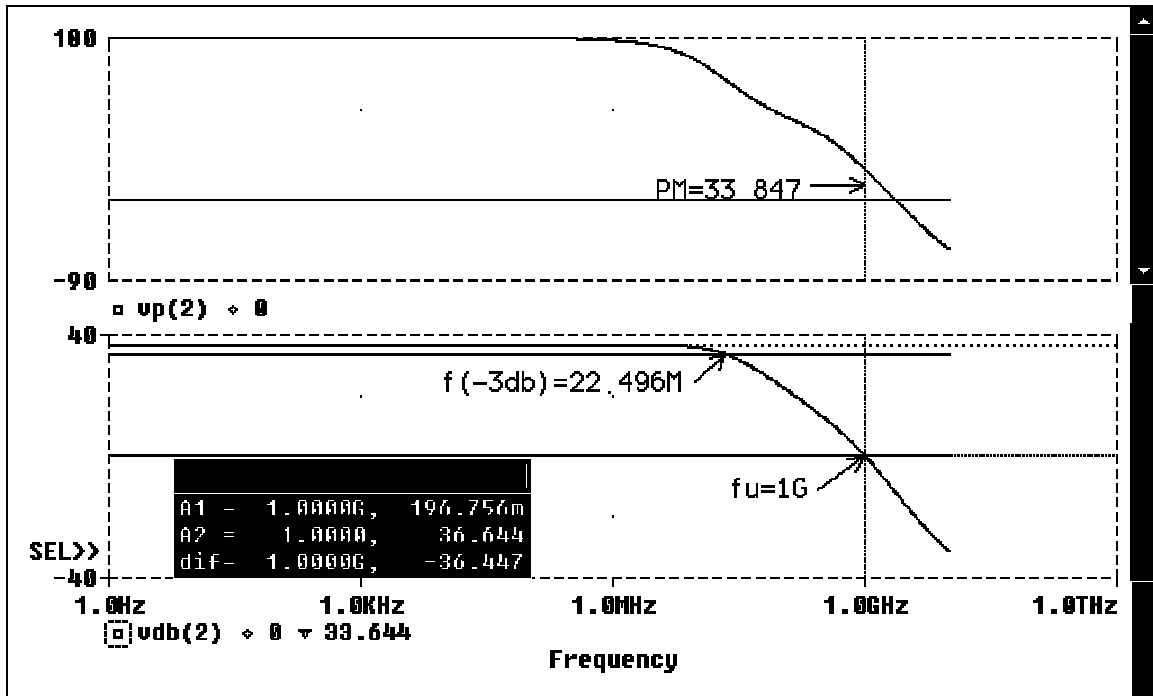

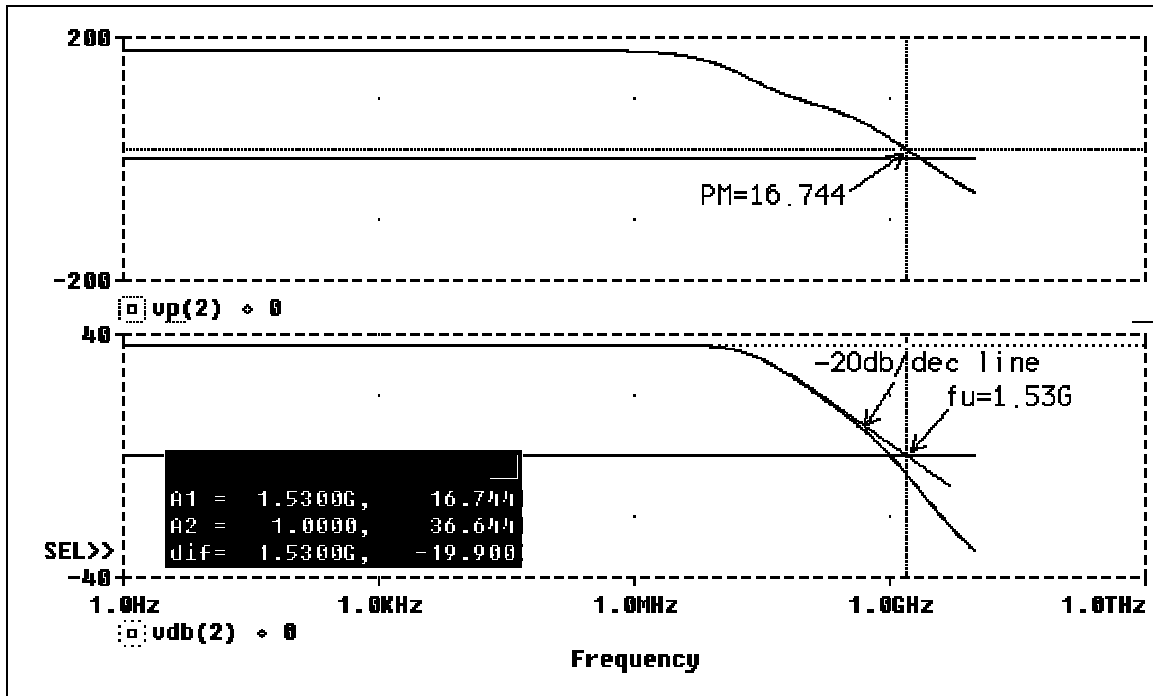

The PM of 33.84 is rather low. For stability a PM of at least 60 is desirable. Looking at the PM calculation, one can increase the PM by decreasing w_{GBW} . Increasing the value of capacitor C_3 will decrease w_{GBW} while maintaining the value of p_2 . C_3 is a function of the load capacitance C_L . One can compute the value of C_L needed to achieve the desired PM. To illustrate this we will compute the value of C_L for a PM=80.

First compute w_{GBW} to achieve PM=80.

$$PM = 90 - \tan^{-1}\left(\frac{w_{GBW}}{z}\right) - \tan^{-1}\left(\frac{w_{GBW}}{p_2}\right) = 80$$

$$\tan^{-1}\left(\frac{w_{GBW}}{z}\right) + \tan^{-1}\left(\frac{w_{GBW}}{p_2}\right) = 10$$

$$\tan^{-1}\left(\frac{w_{GBW}}{34.1E9}\right) + \tan^{-1}\left(\frac{w_{GBW}}{4.898E9}\right) = 10$$

$$w_{GBW} = 0.75G$$

The value of load capacitance is then calculated to achieve w_{GBW} .

$$W_{GBW} = A_{v0} \left(\frac{1}{r_{ds3} C_3} \right)$$

$$C_3 = \frac{A_{v0}}{r_{ds3} W_{GBW}} = 14.16 \text{fF} + C_L$$

$$C_L = \frac{A_{v0}}{r_{ds3} W_{GBW}} - 14.16 \text{fF} = \frac{67.95}{(.495\text{E}6)(0.75\text{E}9)} - 14.16 \text{fF} = 183.03 \text{fF} - 14.16 \text{fF} = 168.87 \text{fF}$$

The result of Pspice simulation with C_L added shows that PM is now 82.195° .

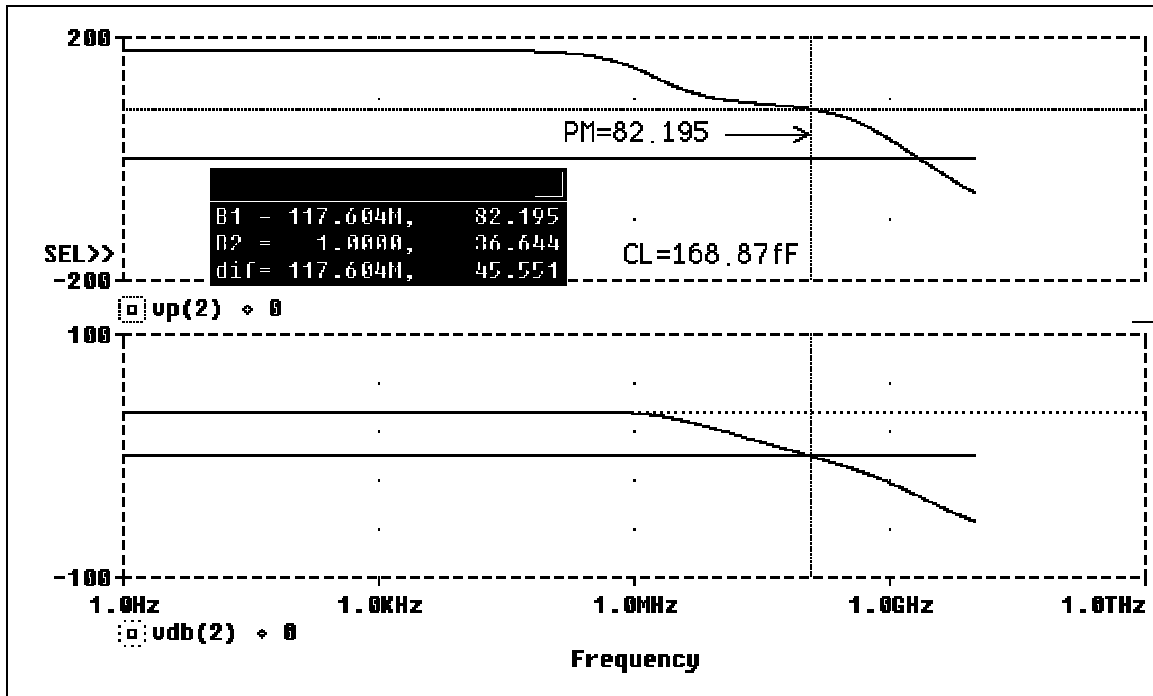

Filename="cascexp3.doc"

5. Cascode Amplifier With Cascode Current Load Experiments

The derivation of the biasing circuit is shown in Figure 7. The complete circuit is shown in Figure 8.

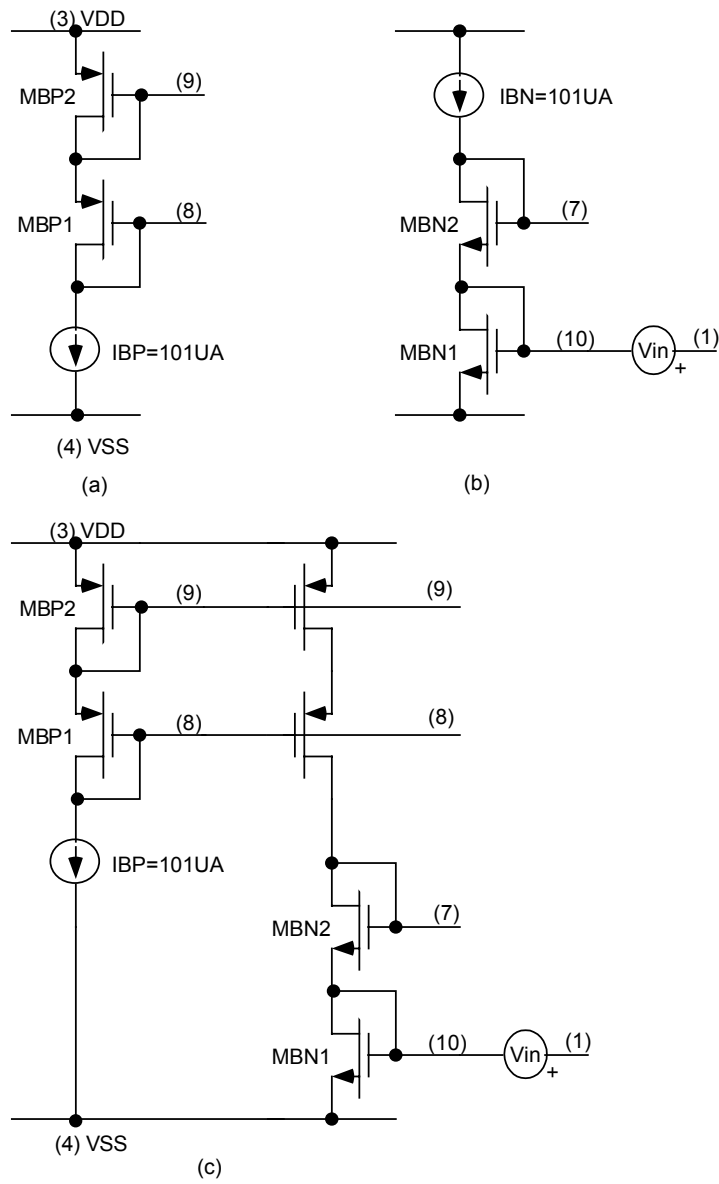

Figure 7. Biasing circuit for the cascode amplifier with cascode load.

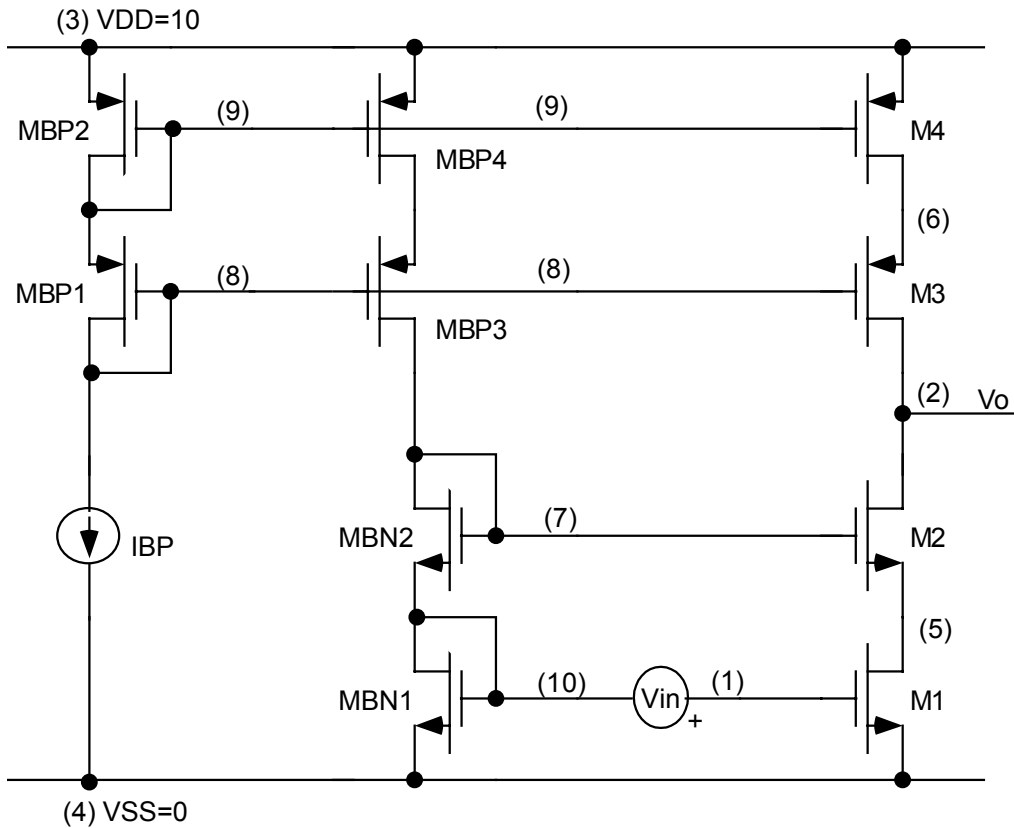

Figure 8. Complete circuit of the cascode amplifier with cascode load.

Netlist for the complete circuit of Figure 8 is shown below:

```

*PSpice file for NMOS Common Gate Amplifier with
*PMOS Current Load
*Filename="Lab32b.cir"
*All bulks are connected to supply rail
.PARAM Wn=9.6U, Ln=5.4U
.PARAM Wp=25.8U, Lp=5.4U
VIN 1 10 DC 0VOLT AC 1V
VDD 3 0 DC 10VOLT
VSS 4 0 DC 0VOLT

M1 5 1 4 4 NMOS1 W={Wn} L={Ln}
M2 2 7 5 4 NMOS1 W={Wn} L={Ln}
M3 2 8 6 3 PMOS1 W={Wp} L={Lp}
M4 6 9 3 3 PMOS1 W={Wp} L={Lp}

*Biasing circuit
MBN1 10 10 4 4 NMOS1 W={Wn} L={Ln}
MBN2 7 7 10 4 NMOS1 W={Wn} L={Ln}
IBP 8 4 100UA
MBP1 8 8 9 3 PMOS1 W={Wp} L={Lp}
MBP2 9 9 3 3 PMOS1 W={Wp} L={Lp}
MBP3 7 8 11 3 PMOS1 W={Wp} L={Lp}
MBP4 11 9 3 3 PMOS1 W={Wp} L={Lp}

```

```
.MODEL NMOS1 NMOS VTO=1 KP=40U
+ GAMMA=1.0 LAMBDA=0.02 PHI=0.6
+ TOX=0.05U LD=0.5U CJ=5E-4 CJSW=10E-10
+ U0=550 MJ=0.5 MJSW=0.5 CGSO=0.4E-9 CGDO=0.4E-9
.MODEL PMOS1 PMOS VTO=-1 KP=15U
+ GAMMA=0.6 LAMBDA=0.02 PHI=0.6
+ TOX=0.05U LD=0.5U CJ=5E-4 CJSW=10E-10
+ U0=200 MJ=0.5 MJSW=0.5 CGSO=0.4E-9 CGDO=0.4E-9
```

```
*Analysis
.DC VIN -2.5 7.5 0.05
.TF V(2) VIN
.AC DEC 100 1HZ 10GHZ
.PROBE
.END
```

NODE VOLTAGE NODE VOLTAGE NODE VOLTAGE NODE VOLTAGE

```
( 1) 2.4774 ( 2) 5.9211 ( 3) 10.0000 ( 4) 0.0000
( 5) 2.4774 ( 6) 7.5450 ( 7) 5.9211 ( 8) 4.4772
( 9) 7.5280 (10) 2.4774 (11) 7.5450
```

The biasing voltages are obtained from the above table

```
VG1=Vbias=V(10)=2.4774
VG2=V(7)=5.9211
VG3=V(8)=4.4772
VG4=V(9)=7.5280
```

The low frequency small signal parameters are:

$$\beta_{N1} = K_N (W/L)_1 = (40E-6)(9.6u/4.4u) = 87.3uA/V^2$$

$$I_{DSQ} = 100uA = I_{BIAS}$$

$$r_{ds1} = r_{ds2} = \frac{1}{\lambda I_{DSQ}} = \frac{1}{(.02)(100E-6)} = .5M$$

$$g_{m1} = g_{m2} = \sqrt{2\beta_{N1} I_{DSQ}} = \sqrt{2(87.3E-6)(100E-6)} = 132.13\mu mho$$

$$R_{out} = \frac{g_{m2} r_{ds2} r_{ds1}}{2} = \frac{(132.13E-6)(0.5E6)(0.5E6)}{2} = 16.52M$$

$$A_{V0} = g_{m1} R_{out} = (132.13E-6)(16.52E6) = 2182.78$$

Pspice simulation results:
 **** SMALL-SIGNAL CHARACTERISTICS

V(2)/VIN = -3.136E+03

INPUT RESISTANCE AT VIN = -2.424E+19

OUTPUT RESISTANCE AT V(2) = 2.342E+07

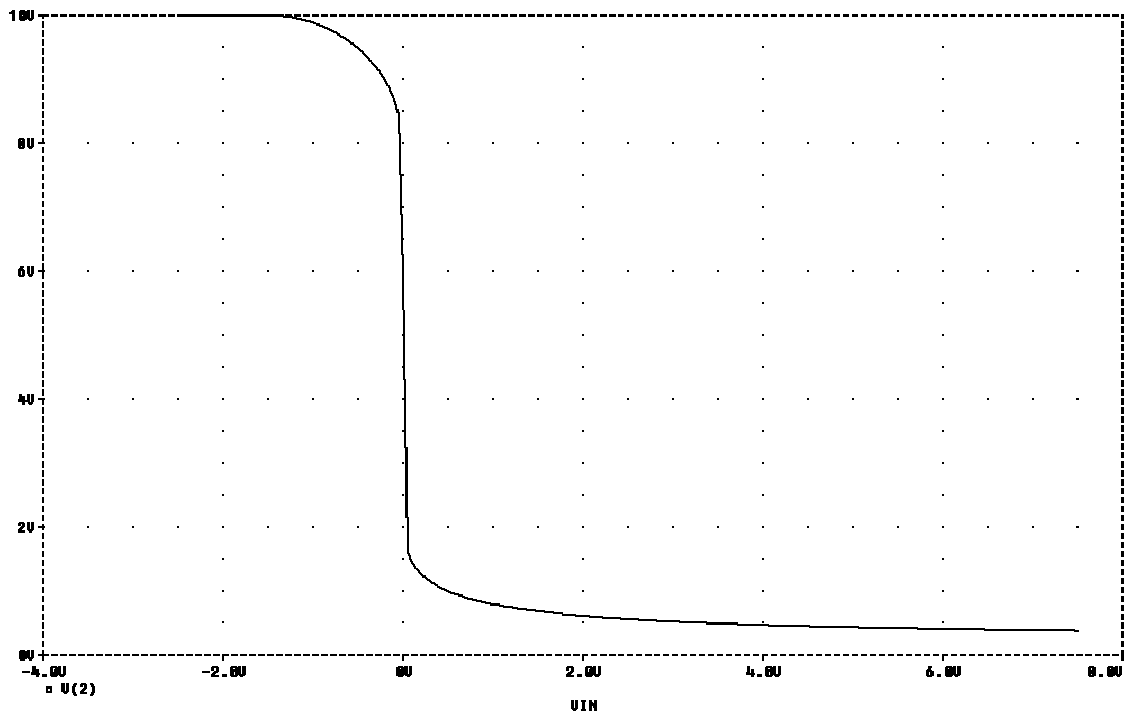

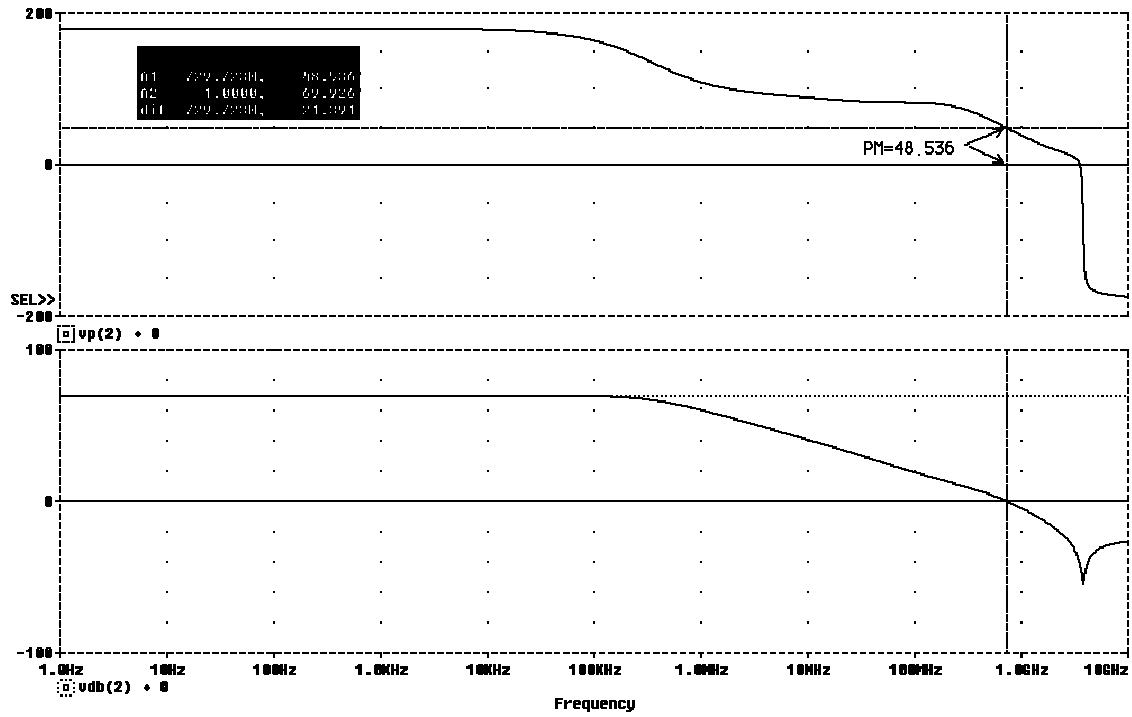

6. Cascode Amplifier Design Example

Design specification

Given: $A_V \geq 10,000$ $R_o \geq 10\text{Meg}$

Find: V_{DD} , acceptable output voltage swing, and transistor sizing

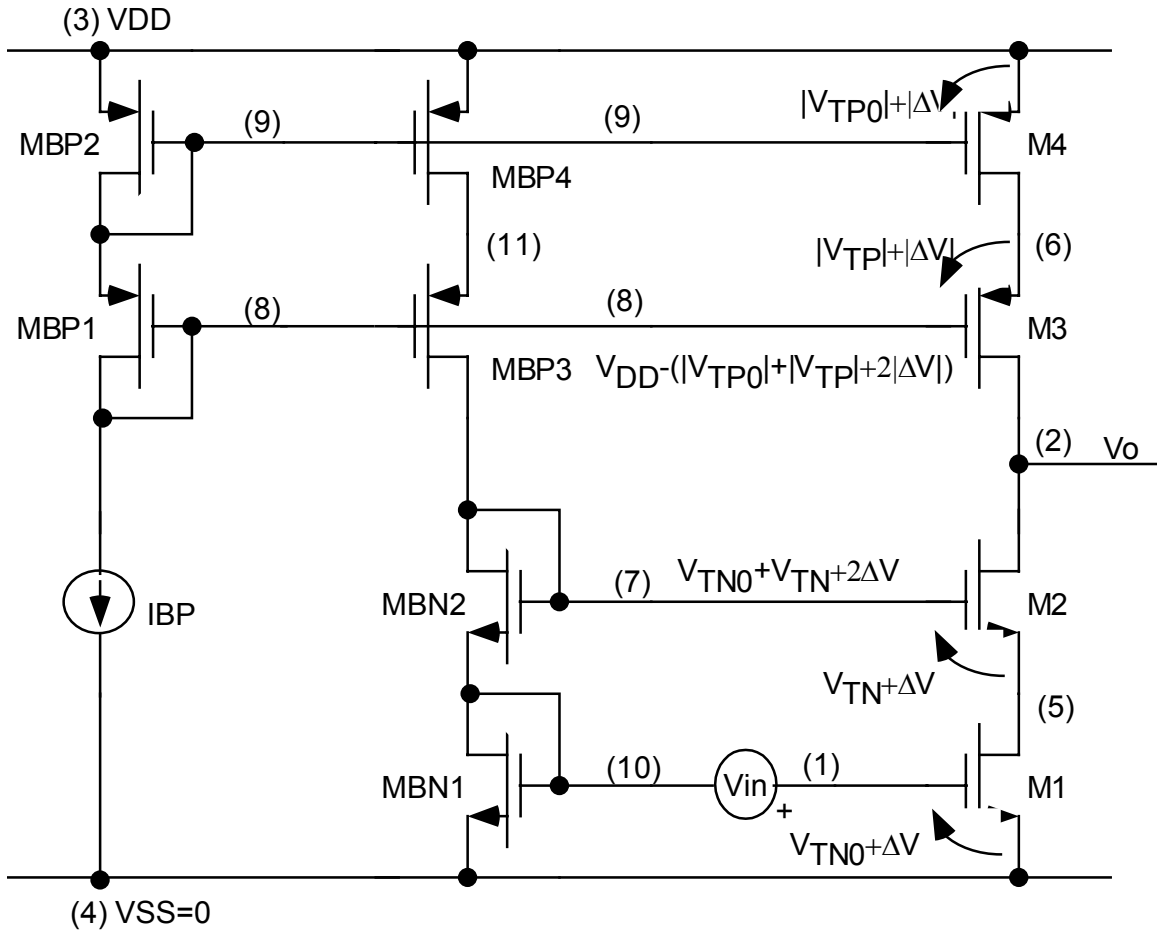

Design Procedure

$$A_V = -g_{m1} R_O$$

$$g_{m1} = -\frac{A_V}{R_O} = -\frac{10000}{10\text{M}} = -1000\mu\text{mho}$$

$$R_O = R_{ON} // R_{OP}$$

$$R_{ON} = R_{OP} = 2R_O$$

$$R_{ON} \approx g_{m2} r_{O2} r_{O1} = g_{m1} r_{O1}^2 = 2R_O \quad ; r_{O1} = r_{O2}$$

$$r_{O1} = \sqrt{\frac{2R_O}{g_{m1}}} = \sqrt{\frac{2R_O^2}{A_V}} = R_O \sqrt{\frac{2}{A_V}} = (10\text{M}) \sqrt{\frac{2}{10000}} = 0.141\text{M}$$

$$r_{O1} = \frac{1}{\lambda I_{DSQ}}$$

$$I_{DSQ} = \frac{1}{\lambda r_{O1}} = \frac{1}{(0.02)(0.141M)} = 354\mu A$$

$$g_{m1} = \sqrt{2\beta_N I_{DSQ}} = \sqrt{2K_N (W/L)_1 I_{DSQ}}$$

$$(W/L)_1 = (W/L)_2 = \frac{g_{m1}^2}{2K_N I_{DSQ}} = \frac{(1000E-6)^2}{2(40E-6)(354E-6)} = 35.3$$

$$I_{DSQ} = (\beta/2)(V_{GS} - V_T)^2 = (\beta/2)(\Delta V)^2$$

$$\Delta V = \sqrt{\frac{2I_{DSQ}}{\beta}} = \sqrt{\frac{2I_{DSQ}}{K_N (W/L)_1}} = \sqrt{\frac{2(354E-6)}{(40E-6)(35.3)}} = 0.708$$

Output voltage swing neglecting bulk to source effect

$$V_{TON} + 2\Delta V \leq V_O \leq V_{DD} - (|V_{TOP}| + 2|\Delta V|)$$

$$1 + 2(0.708) = 2.416 \leq V_O \leq V_{DD} - (1 + 2(.708)) = V_{DD} - 2.416$$

$$2.416 \leq V_{DD} \leq 2.584 \quad ; V_{DD} = 5V \quad (\text{not acceptable})$$

$$2.416 \leq V_{DD} \leq 5.084 \quad ; V_{DD} = 7.5V \quad (\text{acceptable})$$

Designing for equal ΔV or $\beta_R=1$

$$(W/L)_3 = (W/L)_3 = \frac{K_N}{K_P} (W/L)_1 = \frac{40E-6}{15E-5} (35.3) = 94.13$$

$$\frac{W_1}{L_1} = \frac{W_2}{L_2} = \frac{W_N}{L_{Neff}} = 35.3 \left(\frac{3}{3} \right) = \frac{105.9L}{3L}$$

$$\frac{W_3}{L_3} = \frac{W_3}{L_3} = \frac{W_P}{L_{Peff}} = 94.13 \left(\frac{3}{3} \right) = \frac{282L}{3L}$$

For Lambda L=0.6

$$W_N = 105.9L = 105.9(0.6U) = 63.54U \approx 63.6U$$

$$L_N = L_{Neff} + 2LD = 3L + 2LD = 3(0.6U) + 2(0.5U) = 2.8U \approx 3U$$

$$W_P = 282L = 282(0.6U) = 169.2U$$

$$L_P = L_N = 3U$$

*PSpice file for NMOS Common Gate Amplifier with

*PMOS Current Load

*Filename="Lab61.cir"

*All bulks are connected to supply rail

.PARAM Wn=63.6U, Ln=3U

.PARAM Wp=169.2U, Lp=3U

VIN 1 10 DC 0VOLT AC 1V

VDD 3 0 DC 7.5VOLT

VSS 4 0 DC 0VOLT

M1 5 1 4 4 NMOS1 W={Wn} L={Ln}

M2 2 7 5 4 NMOS1 W={Wn} L={Ln}

M3 2 8 6 3 PMOS1 W={Wp} L={Lp}

M4 6 9 3 3 PMOS1 W={Wp} L={Lp}

*Biasing circuit

MBN1 10 10 4 4 NMOS1 W={Wn} L={Ln}

MBN2 7 7 10 4 NMOS1 W={Wn} L={Ln}

IBP 8 4 354UA

MBP1 8 8 9 3 PMOS1 W={Wp} L={Lp}

MBP2 9 9 3 3 PMOS1 W={Wp} L={Lp}

MBP3 7 8 11 3 PMOS1 W={Wp} L={Lp}

MBP4 11 9 3 3 PMOS1 W={Wp} L={Lp}

.MODEL NMOS1 NMOS VTO=1 KP=40U

+ GAMMA=1.0 LAMBDA=0.02 PHI=0.6

+ TOX=0.05U LD=0.5U CJ=5E-4 CJSW=10E-10

+ U0=550 MJ=0.5 MJSW=0.5 CGSO=0.4E-9 CGDO=0.4E-9

.MODEL PMOS1 PMOS VTO=-1 KP=15U

+ GAMMA=0.6 LAMBDA=0.02 PHI=0.6

+ TOX=0.05U LD=0.5U CJ=5E-4 CJSW=10E-10

+ U0=200 MJ=0.5 MJSW=0.5 CGSO=0.4E-9 CGDO=0.4E-9

*Analysis

.DC VIN -2.5 7.5 0.05

.TF V(2) VIN

.AC DEC 100 1HZ 10GHZ

.PROBE

.END

**** SMALL-SIGNAL CHARACTERISTICS

V(2)/VIN = -1.268E+04

INPUT RESISTANCE AT VIN = -1.318E+19

OUTPUT RESISTANCE AT V(2) = 1.321E+07

NODE VOLTAGE NODE VOLTAGE NODE VOLTAGE NODE VOLTAGE

(1) 1.7334 (2) 4.2146 (3) 7.5000 (4) 0.0000

(5) 1.7334 (6) 5.7694 (7) 4.2146 (8) 3.5826

(9) 5.7657 (10) 1.7334 (11) 5.7694

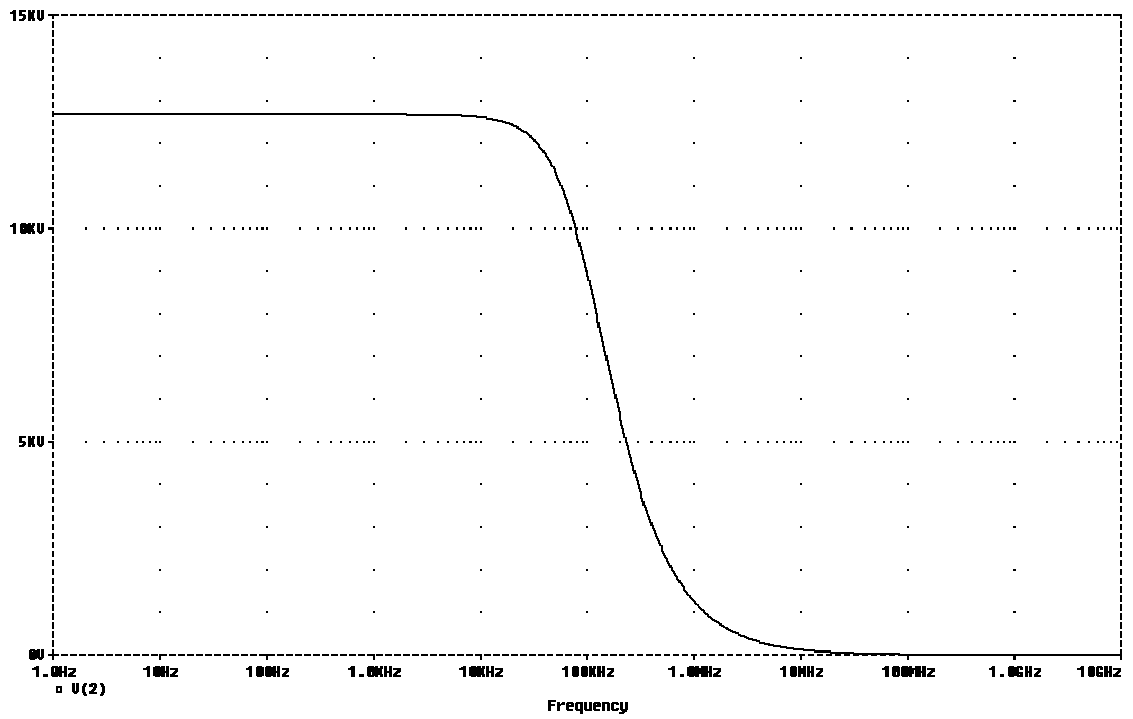
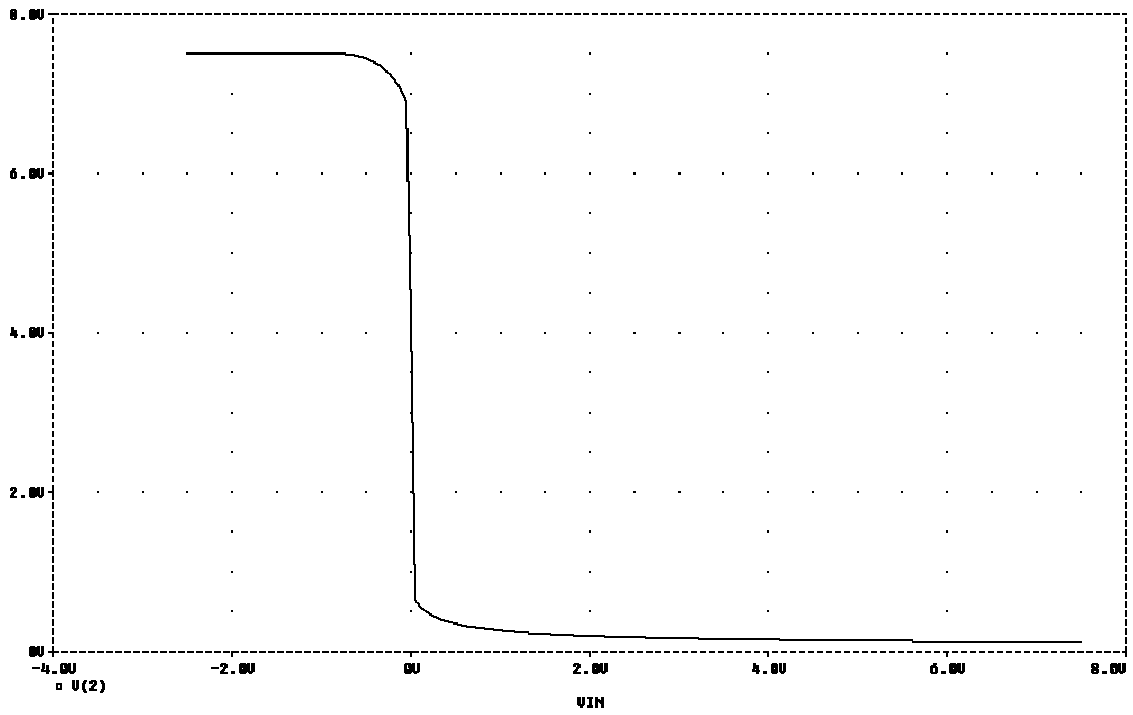

The circuit is simulated with VDD=5V to show that the resulting cascode does not yield the desired gain and output impedance. Replace the VDD line in the netlist to:

VDD 3 0 DC 5VOLT

**** SMALL-SIGNAL CHARACTERISTICS

V(2)/VIN = -1.216E+01

INPUT RESISTANCE AT VIN = 3.651E+18

OUTPUT RESISTANCE AT V(2) = 1.285E+04

NODE VOLTAGE NODE VOLTAGE NODE VOLTAGE NODE VOLTAGE

(1) 1.7233 (2) 4.1910 (3) 5.0000 (4) 0.0000

(5) 1.7233 (6) 4.3287 (7) 4.1910 (8) 1.0826

(9) 3.2657 (10) 1.7233 (11) 4.3287