

CMOS Fabrication

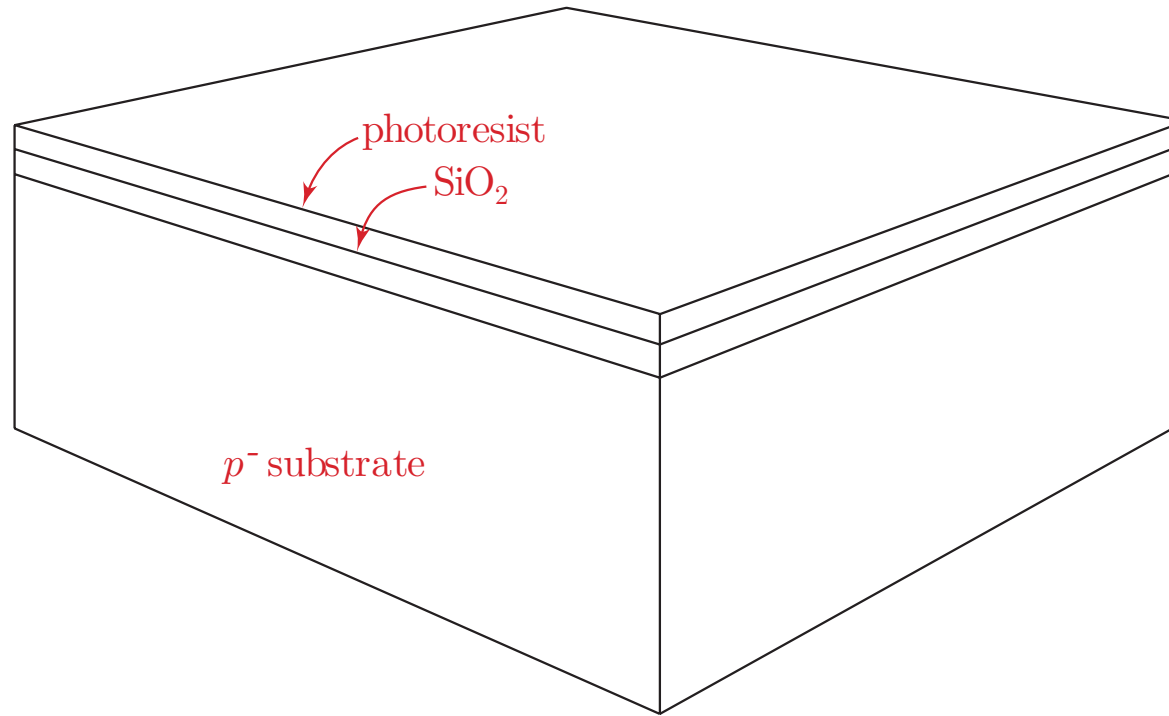

Oxidize silicon surface and coat with photoresist

CMOS Fabrication

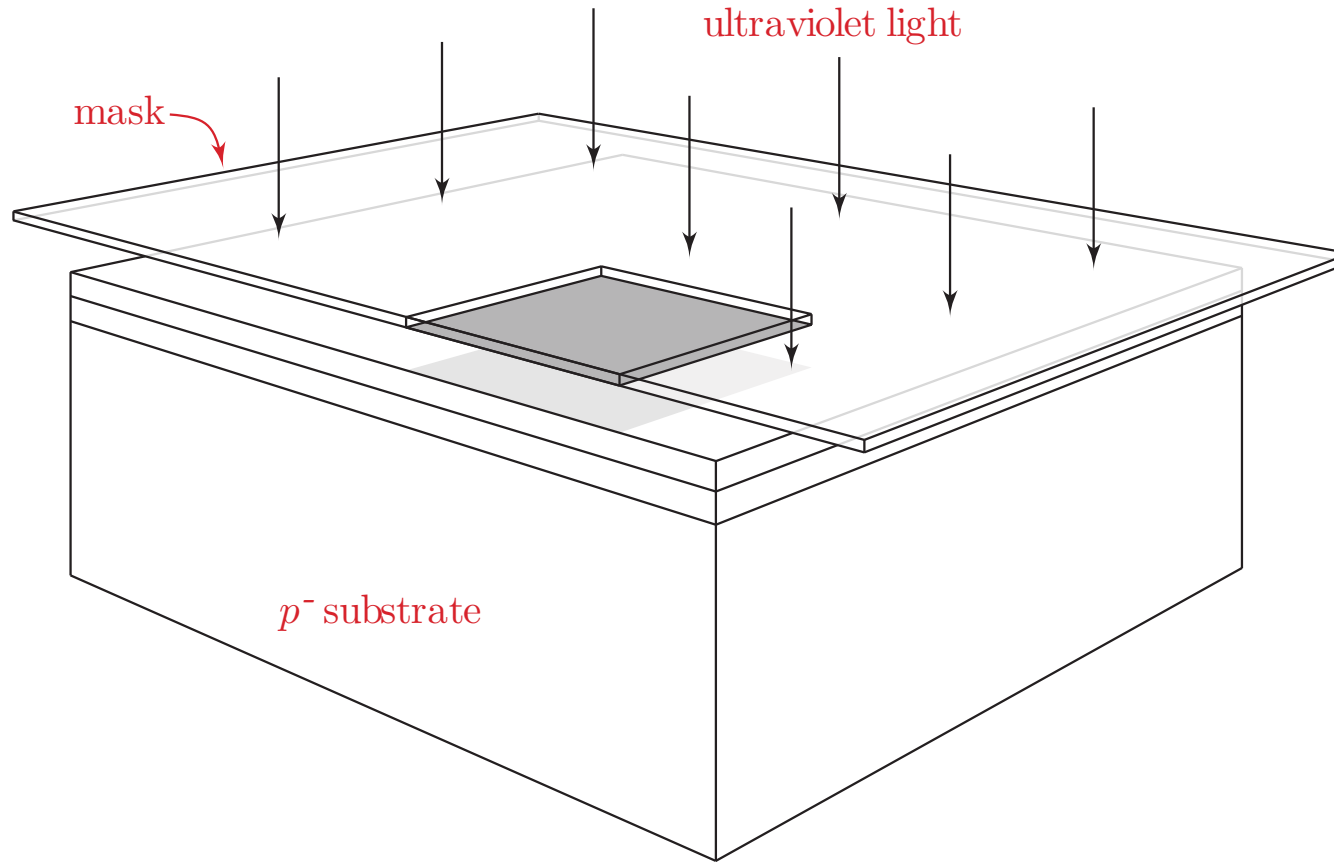

Pattern and selectively etch oxide layer

CMOS Fabrication

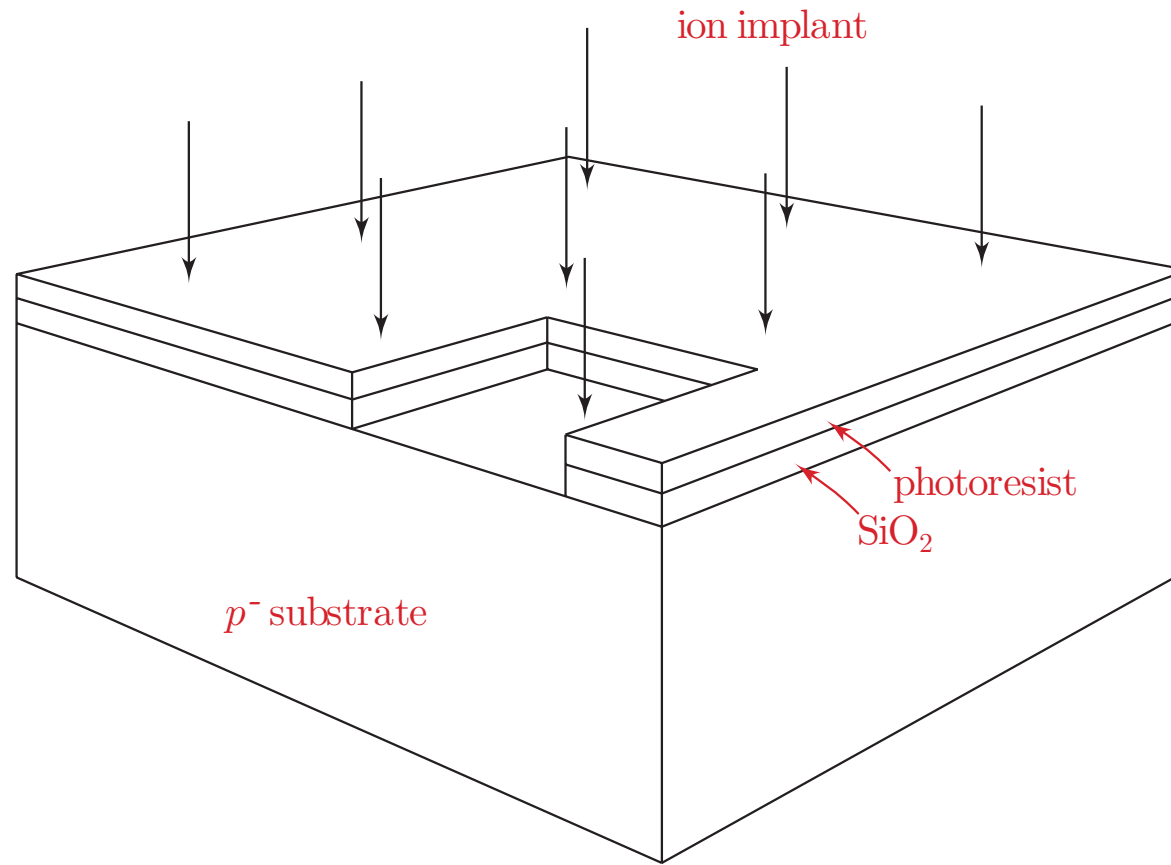

Ion implant for n -well regions

CMOS Fabrication

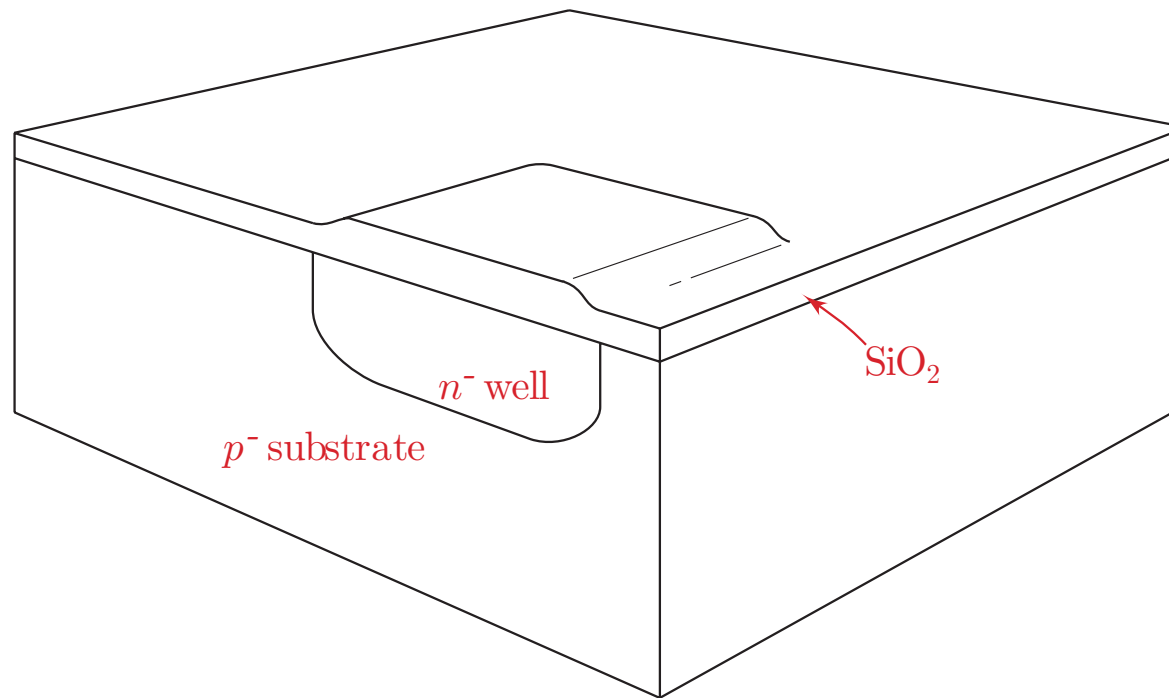

Anneal n -well implant and grow oxide

CMOS Fabrication

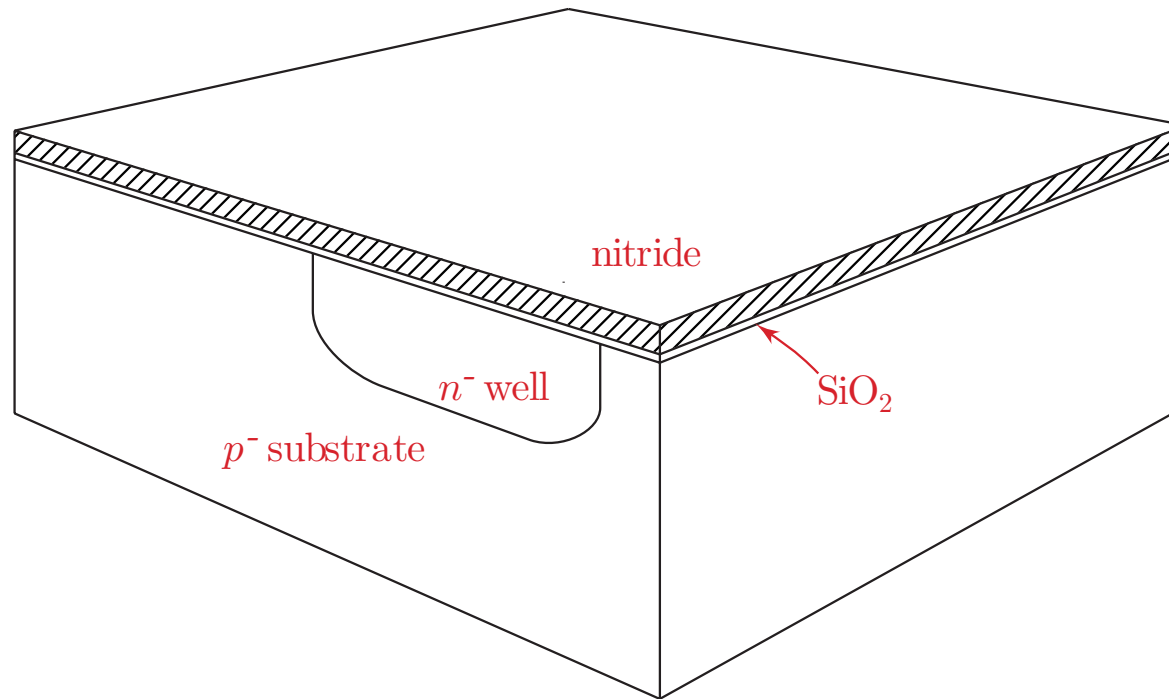

Remove all oxide, regrow thin oxide, and deposit nitride layer

CMOS Fabrication

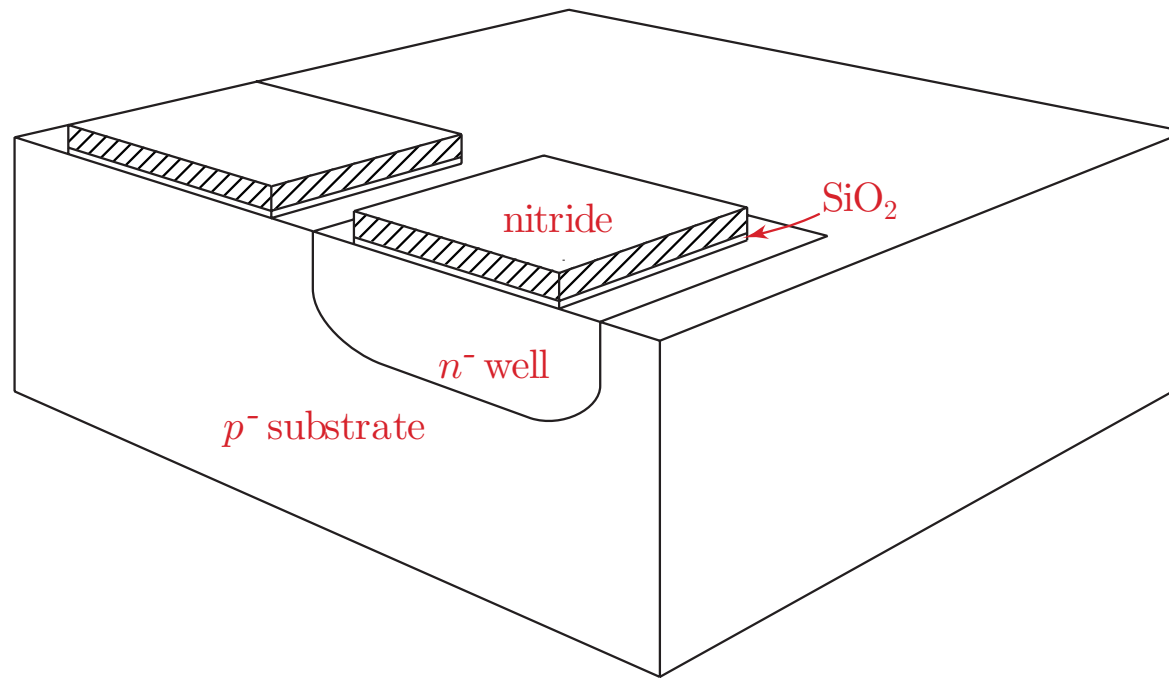

Pattern and selectively etch oxide and nitride layers

CMOS Fabrication

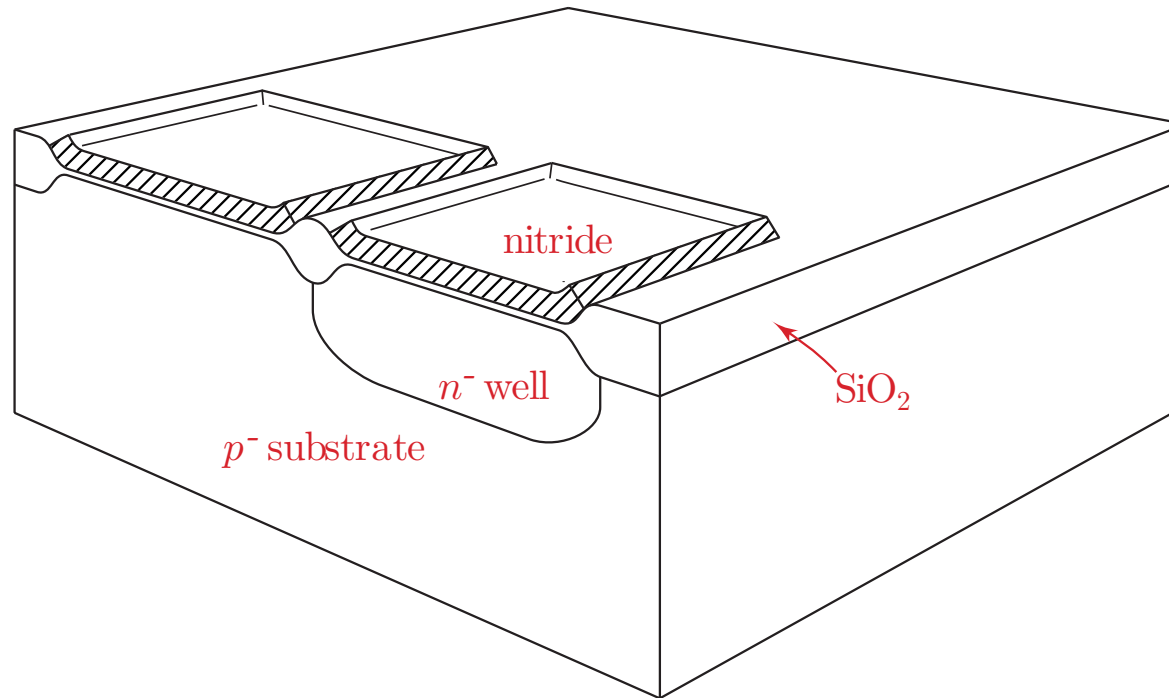

Grow field oxide in areas without nitride

CMOS Fabrication

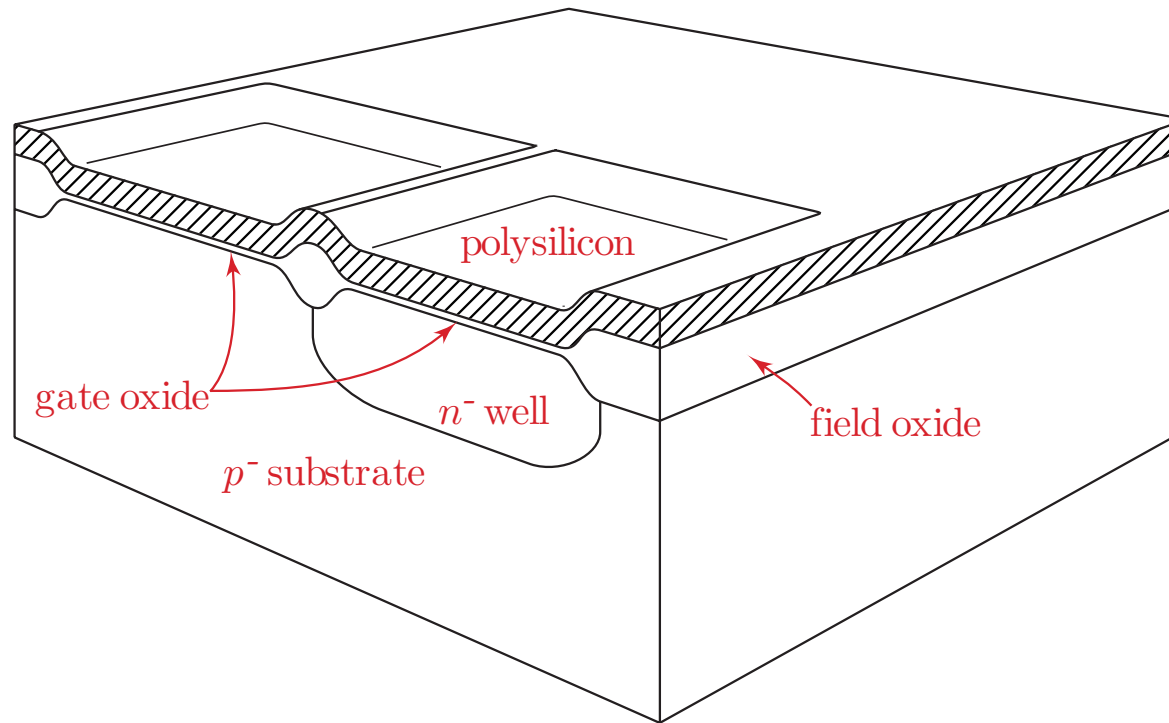

Remove nitride and thin oxide, grow gate oxide, and deposit poly

CMOS Fabrication

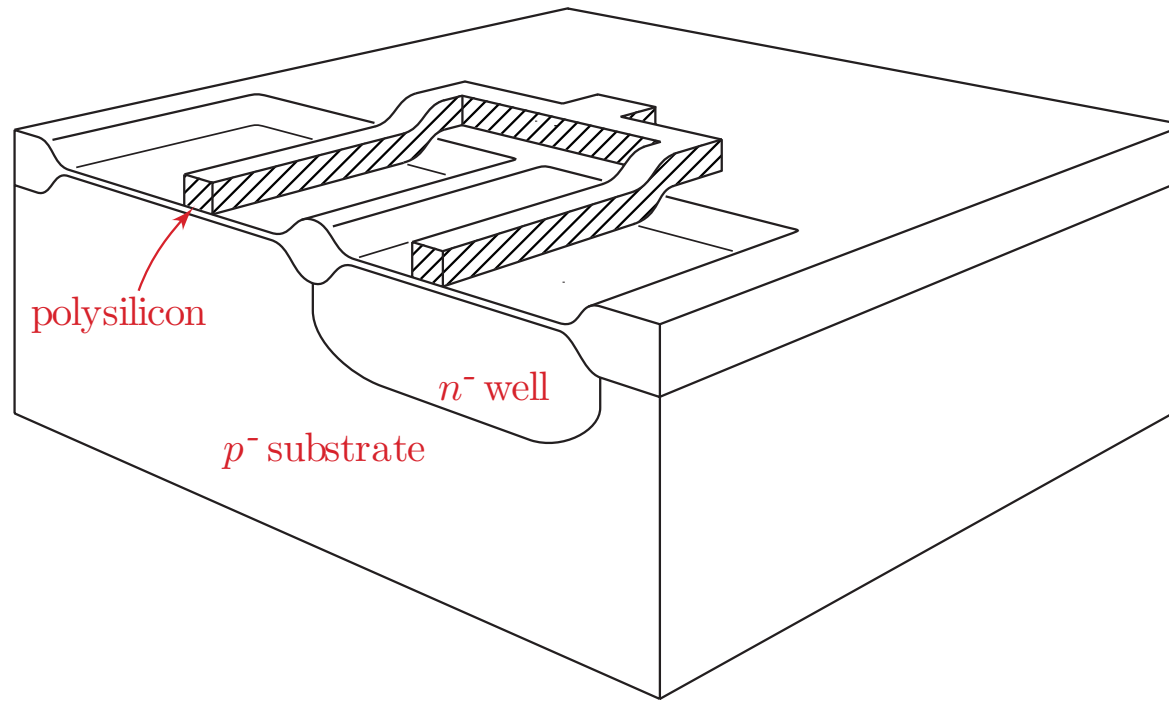

Pattern and selectively etch polysilicon

CMOS Fabrication

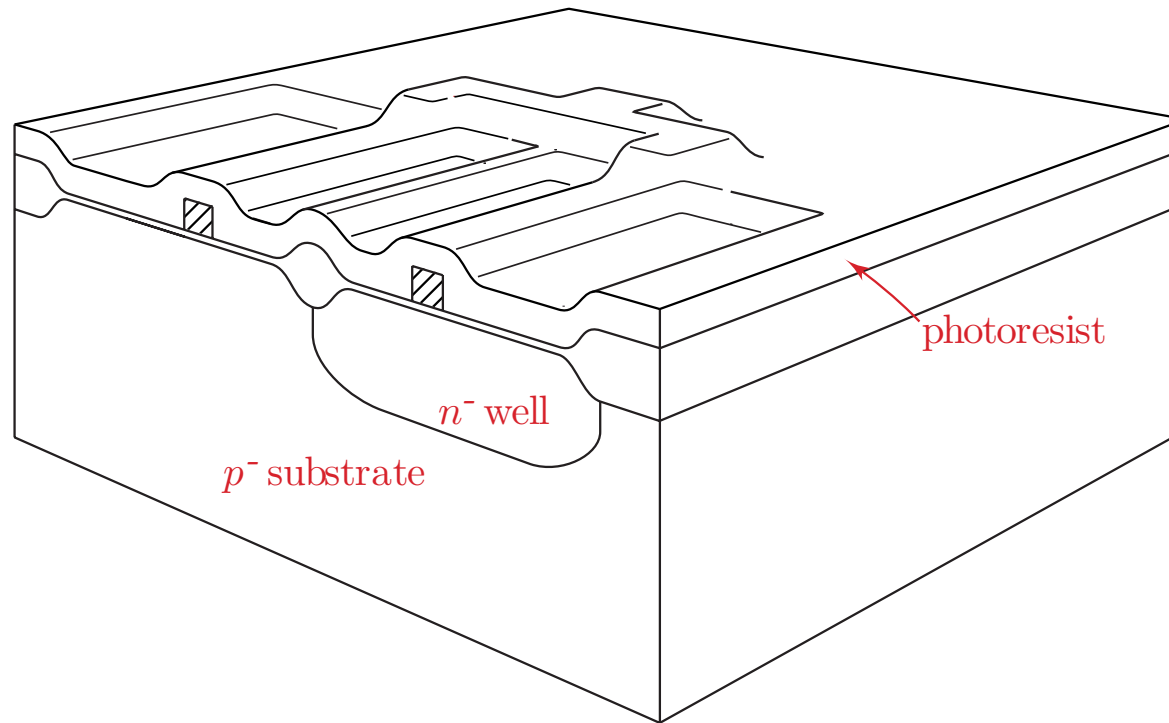

Conformally coat entire surface with photoresist

CMOS Fabrication

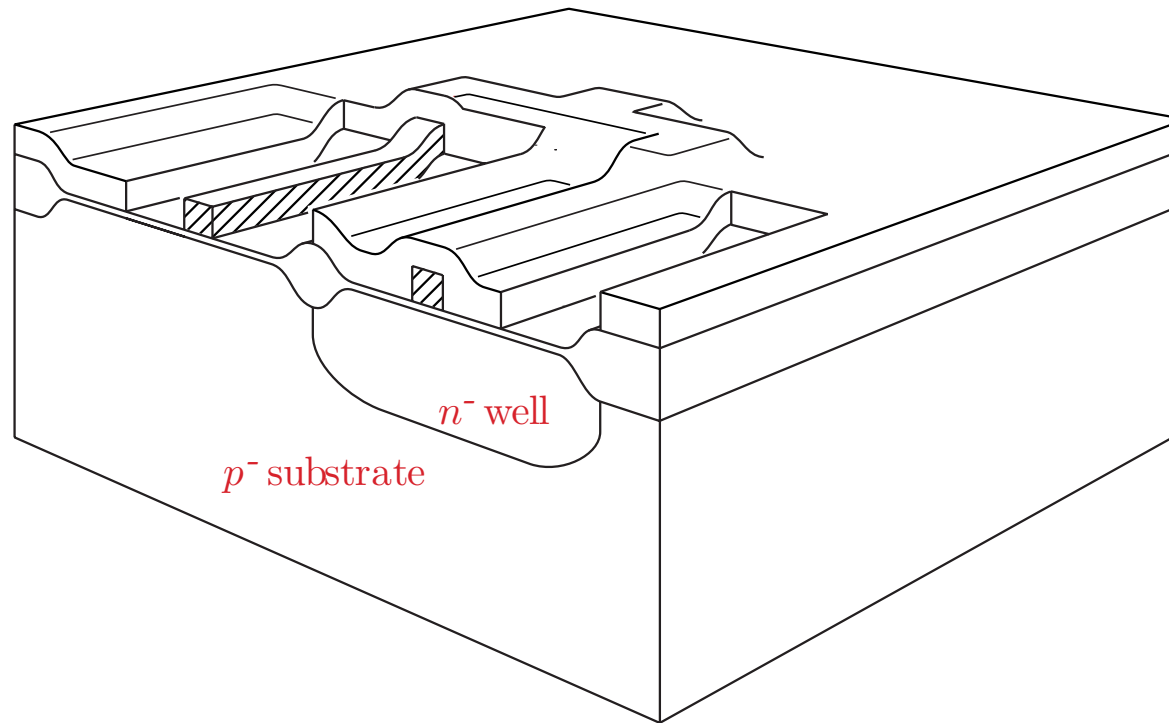

Remove photoresist to expose regions for n^+ implant

CMOS Fabrication

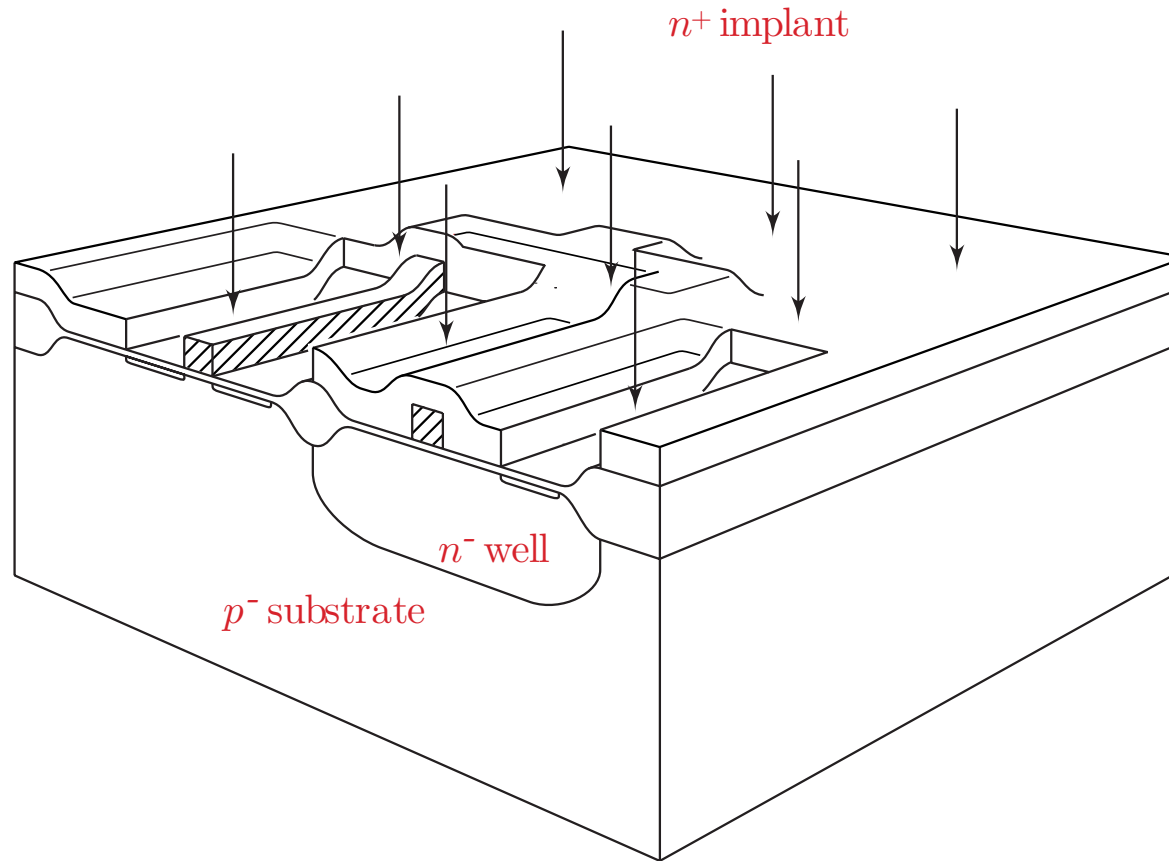

Ion implant for n^+ regions and remove all photoresist

CMOS Fabrication

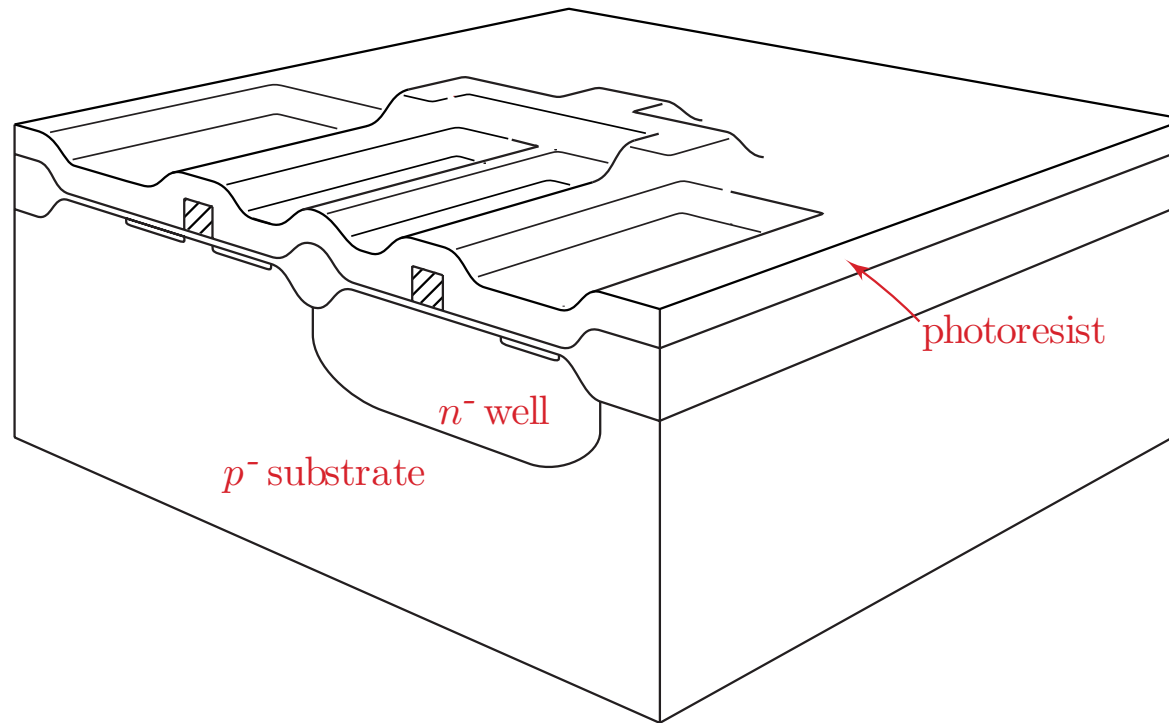

Conformally coat entire surface with photoresist

CMOS Fabrication

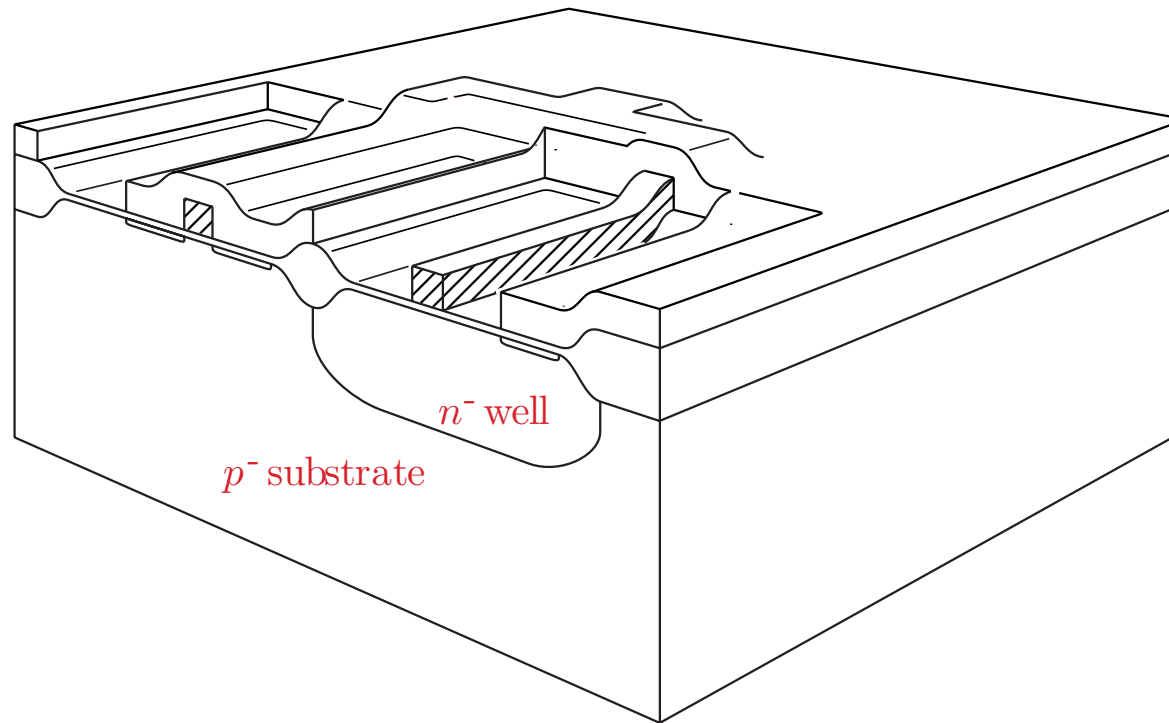

Remove photoresist to expose regions for p^+ implant

CMOS Fabrication

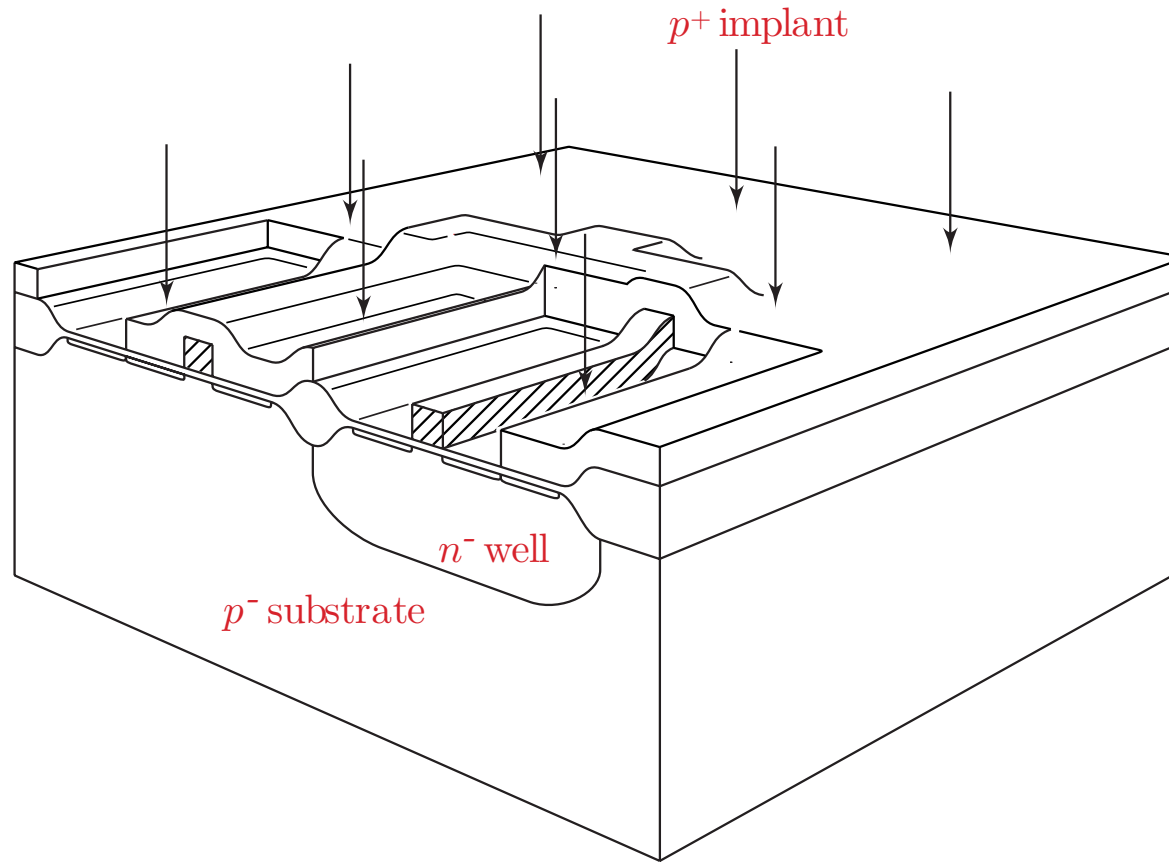

Ion implant for p^+ regions and remove all photoresist

CMOS Fabrication

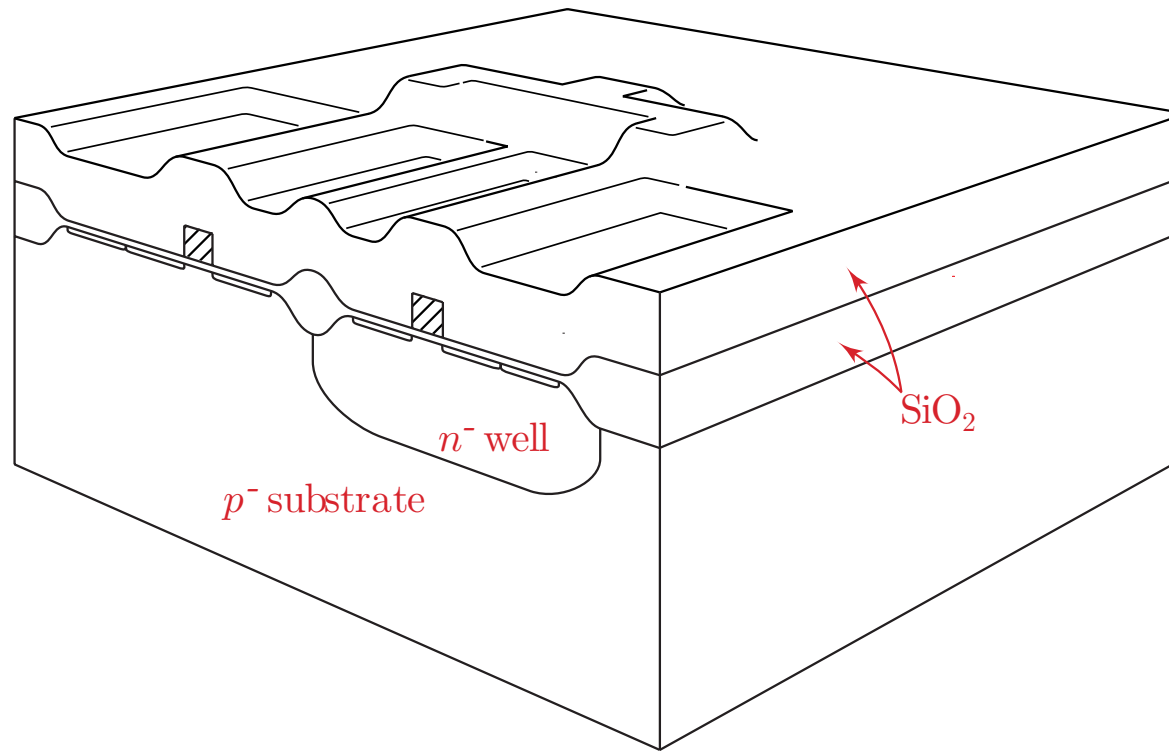

Deposit thick oxide layer over entire surface

CMOS Fabrication

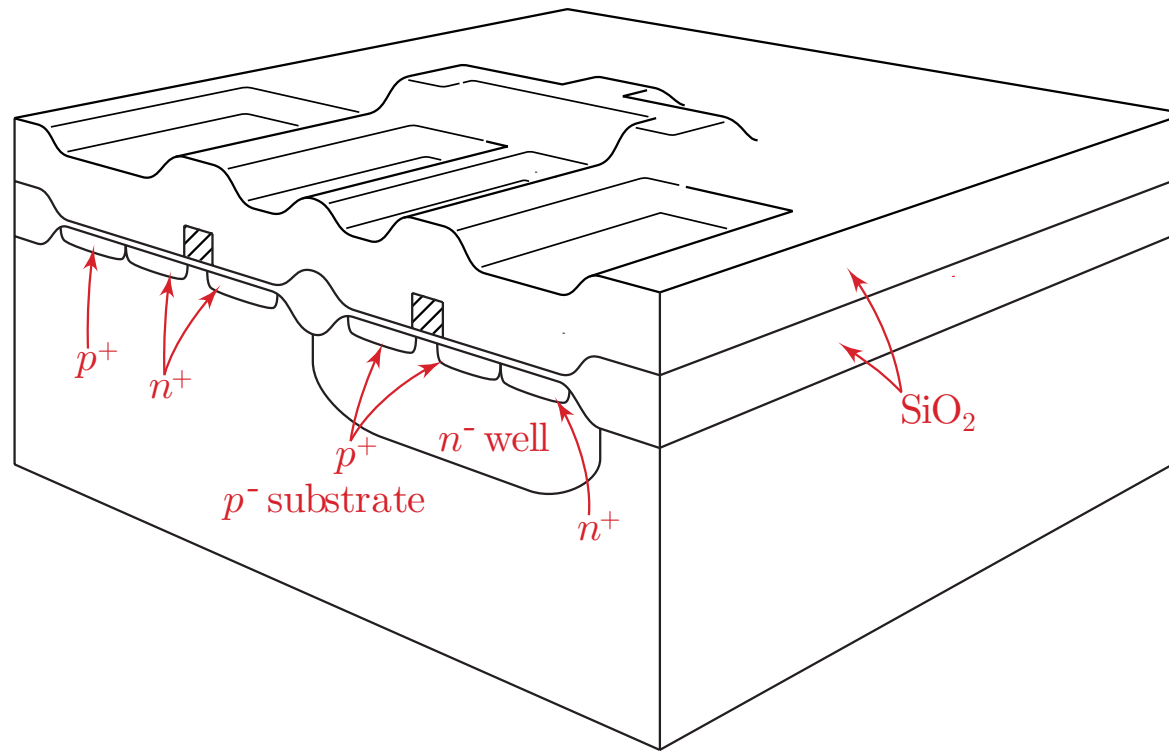

Anneal and drive in both implants

CMOS Fabrication

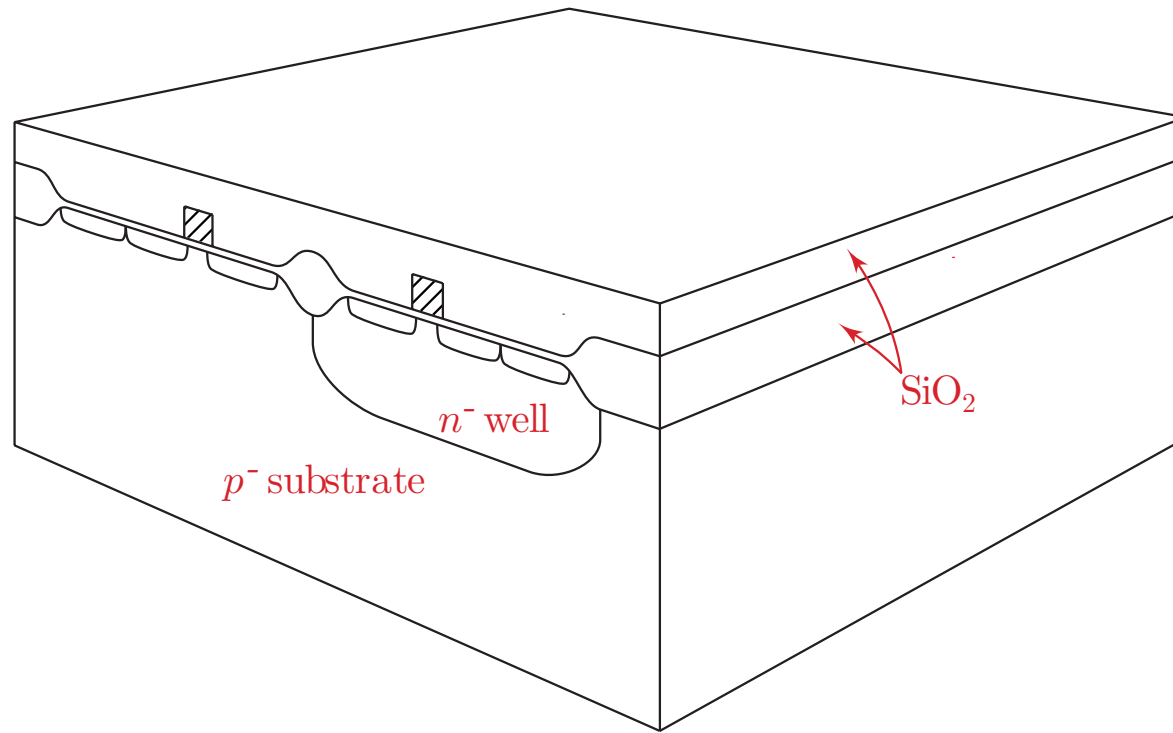

Planarize surface by chemical-mechanical polishing

CMOS Fabrication

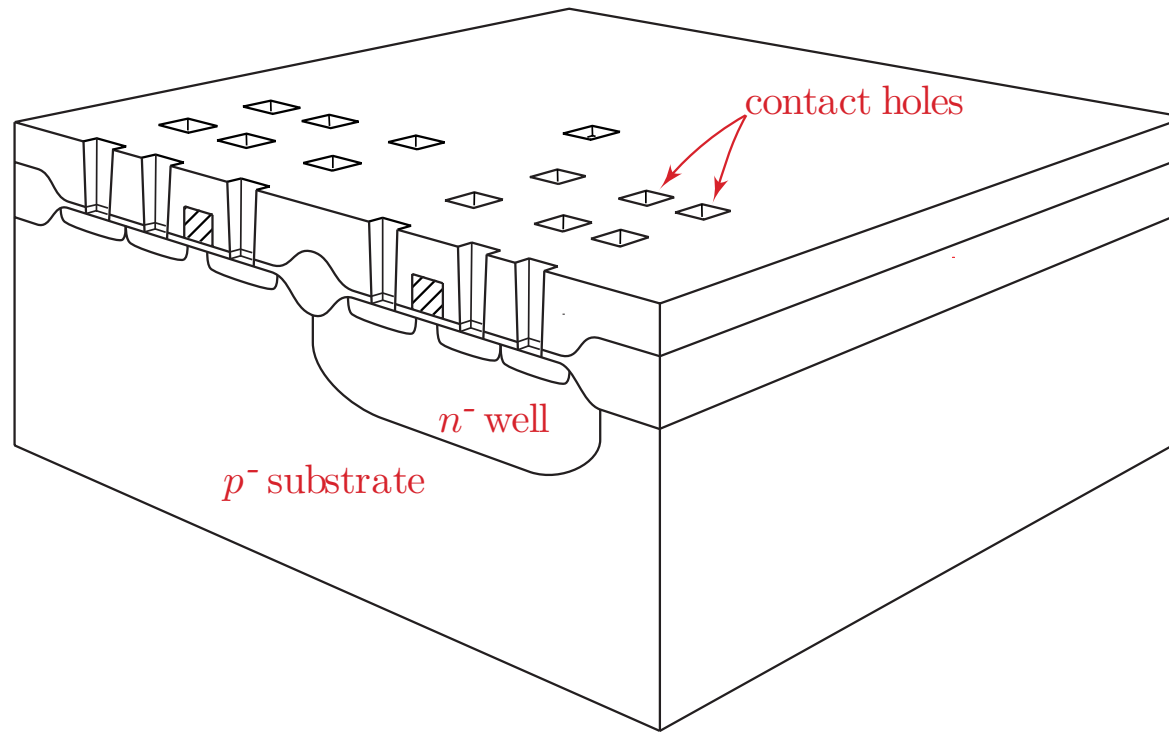

Open contact windows in the oxide

CMOS Fabrication

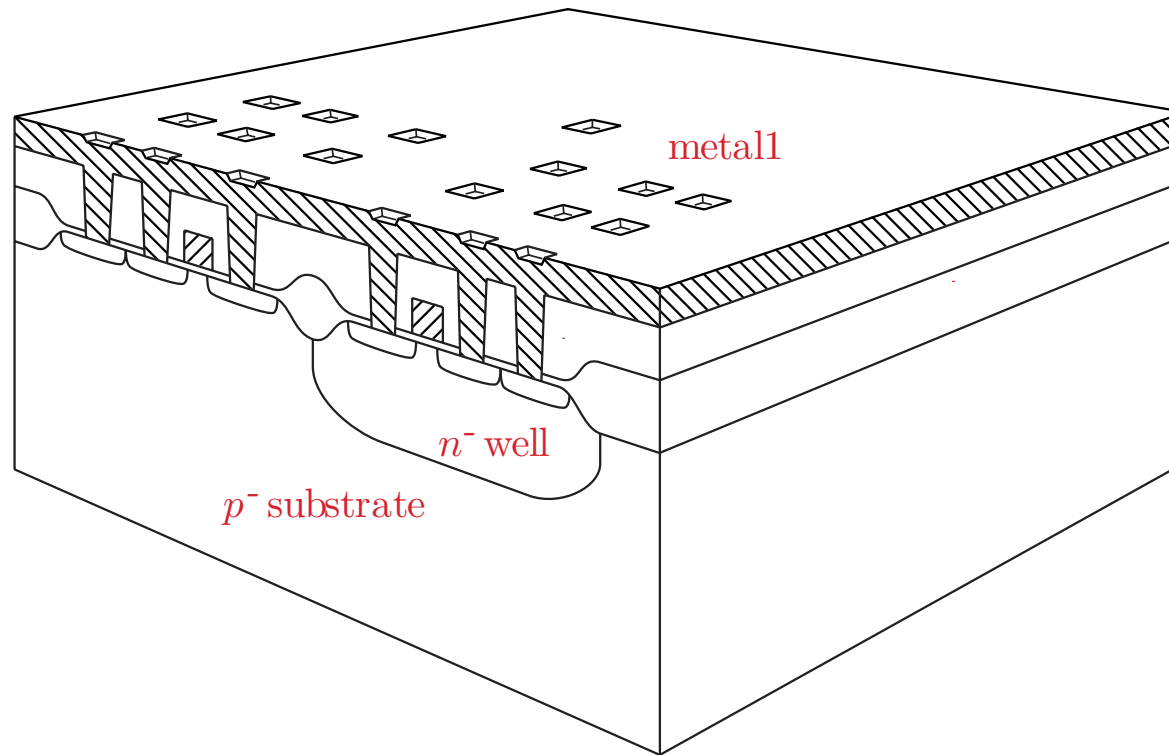

Fill contact holes with metal and deposit metal1

CMOS Fabrication

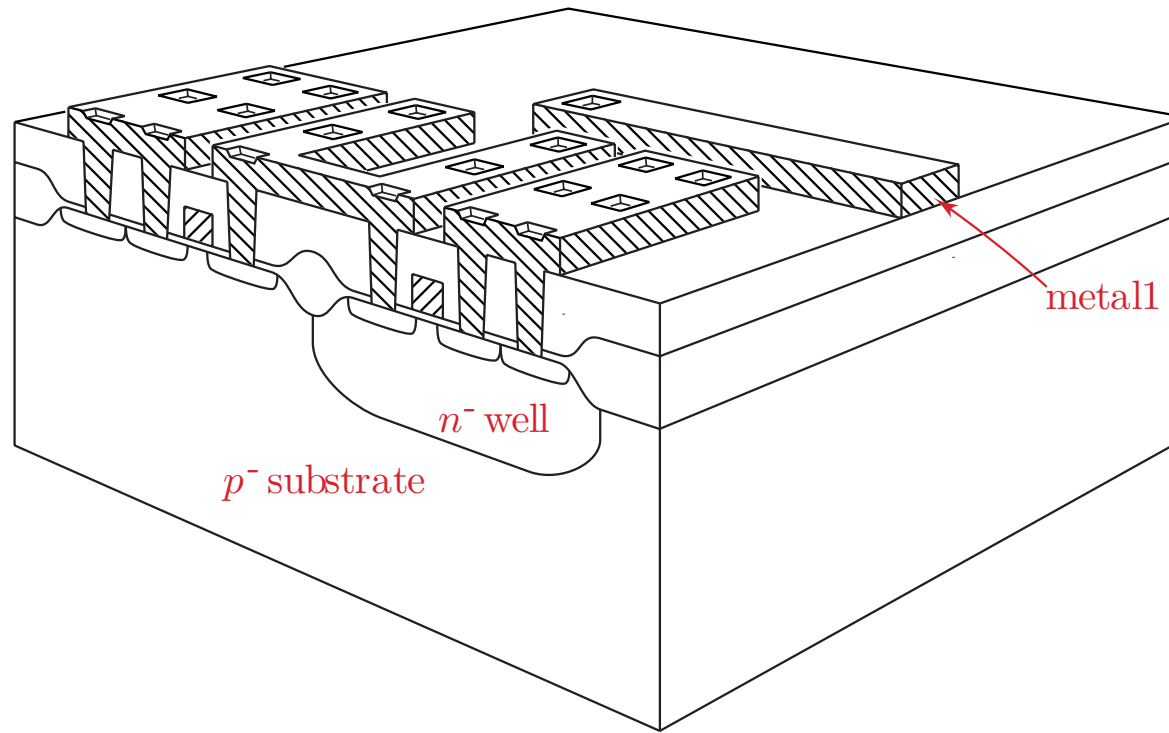

Pattern and selectively etch metal1

CMOS Fabrication

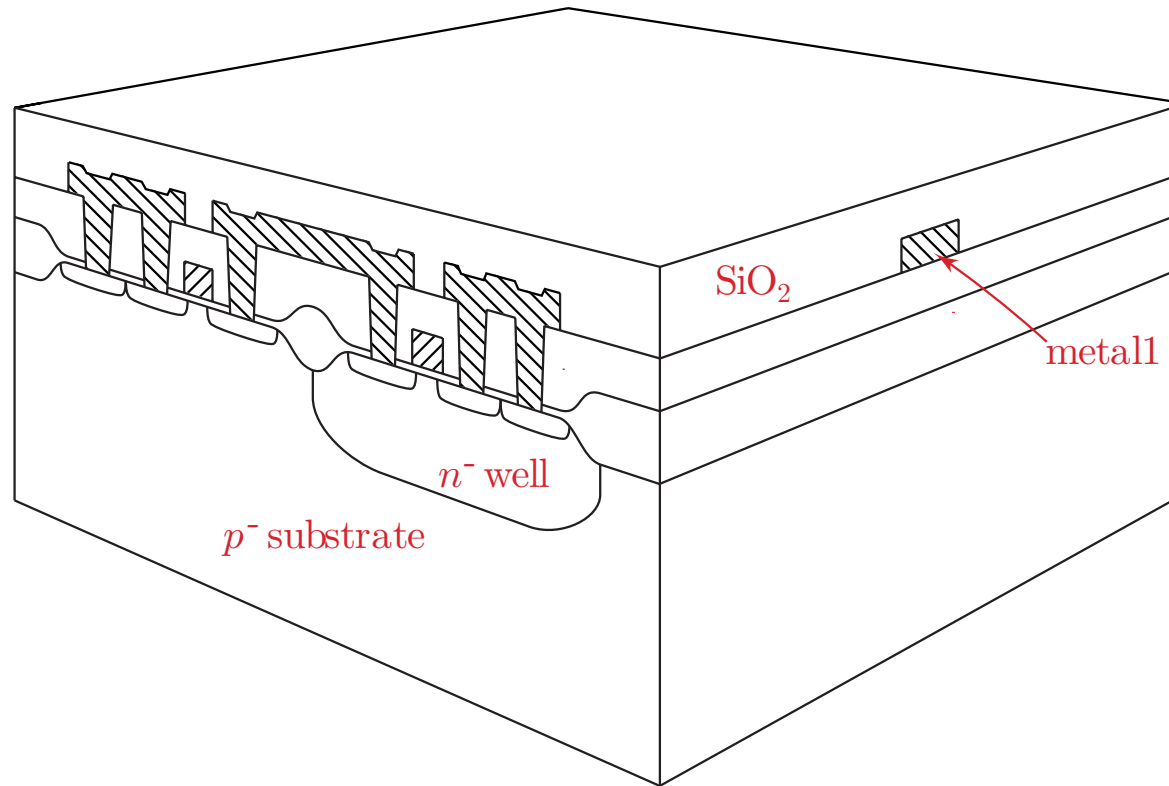

Planarize surface by chemical-mechanical polishing

CMOS Fabrication

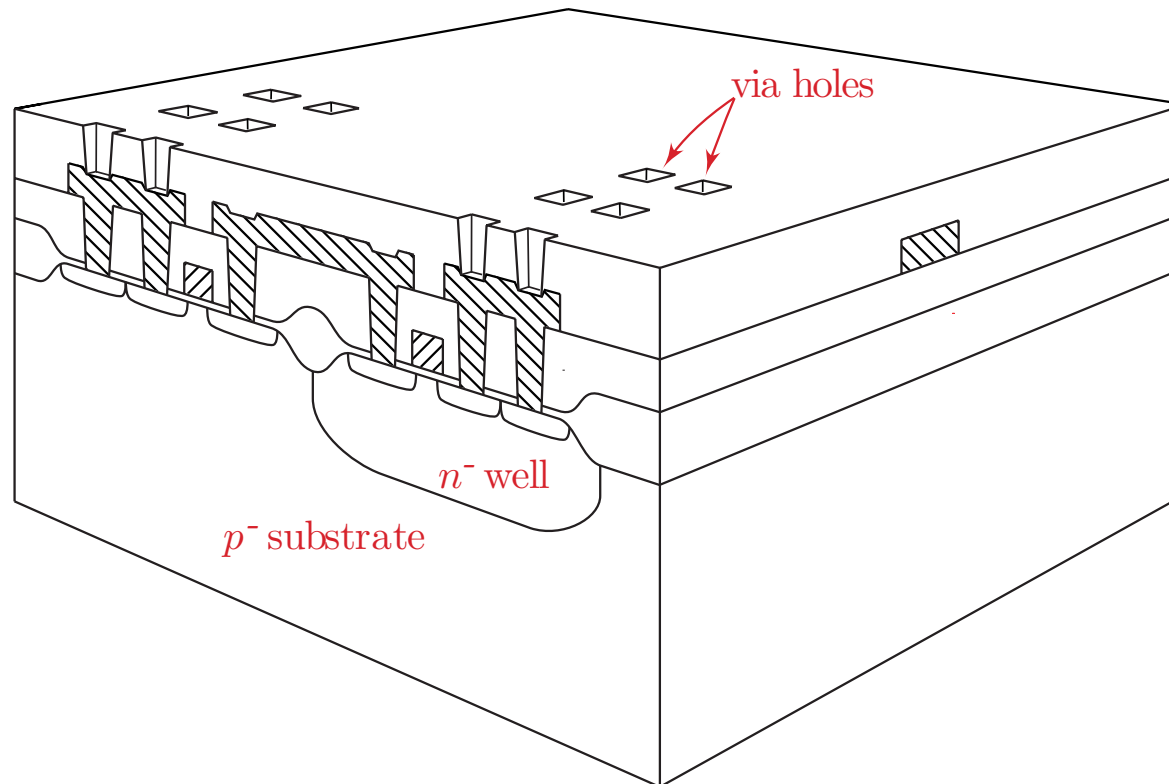

Open via windows in the oxide

CMOS Fabrication

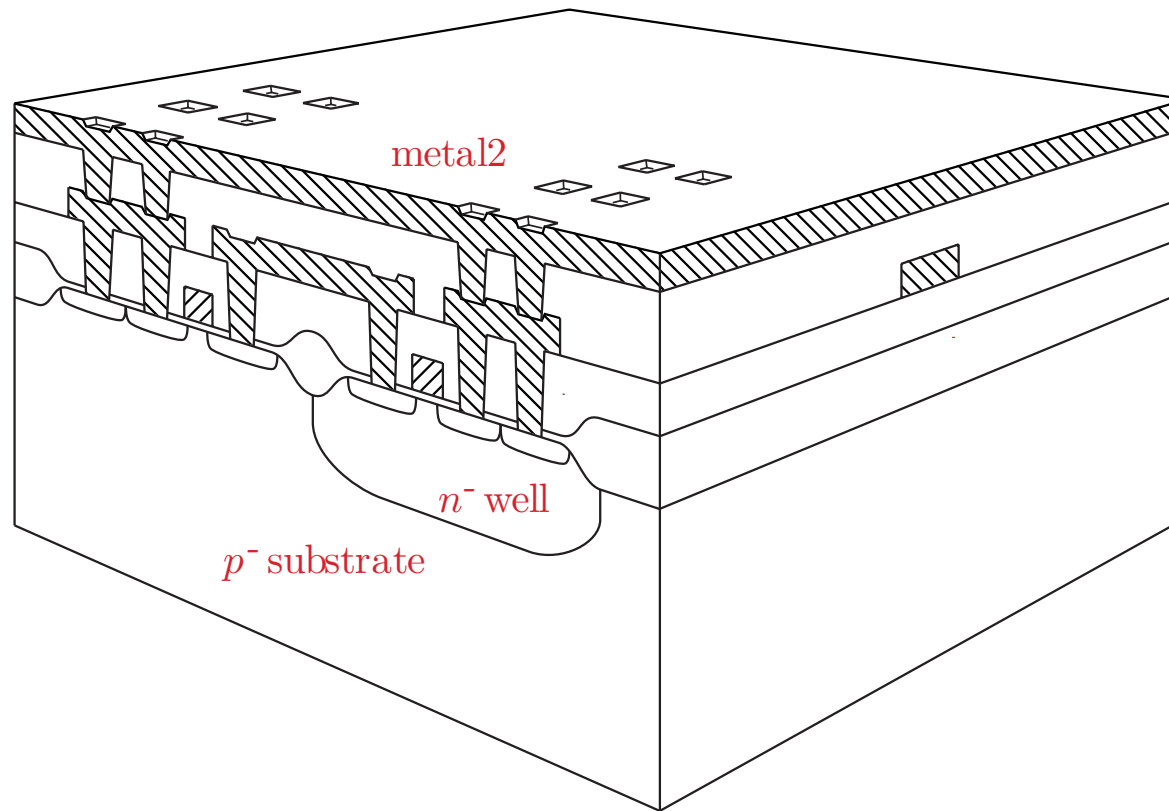

Fill via holes with metal and deposit metal2

CMOS Fabrication

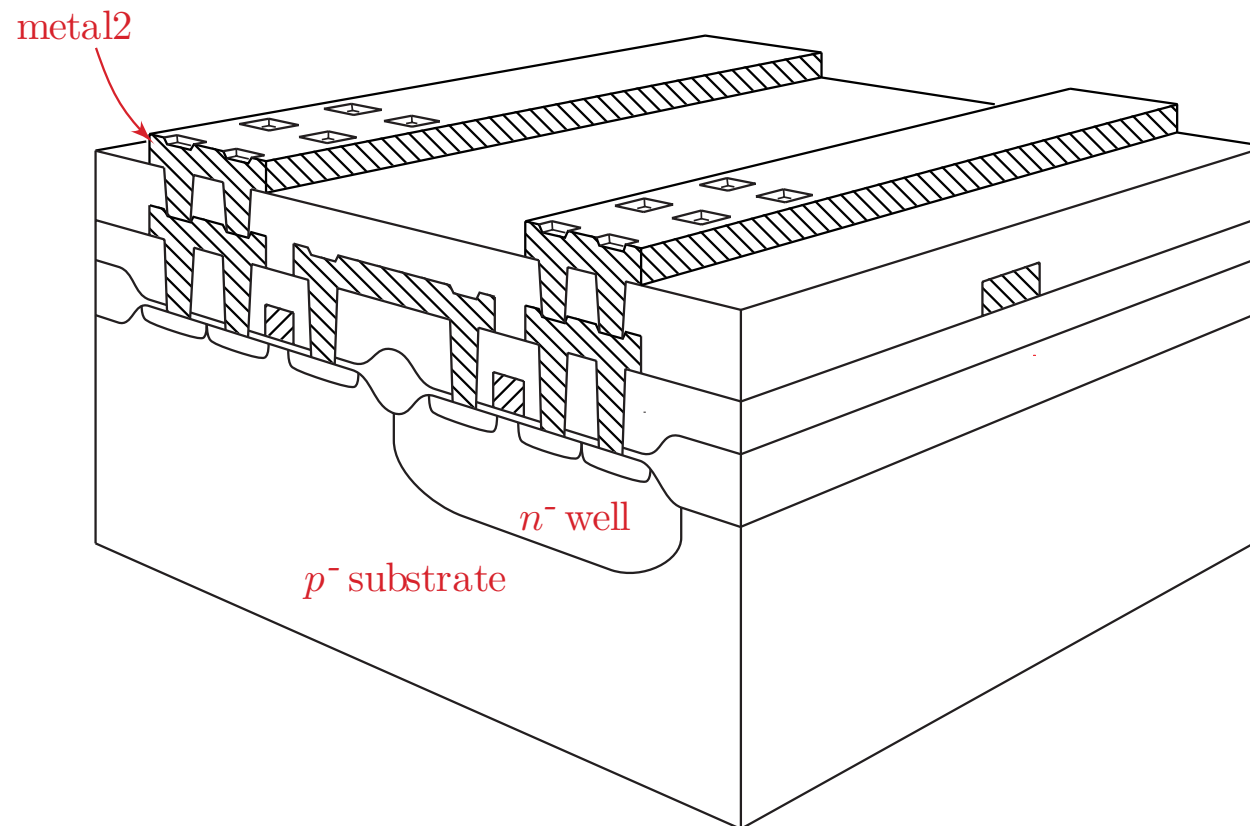

Pattern and selectively remove metal2

