



# CH4 Single TR Amp and Cascode Amp

4.2 Common source amplifier

4.3 Common gate amplifier

4.4 Common drain amplifier

4.5 Cascode amplifier



# Singe transistor amplifier

	Input Port	Output Port
Common Source	G-S	D-S
Common Gate	S-G	D-G
Common Drain	G-D	S-D

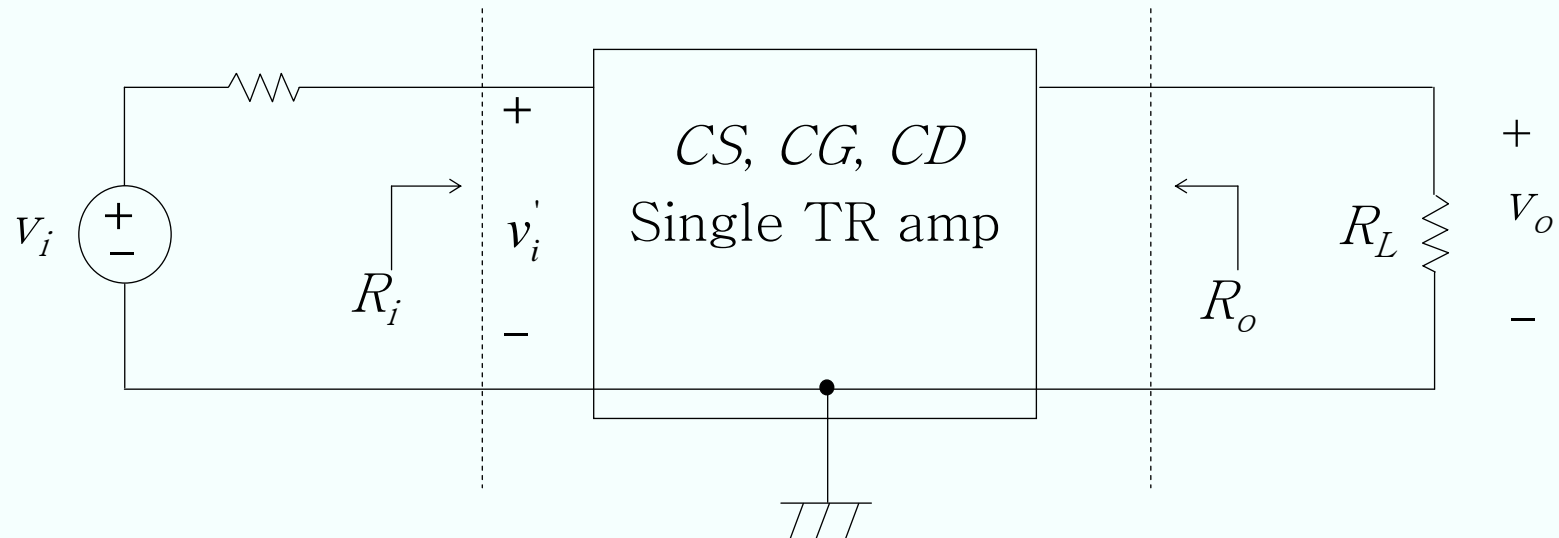

**Fig 4.5.1** 2-port representation of CS, CG, CD single transistor amp



	<b>CS amp</b>	<b>CG amp</b>	<b>CD amp</b>
$A'_v$	$-g_m \cdot (r_o \parallel R_L)$	$+(g_m + g_{mb}) \cdot (r_o \parallel R_L)$	$+\frac{g_m}{g_m + g_{mb} + \frac{1}{r_o \parallel R_L}}$
$R_i$	$\infty$	$\frac{1}{g_m + g_{mb} + \frac{1}{r_o}} \cdot \left(1 + \frac{R_L}{r_o}\right)$	$\infty$
$R_o$	$r_o$	$r_o + R_s + (g_m + g_{mb}) \cdot r_o \cdot R_s$	$\frac{1}{g_m + g_{mb}}$
$\omega_{-3dB}$	$\frac{1}{R_s \cdot \left\{ C_{GD} \cdot g_m (r_o \parallel R_L) + C_{GS} \right\} + C_{GB} + C_{GD}}$	$\frac{1}{(R_s \parallel R_i) \cdot (C_{GS} + C_{SB})}$	$\frac{1}{R_s \cdot \left\{ C_{GD} + C_{GB} + C_{GS} \cdot \frac{g_{mb}}{g_m + g_{mb}} \right\}}$
<b>Linear input voltage range (distortion &lt; 10%)</b>	$ v'_i  < 0.2(V_{GS} - V_{TH})$	$ v'_i  < 0.2(V_{GS} - V_{TH})$	$ v'_i  < \left\{ \frac{g_m + g_{mb}}{g_{mb}} \right\} \cdot 0.2(V_{GS} - V_{TH})$
<b>Suitable amp type</b>	<b>Voltage Input Current Output</b>	<b>Current Input Current Output</b>	<b>Voltage Input Voltage Output</b>



## 4.2 common source amplifier

Input ports: G – S

Output ports: D – S

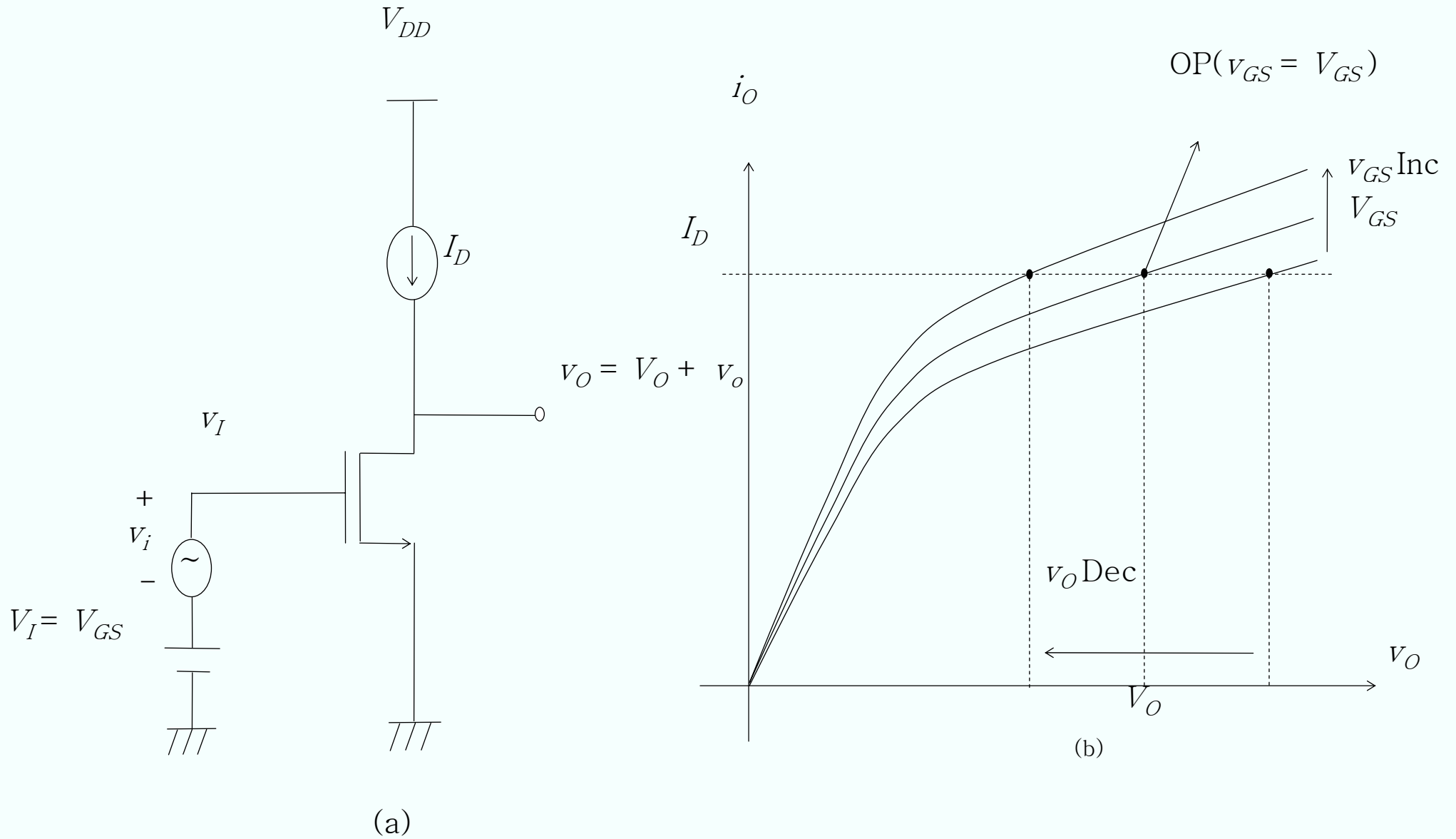

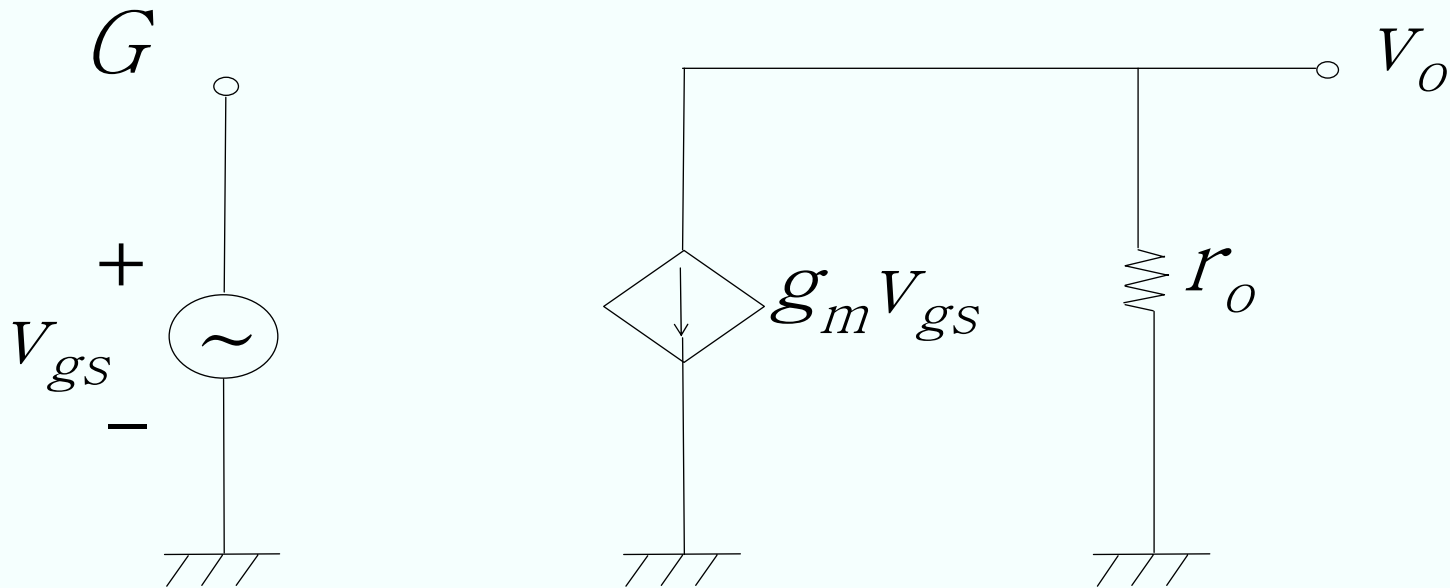

$$A_v \triangleq \frac{v_o}{v_{gs}} = -g_m r_o = -\frac{\sqrt{2\mu C_{ox} \frac{W}{L}}}{\lambda \cdot \sqrt{I_D}}$$

$$|A_v| \propto \frac{\sqrt{WL}}{\sqrt{I_D}}$$

$g_m \times r_o = \text{Intrinsic Voltage Gain}$

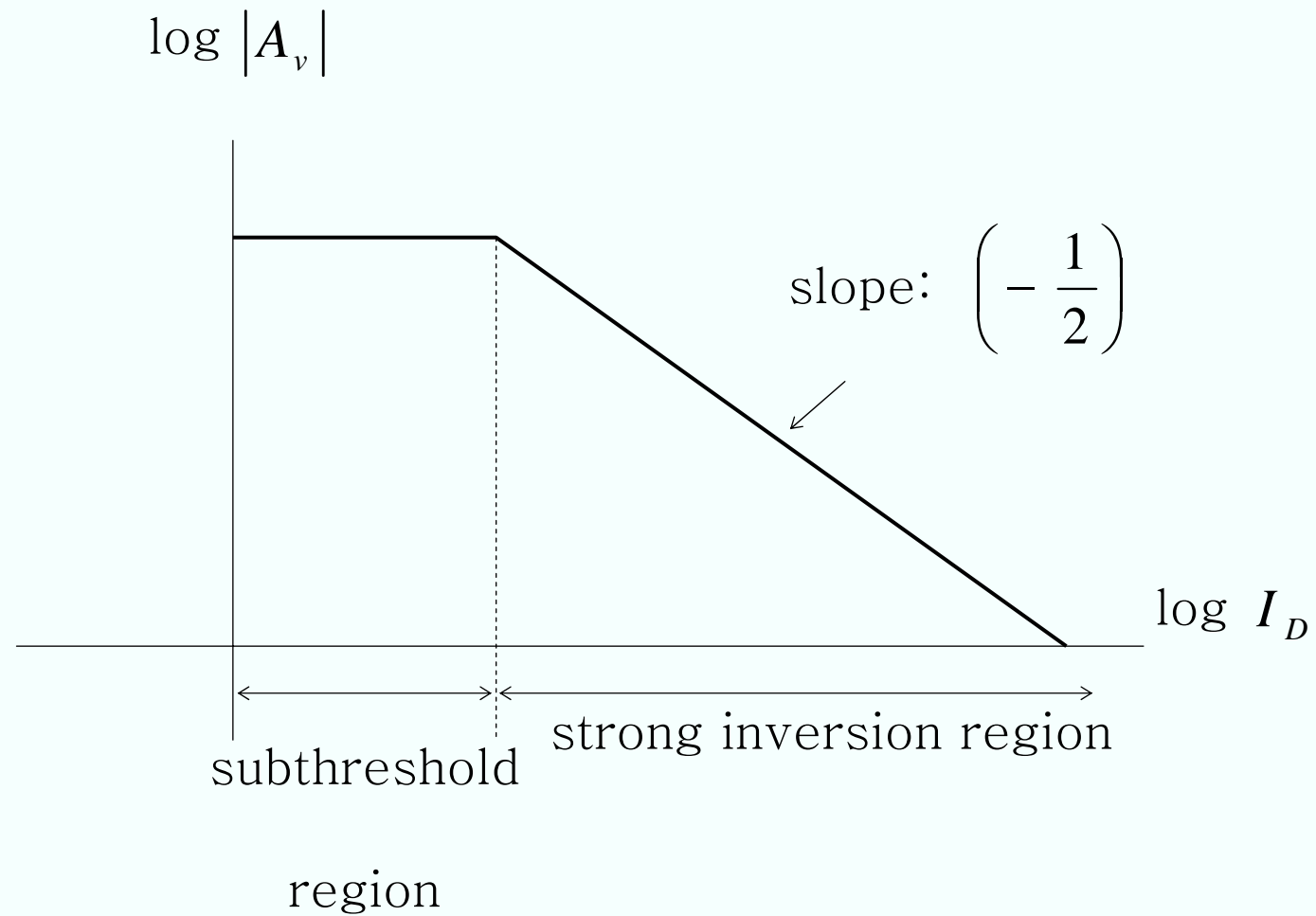

**Fig 4.2.2** Small-signal voltage gain versus DC drain current at OP (log-log plot)



$$I_D = K \cdot e^{\frac{V_{GS} - V_{TH}}{nV_T}}$$

Similar to BJT

$$g_m = \frac{I_D}{nV_T}$$

$$r_o = \frac{1}{\lambda I_D}$$

$$|A_v| = g_m r_o$$

$$= \frac{\left(\frac{1}{\lambda}\right)}{nV_T} \propto L$$

Large  $A_v$ , but Slow frequency response, Large offset → not used often

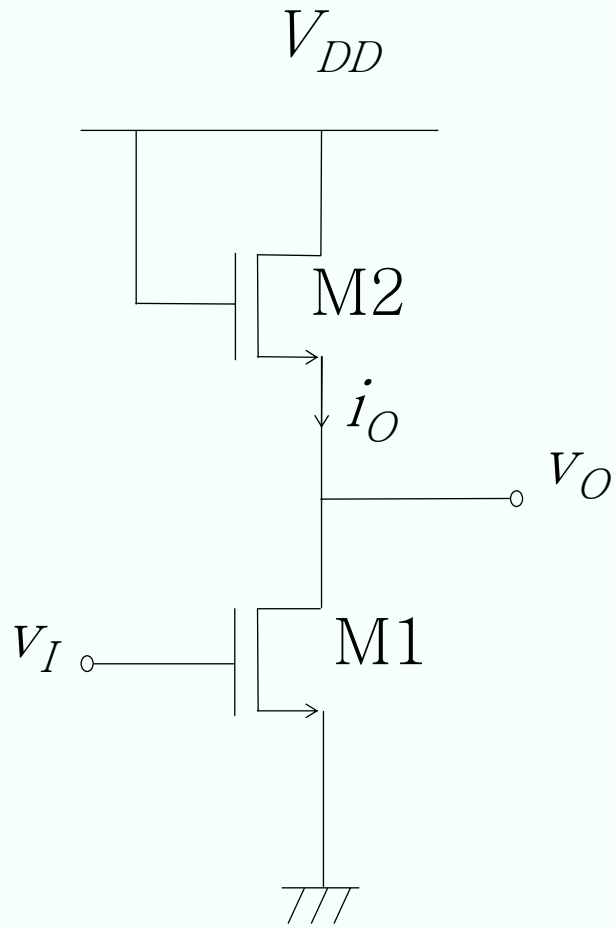

(a)

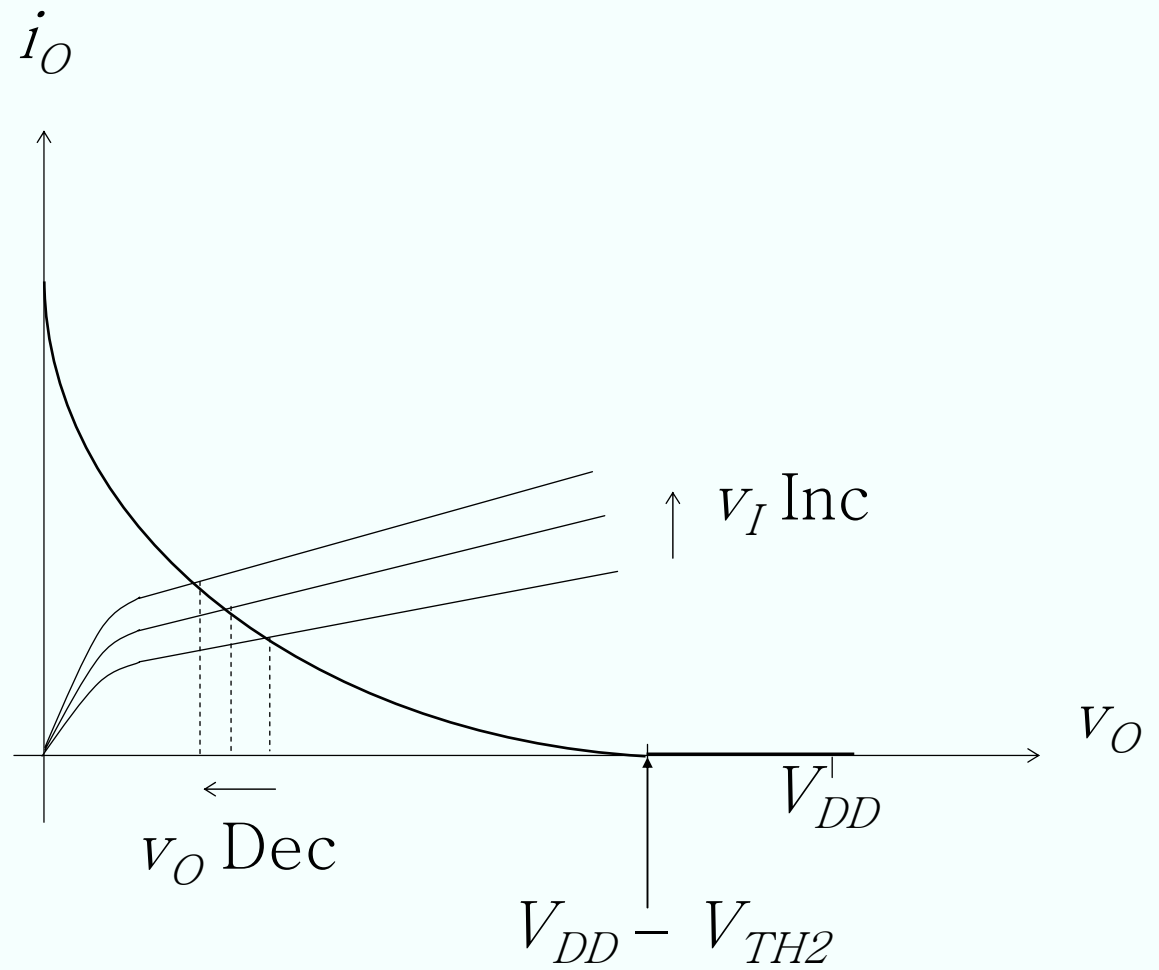

(b)

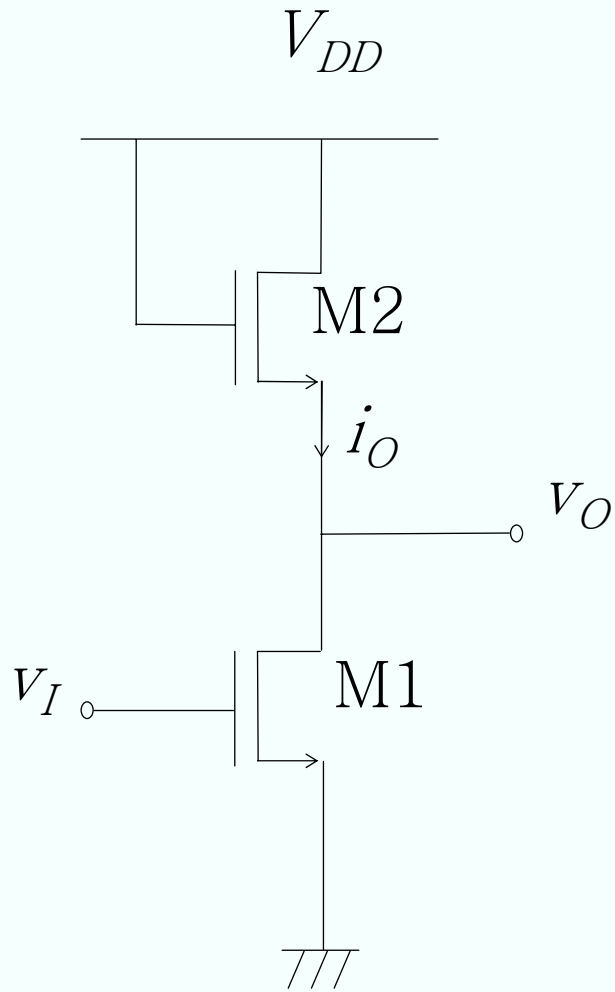

(a)

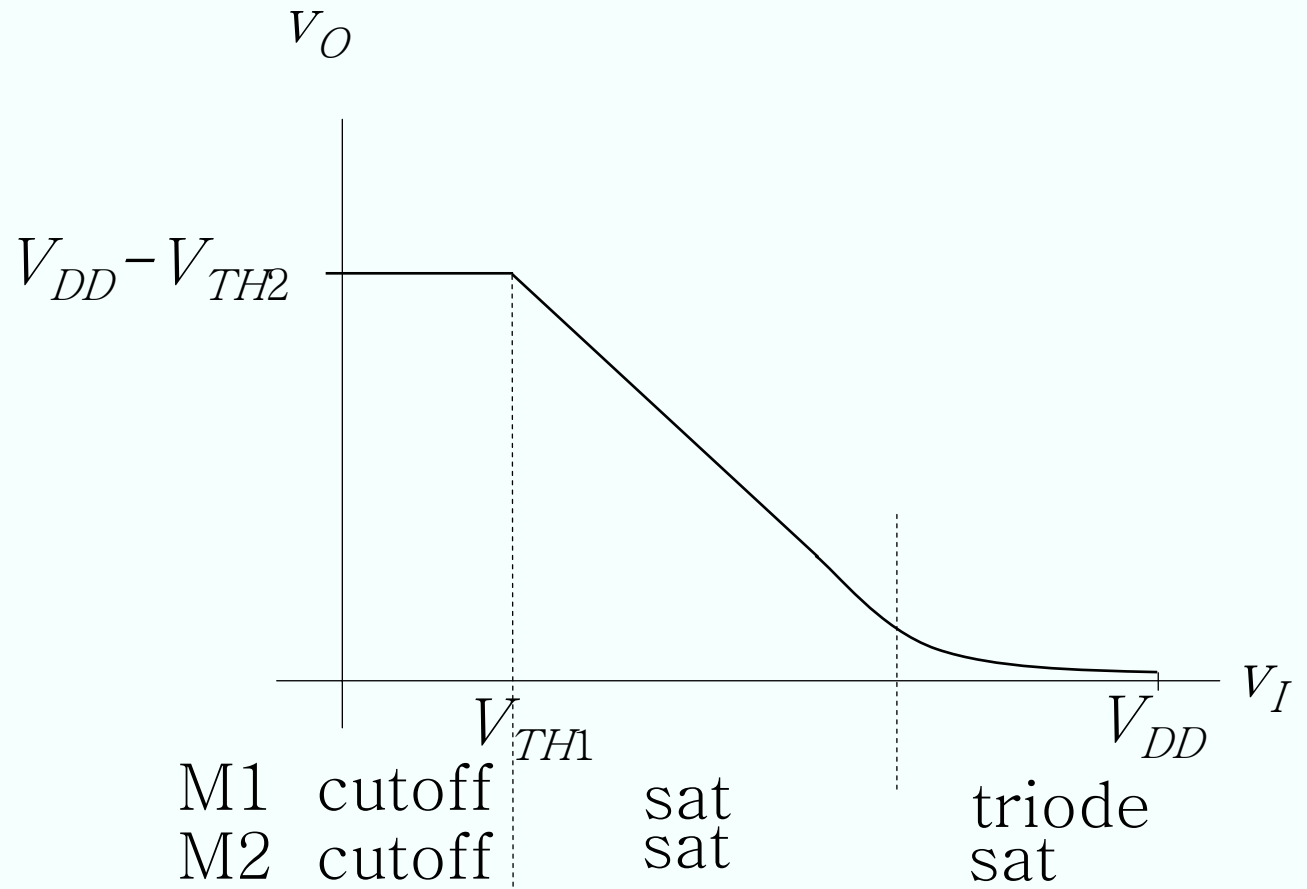

(c)

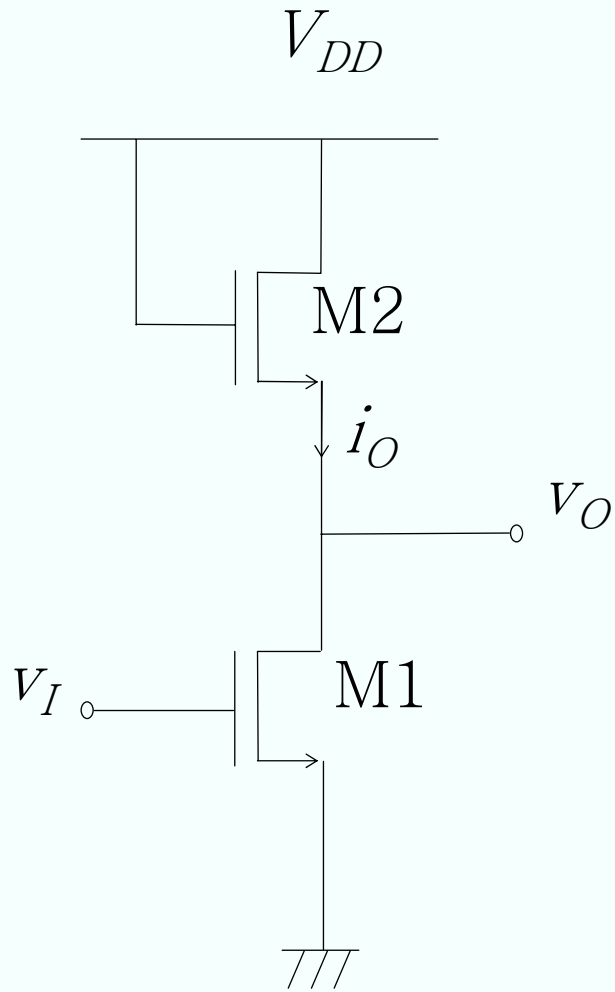

(a)

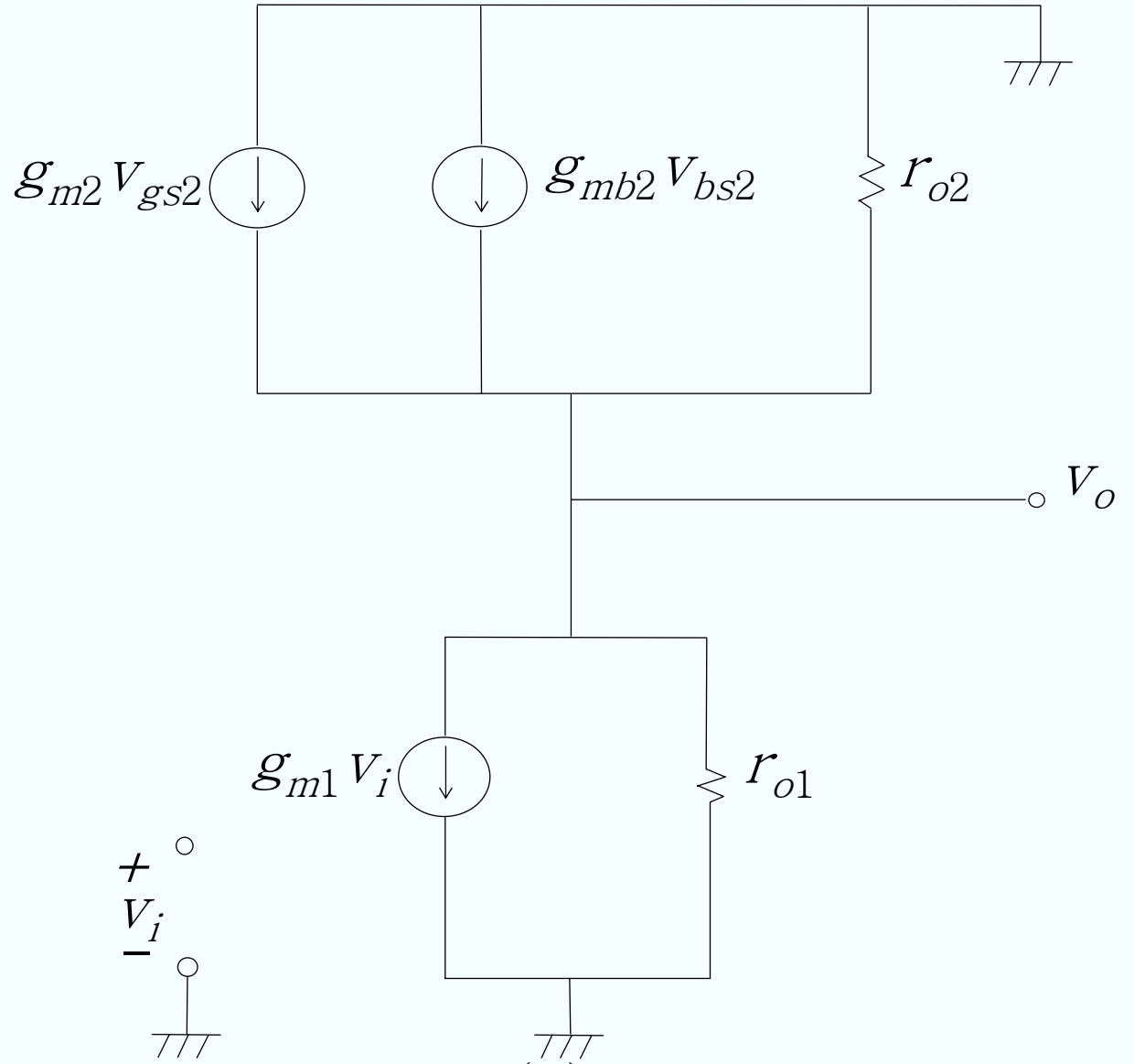

(d)



$$\frac{v_o}{v_i} = - \frac{g_{m1}}{g_{m2} + g_{mb2} + \frac{1}{r_{o1}} + \frac{1}{r_{o2}}}$$

$$A_v \approx - \frac{g_{m1}}{g_{m2}} = - \sqrt{\frac{(W/L)_1}{(W/L)_2}}$$

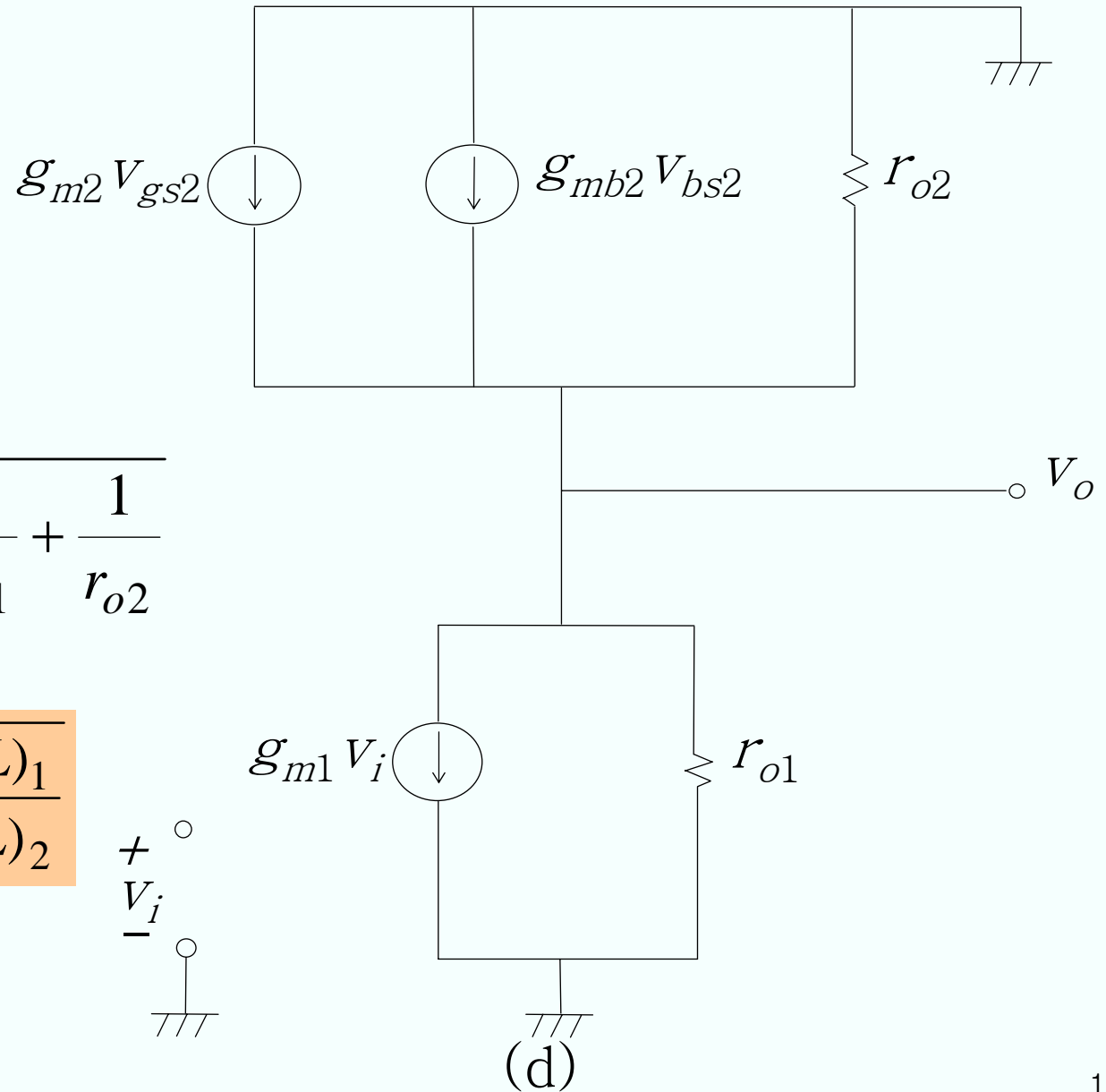

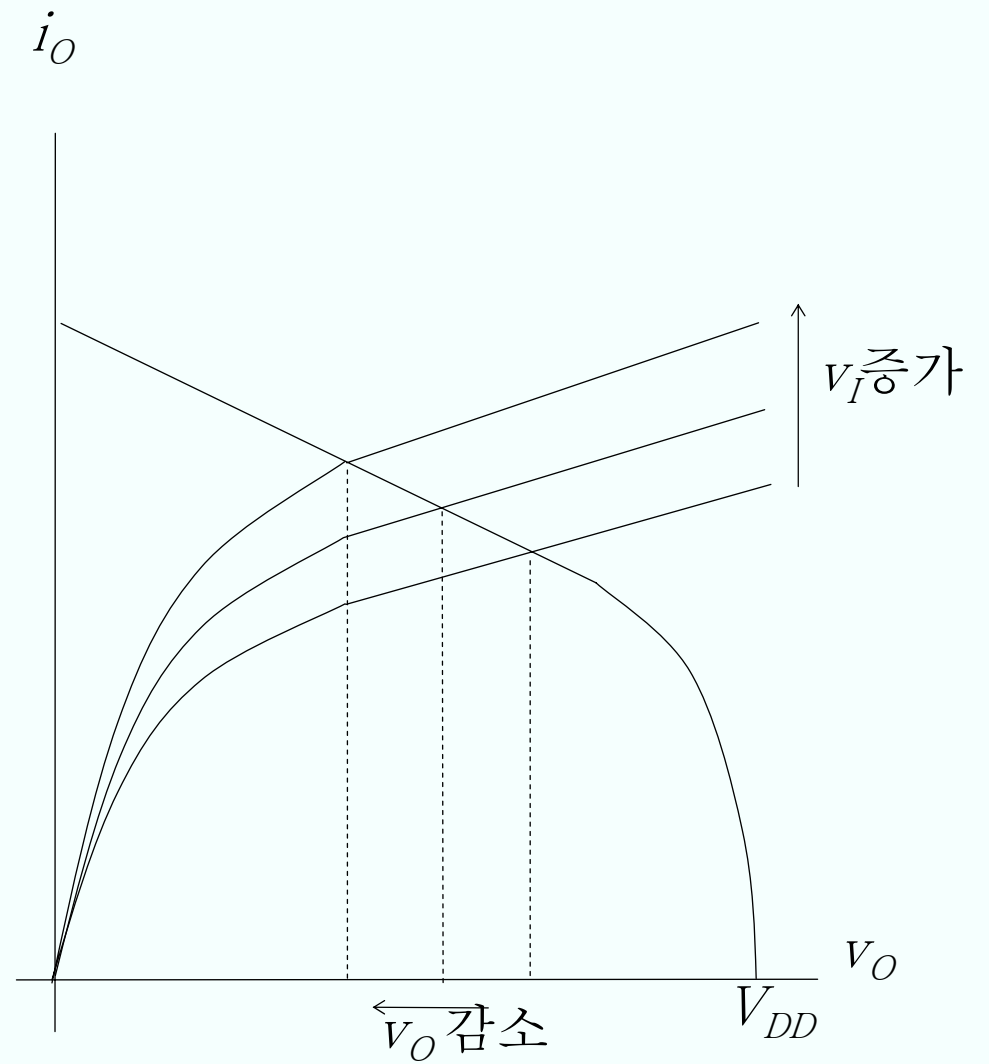
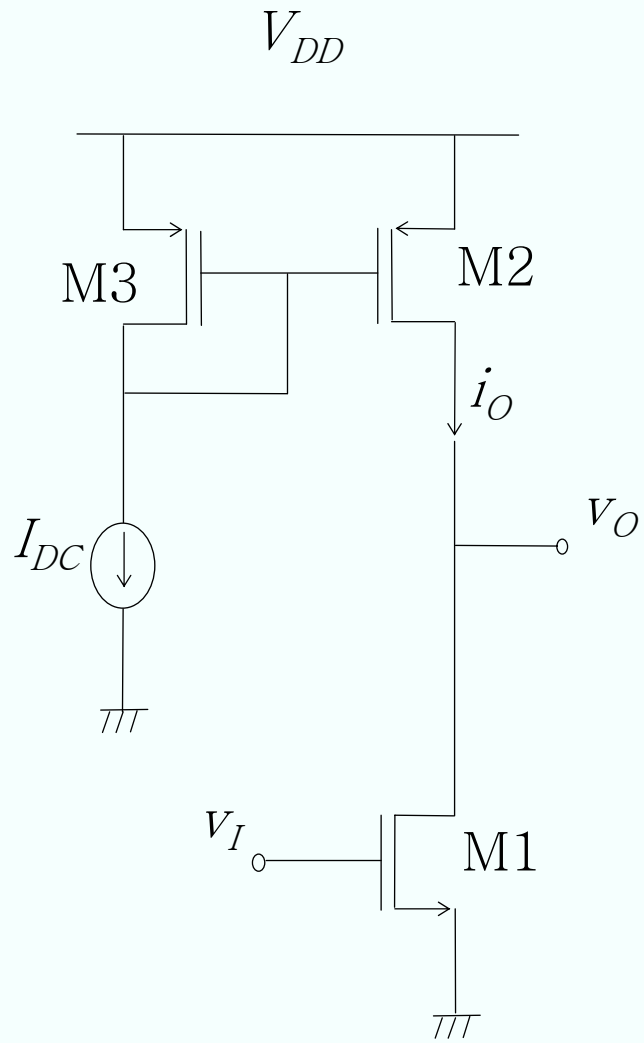

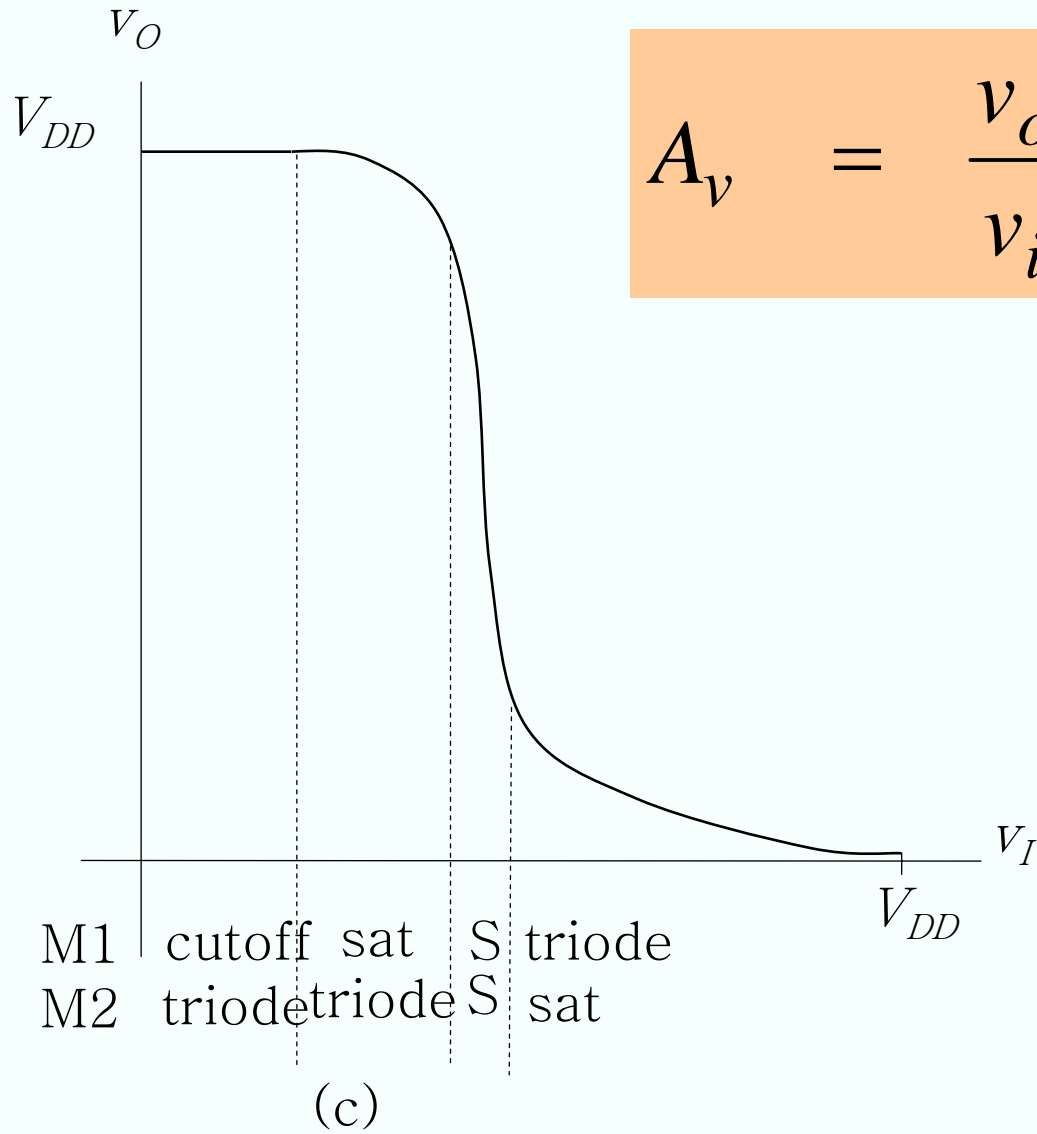

$$A_v = \frac{v_o}{v_i} = -g_{m1} \cdot (r_{o1} \parallel r_{o2})$$

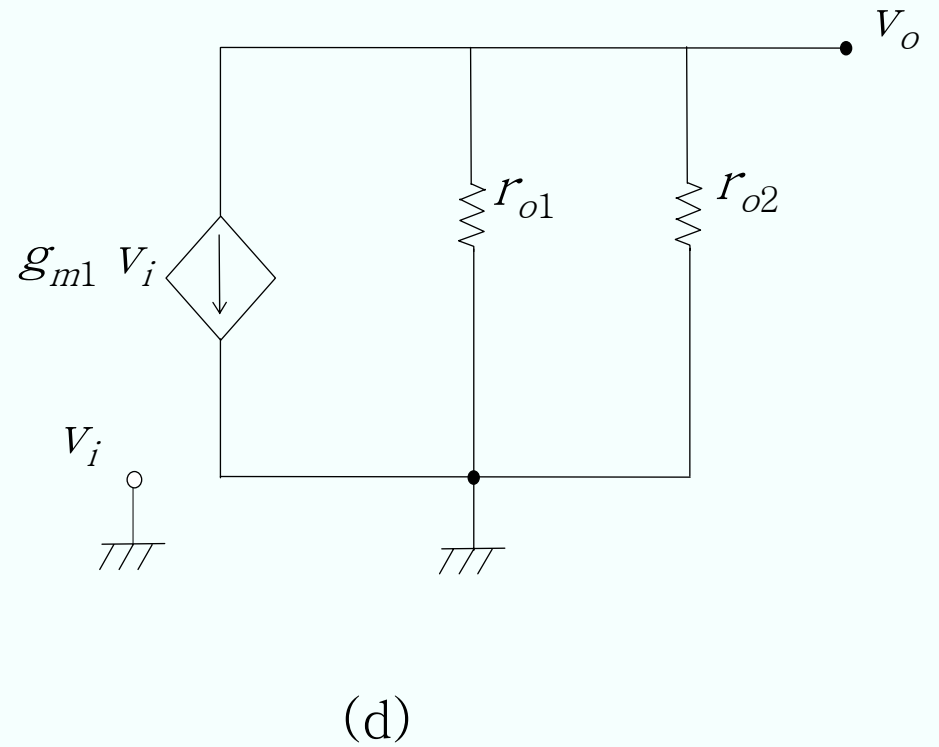

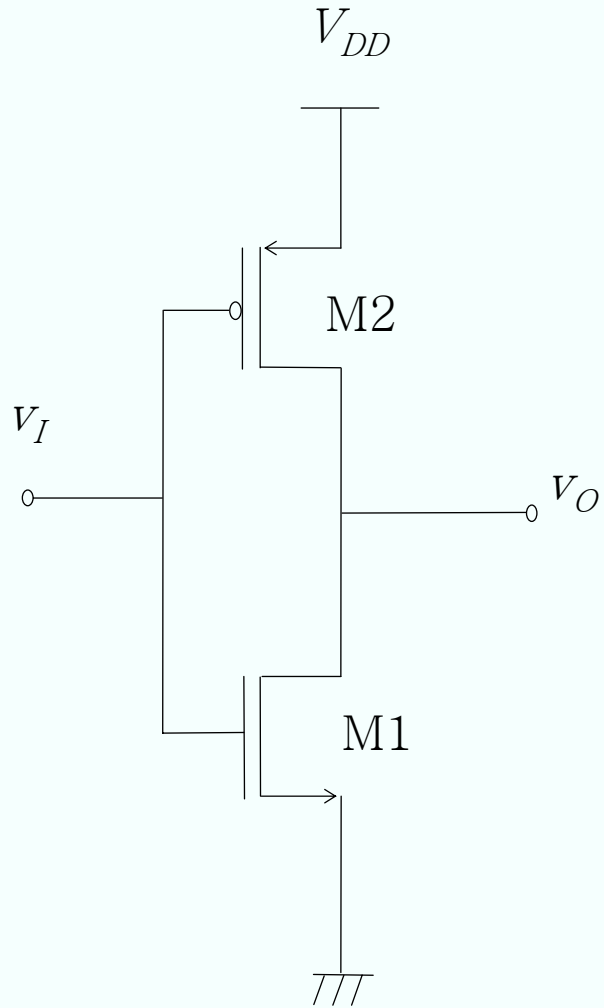

(a)

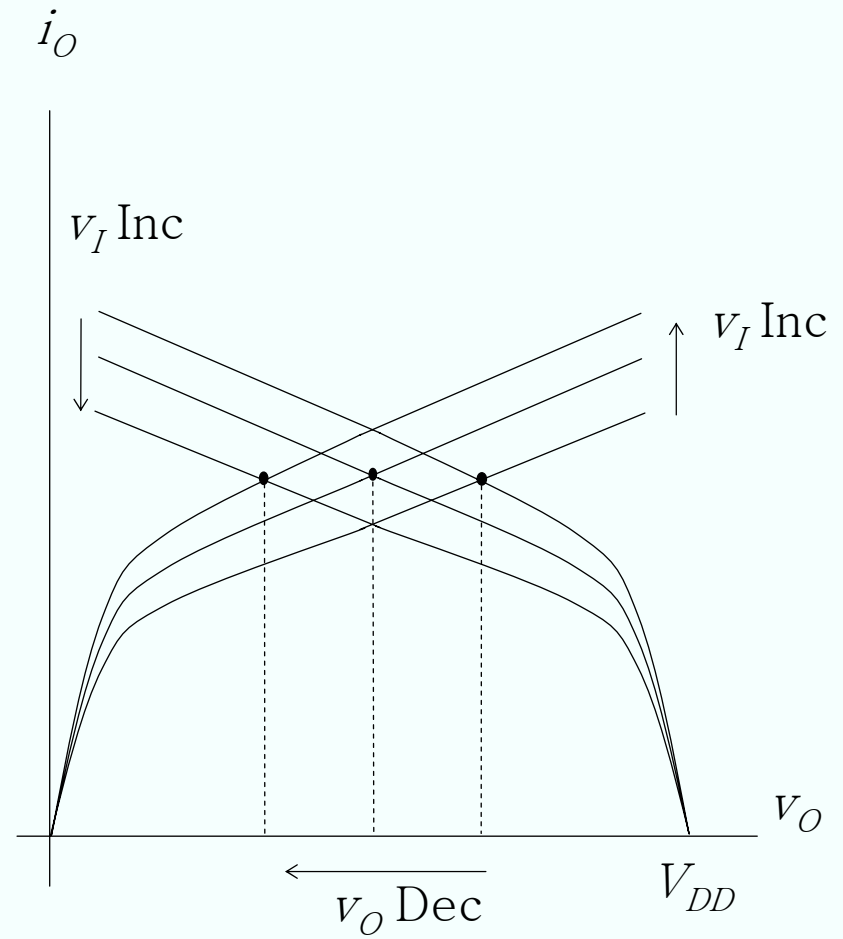

(b)

$$A_v = \frac{v_o}{v_i} = - (g_{m1} + g_{m2}) \cdot (r_{o1} \parallel r_{o2})$$

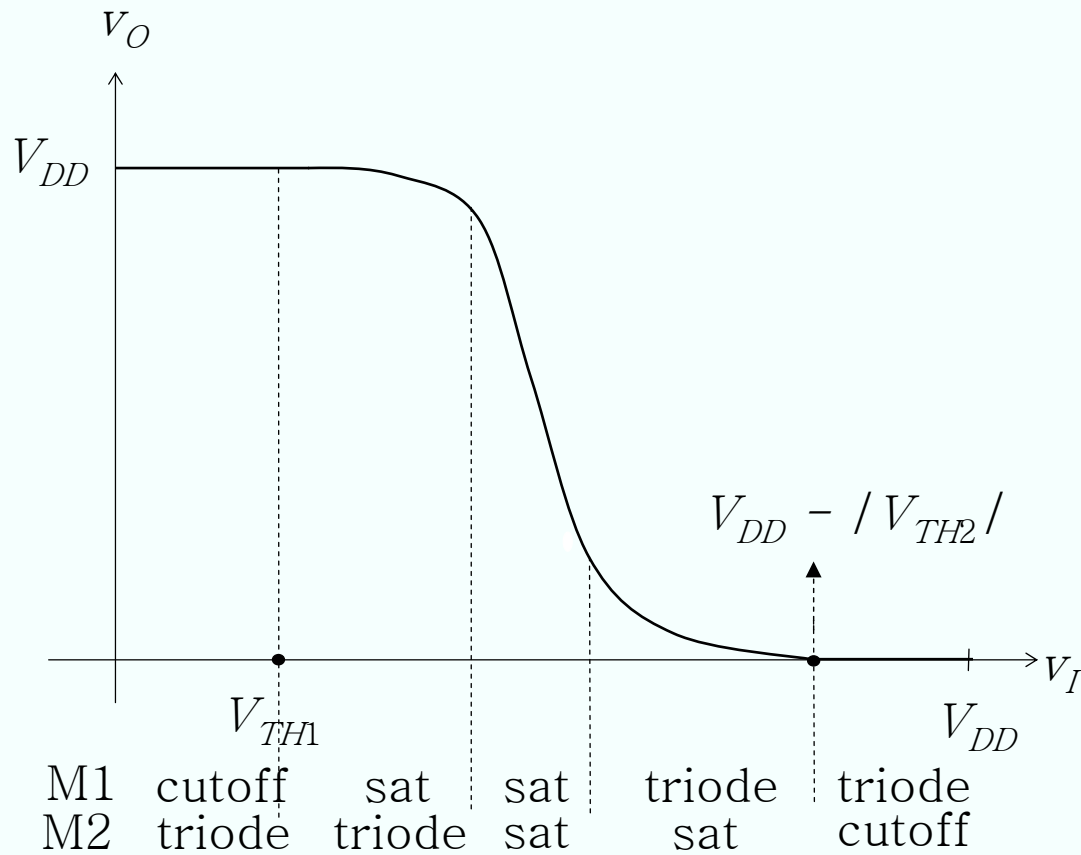

(c)

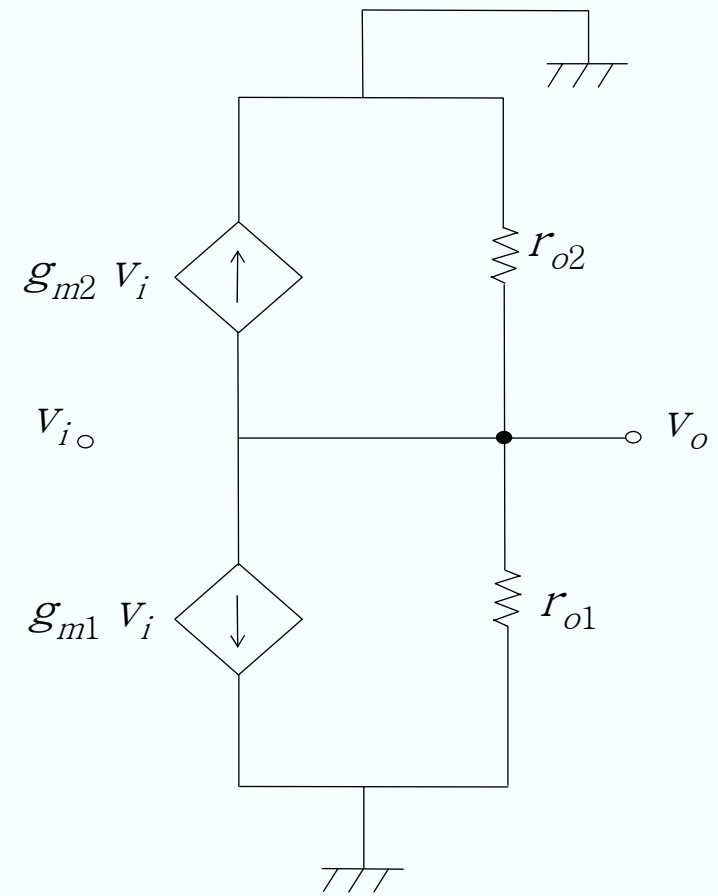

(d)



## 4.3 Common gate amplifier

Input port: S – G

Output port: D – G

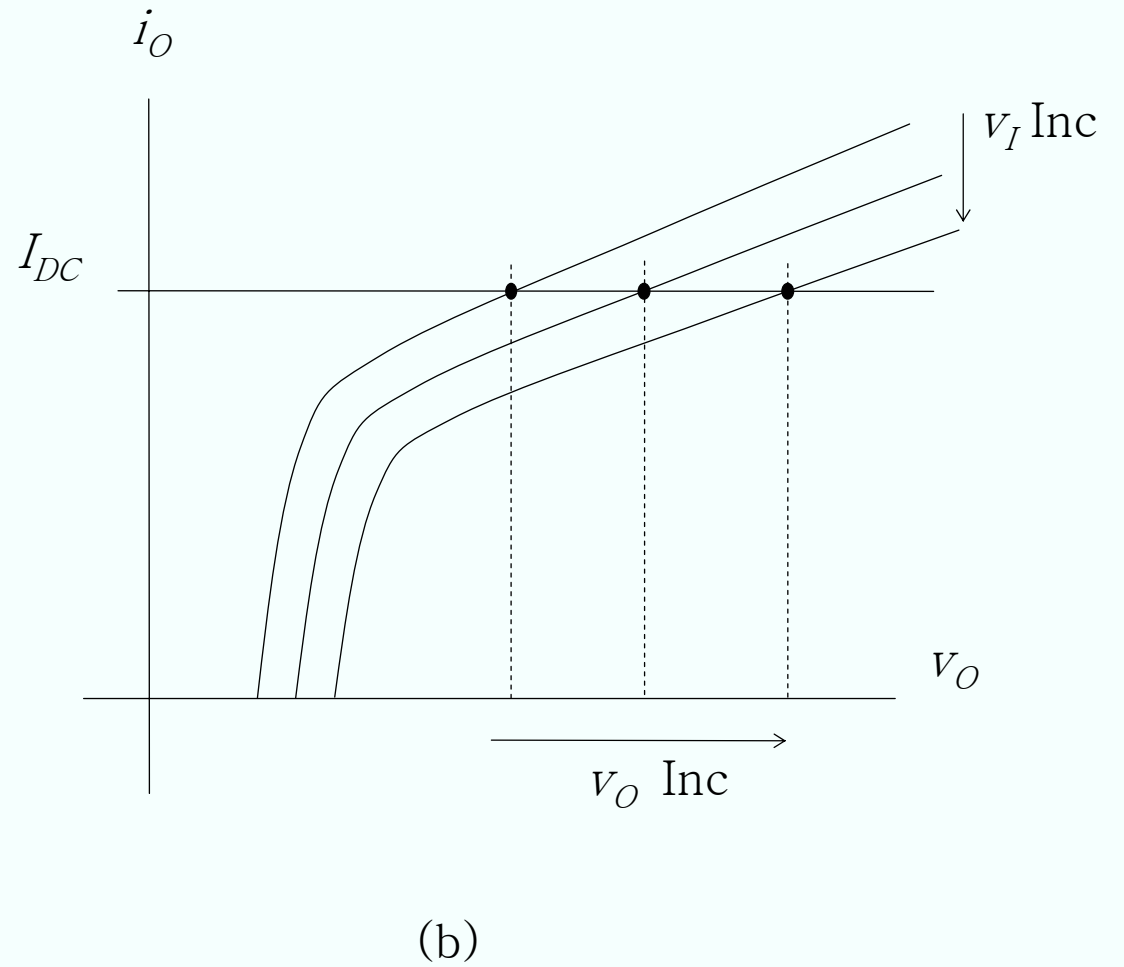
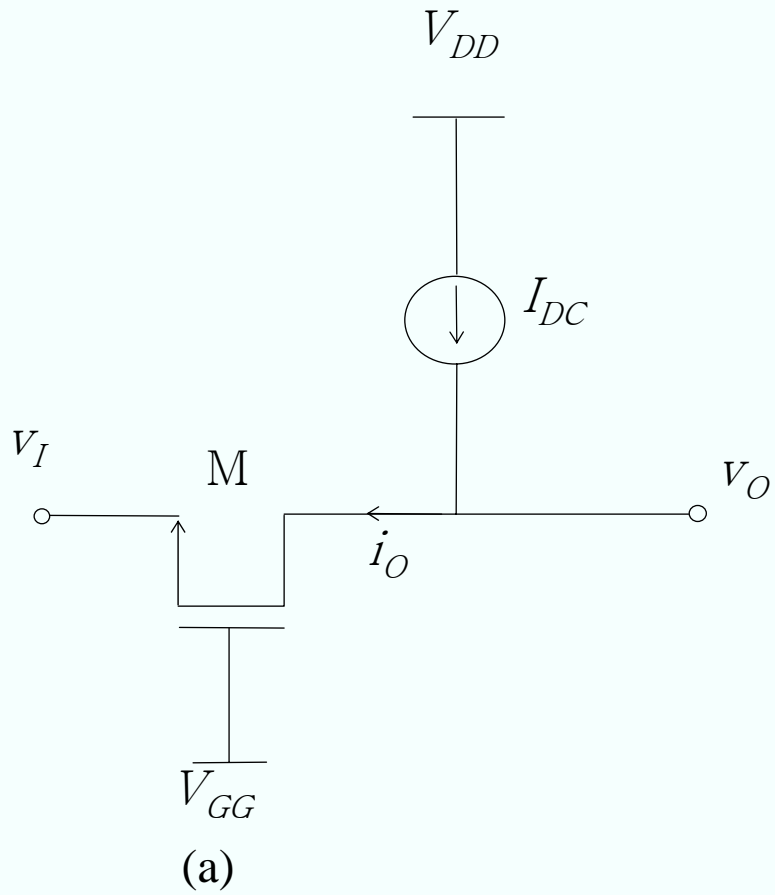

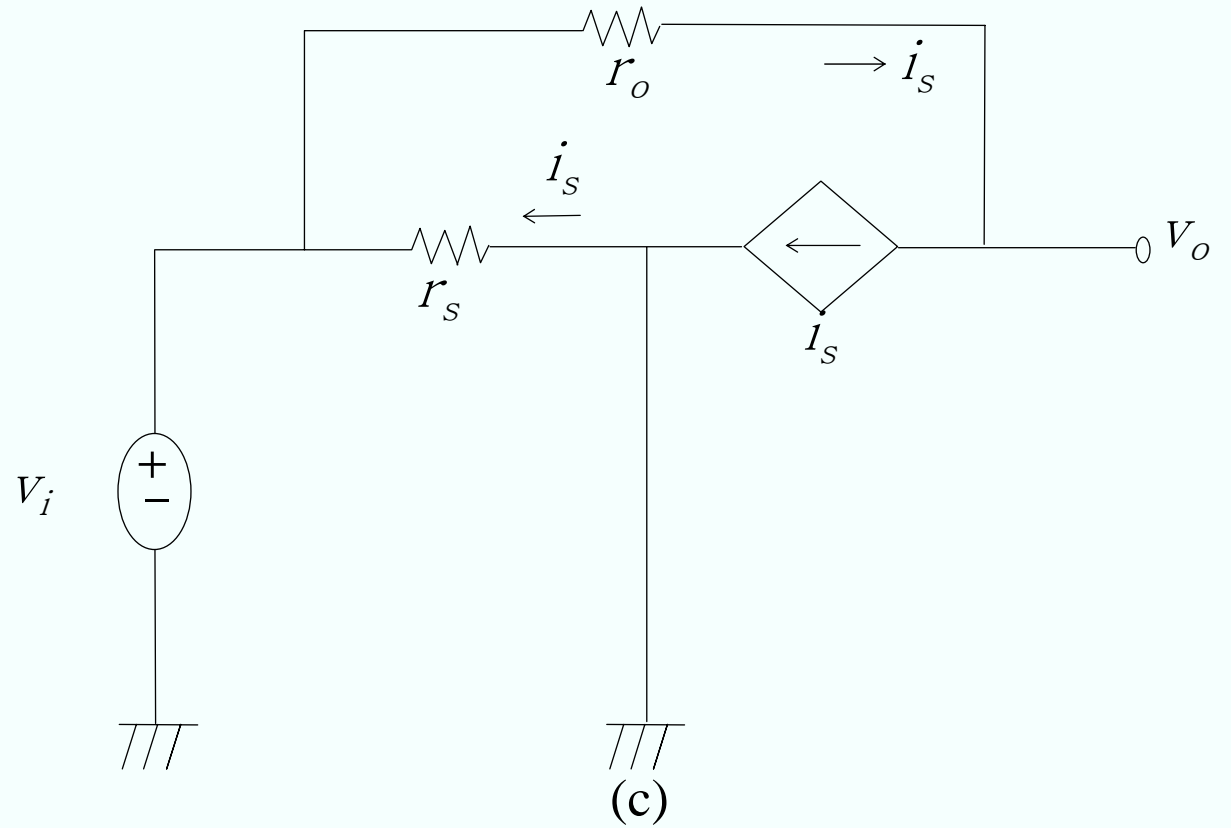
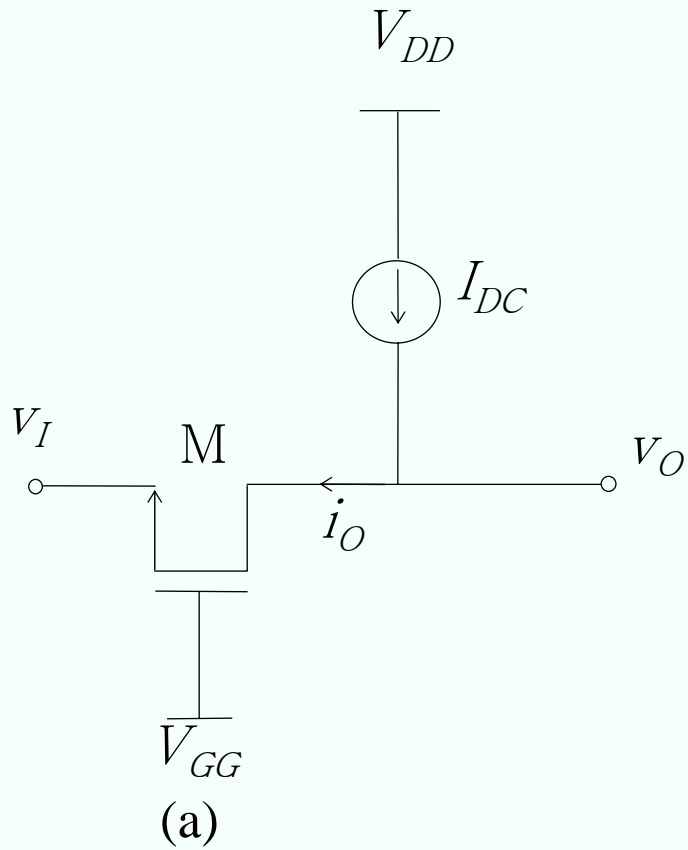

$$i_s = -\frac{v_i}{r_s} = -g_m \cdot v_i$$

$$v_o = -i_s \cdot r_o + v_i = (g_m r_o + 1) \cdot v_i$$

$$A_v \triangleq \frac{v_o}{v_i} = (g_m r_o + 1)$$

Ri = infinity

Body effect neglected

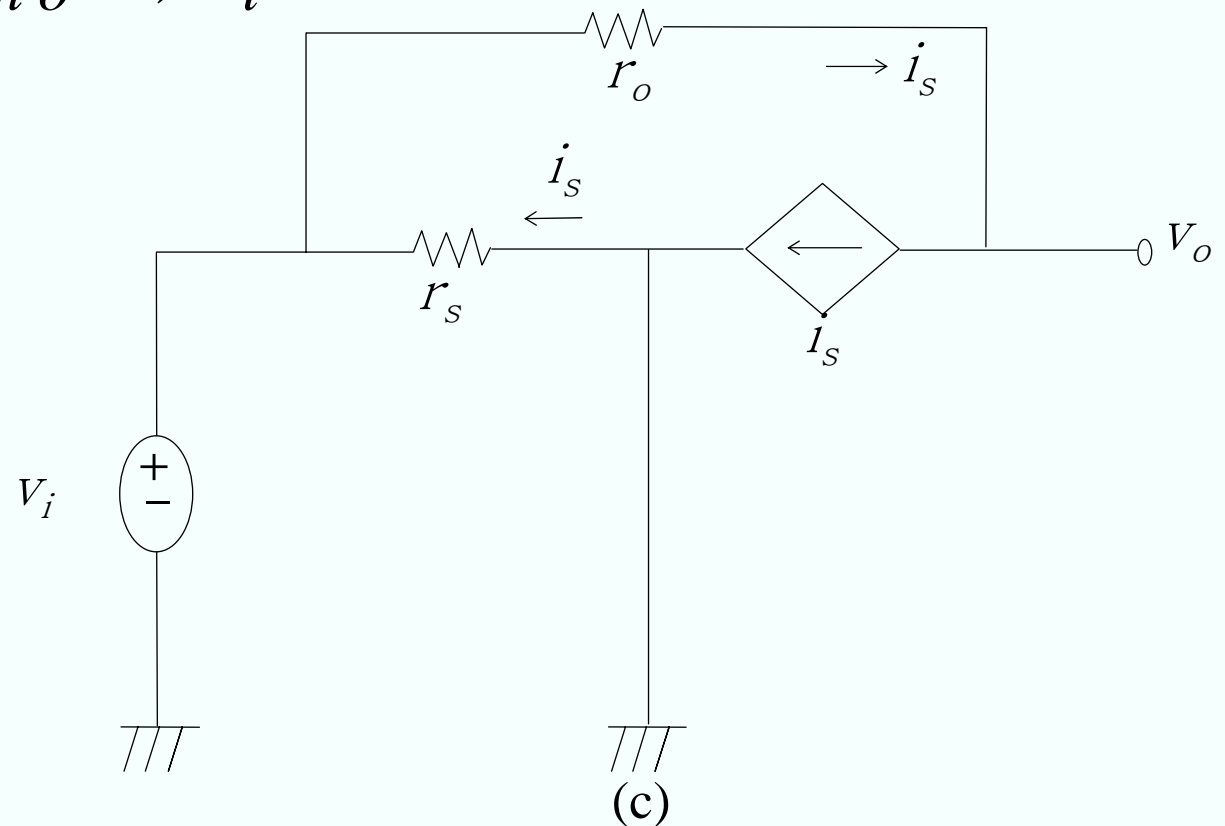

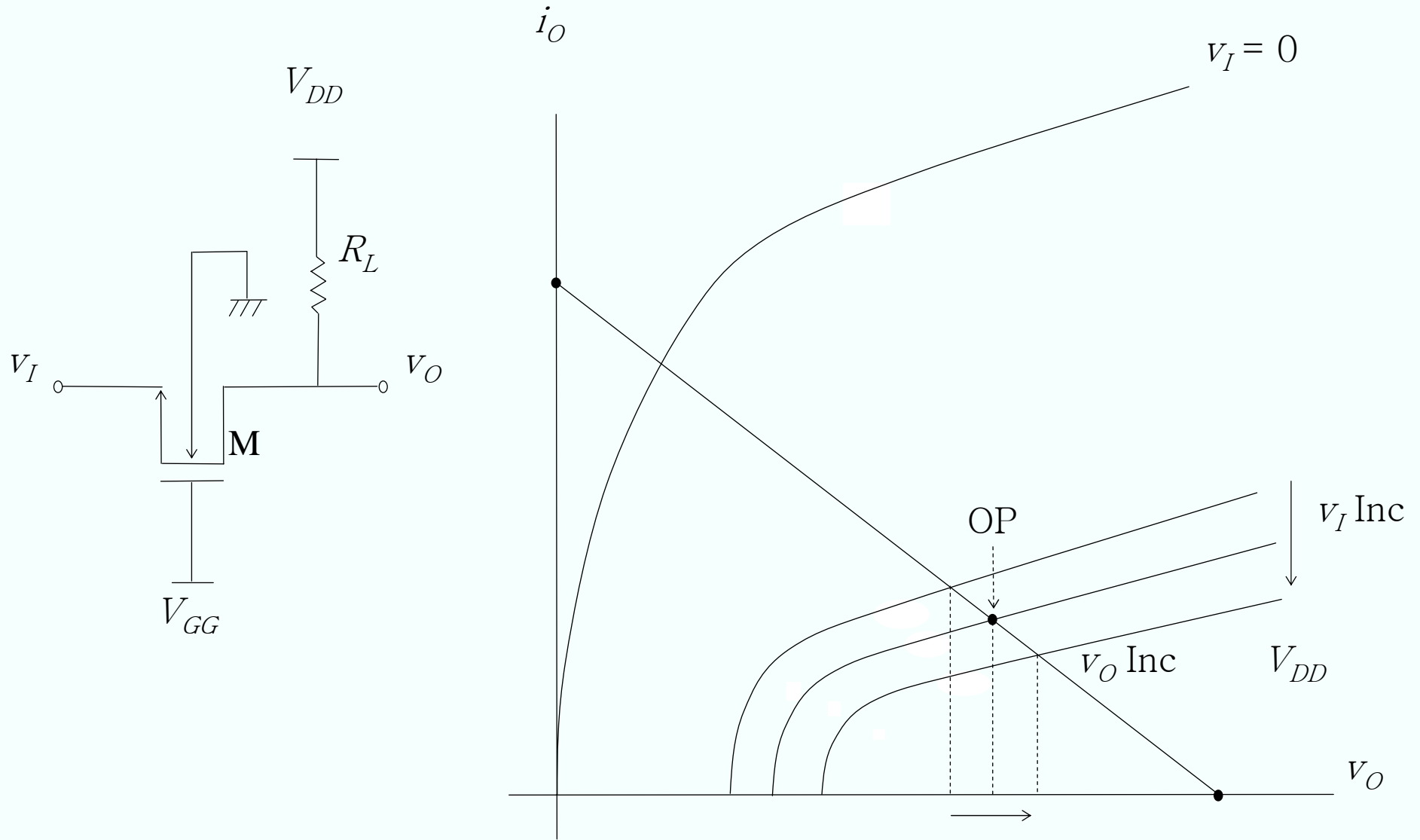

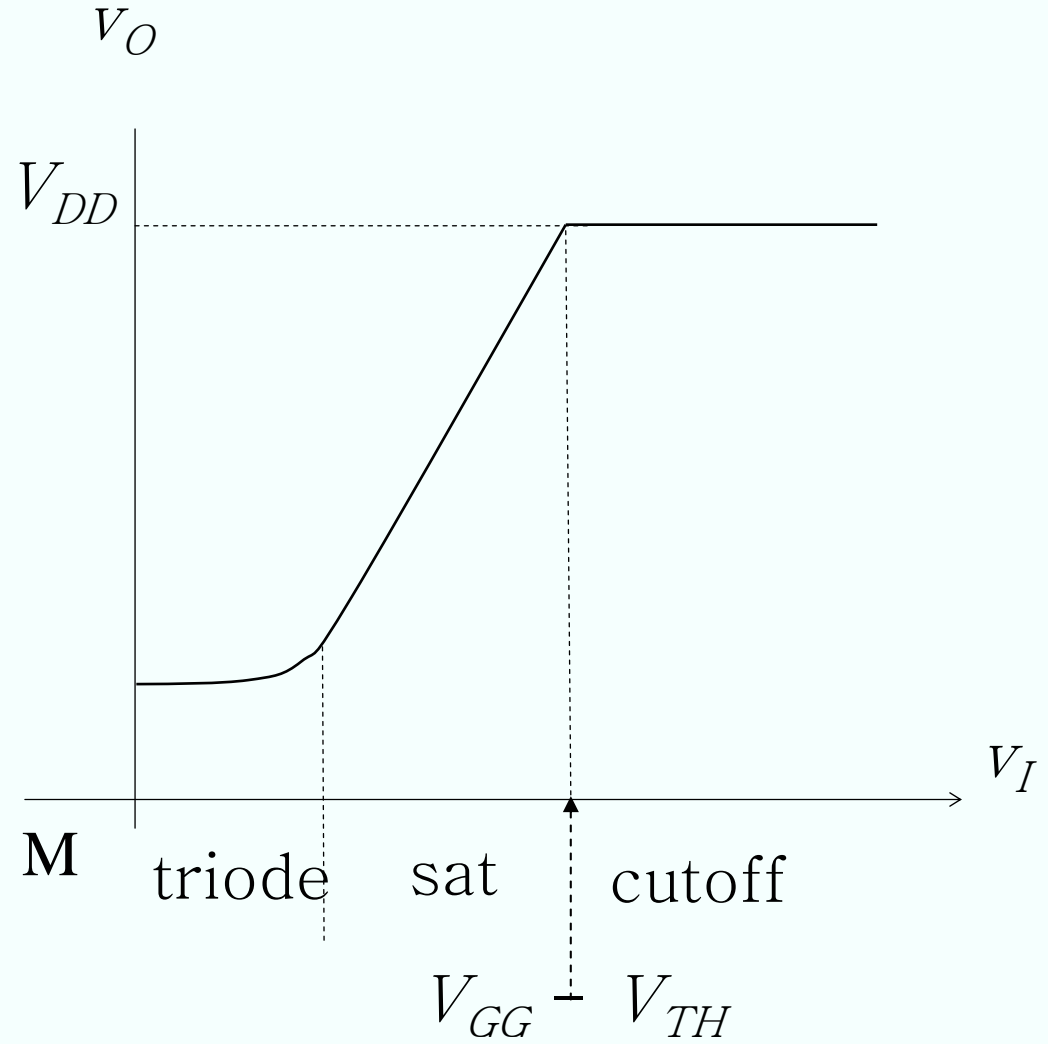
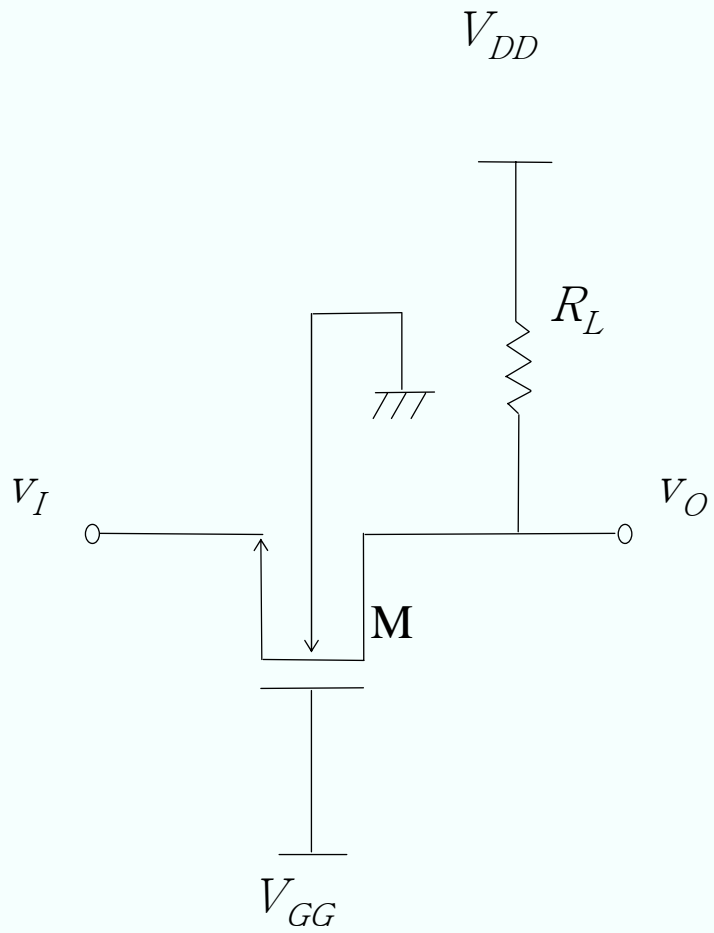



$$v_{gs} = -v_i$$

$$|v_i| < 0.2 \cdot (V_{GS} - V_{TH}) = 0.2 \cdot (V_{GG} - V_I - V_{TH})$$

For distortion < 10%  
Larger than CS amp

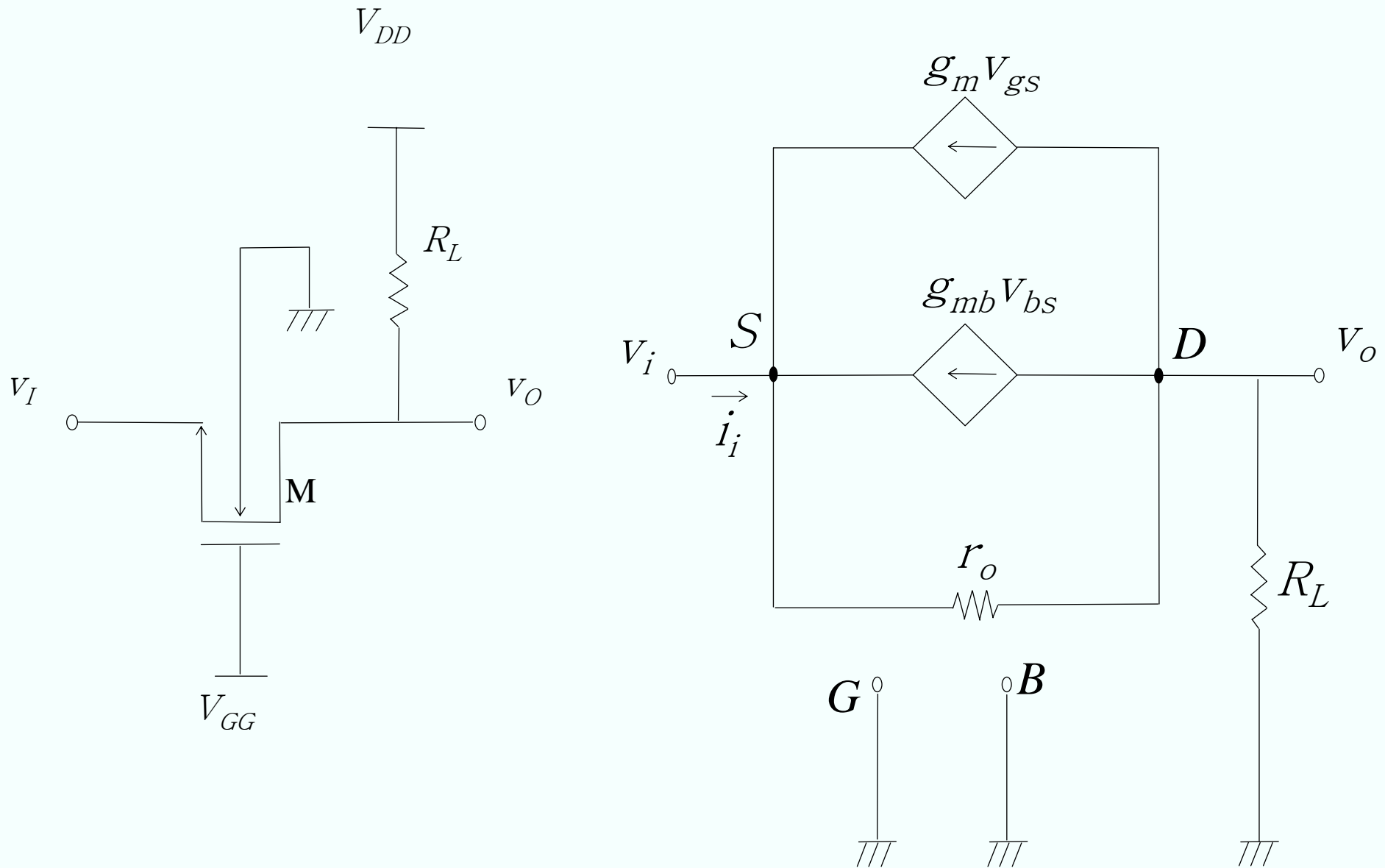

$$A_v \triangleq \frac{v_o}{v_i}$$

$$= + \left( g_m + g_{mb} + \frac{1}{r_o} \right) \cdot (r_o \parallel R_L)$$

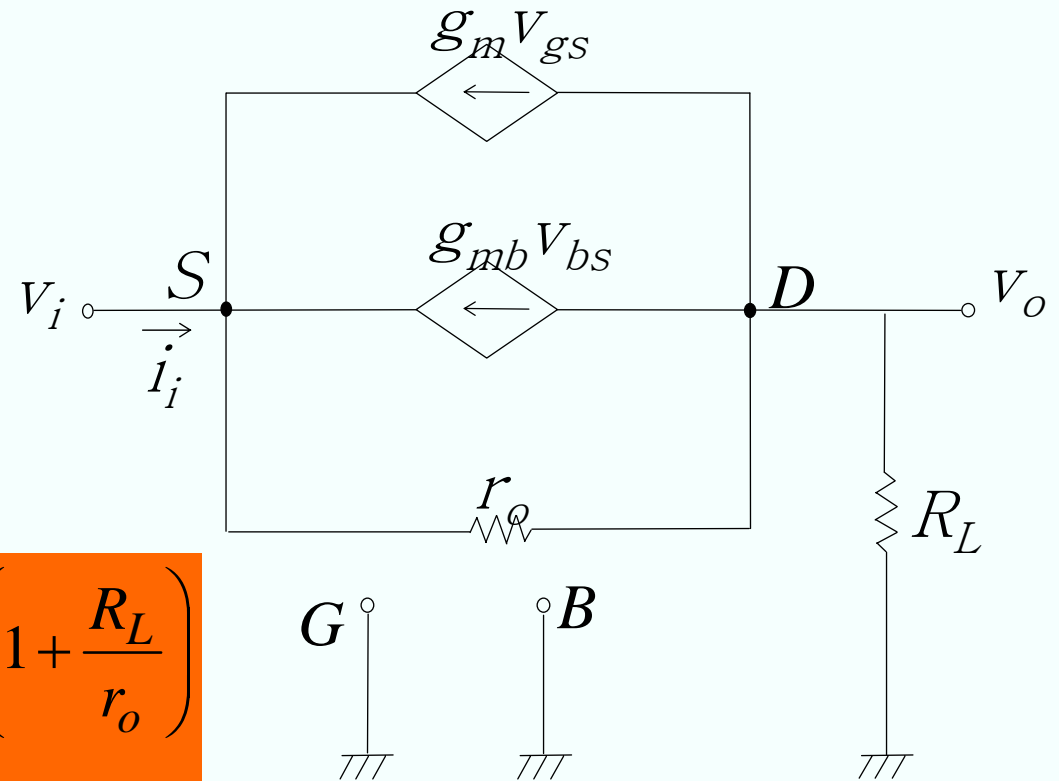

$$R_i \triangleq \frac{v_i}{i_i} = \frac{1}{g_m + g_{mb} + \frac{1}{r_o}} \cdot \left( 1 + \frac{R_L}{r_o} \right)$$



$$\begin{aligned}\frac{V_i}{i_i} &= \frac{V_i}{(g_m + g_{mb}) \cdot V_i + \frac{(1 - A_v)V_i}{r_o}} \\ &= \frac{1}{g_m + g_{mb} + \frac{1 - (g_m + g_{mb})R_L}{r_o + R_L}} \\ &= \frac{r_o + R_L}{(g_m + g_{mb})(r_o + R_L) + 1 - (g_m + g_{mb})R_L} \\ &= \frac{r_o + R_L}{(g_m + g_{mb}) \cdot r_o + 1} \\ &= \frac{1}{\left(g_m + g_{mb} + \frac{1}{r_o}\right)} \cdot \left(1 + \frac{R_L}{r_o}\right)\end{aligned}$$

Change of input resistance  $R_i$  with  $R_L$ 

$R_L$	$R_i$
0	$\frac{1}{g_m + g_{mb}}$
$r_o$	$\frac{2}{g_m + g_{mb}}$
$g_m r_o \cdot r_o$	$\frac{(g_m r_o + 1)}{g_m + g_{mb}} \approx r_o$
$\infty$	$\infty$



R load CG amp with Rs

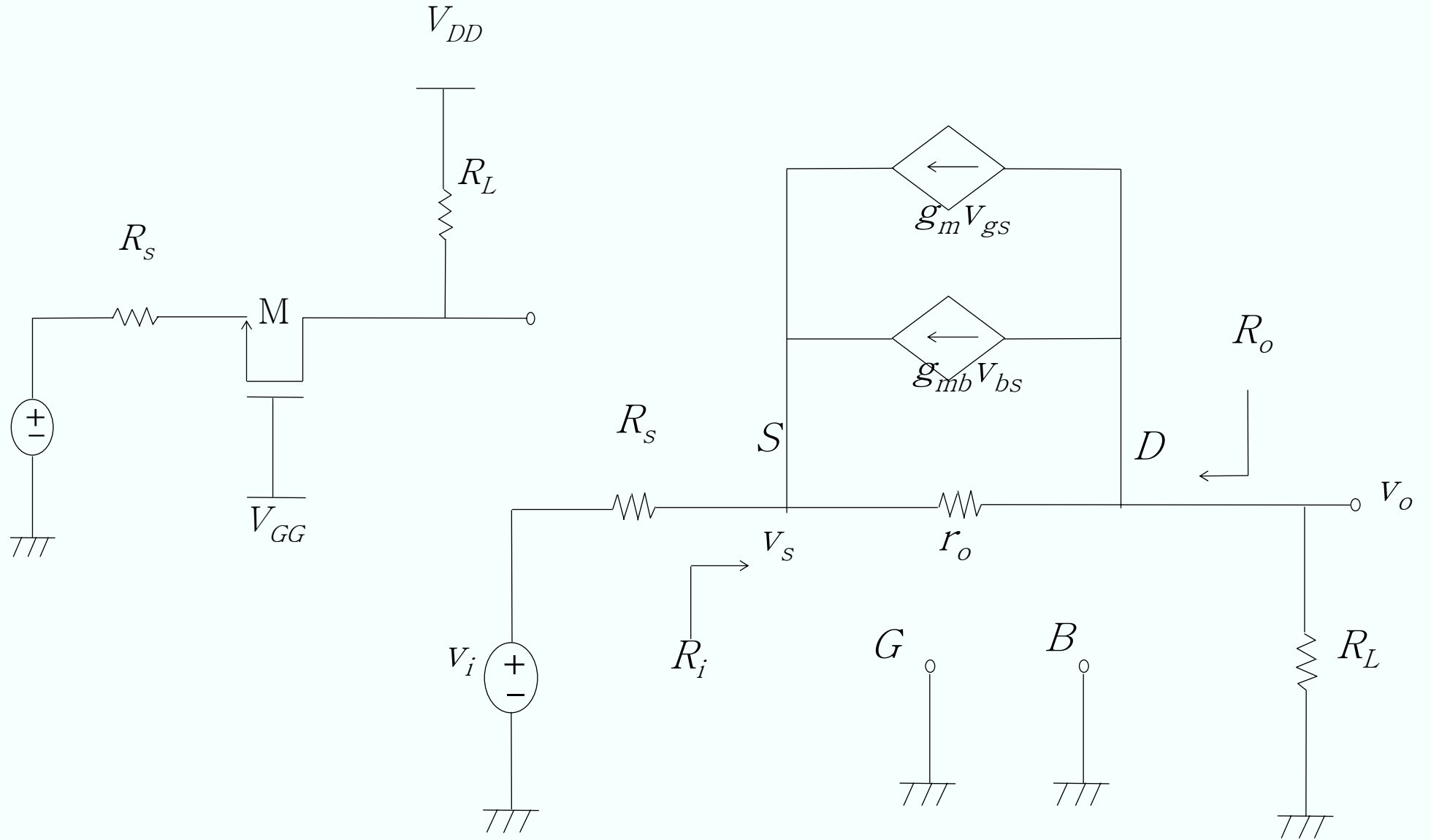

$$A_v \triangleq \frac{v_o}{v_i} = \frac{R_i}{R_s + R_i} \cdot \left( g_m + g_{mb} + \frac{1}{r_o} \right) \cdot (r_o \parallel R_L)$$

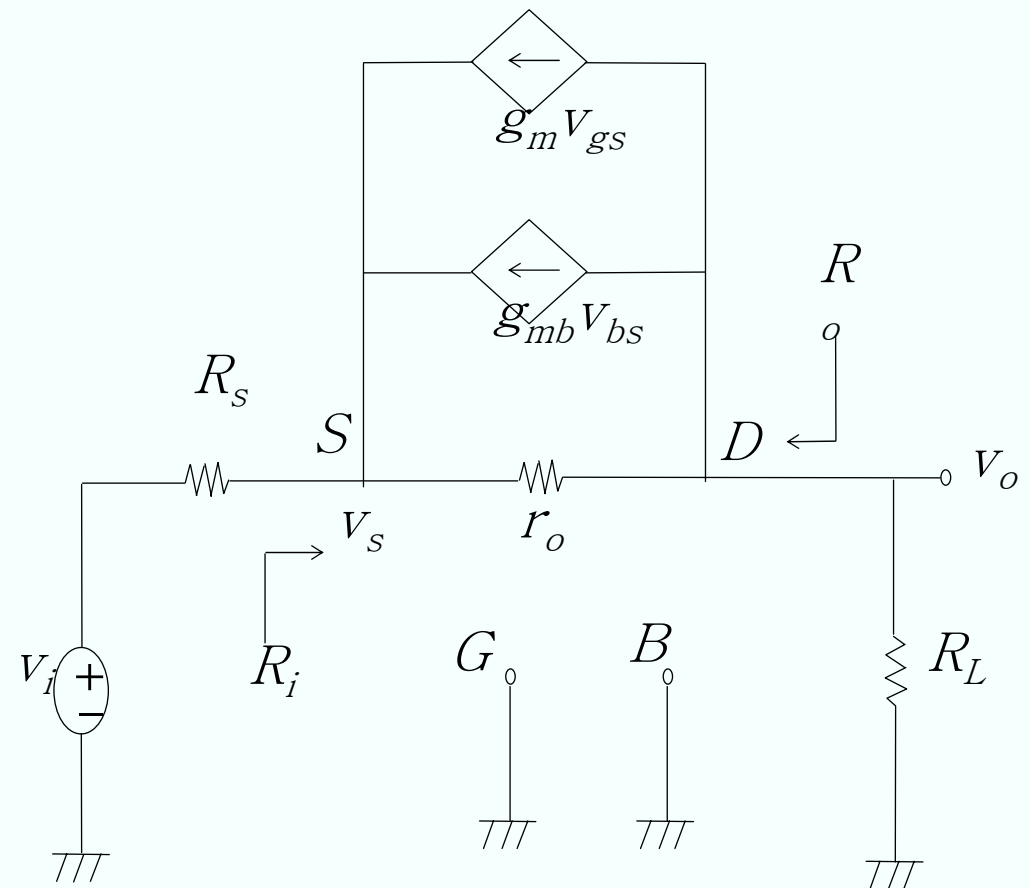



$$v_s = R_s \cdot i_x \quad i_x = g_m v_{gs} + g_{mb} v_{bs} + \frac{v_x - v_s}{r_o}$$

$$v_{gs} = v_{bs} = -v_s = -R_s \cdot i_x$$

$$R_o \triangleq \frac{v_x}{i_x} = r_o + R_s + (g_m + g_{mb})r_o \cdot R_s$$

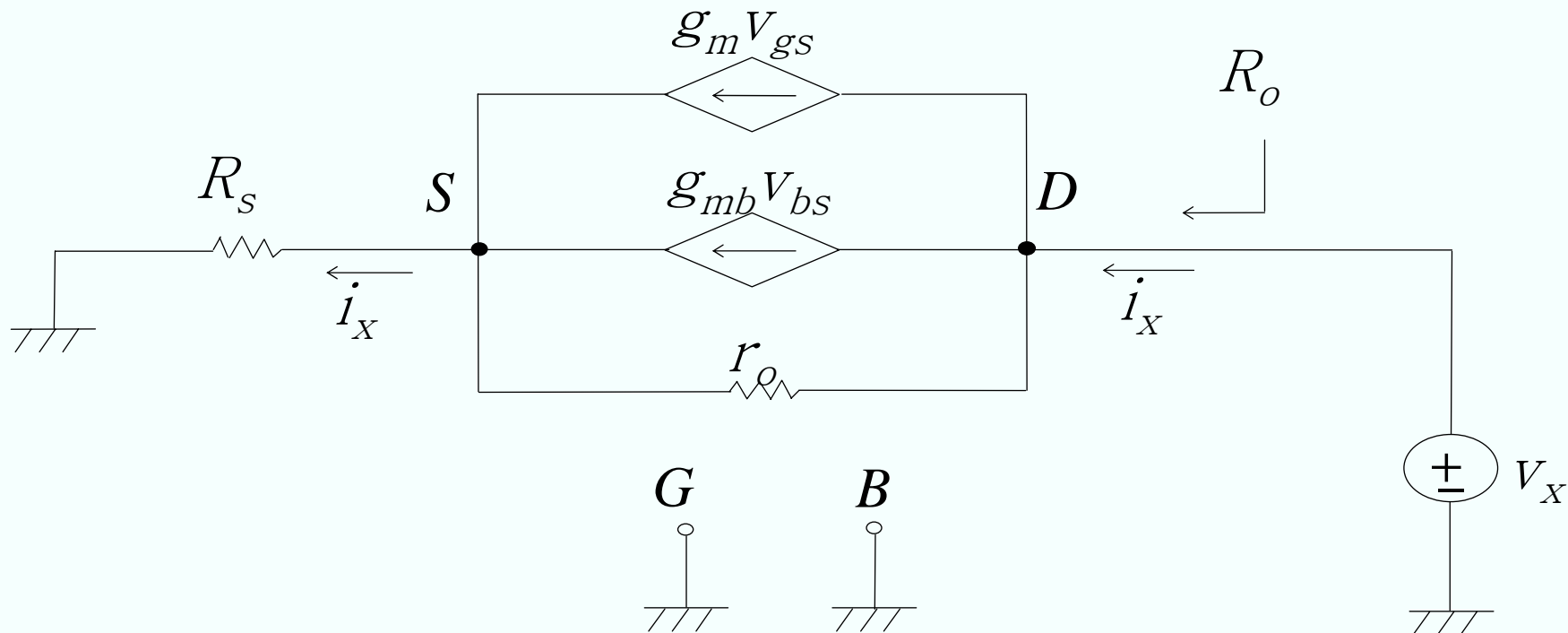



## 4.4 Common drain amplifier

Input ports: G – D

Output ports: S – D

Output(S) voltage follows Input(G) voltage

=> Source Follower

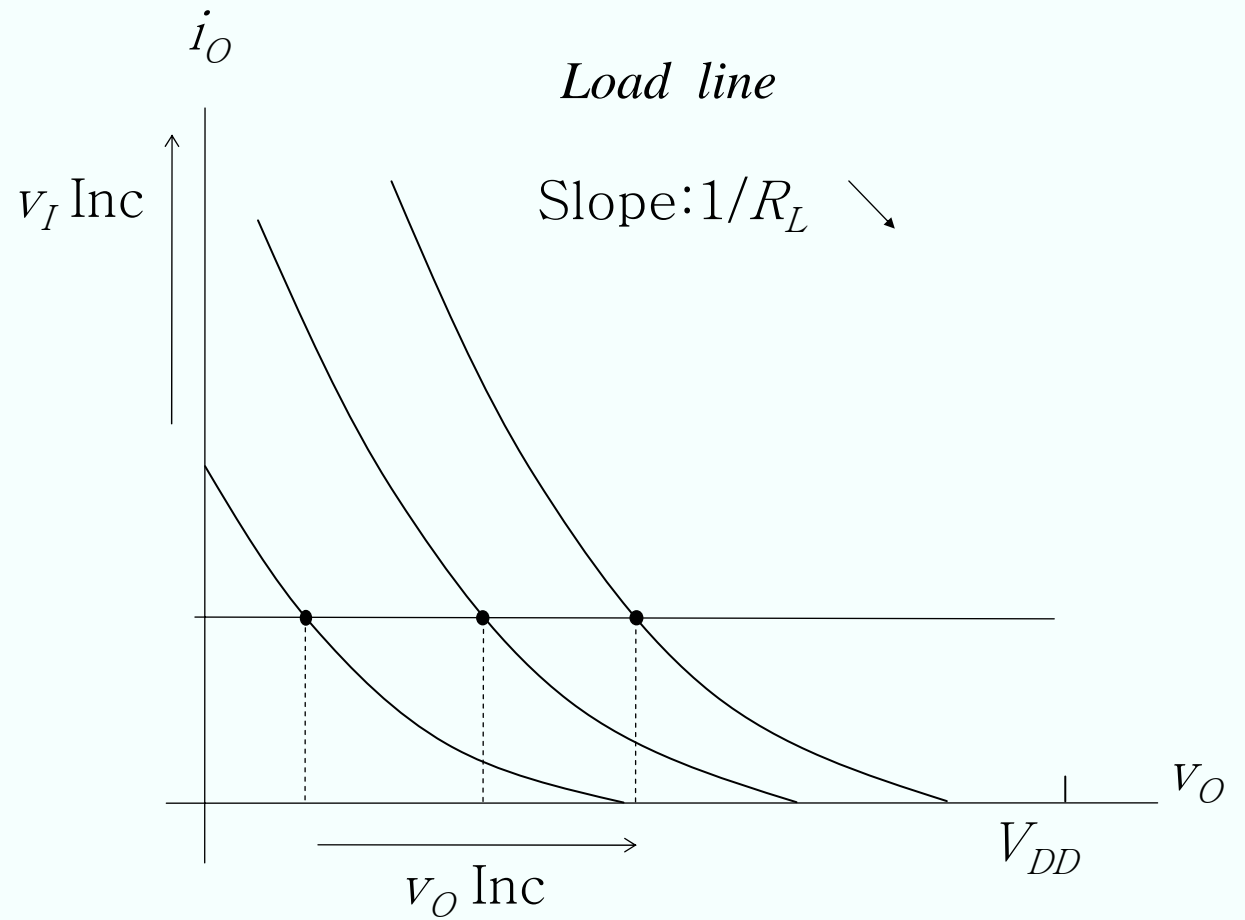
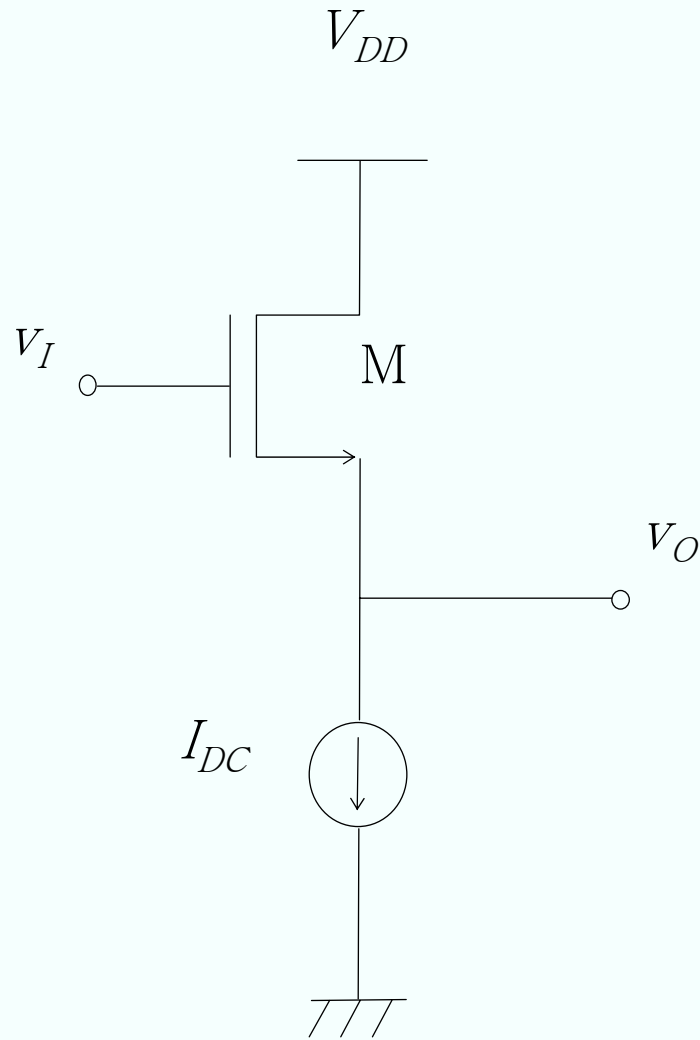

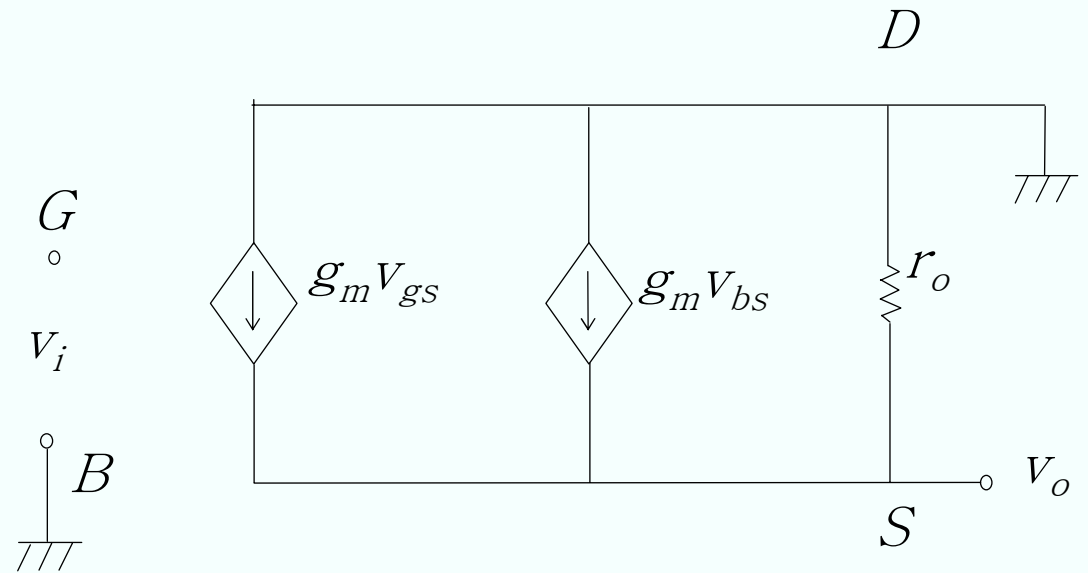
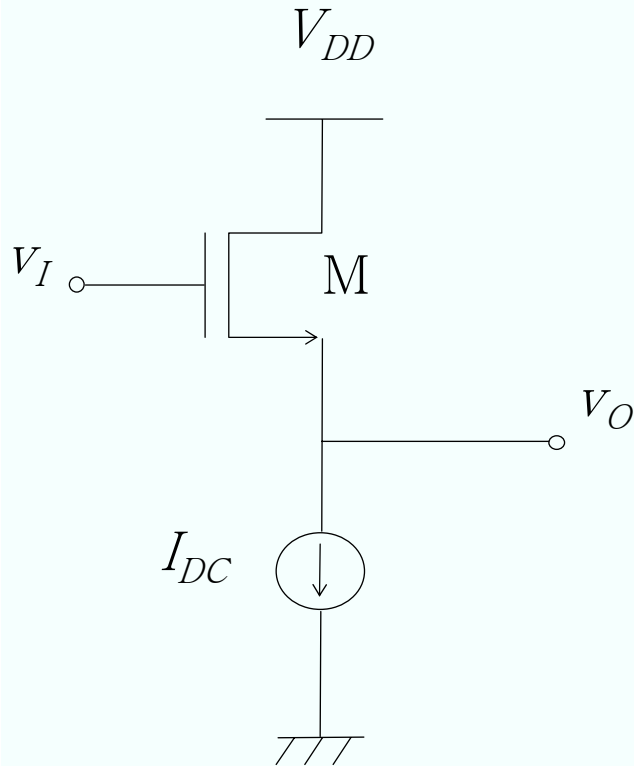

$$v_{gs} = v_i - v_o \quad v_{bs} = -v_o$$

$$A_v = \frac{v_o}{v_i} = \frac{g_m}{g_m + g_{mb} + \frac{1}{r_o}} \approx \frac{g_m}{g_m + g_{mb}} < 1$$

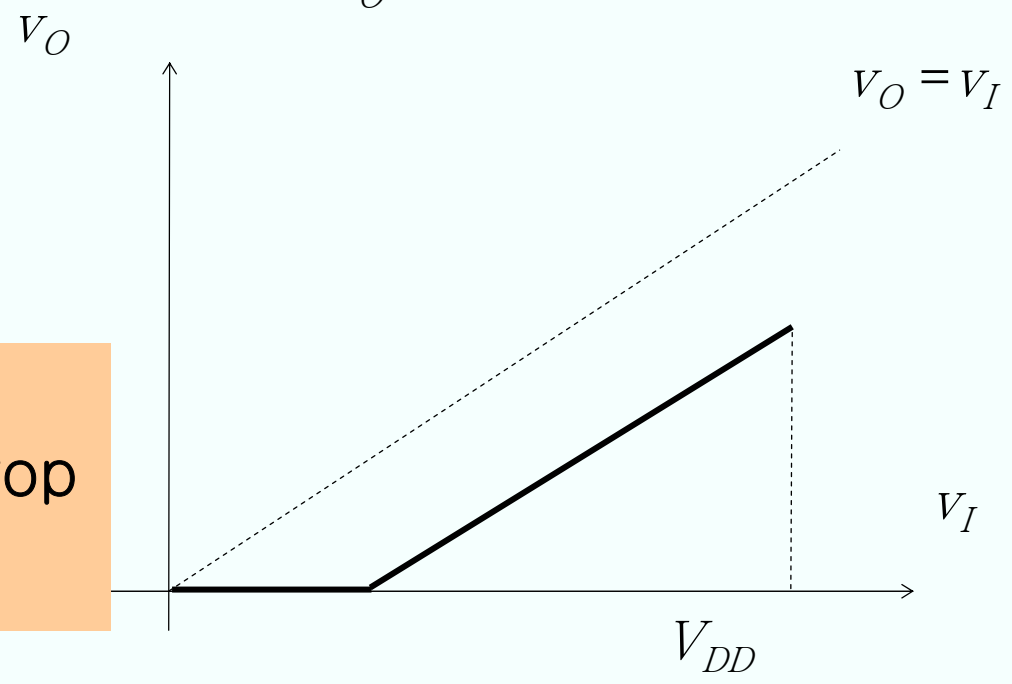
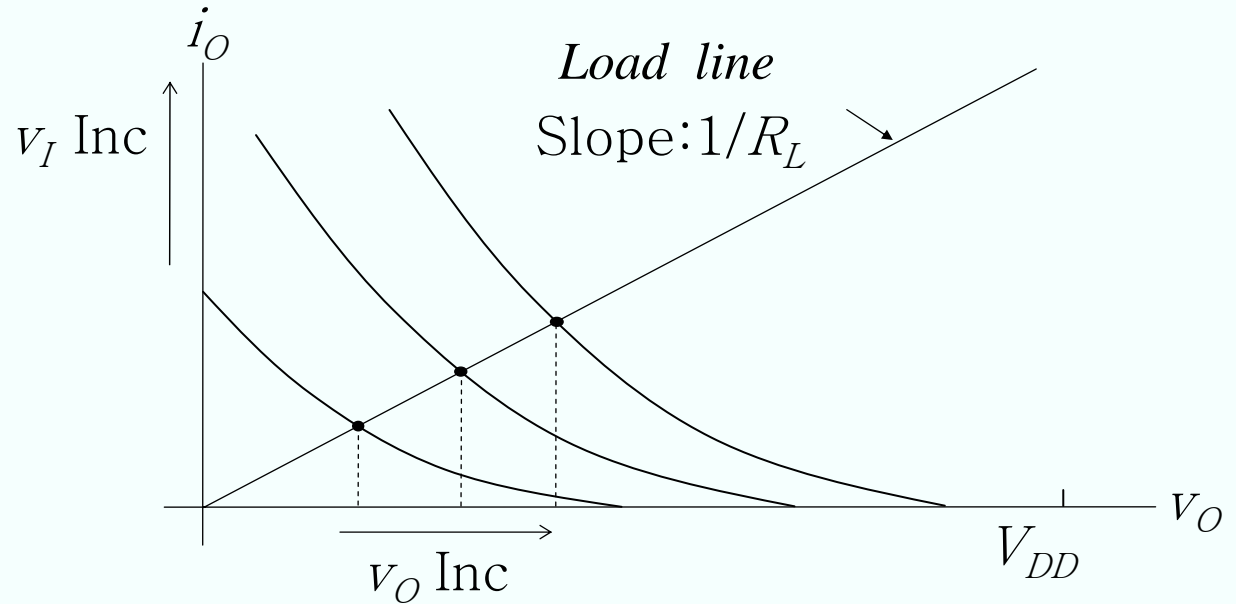
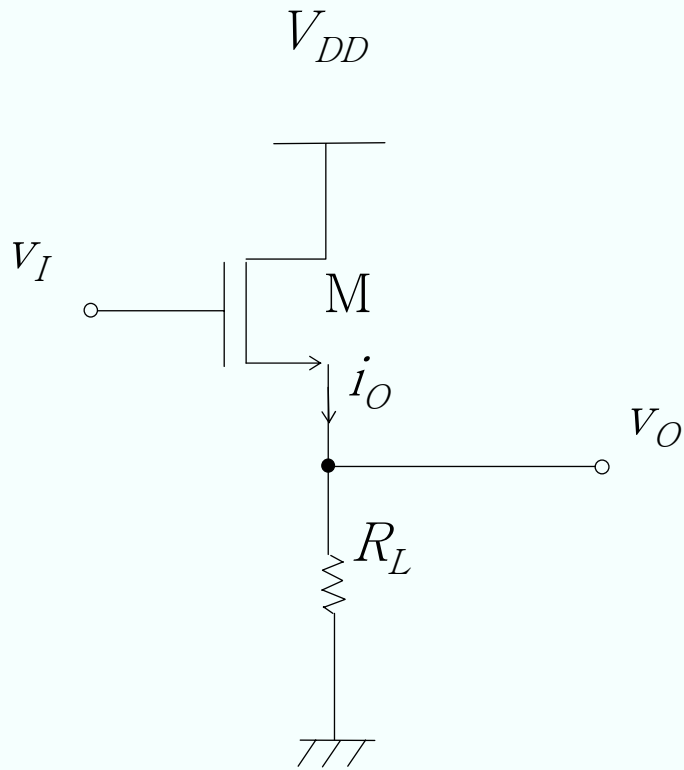

Vo head room reduced significantly due to VGS drop  
 $(V_o = V_i - V_{GS})$

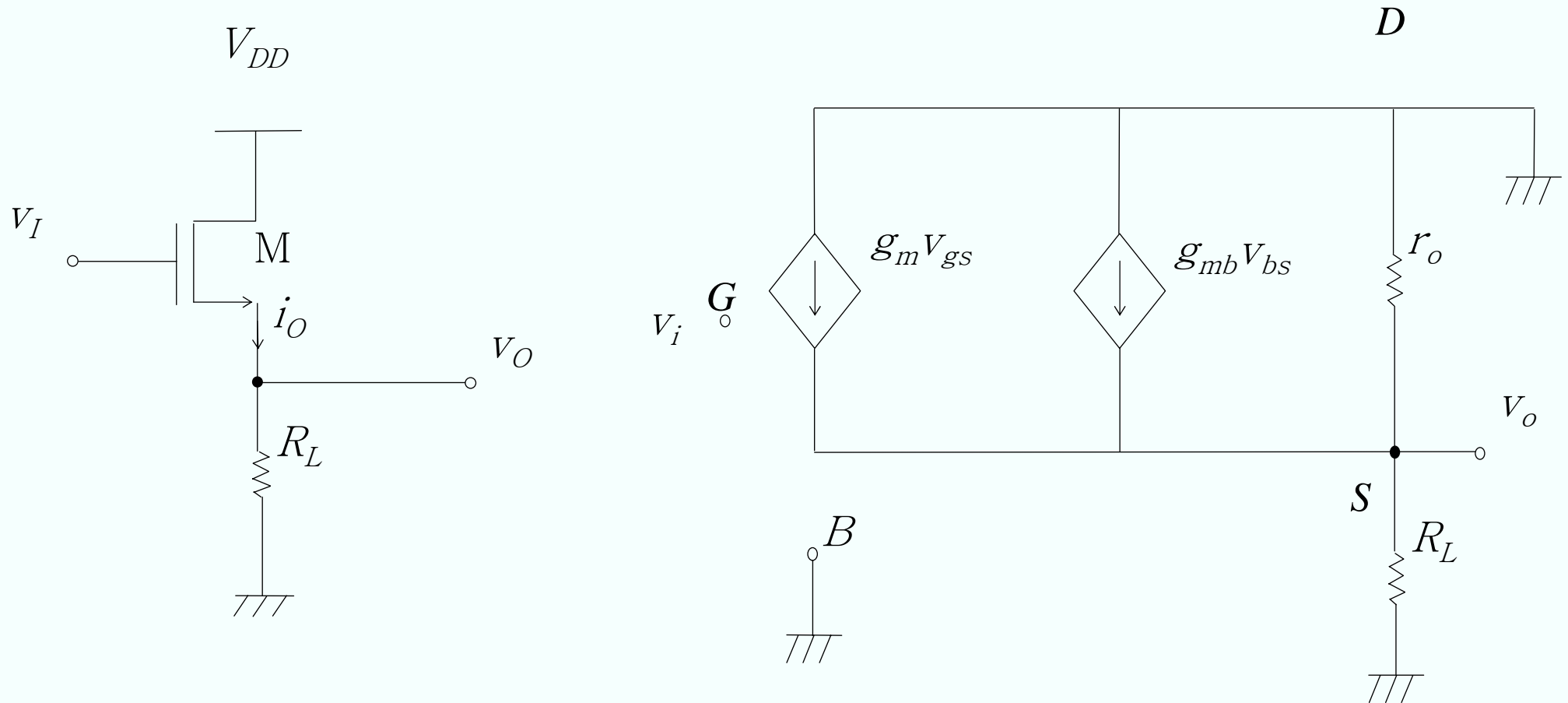

$$A_v = \frac{g_m}{g_m + g_{mb} + \left( \frac{1}{r_o \parallel R_L} \right)}$$

Non-linearity due to body effect

$$A_v = \frac{g_m}{g_m + g_{mb} + \left( \frac{1}{r_o \parallel R_L} \right)}$$

$$v_{gs} = v_i - v_o = (1 - A_v) \cdot v_i$$

$$= \frac{g_{mb} + \frac{1}{r_o \parallel R_L}}{g_m + g_{mb} + \frac{1}{r_o \parallel R_L}} \cdot v_i$$

$$\approx \frac{g_{mb}}{g_m + g_{mb}} \cdot v_i$$

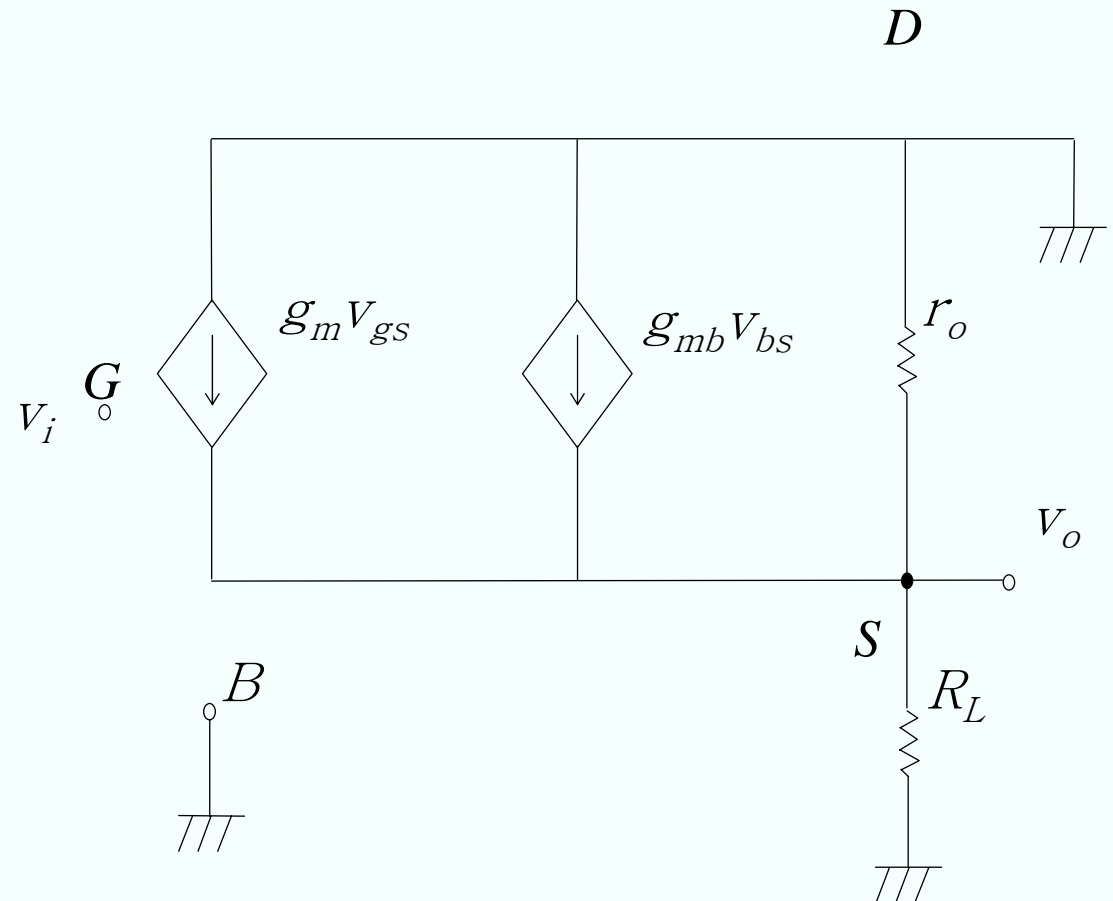

$$|v_i| < 0.2(V_{GS} - V_{TH}) \cdot \frac{g_m + g_{mb}}{g_{mb}}$$

For distortion < 10%  
Larger than CG, CS

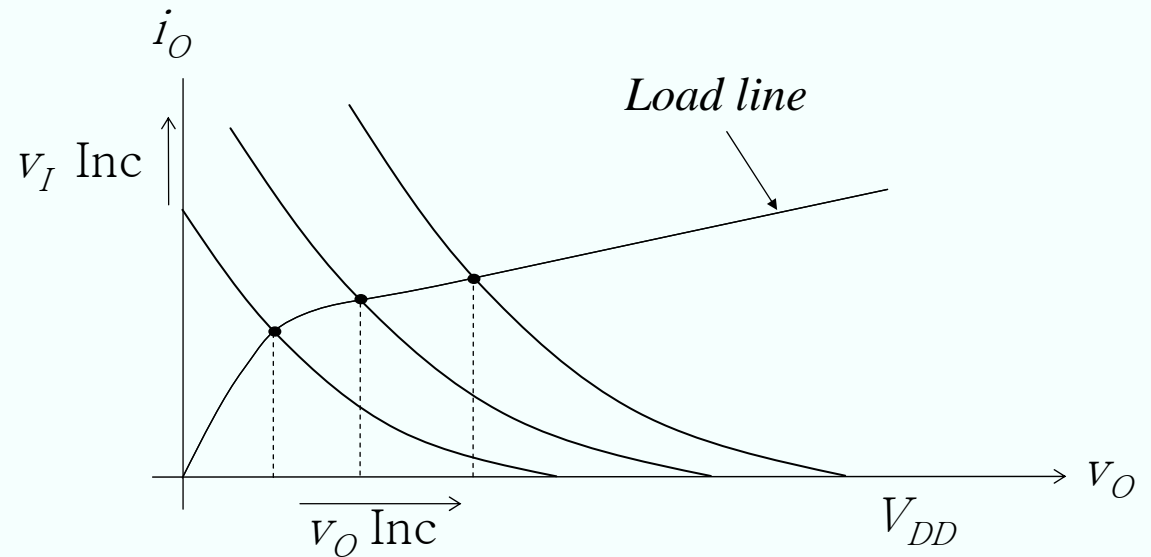
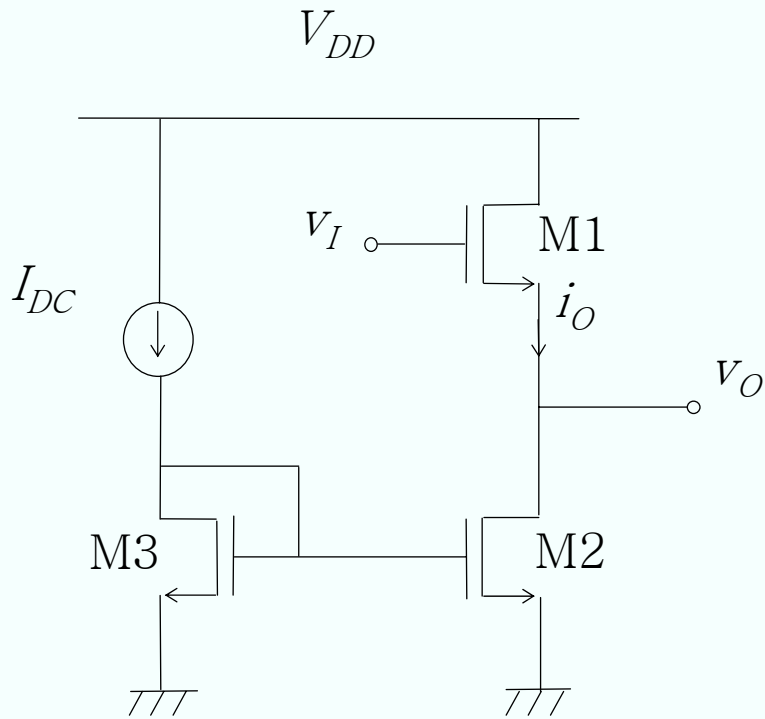

(b)

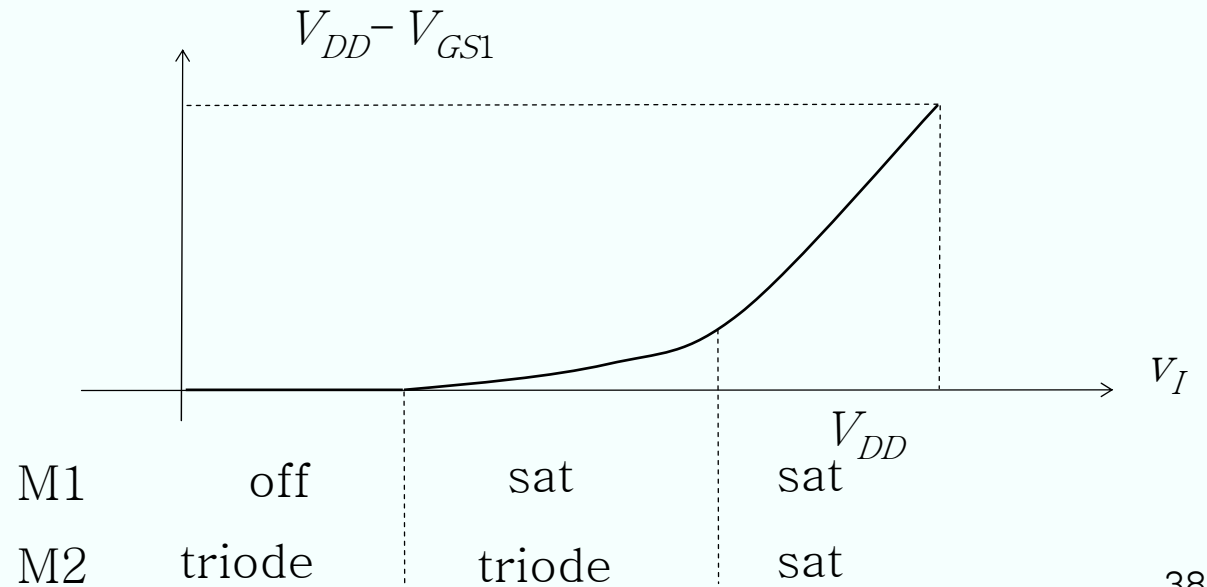

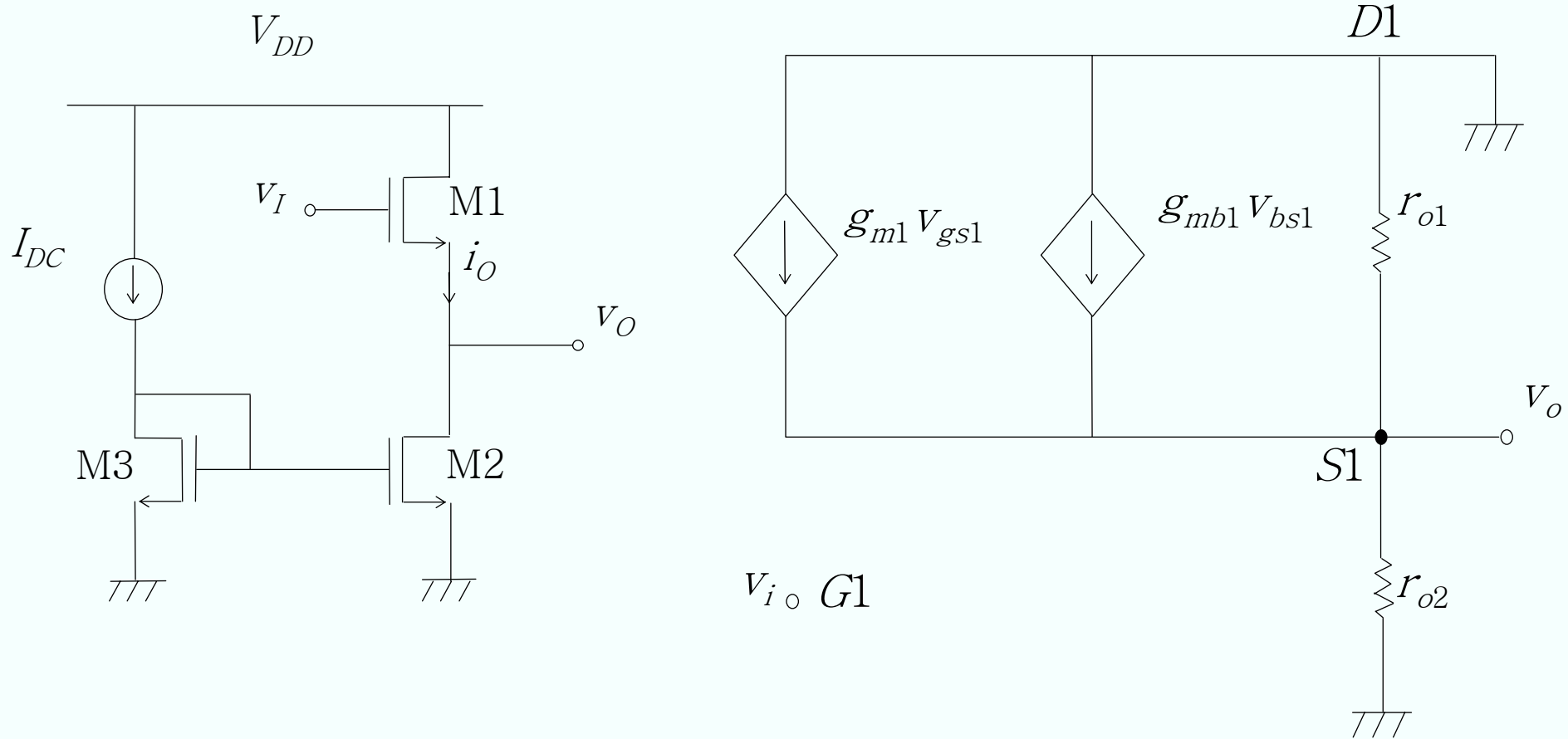

$$A_v$$

$$\Delta$$

$$\frac{v_o}{v_i}$$

$$= \frac{g_{m1}}{g_{m1} + g_{mb1} + \left( \frac{1}{r_{o1} \parallel r_{o2}} \right)}$$

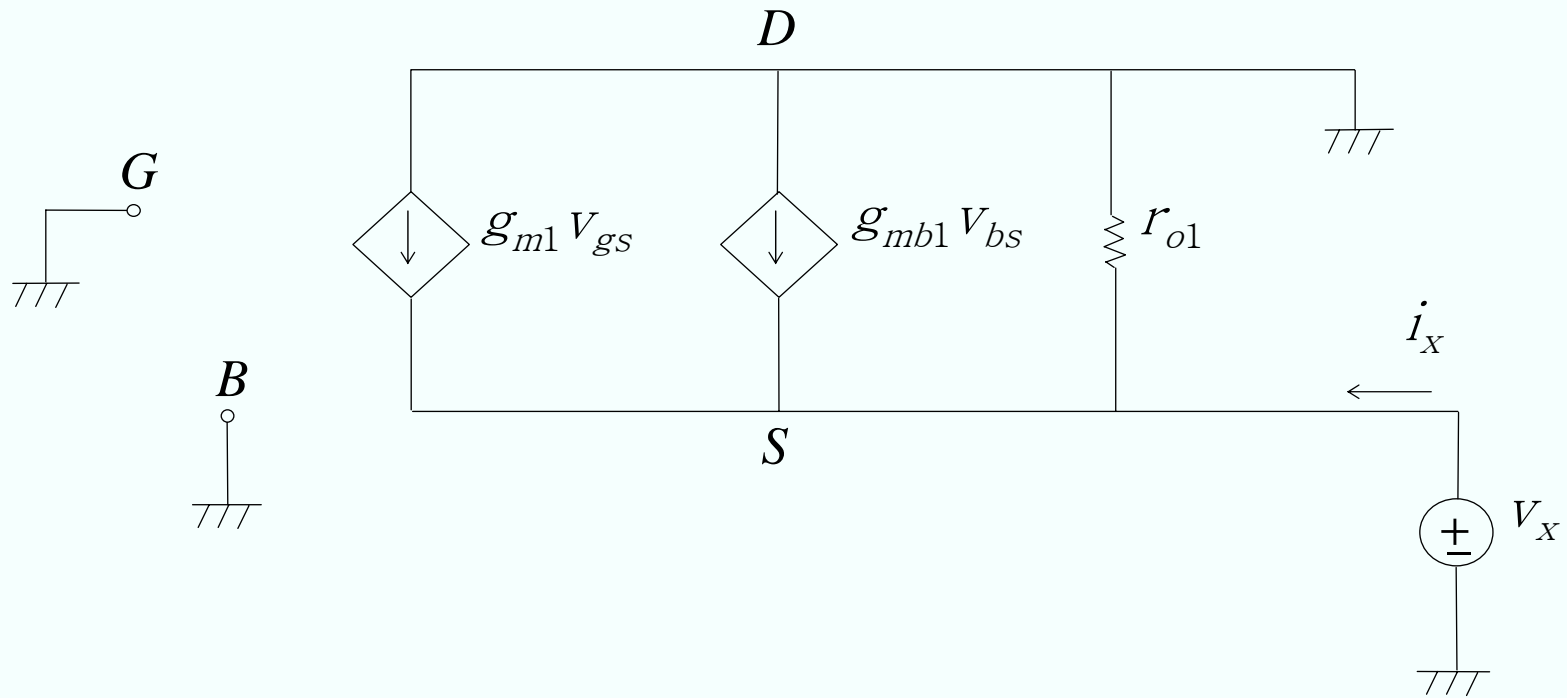

**Fig 4.4.4** Small-signal equivalent circuit to calculate  $R_o$  of CD amp

$$R_o \triangleq \frac{v_x}{i_x} = \frac{1}{g_{m1} + g_{mb1} + \left(\frac{1}{r_{o1}}\right)} \approx \frac{1}{g_{m1} + g_{mb1}} \approx \frac{1}{g_{m1}}$$

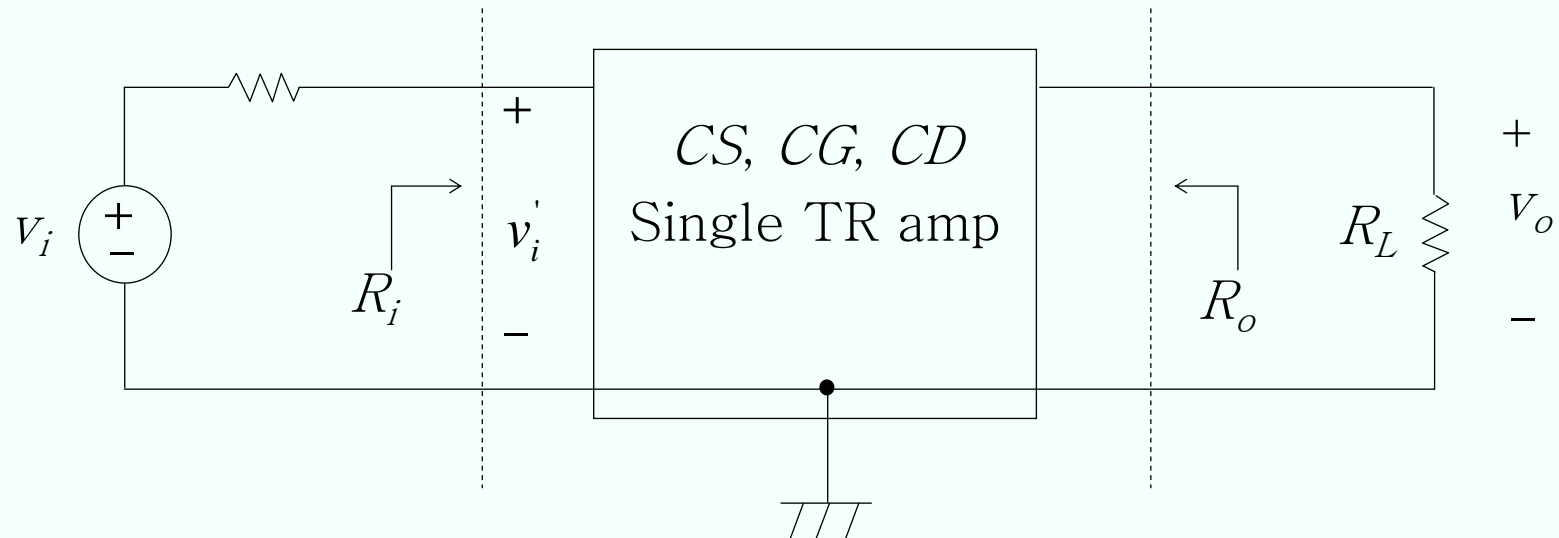

**Fig 4.5.1** Two-port representation of CS, CG, CD single TR amp



	<b>CS amp</b>	<b>CG amp</b>	<b>CD amp</b>
$A'_v$	$-g_m \cdot (r_o \parallel R_L)$	$+(g_m + g_{mb}) \cdot (r_o \parallel R_L)$	$+\frac{g_m}{g_m + g_{mb} + \frac{1}{r_o \parallel R_L}}$
$R_i$	$\infty$	$\frac{1}{g_m + g_{mb} + \frac{1}{r_o}} \cdot \left(1 + \frac{R_L}{r_o}\right)$	$\infty$
$R_o$	$r_o$	$r_o + R_s + (g_m + g_{mb}) \cdot r_o \cdot R_s$	$\frac{1}{g_m + g_{mb}}$
$\omega_{-3dB}$	$\frac{1}{R_s \cdot \left\{ C_{GD} \cdot g_m (r_o \parallel R_L) + C_{GS} \right\} + C_{GB} + C_{GD}}$	$\frac{1}{(R_s \parallel R_i) \cdot (C_{GS} + C_{SB})}$	$\frac{1}{R_s \cdot \left\{ C_{GD} + C_{GB} + C_{GS} \cdot \frac{g_{mb}}{g_m + g_{mb}} \right\}}$
<b>Linear input voltage range (distortion &lt; 10%)</b>	$ v'_i  < 0.2(V_{GS} - V_{TH})$	$ v'_i  < 0.2(V_{GS} - V_{TH})$	$ v'_i  < \left\{ \frac{g_m + g_{mb}}{g_{mb}} \right\} \cdot 0.2(V_{GS} - V_{TH})$
<b>Suitable amp type</b>	<b>Voltage Input Current Output</b>	<b>Current Input Current Output</b>	<b>Voltage Input Voltage Output</b>