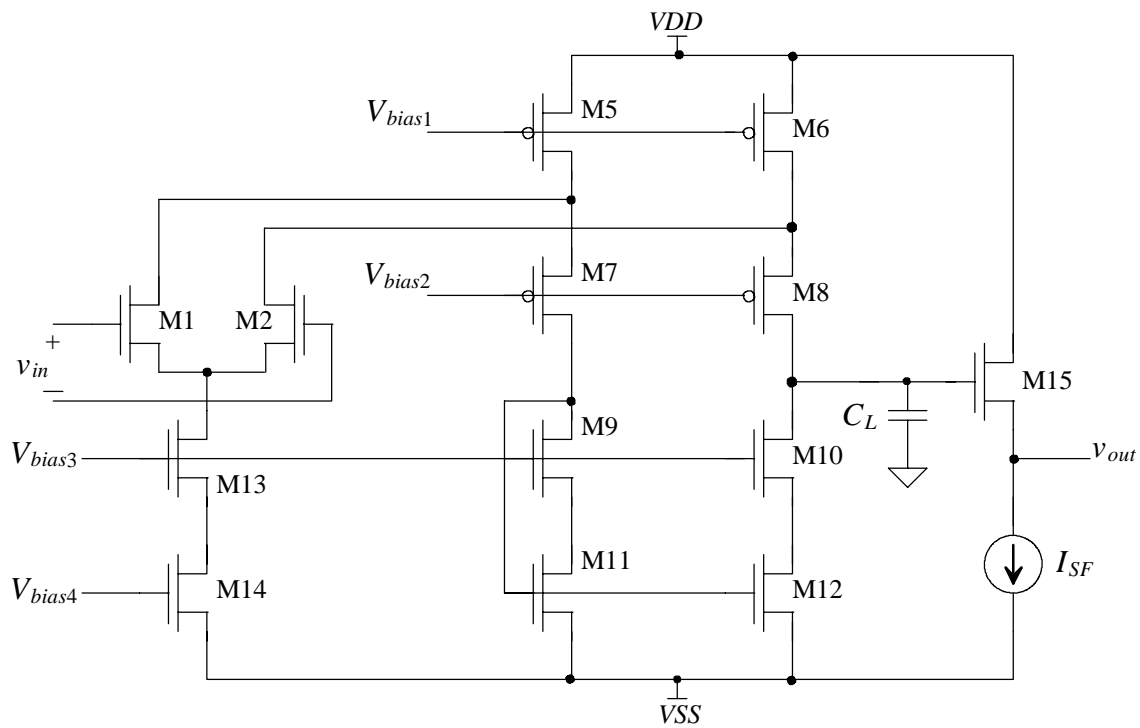
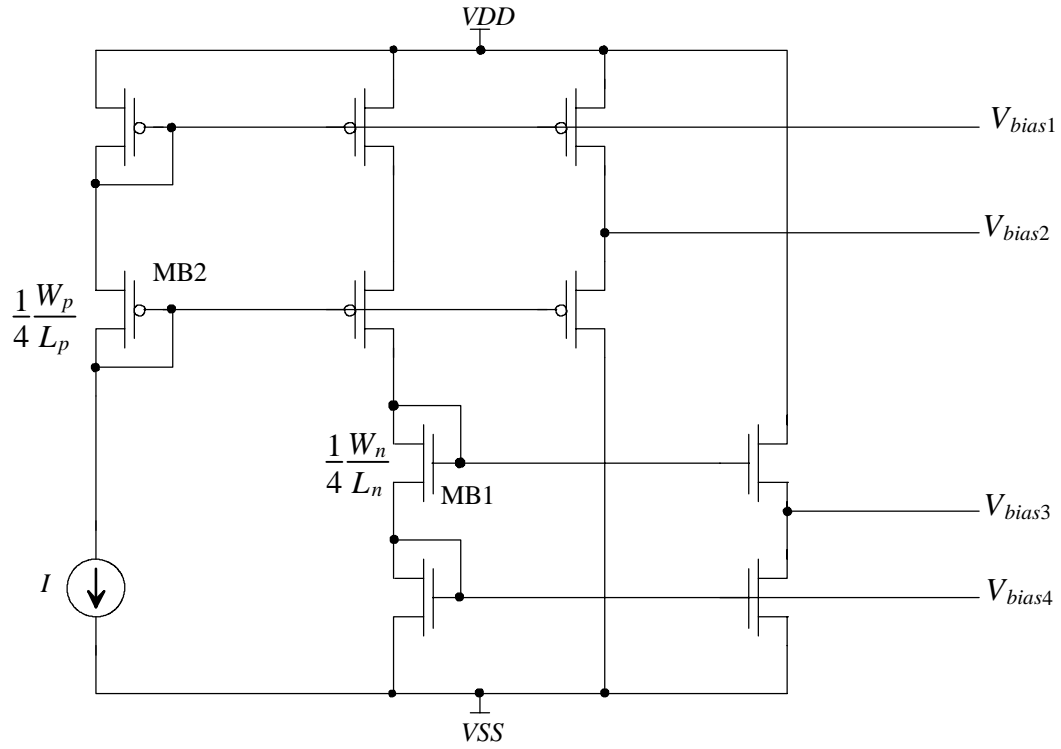

**Figure 25.42** Folded-cascode OTA.



**Figure 25.43** Folded-cascode op-amp.



**Figure 25.44** Biasing circuit for the op-amp of Fig. 25.43.

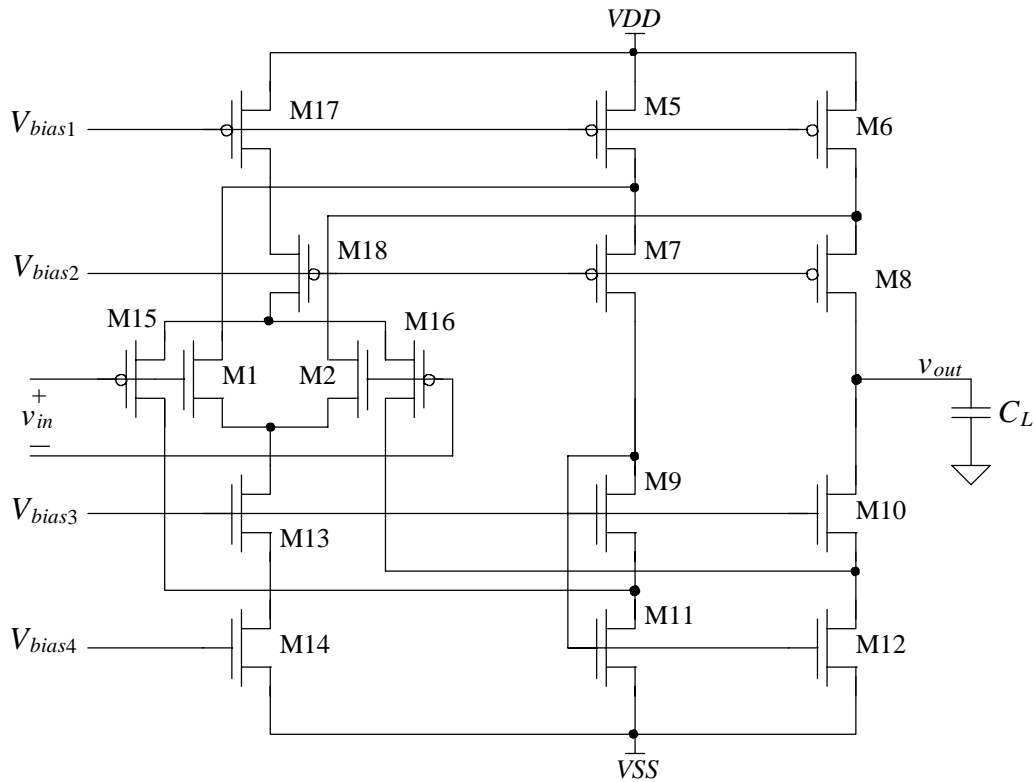

**Figure 25.45** Wide-swing folded-cascode OTA.