

## CHAPTER 6 – CMOS OPERATIONAL AMPLIFIERS

### Chapter Outline

- 6.1 Design of CMOS Op Amps
- 6.2 Compensation of Op Amps
- 6.3 Two-Stage Operational Amplifier Design
- 6.4 Power Supply Rejection Ratio of the Two-Stage Op Amp
- 6.5 Cascode Op Amps
- 6.6 Simulation and Measurement of Op Amps
- 6.7 Macromodels for Op Amps
- 6.8 Summary

### Goal

Understand the analysis, design, and measurement of simple CMOS op amps

### Design Hierarchy

The op amps of this chapter are unbuffered and are OTAs but we will use the generic term “op amp”.

Chapter 6 →

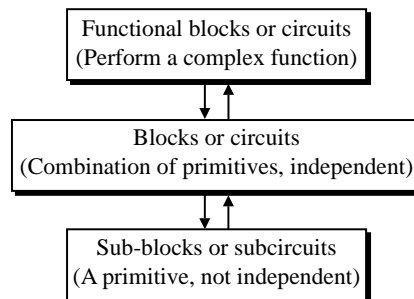

Fig. 6.0-1

© P.E. Allen - 2005

CMOS Analog Circuit Design

## SECTION 6.1 - DESIGN OF CMOS OPERATIONAL AMPLIFIERS

### High-Level Viewpoint of an Op Amp

Block diagram of a general, two-stage op amp:

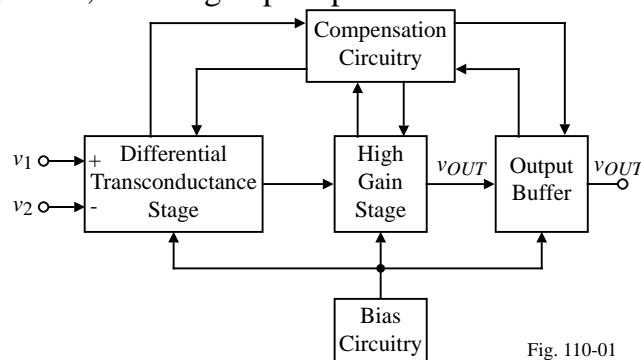

Fig. 110-01

- **Differential transconductance stage:**  
Forms the input and sometimes provides the differential-to-single ended conversion.
- **High gain stage:**  
Provides the voltage gain required by the op amp together with the input stage.
- **Output buffer:**  
Used if the op amp must drive a low resistance.
- **Compensation:**  
Necessary to keep the op amp stable when resistive negative feedback is applied.

## Ideal Op Amp

Symbol:

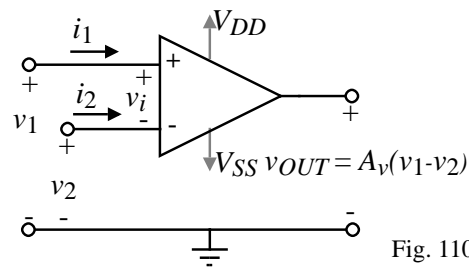

Fig. 110-02

Null port:

If the differential gain of the op amp is large enough then input terminal pair becomes a null port.

A null port is a pair of terminals where the voltage is zero and the current is zero.

I.e.,

$$v_1 - v_2 = v_i = 0$$

and

$$i_1 = 0 \text{ and } i_2 = 0$$

Therefore, ideal op amps can be analyzed by assuming the differential input voltage is zero and that no current flows into or out of the differential inputs.

## General Configuration of the Op Amp as a Voltage Amplifier

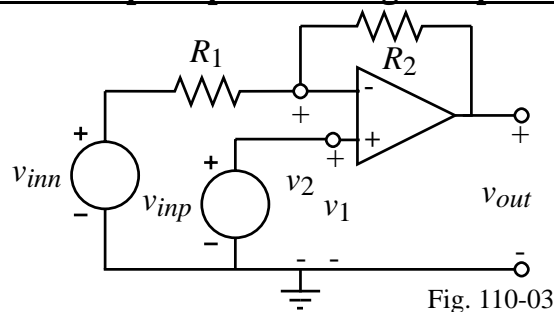

Fig. 110-03

Noninverting voltage amplifier:

$$v_{inn} = 0 \quad \Rightarrow \quad v_{out} = \left( \frac{R_1 + R_2}{R_1} \right) v_{inp}$$

Inverting voltage amplifier:

$$v_{inp} = 0 \quad \Rightarrow \quad v_{out} = - \left( \frac{R_2}{R_1} \right) v_{inn}$$

### Example 6.1-1 - Simplified Analysis of an Op Amp Circuit

The circuit shown below is an inverting voltage amplifier using an op amp. Find the voltage transfer function,  $v_{out}/v_{in}$ .

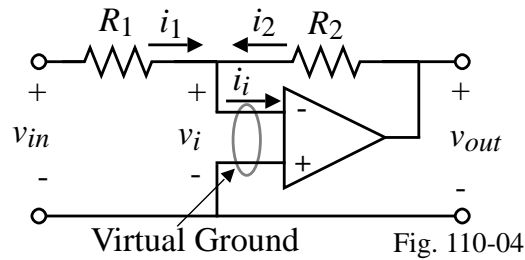

#### Solution

If  $A_v \rightarrow \infty$ , then  $v_i \rightarrow 0$  because of the negative feedback path through  $R_2$ .

(The op amp with  $-fb$ . makes its input terminal voltages equal.)

$$v_i = 0 \text{ and } i_i = 0$$

Note that the null port becomes the familiar *virtual ground* if one of the op amp input terminals is on ground. If this is the case, then we can write that

$$i_1 = \frac{v_{in}}{R_1} \quad \text{and} \quad i_2 = \frac{v_{out}}{R_2}$$

Since,  $i_i = 0$ , then  $i_1 + i_2 = 0$  giving the desired result as  $\frac{v_{out}}{v_{in}} = -\frac{R_2}{R_1}$ .

### Linear and Static Characterization of the Op Amp

A model for a nonideal op amp that includes some of the linear, static nonidealities:

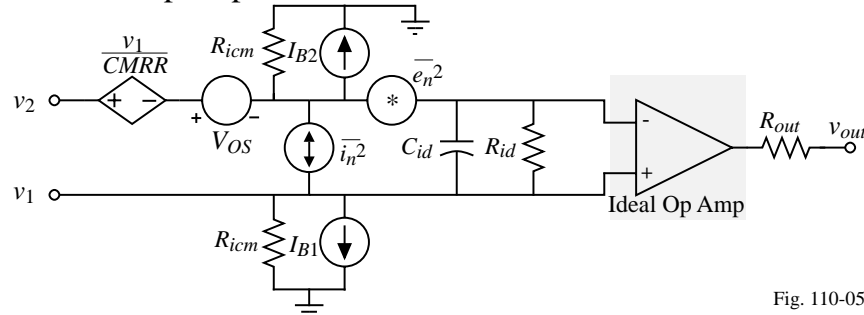

Fig. 110-05

where

$R_{id}$  = differential input resistance

$C_{id}$  = differential input capacitance

$R_{icm}$  = common mode input resistance

$V_{OS}$  = input-offset voltage

$I_{B1}$  and  $I_{B2}$  = differential input-bias currents

$I_{OS}$  = input-offset current ( $I_{OS} = I_{B1} - I_{B2}$ )

$CMRR$  = common-mode rejection ratio

$e_n^2$  = voltage-noise spectral density (mean-square volts/Hertz)

$i_n^2$  = current-noise spectral density (mean-square amps/Hertz)

## Linear and Dynamic Characteristics of the Op Amp

Differential and common-mode frequency response:

$$V_{out}(s) = A_v(s)[V_1(s) - V_2(s)] \pm A_c(s) \left( \frac{V_1(s) + V_2(s)}{2} \right)$$

Differential-frequency response:

$$A_v(s) = \frac{A_{v0}}{\left(\frac{s}{p_1} - 1\right)\left(\frac{s}{p_2} - 1\right)\left(\frac{s}{p_3} - 1\right)\cdots} = \frac{A_{v0} p_1 p_2 p_3 \cdots}{(s - p_1)(s - p_2)(s - p_3)\cdots}$$

where  $p_1, p_2, p_3, \dots$  are the poles of the differential-frequency response (ignoring zeros).

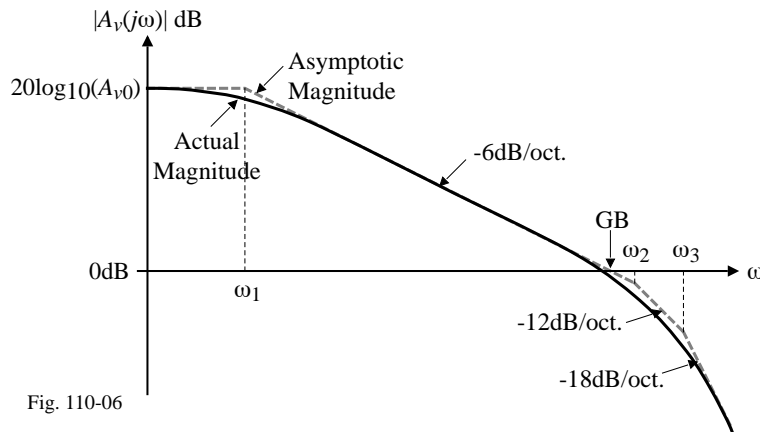

Fig. 110-06

## Other Characteristics of the Op Amp

Power supply rejection ratio (*PSRR*):

$$PSRR = \frac{\Delta V_{DD}}{\Delta V_{OUT}} A_v(s) = \frac{V_o/V_{in} (V_{dd} = 0)}{V_o/V_{dd} (V_{in} = 0)}$$

Input common mode range (*ICMR*):

*ICMR* = the voltage range over which the input common-mode signal can vary without influence the differential performance

Slew rate (*SR*):

*SR* = output voltage rate limit of the op amp

Settling time ( $T_s$ ):

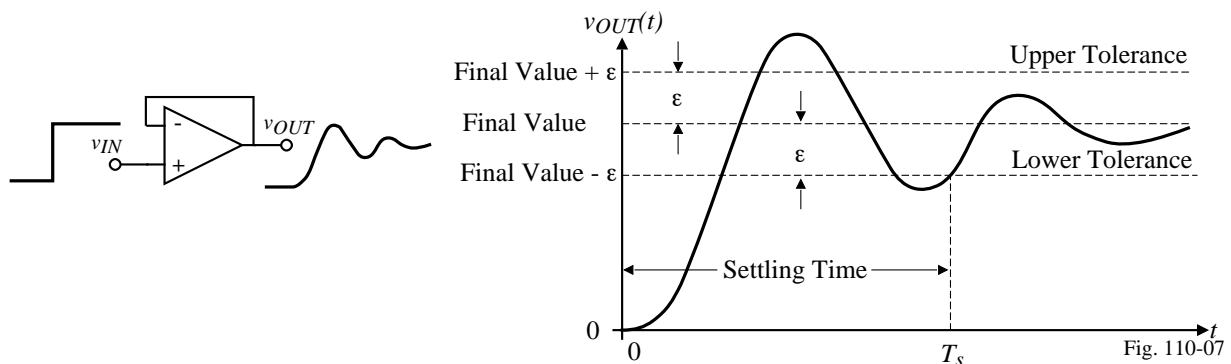

Fig. 110-07

### Classification of CMOS Op Amps

Categorization of op amps:

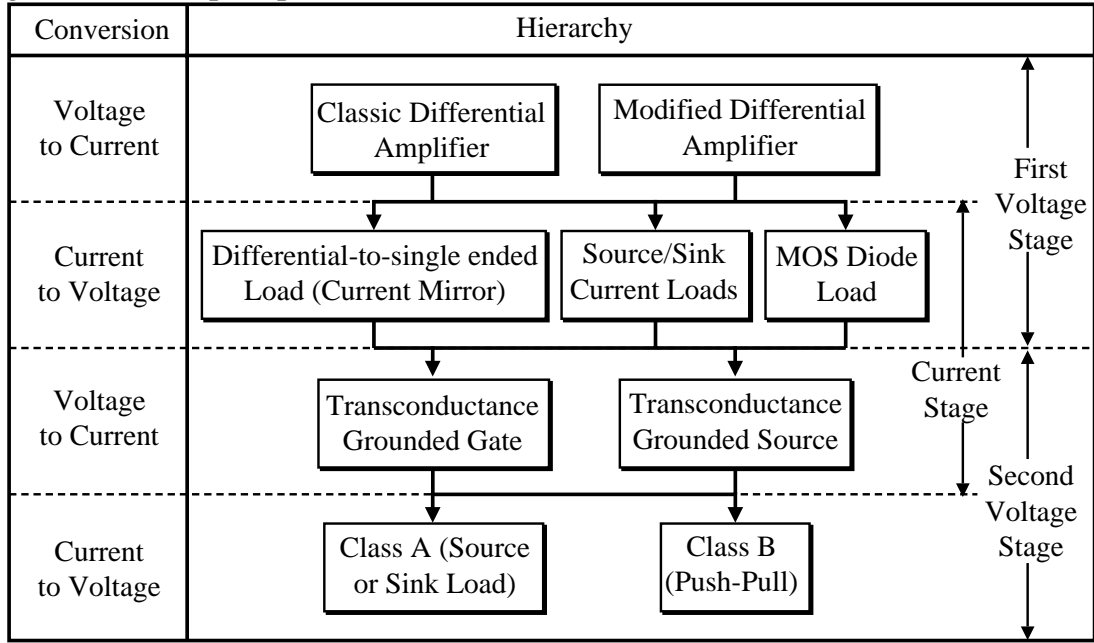

Table 110-01

### Two-Stage CMOS Op Amp

Classical two-stage CMOS op amp broken into voltage-to-current and current-to-voltage stages:

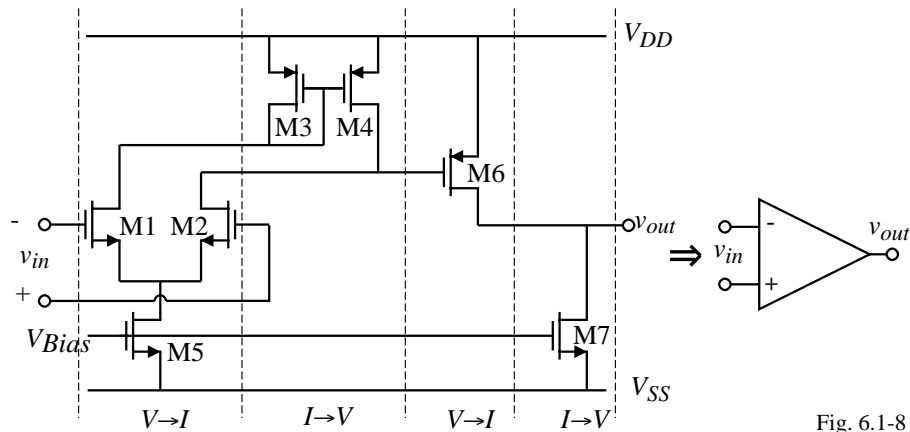

Fig. 6.1-8

## Folded Cascode CMOS Op Amp

Folded cascode CMOS op amp broken into stages.

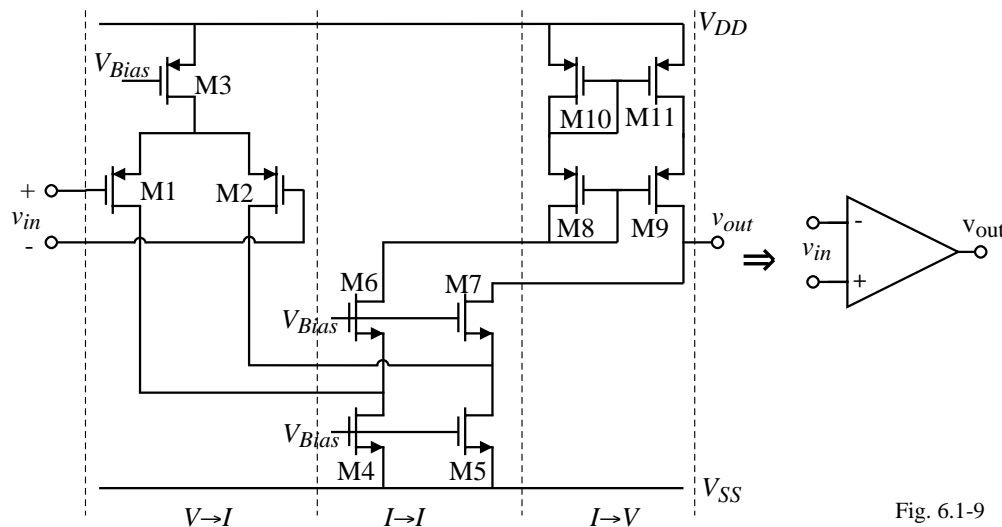

Fig. 6.1-9

## Design of CMOS Op Amps

Steps:

- 1.) Choosing or creating the basic structure of the op amp.
  - This step results in a schematic showing the transistors and their interconnections. This diagram does not change throughout the remainder of the design unless the specifications cannot be met, then a new or modified structure must be developed.
- 2.) Selection of the dc currents and transistor sizes.
  - Most of the effort of design is in this category. Simulators are used to aid the designer in this phase. The general performance of the circuit should be known a priori.
- 3.) Physical implementation of the design.
  - Layout of the transistors
  - Floorplanning the connections, pin-outs, power supply buses and grounds
  - Extraction of the physical parasitics and resimulation
  - Verification that the layout is a physical representation of the circuit.
- 4.) Fabrication
- 5.) Measurement
  - Verification of the specifications
  - Modification of the design as necessary

## **Boundary Conditions and Requirements for CMOS Op Amps**

Boundary conditions:

1. Process specification ( $V_T$ ,  $K'$ ,  $C_{ox}$  etc.)
2. Supply voltage and range
3. Supply current and range
4. Operating temperature and range

Requirements:

1. Gain
2. Gain bandwidth
3. Settling time
4. Slew rate
5. Common-mode input range,  $ICMR$
6. Common-mode rejection ratio,  $CMRR$
7. Power-supply rejection ratio,  $PSRR$
8. Output-voltage swing
9. Output resistance
10. Offset
11. Noise
12. Layout area

## **Specifications for a Typical Unbuffered CMOS Op Amp**

Boundary Conditions	Requirement
Process Specification	See Tables 3.1-1 and 3.1-2
Supply Voltage	$\pm 2.5 \text{ V} \pm 10\%$
Supply Current	$100 \mu\text{A}$
Temperature Range	0 to $70^\circ\text{C}$
Specifications	Value
Gain	$\geq 70 \text{ dB}$
Gainbandwidth	$\geq 5 \text{ MHz}$
Settling Time	$\leq 1 \mu\text{sec}$
Slew Rate	$\geq 5 \text{ V}/\mu\text{sec}$
Input $CMR$	$\geq \pm 1.5 \text{ V}$
$CMRR$	$\geq 60 \text{ dB}$
$PSRR$	$\geq 60 \text{ dB}$
Output Swing	$\geq \pm 1.5 \text{ V}$
Output Resistance	N/A, capacitive load only
Offset	$\leq \pm 10 \text{ mV}$
Noise	$\leq 100 \text{ nV}/\sqrt{\text{Hz}}$ at 1KHz
Layout Area	$\leq 10,000 \text{ min. channel length}^2$

## **Some Practical Thoughts on Op Amp Design**

- 1.) Decide upon a suitable topology.
  - Experience is a great help
  - The topology should be the one capable of meeting most of the specifications
  - Try to avoid “inventing” a new topology but start with an existing topology
- 2.) Determine the type of compensation needed to meet the specifications.
  - Consider the load and stability requirements
  - Use some form of Miller compensation or a self-compensated approach (shown later)
- 3.) Design dc currents and device sizes for proper dc, ac, and transient performance.
  - This begins with hand calculations based upon approximate design equations.
  - Compensation components are also sized in this step of the procedure.
  - After each device is sized by hand, a circuit simulator is used to fine tune the design

Two basic steps of design:

- 1.) “First-cut” - this step is to use hand calculations to propose a design that has potential of satisfying the specifications. Design robustness is developed in this step.
- 2.) Optimization - this step uses the computer to refine and optimize the design.

## **SECTION 6.2 - COMPENSATION OF OP AMPS**

### **Compensation**

#### **Objective**

Objective of compensation is to achieve stable operation when negative feedback is applied around the op amp.

#### **Types of Compensation**

1. Miller - Use of a capacitor feeding back around a high-gain, inverting stage.
  - Miller capacitor only
  - Miller capacitor with an unity-gain buffer to block the forward path through the compensation capacitor. Can eliminate the RHP zero.
  - Miller with a nulling resistor. Similar to Miller but with an added series resistance to gain control over the RHP zero.
2. Self compensating - Load capacitor compensates the op amp (later).
3. Feedforward - Bypassing a positive gain amplifier resulting in phase lead. Gain can be less than unity.

## Single-Loop, Negative Feedback Systems

Block diagram:

$A(s)$  = differential-mode voltage gain of the op amp

$F(s)$  = feedback transfer function from the output of op amp back to the input.

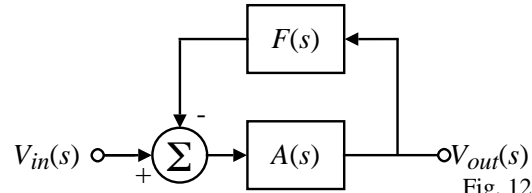

Fig. 120-01

Definitions:

- Open-loop gain =  $L(s) = -A(s)F(s)$
- Closed-loop gain =  $\frac{V_{out}(s)}{V_{in}(s)} = \frac{A(s)}{1+A(s)F(s)}$

Stability Requirements:

The requirements for stability for a single-loop, negative feedback system is,

$$|A(j\omega_0^\circ)F(j\omega_0^\circ)| = |L(j\omega_0^\circ)| < 1$$

where  $\omega_0^\circ$  is defined as

$$\text{Arg}[-A(j\omega_0^\circ)F(j\omega_0^\circ)] = \text{Arg}[L(j\omega_0^\circ)] = 0^\circ$$

Another convenient way to express this requirement is

$$\text{Arg}[-A(j\omega_{0dB})F(j\omega_{0dB})] = \text{Arg}[L(j\omega_{0dB})] > 0^\circ$$

where  $\omega_{0dB}$  is defined as

$$|A(j\omega_{0dB})F(j\omega_{0dB})| = |L(j\omega_{0dB})| = 1$$

## Illustration of the Stability Requirement using Bode Plots

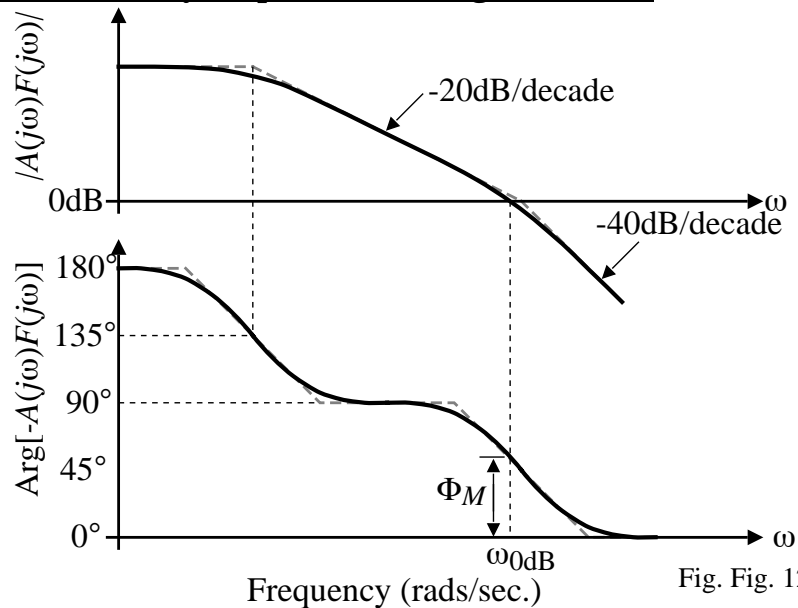

Fig. Fig. 120-02

A measure of stability is given by the phase when  $|A(j\omega)F(j\omega)| = 1$ . This phase is called *phase margin*.

$$\text{Phase margin} = \Phi_M = \text{Arg}[-A(j\omega_{0dB})F(j\omega_{0dB})] = \text{Arg}[L(j\omega_{0dB})]$$

### Why Do We Want Good Stability?

Consider the step response of second-order system which closely models the closed-loop gain of the op amp.

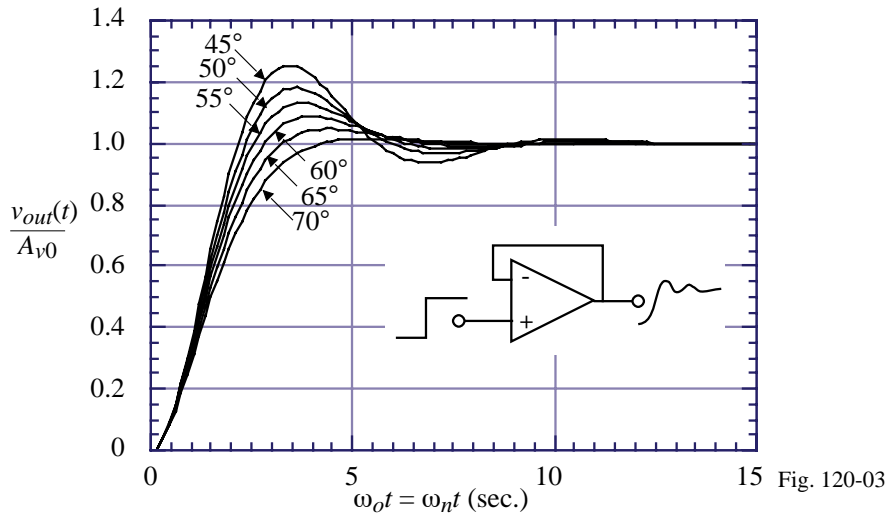

A “good” step response is one that quickly reaches its final value. Therefore, we see that phase margin should be at least 45° and preferably 60° or larger. (A rule of thumb for satisfactory stability is that there should be less than three rings.) Note that good stability is not necessarily the quickest risetime.

### Uncompensated Frequency Response of Two-Stage Op Amps

Two-Stage Op Amps:

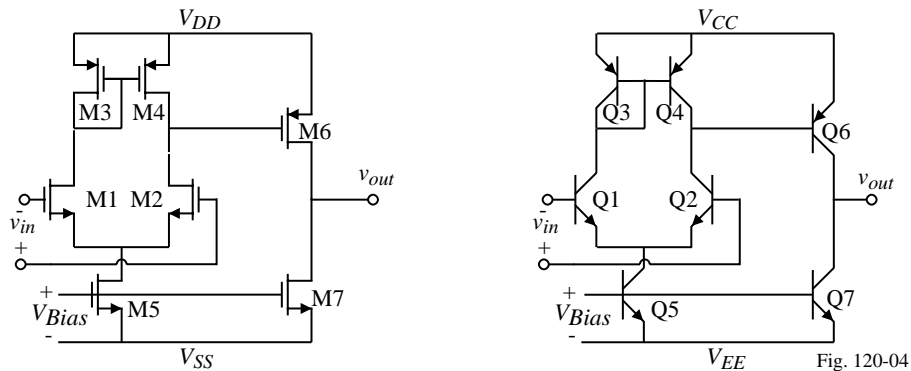

Small-Signal Model:

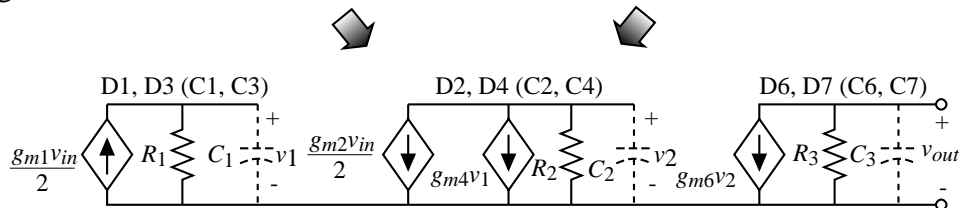

Fig. 120-05

Note that this model neglects the base-collector and gate-drain capacitances for purposes of simplification.

### Uncompensated Frequency Response of Two-Stage Op Amps - Continued

For the MOS two-stage op amp:

$$R_1 \approx \frac{1}{g_{m3}} \parallel r_{ds3} \parallel r_{ds1} \approx \frac{1}{g_{m3}} \quad R_2 = r_{ds2} \parallel r_{ds4} \quad \text{and} \quad R_3 = r_{ds6} \parallel r_{ds7}$$

$$C_1 = C_{gs3} + C_{gs4} + C_{bd1} + C_{bd3} \quad C_2 = C_{gs6} + C_{bd2} + C_{bd4} \quad \text{and} \quad C_3 = C_L + C_{bd6} + C_{bd7}$$

For the BJT two-stage op amp:

$$R_1 = \frac{1}{g_{m3}} \parallel r_{\pi3} \parallel r_{\pi4} \parallel r_{o1} \parallel r_{o3} \approx \frac{1}{g_{m3}} \quad R_2 = r_{\pi6} \parallel r_{o2} \parallel r_{o4} \approx r_{\pi6} \quad \text{and} \quad R_3 = r_{o6} \parallel r_{o7}$$

$$C_1 = C_{\pi3} + C_{\pi4} + C_{cs1} + C_{cs3} \quad C_2 = C_{\pi6} + C_{cs2} + C_{cs4} \quad \text{and} \quad C_3 = C_L + C_{cs6} + C_{cs7}$$

Assuming the pole due to  $C_1$  is much greater than the poles due to  $C_2$  and  $C_3$  gives,

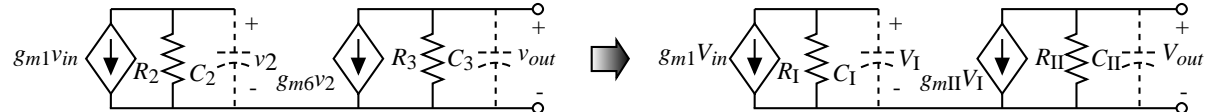

Fig. 120-06

The locations for the two poles are given by the following equations

$$p'_1 = \frac{-1}{R_1 C_1} \quad \text{and} \quad p'_2 = \frac{-1}{R_{II} C_{II}}$$

where  $R_I$  ( $R_{II}$ ) is the resistance to ground seen from the output of the first (second) stage and  $C_I$  ( $C_{II}$ ) is the capacitance to ground seen from the output of the first (second) stage.

### Uncompensated Frequency Response of an Op Amp

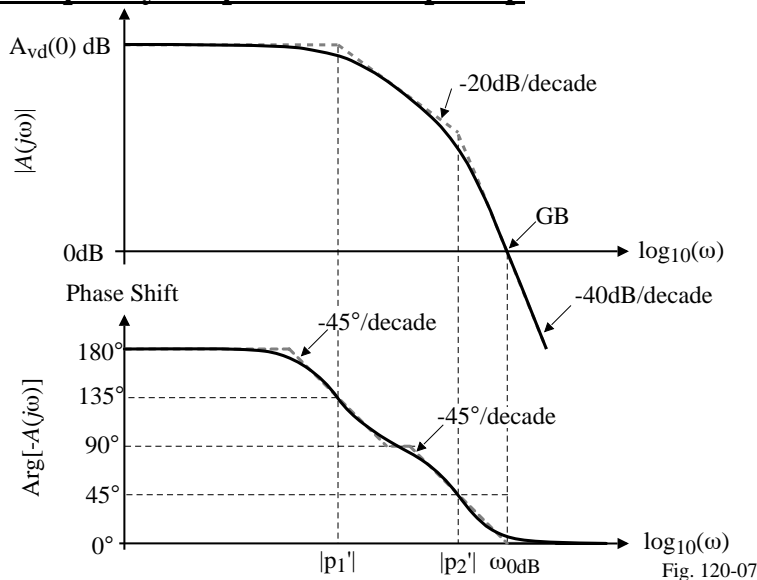

Fig. 120-07

If we assume that  $F(s) = 1$  (this is the worst case for stability considerations), then the above plot is the same as the loop gain.

Note that the phase margin is much less than  $45^\circ$ .

Therefore, the op amp must be compensated before using it in a closed-loop configuration.

### Miller Compensation of the Two-Stage Op Amp

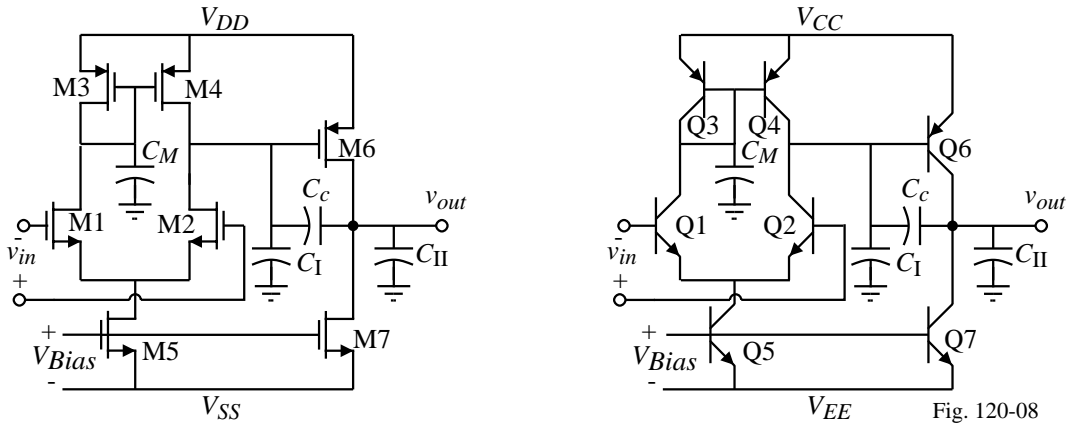

Fig. 120-08

The various capacitors are:

- $C_c$  = accomplishes the Miller compensation
- $C_M$  = capacitance associated with the first-stage mirror (mirror pole)
- $C_I$  = output capacitance to ground of the first-stage
- $C_{II}$  = output capacitance to ground of the second-stage

### Compensated Two-Stage, Small-Signal Frequency Response Model Simplified

Use the CMOS op amp to illustrate:

- 1.) Assume that  $g_{m3} \gg g_{ds3} + g_{ds1}$
- 2.) Assume that  $\frac{g_{m3}}{C_M} \gg GB$

Therefore,

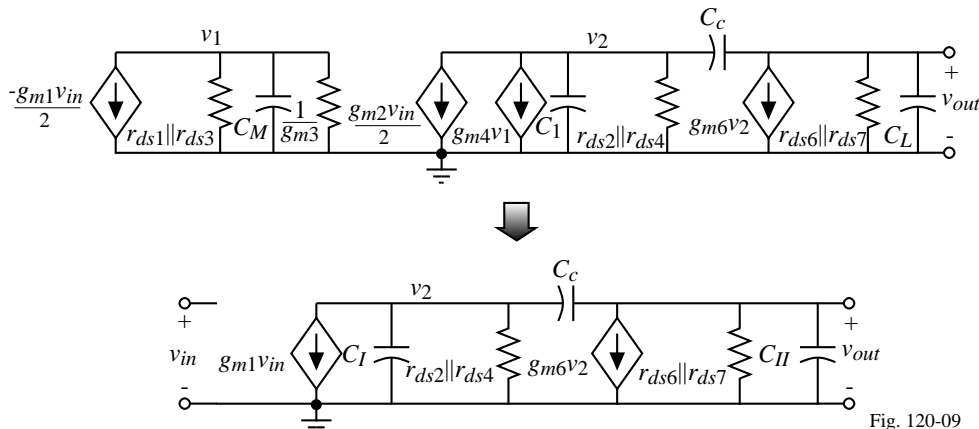
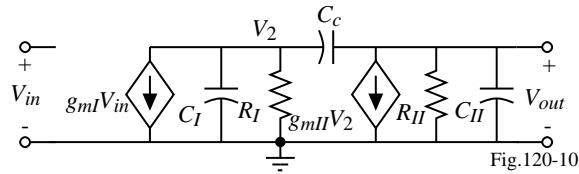

Fig. 120-09

Same circuit holds for the BJT op amp with different component relationships.

### General Two-Stage Frequency Response Analysis



where

$$g_{mI} = g_{m1} = g_{m2}, R_I = r_{ds2} || r_{ds4}, C_I = C_1$$

and

$$g_{mII} = g_{m6}, R_{II} = r_{ds6} || r_{ds7}, C_{II} = C_2 = C_L$$

Nodal Equations:

$$-g_{mI}V_{in} = [G_I + s(C_I + C_c)]V_2 - [sC_c]V_{out} \quad \text{and} \quad 0 = [g_{mII} - sC_c]V_2 + [G_{II} + sC_{II} + sC_c]V_{out}$$

Solving using Cramer's rule gives,

$$\begin{aligned} \frac{V_{out}(s)}{V_{in}(s)} &= \frac{g_{mI}(g_{mII} - sC_c)}{G_I G_{II} + s [G_{II}(C_I + C_{II}) + G_I(C_{II} + C_c) + g_{mII}C_c] + s^2 [C_I C_{II} + C_c C_I + C_c C_{II}]} \\ &= \frac{A_o [1 - s(C_c/g_{mII})]}{1 + s [R_I(C_I + C_{II}) + R_{II}(C_{II} + C_c) + g_{mII}R_I R_{II}C_c] + s^2 [R_I R_{II}(C_I C_{II} + C_c C_I + C_c C_{II})]} \end{aligned}$$

where,  $A_o = g_{mI}g_{mII}R_I R_{II}$

$$\text{In general, } D(s) = \left(1 - \frac{s}{p_1}\right) \left(1 - \frac{s}{p_2}\right) = 1 - s \left(\frac{1}{p_1} + \frac{1}{p_2}\right) + \frac{s^2}{p_1 p_2} \rightarrow D(s) \approx 1 - \frac{s}{p_1} + \frac{s^2}{p_1 p_2}, \text{ if } |p_2| \gg |p_1|$$

$$\therefore \boxed{p_1 = \frac{-1}{R_I(C_I + C_{II}) + R_{II}(C_{II} + C_c) + g_{mII}R_I R_{II}C_c} \approx \frac{-1}{g_{mII}R_I R_{II}C_c}}, \quad \boxed{z = \frac{g_{mII}}{C_c}}$$

$$p_2 = \frac{-[R_I(C_I + C_{II}) + R_{II}(C_{II} + C_c) + g_{mII}R_I R_{II}C_c]}{R_I R_{II}(C_I C_{II} + C_c C_I + C_c C_{II})} \approx \frac{-g_{mII}C_c}{C_I C_{II} + C_c C_I + C_c C_{II}} \approx \frac{-g_{mII}}{C_{II}}, \quad C_{II} > C_c > C_I$$

CMOS Analog Circuit Design

© P.E. Allen - 2005

### Summary of Results for Miller Compensation of the Two-Stage Op Amp

There are three roots of importance:

1.) Right-half plane zero:

$$z_1 = \frac{g_{mII}}{C_c} = \frac{g_{m6}}{C_c}$$

This root is very undesirable- it boosts the magnitude while decreasing the phase.

2.) Dominant left-half plane pole (the Miller pole):

$$p_1 \approx \frac{-1}{g_{mII}R_I R_{II}C_c} = \frac{-(g_{ds2} + g_{ds4})(g_{ds6} + g_{ds7})}{g_{m6}C_c}$$

This root accomplishes the desired compensation.

3.) Left-half plane output pole:

$$p_2 \approx \frac{-g_{mII}}{C_{II}} \approx \frac{-g_{m6}}{C_L}$$

This pole must be  $\geq$  unity-gainbandwidth or the phase margin will not be satisfied.

Root locus plot of the Miller compensation:

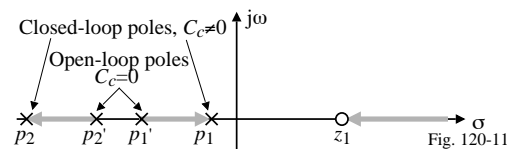

### Compensated Open-Loop Frequency Response of the Two-Stage Op Amp

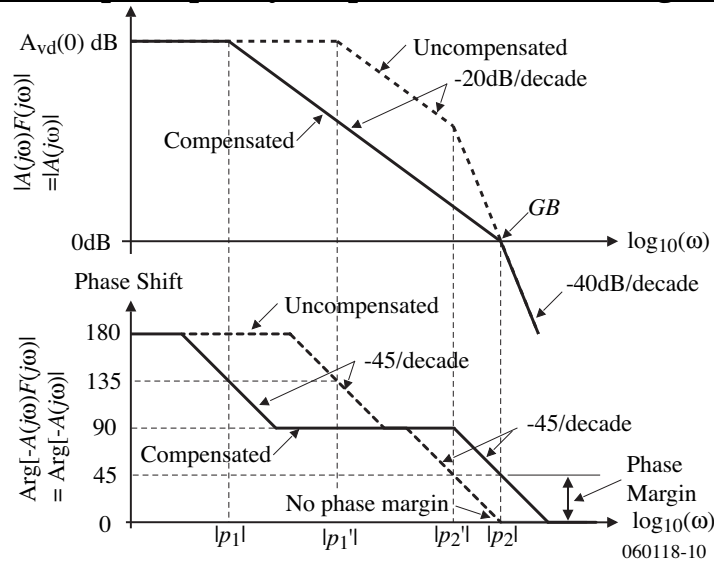

Note that the unity-gainbandwidth,  $GB$ , is

$$GB = A_{vd}(0) \cdot |p_1| = (g_{m1}g_{mII}R_I R_{II}) \frac{1}{g_{mII}R_I R_{II} C_c} = \frac{g_{mI}}{C_c} = \frac{g_{m1}}{C_c} = \frac{g_{m2}}{C_c}$$

### Conceptually, where do these roots come from?

1.) The Miller pole:

$$|p_1| \approx \frac{1}{R_I (g_{m6} R_{II} C_c)}$$

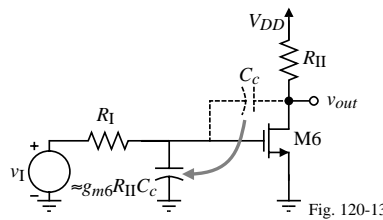

2.) The left-half plane output pole:

$$|p_2| \approx \frac{g_{m6}}{C_{II}}$$

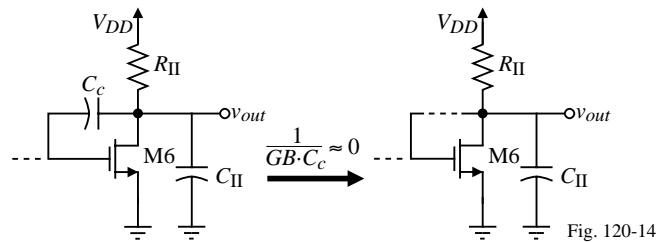

3.) Right-half plane zero (One source of zeros is from multiple paths from the input to output):

$$v_{out} = \left( \frac{-g_{m6} R_{II} (1/s C_c)}{R_{II} + 1/s C_c} \right) v' + \left( \frac{R_{II}}{R_{II} + 1/s C_c} \right) v'' = \frac{-R_{II} (g_{m6} - 1)}{R_{II} + 1/s C_c} v$$

where  $v = v' = v''$ .

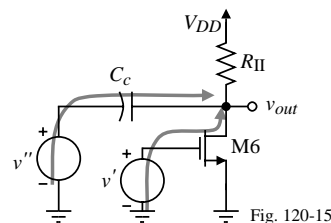

**Influence of the Mirror Pole**

Up to this point, we have neglected the influence of the pole,  $p_3$ , associated with the current mirror of the input stage. A small-signal model for the input stage that includes  $C_3$  is shown below:

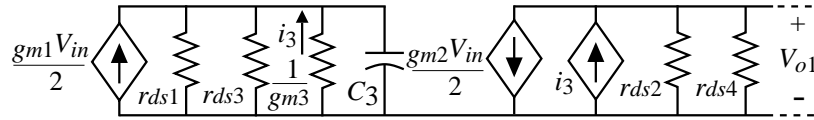

Fig. 120-16

The transfer function from the input to the output voltage of the first stage,  $V_{o1}(s)$ , can be written as

$$\frac{V_{o1}(s)}{V_{in}(s)} = \frac{-g_{m1}}{2(g_{ds2} + g_{ds4})} \left[ \frac{g_{m3} + g_{ds1} + g_{ds3}}{g_{m3} + g_{ds1} + g_{ds3} + sC_3} + 1 \right] \approx \frac{-g_{m1}}{2(g_{ds2} + g_{ds4})} \left[ \frac{sC_3 + 2g_{m3}}{sC_3 + g_{m3}} \right]$$

We see that there is a pole and a zero given as

$$p_3 = -\frac{g_{m3}}{C_3} \quad \text{and} \quad z_3 = -\frac{2g_{m3}}{C_3}$$

**Influence of the Mirror Pole – Continued**

Fortunately, the presence of the zero tends to negate the effect of the pole. Generally, the pole and zero due to  $C_3$  is greater than  $GB$  and will have very little influence on the stability of the two-stage op amp.

The plot shown illustrates the case where these roots are less than  $GB$  and even then they have little effect on stability.

In fact, they actually increase the phase margin slightly because  $GB$  is decreased.

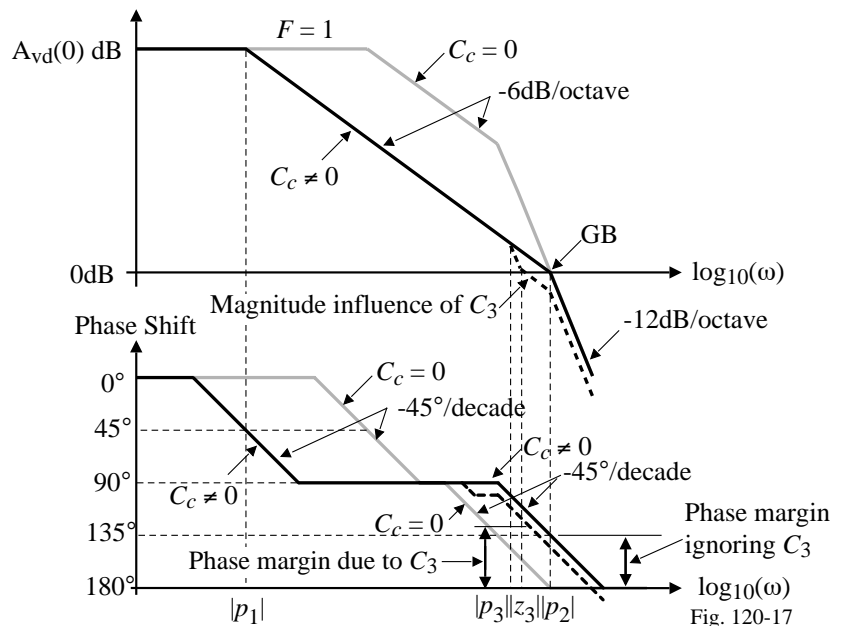

Fig. 120-17

### Summary of the Conditions for Stability of the Two-Stage Op Amp

- Unity-gainbandwidth is given as:

$$GB = A_v(0) \cdot |p_1| = (g_{mI} g_{mII} R_I R_{II}) \cdot \left( \frac{1}{g_{mII} R_I R_{II} C_c} \right) = \frac{g_{mI}}{C_c} = (g_{m1} g_{m2} R_1 R_2) \cdot \left( \frac{1}{g_{m2} R_1 R_2 C_c} \right) = \frac{g_{m1}}{C_c}$$

- The requirement for 45° phase margin is:

$$\pm 180^\circ - \text{Arg}[\text{Loop Gain}] = \pm 180^\circ - \tan^{-1}\left(\frac{\omega}{|p_1|}\right) - \tan^{-1}\left(\frac{\omega}{|p_2|}\right) - \tan^{-1}\left(\frac{\omega}{z}\right) = 45^\circ$$

Let  $\omega = GB$  and assume that  $z \geq 10GB$ , therefore we get,

$$\pm 180^\circ - \tan^{-1}\left(\frac{GB}{|p_1|}\right) - \tan^{-1}\left(\frac{GB}{|p_2|}\right) - \tan^{-1}\left(\frac{GB}{z}\right) = 45^\circ$$

$$135^\circ \approx \tan^{-1}(A_v(0)) + \tan^{-1}\left(\frac{GB}{|p_2|}\right) + \tan^{-1}(0.1) = 90^\circ + \tan^{-1}\left(\frac{GB}{|p_2|}\right) + 5.7^\circ$$

$$39.3^\circ \approx \tan^{-1}\left(\frac{GB}{|p_2|}\right) \Rightarrow \frac{GB}{|p_2|} = 0.818 \Rightarrow \boxed{|p_2| \geq 1.22GB}$$

- The requirement for 60° phase margin:

$$\boxed{|p_2| \geq 2.2GB \text{ if } z \geq 10GB}$$

- If 60° phase margin is required, then the following relationships apply:

$$\frac{g_{m6}}{C_c} > \frac{10g_{m1}}{C_c} \Rightarrow \boxed{g_{m6} > 10g_{m1}} \quad \text{and} \quad \frac{g_{m6}}{C_2} > \frac{2.2g_{m1}}{C_c} \Rightarrow \boxed{C_c > 0.22C_2}$$

### Controlling the Right-Half Plane Zero

Why is the RHP zero a problem?

Because it boosts the magnitude but lags the phase - the worst possible combination for stability.

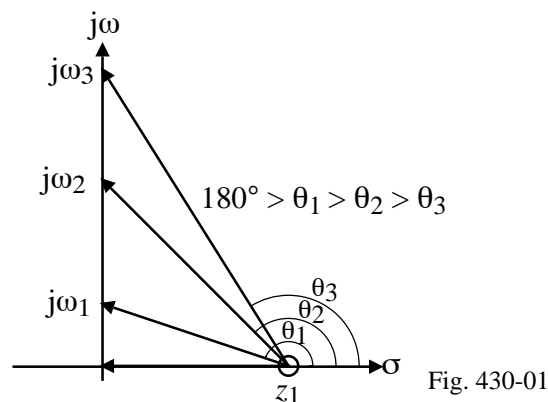

Fig. 430-01

Solution of the problem:

If a zero is caused by two paths to the output, then eliminate one of the paths.

## Use of Buffer to Eliminate the Feedforward Path through the Miller Capacitor

Model:

The transfer function is given by the following equation,

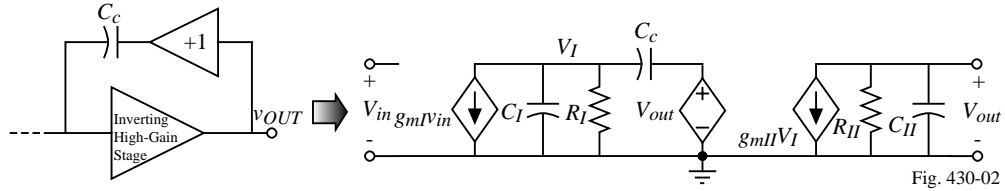

Fig. 430-02

$$\frac{V_o(s)}{V_{in}(s)} = \frac{(g_{mI})(g_{mII})(R_I)(R_{II})}{1 + s[R_I C_I + R_{II} C_{II} + R_I C_c + g_{mII} R_I R_{II} C_c] + s^2[R_I R_{II} C_{II} (C_I + C_c)]}$$

Using the technique as before to approximate  $p_1$  and  $p_2$  results in the following

$$p_1 \approx \frac{-1}{R_I C_I + R_{II} C_{II} + R_I C_c + g_{mII} R_I R_{II} C_c} \approx \frac{-1}{g_{mII} R_I R_{II} C_c}$$

and

$$p_2 \approx \frac{-g_{mII} C_c}{C_{II} (C_I + C_c)}$$

Comments:

Poles are approximately what they were before with the zero removed.

For 45° phase margin,  $|p_2|$  must be greater than  $GB$

For 60° phase margin,  $|p_2|$  must be greater than  $1.73GB$

## Use of Buffer with Finite Output Resistance to Eliminate the RHP Zero

Assume that the unity-gain buffer has an output resistance of  $R_o$ .

Model:

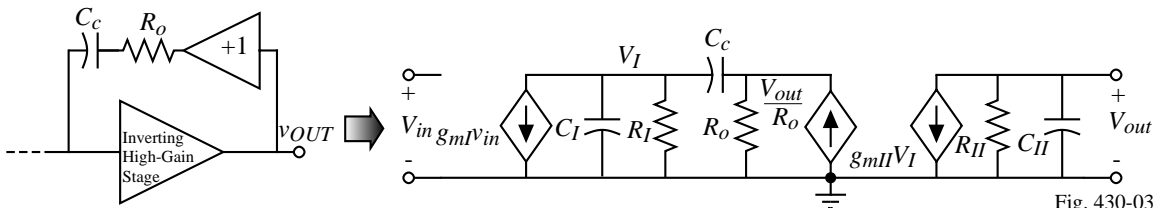

Fig. 430-03

It can be shown that if the output resistance of the buffer amplifier,  $R_o$ , is not neglected that another pole occurs at,

$$p_4 \approx \frac{-1}{R_o [C_I C_c / (C_I + C_c)]}$$

and a LHP zero at

$$z_2 \approx \frac{-1}{R_o C_c}$$

Closer examination shows that if a resistor, called a *nulling resistor*, is placed in series with  $C_c$  that the RHP zero can be eliminated or moved to the LHP.

## Use of Nulling Resistor to Eliminate the RHP Zero (or turn it into a LHP zero)<sup>†</sup>

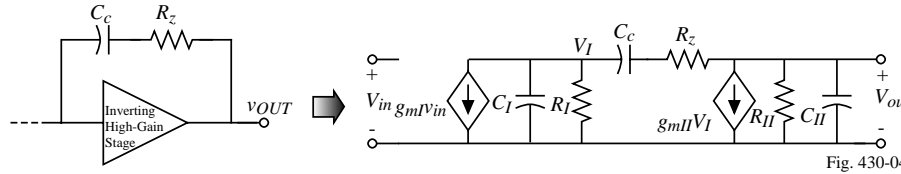

Nodal equations:

$$g_{mI}V_{in} + \frac{V_I}{R_I} + sC_I V_I + \left( \frac{sC_c}{1 + sC_c R_z} \right) (V_I - V_{out}) = 0$$

$$g_{mII}V_I + \frac{V_o}{R_{II}} + sC_{II}V_{out} + \left( \frac{sC_c}{1 + sC_c R_z} \right) (V_{out} - V_I) = 0$$

Solution:

$$\frac{V_{out}(s)}{V_{in}(s)} = \frac{a\{1 - s[(C_c/g_{mII}) - R_z C_c]\}}{1 + bs + cs^2 + ds^3}$$

where

$$a = g_{mI}g_{mII}R_I R_{II}$$

$$b = (C_{II} + C_c)R_{II} + (C_I + C_c)R_I + g_{mII}R_I R_{II}C_c + R_z C_c$$

$$c = [R_I R_{II}(C_I C_{II} + C_c C_I + C_c C_{II}) + R_z C_c (R_I C_I + R_{II} C_{II})]$$

$$d = R_I R_{II} R_z C_I C_{II} C_c$$

<sup>†</sup> W.J. Parrish, "An Ion Implanted CMOS Amplifier for High Performance Active Filters", Ph.D. Dissertation, 1976, Univ. of CA., Santa Barbara.  
CMOS Analog Circuit Design © P.E. Allen - 2005

## Use of Nulling Resistor to Eliminate the RHP - Continued

If  $R_z$  is assumed to be less than  $R_I$  or  $R_{II}$  and the poles widely spaced, then the roots of the above transfer function can be approximated as

$$p_1 \cong \frac{-1}{(1 + g_{mII}R_{II})R_I C_c} \cong \frac{-1}{g_{mII}R_{II}R_I C_c}$$

$$p_2 \cong \frac{-g_{mII}C_c}{C_I C_{II} + C_c C_I + C_c C_{II}} \cong \frac{-g_{mII}}{C_{II}}$$

$$p_4 = \frac{-1}{R_z C_I}$$

and

$$z_1 = \frac{1}{C_c(1/g_{mII} - R_z)}$$

Note that the zero can be placed anywhere on the real axis.

### Conceptual Illustration of the Nulling Resistor Approach

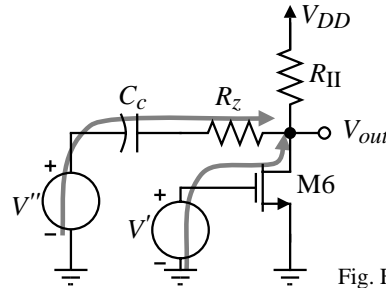

Fig. Fig. 430-05

The output voltage,  $V_{out}$ , can be written as

$$V_{out} = \frac{-g_{m6}R_{II}\left(R_z + \frac{1}{sC_c}\right)}{R_{II} + R_z + \frac{1}{sC_c}} V' + \frac{R_{II}}{R_{II} + R_z + \frac{1}{sC_c}} V'' = \frac{-R_{II}\left[g_{m6}R_z + \frac{g_{m6}}{sC_c} - 1\right]}{R_{II} + R_z + \frac{1}{sC_c}} V$$

when  $V = V' = V''$ .

Setting the numerator equal to zero and assuming  $g_{m6} = g_{mII}$  gives,

$$z_1 = \frac{1}{C_c(1/g_{mII} - R_z)}$$

### A Design Procedure that Allows the RHP Zero to Cancel the Output Pole, $p_2$

We desire that  $z_1 = p_2$  in terms of the previous notation.

Therefore,

$$\frac{1}{C_c(1/g_{mII} - R_z)} = \frac{-g_{mII}}{C_{II}}$$

The value of  $R_z$  can be found as

$$R_z = \left(\frac{C_c + C_{II}}{C_c}\right) (1/g_{mII})$$

With  $p_2$  canceled, the remaining roots are  $p_1$  and  $p_4$  (the pole due to  $R_z$ ). For unity-gain stability, all that is required is that

$$|p_4| > A_v(0)|p_1| = \frac{A_v(0)}{g_{mII}R_{II}R_I C_c} = \frac{g_{mI}}{C_c}$$

and  $(1/R_z C_I) > (g_{mI}/C_c) = GB$

Substituting  $R_z$  into the above inequality and assuming  $C_{II} \gg C_c$  results in

$$C_c > \sqrt{\frac{g_{mI}}{g_{mII}}} C_I C_{II}$$

This procedure gives excellent stability for a fixed value of  $C_{II}$  ( $\approx C_L$ ).

Unfortunately, as  $C_L$  changes,  $p_2$  changes and the zero must be readjusted to cancel  $p_2$ .

### Increasing the Magnitude of the Output Pole<sup>†</sup>

The magnitude of the output pole,  $p_2$ , can be increased by introducing gain in the Miller capacitor feedback path. For example,

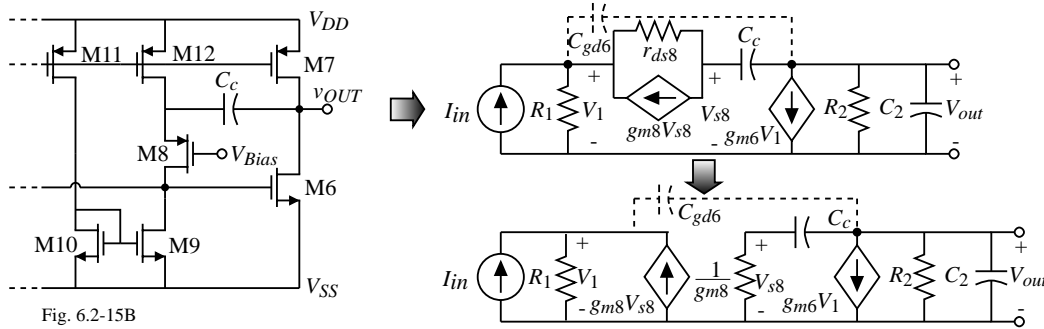

Fig. 6.2-15B

The resistors  $R_1$  and  $R_2$  are defined as

$$R_1 = \frac{1}{g_{ds2} + g_{ds4} + g_{ds9}} \quad \text{and} \quad R_2 = \frac{1}{g_{ds6} + g_{ds7}}$$

where transistors M2 and M4 are the output transistors of the first stage.

Nodal equations:

$$I_{in} = G_1 V_1 - g_{m8} V_{s8} = G_1 V_1 - \left( \frac{g_{m8} s C_c}{g_{m8} + s C_c} \right) V_{out} \quad \text{and} \quad 0 = g_{m6} V_1 + \left[ G_2 + s C_2 + \frac{g_{m8} s C_c}{g_{m8} + s C_c} \right] V_{out}$$

<sup>†</sup> B.K. Ahuja, "An Improved Frequency Compensation Technique for CMOS Operational Amplifiers," *IEEE J. of Solid-State Circuits*, Vol. SC-18, No. 6 (Dec. 1983) pp. 629-633.

### Increasing the Magnitude of the Output Pole - Continued

Solving for the transfer function  $V_{out}/I_{in}$  gives,

$$\frac{V_{out}}{I_{in}} = \left( \frac{-g_{m6}}{G_1 G_2} \right) \left[ \frac{\left( 1 + \frac{s C_c}{g_{m8}} \right)}{1 + s \left[ \frac{C_c}{g_{m8}} + \frac{C_2}{G_2} + \frac{C_c}{G_2} + \frac{g_{m6} C_c}{G_1 G_2} \right] + s^2 \left( \frac{C_c C_2}{g_{m8} G_2} \right)} \right]$$

Using the approximate method of solving for the roots of the denominator gives

$$p_1 = \frac{-1}{\frac{C_c}{g_{m8}} + \frac{C_2}{G_2} + \frac{C_c}{G_2} + \frac{g_{m6} C_c}{G_1 G_2}} \approx \frac{-6}{g_{m6} r_{ds}^2 C_c}$$

$$\text{and} \quad p_2 \approx \frac{-\frac{g_{m6} r_{ds}^2 C_c}{6}}{\frac{C_c C_2}{g_{m8} G_2}} = \frac{g_{m8} r_{ds}^2 G_2}{6} \left( \frac{g_{m6}}{C_2} \right) = \left( \frac{g_{m8} r_{ds}}{3} \right) |p_2'|$$

where all the various channel resistance have been assumed to equal  $r_{ds}$  and  $p_2'$  is the output pole for normal Miller compensation.

Result:

Dominant pole is approximately the same and the output pole is increased by  $\approx g_m r_{ds}$ .

### Increasing the Magnitude of the Output Pole - Continued

In addition there is a LHP zero at  $-g_{m8}/sC_c$  and a RHP zero due to  $C_{gd6}$  (shown dashed in the model on Page 6.2-20) at  $g_{m6}/C_{gd6}$ .

Roots are:

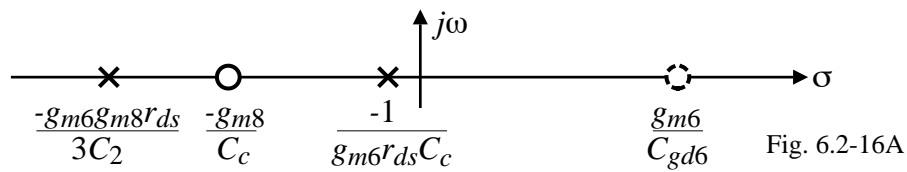

### Concept Behind the Increasing of the Magnitude of the Output Pole

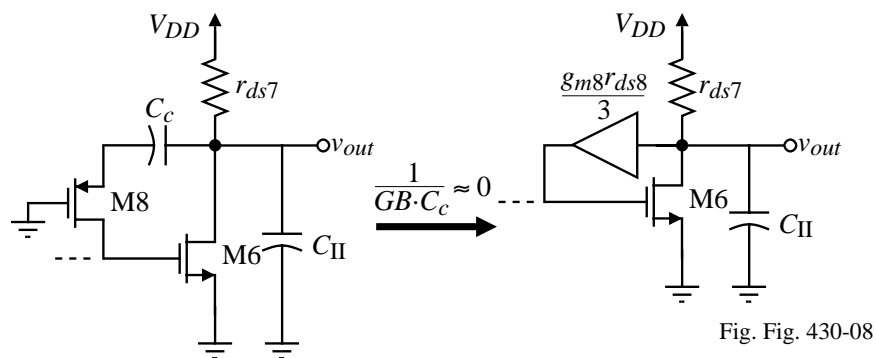

$$R_{out} = r_{ds7} \parallel \left( \frac{3}{g_{m6}g_{m8}r_{ds8}} \right) \approx \frac{3}{g_{m6}g_{m8}r_{ds8}}$$

Therefore, the output pole is approximately,

$$|p_2| \approx \frac{g_{m6}g_{m8}r_{ds8}}{3C_{II}}$$

### Identification of Poles from a Schematic

- 1.) Most poles are equal to the reciprocal product of the resistance from a node to ground and the capacitance connected to that node.
- 2.) Exceptions (generally due to feedback):
  - a.) Negative feedback:

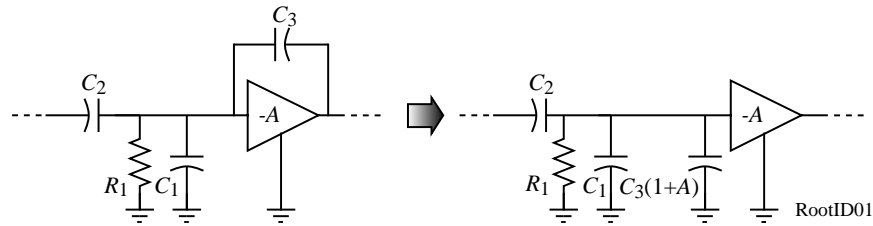

- 
- b.) Positive feedback ( $A < 1$ ):

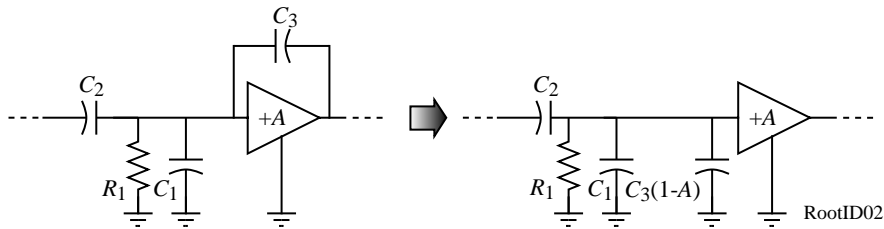

### Identification of Zeros from a Schematic

- 1.) Zeros arise from poles in the feedback path.

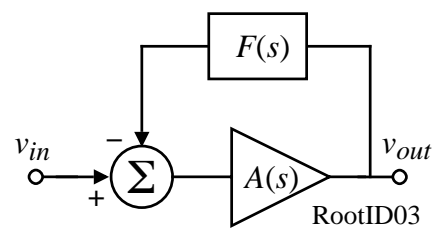

$$\text{If } F(s) = \frac{1}{\frac{s}{p_1} + 1}, \text{ then } \frac{V_{out}}{V_{in}} = \frac{A(s)}{1 + A(s)F(s)} = \frac{A(s)}{1 + A(s)\frac{1}{\frac{s}{p_1} + 1}} = \frac{A(s)\left(\frac{s}{p_1} + 1\right)}{\frac{s}{p_1} + 1 + A(s)}$$

- 
- 2.) Zeros are also created by two paths from the input to the output and one of more of the paths is frequency dependent.

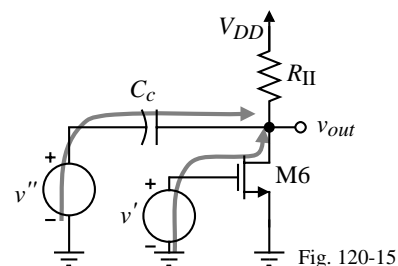

### Feedforward Compensation

Use two parallel paths to achieve a LHP zero for lead compensation purposes.

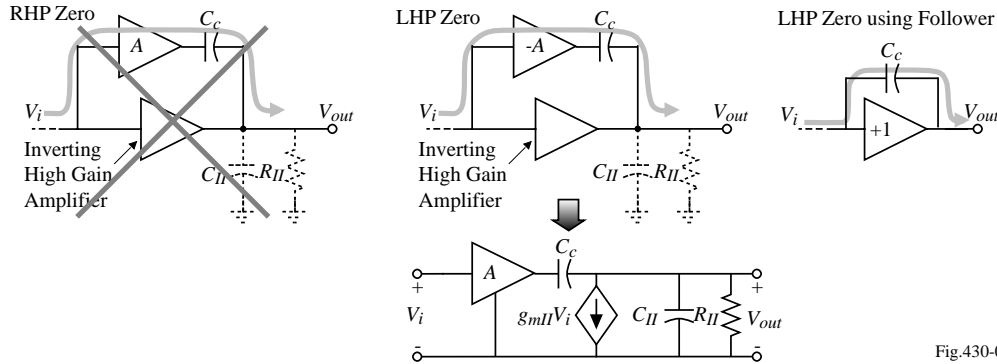

Fig.430-09

$$\frac{V_{out}(s)}{V_{in}(s)} = \frac{AC_c}{C_c + C_{II}} \left( \frac{s + g_{mII}/AC_c}{s + 1/[R_{II}(C_c + C_{II})]} \right)$$

To use the LHP zero for compensation, a compromise must be observed.

- Placing the zero below  $GB$  will lead to boosting of the loop gain that could deteriorate the phase margin.
- Placing the zero above  $GB$  will have less influence on the leading phase caused by the zero.

Note that a source follower is a good candidate for the use of feedforward compensation.

### Self-Compensated Op Amps

*Self compensation* occurs when the load capacitor is the compensation capacitor (can never be unstable for resistive feedback)

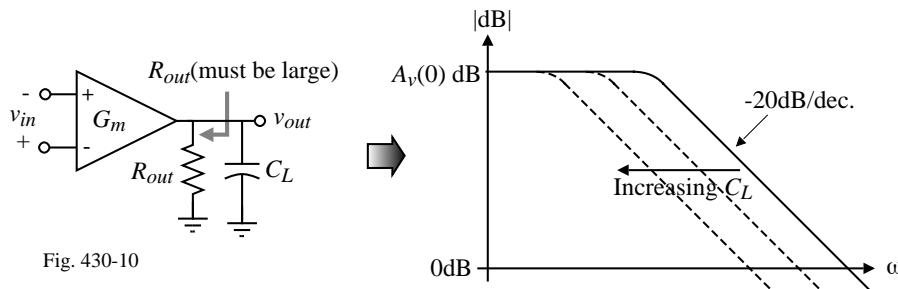

Fig. 430-10

Voltage gain:

$$\frac{v_{out}}{v_{in}} = A_v(0) = G_m R_{out}$$

Dominant pole:

$$p_1 = \frac{-1}{R_{out} C_L}$$

Unity-gainbandwidth:

$$GB = A_v(0) \cdot |p_1| = \frac{G_m}{C_L}$$

Stability:

Large load capacitors simply reduce  $GB$  but the phase is still  $90^\circ$  at  $GB$ .

### Slew Rate of a Two-Stage CMOS Op Amp

Remember that slew rate occurs when currents flowing in a capacitor become limited and is given as

$$I_{lim} = C \frac{dv_C}{dt} \text{ where } v_C \text{ is the voltage across the capacitor } C.$$

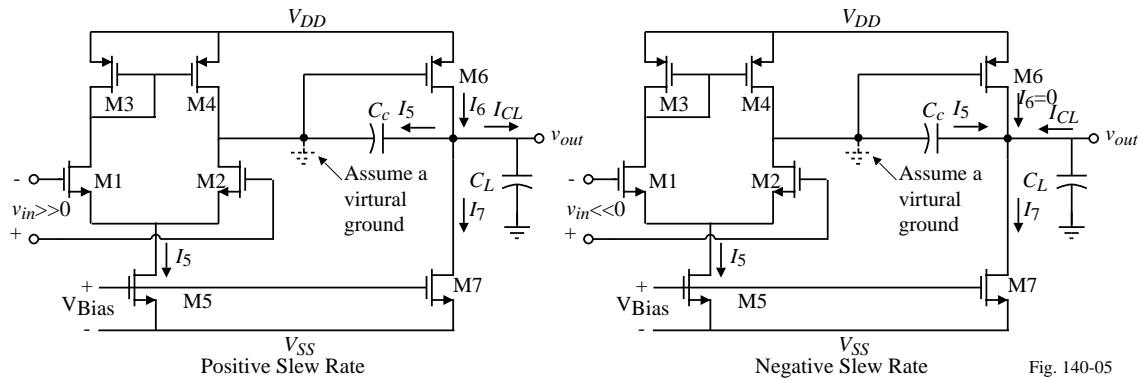

Fig. 140-05

$$SR^+ = \min \left[ \frac{I_5}{C_c}, \frac{I_6 - I_5 - I_7}{C_L} \right] = \frac{I_5}{C_c} \text{ because } I_6 \gg I_5 \quad SR^- = \min \left[ \frac{I_5}{C_c}, \frac{I_7 - I_5}{C_L} \right] = \frac{I_5}{C_c} \text{ if } I_7 \gg I_5.$$

Therefore, if  $C_L$  is not too large and if  $I_7$  is significantly greater than  $I_5$ , then the slew rate of the two-stage op amp should be,

$$SR = \frac{I_5}{C_c}$$

## SECTION 6.3 - TWO-STAGE OP AMP DESIGN

### Unbuffered, Two-Stage CMOS Op Amp

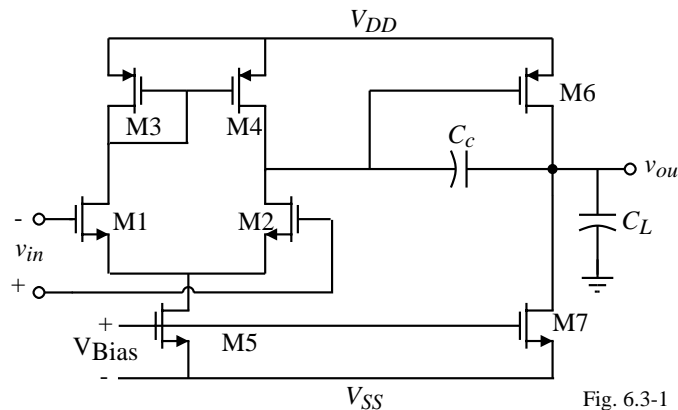

Fig. 6.3-1

Notation:

$$S_i = \frac{W_i}{L_i} = W/L \text{ of the } i\text{th transistor}$$

### DC Balance Conditions for the Two-Stage Op Amp

For best performance, keep all transistors in saturation.

M4 is the only transistor that cannot be forced into saturation by internal connections or external voltages.

Therefore, we develop conditions to force M4 to be in saturation.

1.) First *assume* that  $V_{SG4} = V_{SG6}$ . This will cause “proper mirroring” in the M3-M4 mirror. Also, the gate and drain of M4 are at the same potential so that M4 is “guaranteed” to be in saturation.

2.) If  $V_{SG4} = V_{SG6}$ , then  $I_6 = \left(\frac{S_6}{S_4}\right)I_4$

3.) However,  $I_7 = \left(\frac{S_7}{S_5}\right)I_5 = \left(\frac{S_7}{S_5}\right)(2I_4)$

4.) For balance,  $I_6$  must equal  $I_7 \Rightarrow \boxed{\frac{S_6}{S_4} = \frac{2S_7}{S_5}}$  called the “balance conditions”

5.) So if the balance conditions are satisfied, then  $V_{DG4} = 0$  and M4 is saturated.

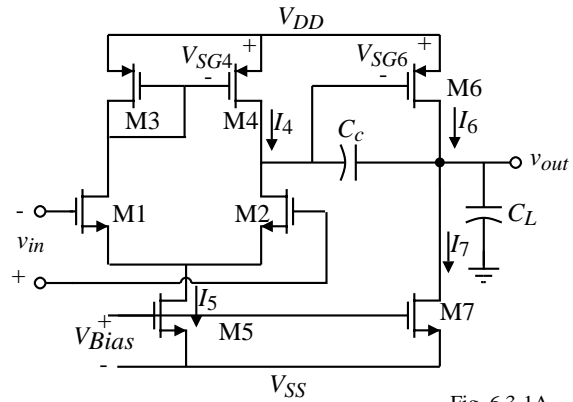

Fig. 6.3-1A

### Design Relationships for the Two-Stage Op Amp

Slew rate  $SR = \frac{I_5}{C_c}$  (Assuming  $I_7 \gg I_5$  and  $C_L > C_c$ )

First-stage gain  $A_{v1} = \frac{g_{m1}}{g_{ds2} + g_{ds4}} = \frac{2g_{m1}}{I_5(\lambda_2 + \lambda_4)}$

Second-stage gain  $A_{v2} = \frac{g_{m6}}{g_{ds6} + g_{ds7}} = \frac{g_{m6}}{I_6(\lambda_6 + \lambda_7)}$

Gain-bandwidth  $GB = \frac{g_{m1}}{C_c}$

Output pole  $p_2 = \frac{-g_{m6}}{C_L}$

RHP zero  $z_1 = \frac{g_{m6}}{C_c}$

60° phase margin requires that  $g_{m6} = 2.2g_{m2}(C_L/C_c)$  if all other roots are  $\geq 10GB$ .

Positive ICMR  $V_{in(max)} = V_{DD} - \sqrt{\frac{I_5}{\beta_3}} - |V_{T03}|_{(max)} + V_{T1(min)}$

Negative ICMR  $V_{in(min)} = V_{SS} + \sqrt{\frac{I_5}{\beta_1}} + V_{T1(max)} + V_{DS5(sat)}$

### Op Amp Specifications

The following design procedure assumes that specifications for the following parameters are given.

1. Gain at dc,  $A_v(0)$
2. Gain-bandwidth,  $GB$
3. Phase margin (or settling time)
4. Input common-mode range, ICMR
5. Load Capacitance,  $C_L$
6. Slew-rate,  $SR$
7. Output voltage swing
8. Power dissipation,  $P_{diss}$

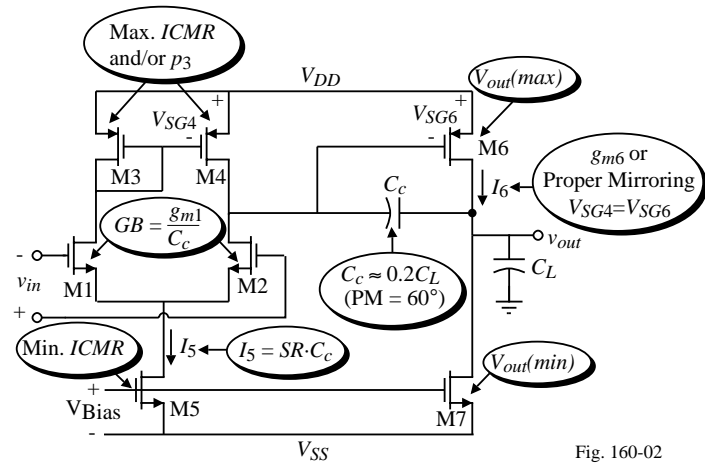

Fig. 160-02

### Unbuffered Op Amp Design Procedure

This design procedure assumes that the gain at dc ( $A_v$ ), unity gain bandwidth ( $GB$ ), input common mode range ( $V_{in}(\min)$  and  $V_{in}(\max)$ ), load capacitance ( $C_L$ ), slew rate ( $SR$ ), settling time ( $T_s$ ), output voltage swing ( $V_{out}(\max)$  and  $V_{out}(\min)$ ), and power dissipation ( $P_{diss}$ ) are given. Choose the smallest device length which will keep the channel modulation parameter constant and give good matching for current mirrors.

1. From the desired phase margin, choose the minimum value for  $C_c$ , i.e. for a  $60^\circ$  phase margin we use the following relationship. This assumes that  $z \geq 10GB$ .

$$C_c > 0.22C_L$$

2. Determine the minimum value for the “tail current” ( $I_5$ ) from the largest of the two values.

$$I_5 = SR \cdot C_c \quad \text{or} \quad I_5 \approx 10 \left( \frac{V_{DD} + |V_{SS}|}{2 \cdot T_s} \right)$$

3. Design for  $S_3$  from the maximum input voltage specification.

$$S_3 = \frac{I_5}{K'_3 [V_{DD} - V_{in}(\max) - |V_{T03}(\max) + V_{T1}(\min)]^2}$$

4. Verify that the pole of M3 due to  $C_{gs3}$  and  $C_{gs4}$  ( $= 0.67W_3L_3C_{ox}$ ) will not be dominant by assuming it to be greater than  $10GB$

$$\frac{gm_3}{2C_{gs3}} > 10GB.$$

**Unbuffered Op Amp Design Procedure - Continued**

5. Design for  $S_1$  ( $S_2$ ) to achieve the desired  $GB$ .

$$g_{m1} = GB \cdot C_c \rightarrow S_2 = \frac{g_{m1}^2}{K'_1 I_5}$$

6. Design for  $S_5$  from the minimum input voltage. First calculate  $V_{DS5}(\text{sat})$  then find  $S_5$ .

$$V_{DS5}(\text{sat}) = V_{in}(\text{min}) - V_{SS} - \sqrt{\frac{I_5}{\beta_1}} - V_{T1}(\text{max}) \geq 100 \text{ mV} \rightarrow S_5 = \frac{2I_5}{K'_5 [V_{DS5}(\text{sat})]^2}$$

7. Find  $S_6$  by letting the second pole ( $p_2$ ) be equal to 2.2 times  $GB$  and assuming that  $V_{SG4} = V_{SG6}$ .

$$g_{m6} = 2.2g_{m2}(C_L/C_c) \quad \text{and} \quad \frac{g_{m6}}{g_{m4}} = \frac{\sqrt{2K_P'S_6I_6}}{\sqrt{2K_P'S_4I_4}} = \sqrt{\frac{S_6I_6}{S_4I_4}} = \frac{S_6}{S_4} \rightarrow S_6 = \frac{g_{m6}}{g_{m4}}S_4$$

8. Calculate  $I_6$  from

$$I_6 = \frac{g_{m6}^2}{2K'_6S_6}$$

Check to make sure that  $S_6$  satisfies the  $V_{out}(\text{max})$  requirement and adjust as necessary.

9. Design  $S_7$  to achieve the desired current ratios between  $I_5$  and  $I_6$ .

$$S_7 = (I_6/I_5)S_5 \quad (\text{Check the minimum output voltage requirements})$$

**Unbuffered Op Amp Design Procedure - Continued**

10. Check gain and power dissipation specifications.

$$A_v = \frac{2g_{m2}g_{m6}}{I_5(\lambda_2 + \lambda_4)I_6(\lambda_6 + \lambda_7)} \quad P_{diss} = (I_5 + I_6)(V_{DD} + |V_{SS}|)$$

11. If the gain specification is not met, then the currents,  $I_5$  and  $I_6$ , can be decreased or the W/L ratios of M2 and/or M6 increased. The previous calculations must be rechecked to insure that they are satisfied. If the power dissipation is too high, then one can only reduce the currents  $I_5$  and  $I_6$ . Reduction of currents will probably necessitate increase of some of the W/L ratios in order to satisfy input and output swings.

12. Simulate the circuit to check to see that all specifications are met.

**Example 6.3-1 - Design of a Two-Stage Op Amp**

Using the material and device parameters given in Tables 3.1-1 and 3.1-2, design an amplifier similar to that shown in Fig. 6.3-1 that meets the following specifications. Assume the channel length is to be  $1\mu\text{m}$  and the load capacitor is  $C_L = 10\text{pF}$ .

$$A_V > 3000\text{V/V}$$

$$V_{DD} = 2.5\text{V}$$

$$V_{SS} = -2.5\text{V}$$

$$GB = 5\text{MHz}$$

$$SR > 10\text{V}/\mu\text{s}$$

$$60^\circ \text{ phase margin}$$

$$V_{out} \text{ range} = \pm 2\text{V}$$

$$ICMR = -1 \text{ to } 2\text{V}$$

$$P_{diss} \leq 2\text{mW}$$

**Solution**

1.) The first step is to calculate the minimum value of the compensation capacitor  $C_c$ ,

$$C_c > (2.2/10)(10 \text{ pF}) = 2.2 \text{ pF}$$

2.) Choose  $C_c$  as 3pF. Using the slew-rate specification and  $C_c$  calculate  $I_5$ .

$$I_5 = (3 \times 10^{-12})(10 \times 10^6) = 30 \mu\text{A}$$

3.) Next calculate  $(W/L)_3$  using ICMR requirements.

$$(W/L)_3 = \frac{30 \times 10^{-6}}{(50 \times 10^{-6})[2.5 - 2 - .85 + 0.55]^2} = 15 \quad \rightarrow \quad \boxed{(W/L)_3 = (W/L)_4 = 15}$$

**Example 6.3-1 - Continued**

4.) Now we can check the value of the mirror pole,  $p_3$ , to make sure that it is in fact greater than  $10GB$ . Assume the  $C_{ox} = 0.4\text{fF}/\mu\text{m}^2$ . The mirror pole can be found as

$$p_3 \approx \frac{-g_{m3}}{2C_{gs3}} = \frac{-\sqrt{2K'_p S_3 I_3}}{2(0.667)W_3 L_3 C_{ox}} = -2.81 \times 10^9 (\text{rads/sec})$$

or 448 MHz. Thus,  $p_3$ , is not of concern in this design because  $p_3 \gg 10GB$ .

5.) The next step in the design is to calculate  $g_{m1}$  to get

$$g_{m1} = (5 \times 10^6)(2\pi)(3 \times 10^{-12}) = 94.25 \mu\text{S}$$

Therefore,  $(W/L)_1$  is

$$(W/L)_1 = (W/L)_2 = \frac{g_{m1}^2}{2K'_n I_1} = \frac{(94.25)^2}{2 \cdot 110 \cdot 15} = 2.79 \approx 3.0 \Rightarrow \boxed{(W/L)_1 = (W/L)_2 = 3}$$

6.) Next calculate  $V_{DS5}$ ,

$$V_{DS5} = (-1) - (-2.5) - \sqrt{\frac{30 \times 10^{-6}}{110 \times 10^{-6} \cdot 3} - .85} = 0.35\text{V}$$

Using  $V_{DS5}$  calculate  $(W/L)_5$  from the saturation relationship.

$$(W/L)_5 = \frac{2(30 \times 10^{-6})}{(110 \times 10^{-6})(0.35)^2} = 4.49 \approx 4.5 \quad \rightarrow \quad \boxed{(W/L)_5 = 4.5}$$

**Example 6.3-1 - Continued**

7.) For 60° phase margin, we know that

$$g_{m6} \geq 10g_{m1} \geq 942.5\mu\text{S}$$

Assuming that  $g_{m6} = 942.5\mu\text{S}$  and knowing that  $g_{m4} = 150\mu\text{S}$ , we calculate  $(W/L)_6$  as

$$(W/L)_6 = 15 \frac{942.5 \times 10^{-6}}{(150 \times 10^{-6})} = 94.25 \approx 94$$

8.) Calculate  $I_6$  using the small-signal  $g_m$  expression:

$$I_6 = \frac{(942.5 \times 10^{-6})^2}{(2)(50 \times 10^{-6})(94.25)} = 94.5\mu\text{A} \approx 95\mu\text{A}$$

If we calculate  $(W/L)_6$  based on  $V_{out}(\text{max})$ , the value is approximately 15. Since 94 exceeds the specification and maintains better phase margin, we will stay with  $(W/L)_6 = 94$  and  $I_6 = 95\mu\text{A}$ .

With  $I_6 = 95\mu\text{A}$  the power dissipation is

$$P_{diss} = 5\text{V} \cdot (30\mu\text{A} + 95\mu\text{A}) = 0.625\text{mW}.$$

**Example 6.3-1 - Continued**

9.) Finally, calculate  $(W/L)_7$

$$(W/L)_7 = 4.5 \left( \frac{95 \times 10^{-6}}{30 \times 10^{-6}} \right) = 14.25 \approx 14 \quad \rightarrow \quad \boxed{(W/L)_7 = 14}$$

Let us check the  $V_{out}(\text{min})$  specification although the W/L of M7 is so large that this is probably not necessary. The value of  $V_{out}(\text{min})$  is

$$V_{out}(\text{min}) = V_{DS7}(\text{sat}) = \sqrt{\frac{2 \cdot 95}{110 \cdot 14}} = 0.351\text{V}$$

which is less than required. At this point, the first-cut design is complete.

10.) Now check to see that the gain specification has been met

$$A_v = \frac{(92.45 \times 10^{-6})(942.5 \times 10^{-6})}{15 \times 10^{-6}(0.04 + .05)95 \times 10^{-6}(0.04 + .05)} = 7,697\text{V/V}$$

which exceeds the specifications by a factor of two. An easy way to achieve more gain would be to increase the W and L values by a factor of two which because of the decreased value of  $\lambda$  would multiply the above gain by a factor of 20.

11.) The final step in the hand design is to establish true electrical widths and lengths based upon  $\Delta L$  and  $\Delta W$  variations. In this example  $\Delta L$  will be due to lateral diffusion only. Unless otherwise noted,  $\Delta W$  will not be taken into account. All dimensions will be rounded to integer values. Assume that  $\Delta L = 0.2\mu\text{m}$ . Therefore, we have

**Example 6.3-1 - Continued**

$$W_1 = W_2 = 3(1 - 0.4) = 1.8 \mu\text{m} \approx 2 \mu\text{m}$$

$$W_3 = W_4 = 15(1 - 0.4) = 9 \mu\text{m}$$

$$W_5 = 4.5(1 - 0.4) = 2.7 \mu\text{m} \approx 3 \mu\text{m}$$

$$W_6 = 94(1 - 0.4) = 56.4 \mu\text{m} \approx 56 \mu\text{m}$$

$$W_7 = 14(1 - 0.4) = 8.4 \approx 8 \mu\text{m}$$

The figure below shows the results of the first-cut design. The W/L ratios shown do not account for the lateral diffusion discussed above. The next phase requires simulation.

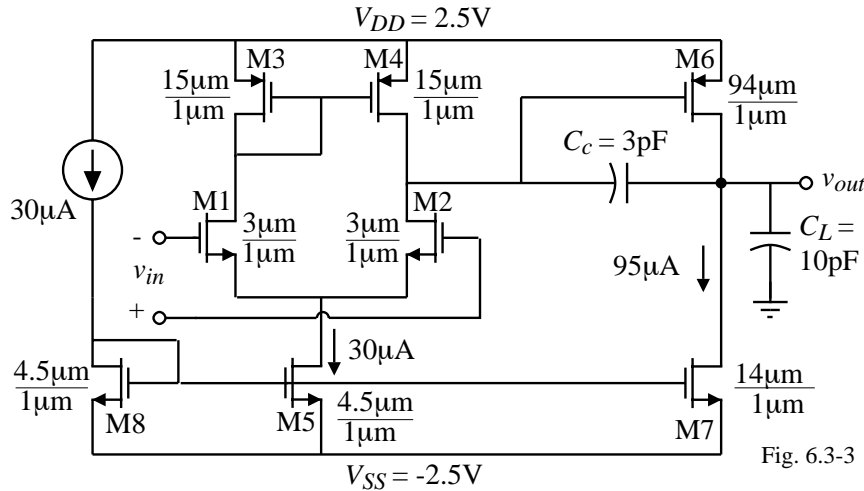

Fig. 6.3-3

**Incorporating the Nulling Resistor into the Miller Compensated Two-Stage Op Amp Circuit:**

Fig. 160-03

We saw earlier that the roots were:

$$p_1 = -\frac{g_{m2}}{A_v C_c} = -\frac{g_{m1}}{A_v C_c}$$

$$p_2 = -\frac{g_{m6}}{C_L}$$

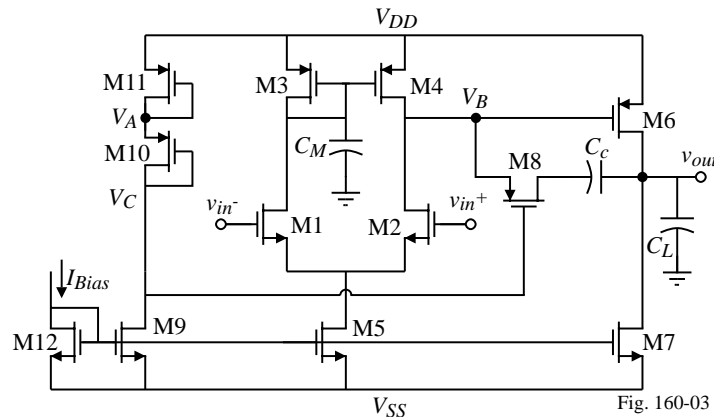
$$p_4 = -\frac{1}{R_z C_I}$$

$$z_1 = \frac{-1}{R_z C_c - C_c / g_{m6}}$$

where  $A_v = g_{m1} g_{m6} R_I R_{II}$ .

(Note that  $p_4$  is the pole resulting from the nulling resistor compensation technique.)

### **Design of the Nulling Resistor (M8)**

In order to place the zero on top of the second pole ( $p_2$ ), the following relationship must hold

$$R_z = \frac{1}{g_{m6}} \left( \frac{C_L + C_c}{C_c} \right) = \left( \frac{C_c + C_L}{C_c} \right) \frac{1}{\sqrt{2K'_p S_6 I_6}}$$

The resistor,  $R_z$ , is realized by the transistor M8 which is operating in the active region because the dc current through it is zero. Therefore,  $R_z$ , can be written as

$$R_z = \frac{\partial v_{DS8}}{\partial i_{D8}} \Big|_{V_{DS8}=0} = \frac{1}{K'_p S_8 (V_{SG8} - |V_{TP}|)}$$

The bias circuit is designed so that voltage  $V_A$  is equal to  $V_B$ .

$$\therefore |V_{GS10}| - |V_T| = |V_{GS8}| - |V_T| \Rightarrow V_{SG11} = V_{SG6} \quad \Rightarrow \left( \frac{W_{11}}{L_{11}} \right) = \left( \frac{I_{10}}{I_6} \right) \left( \frac{W_6}{L_6} \right)$$

In the saturation region

$$|V_{GS10}| - |V_T| = \sqrt{\frac{2(I_{10})}{K'_p (W_{10}/L_{10})}} = |V_{GS8}| - |V_T|$$

$$\therefore R_z = \frac{1}{K'_p S_8} \sqrt{\frac{K'_p S_{10}}{2I_{10}}} = \frac{1}{S_8} \sqrt{\frac{S_{10}}{2K'_p I_{10}}}$$

$$\text{Equating the two expressions for } R_z \text{ gives } \left( \frac{W_8}{L_8} \right) = \left( \frac{C_c}{C_L + C_c} \right) \sqrt{\frac{S_{10} S_6 I_6}{I_{10}}}$$

### **Example 6.3-2 - RHP Zero Compensation**

Use results of Ex. 6.3-1 and design compensation circuitry so that the RHP zero is moved from the RHP to the LHP and placed on top of the output pole  $p_2$ . Use device data given in Ex. 6.3-1.

#### **Solution**

The task at hand is the design of transistors M8, M9, M10, M11, and bias current  $I_{10}$ . The first step in this design is to establish the bias components. In order to set  $V_A$  equal to  $V_B$ , then  $V_{SG11}$  must equal  $V_{SG6}$ . Therefore,

$$S_{11} = (I_{11}/I_6) S_6$$

Choose  $I_{11} = I_{10} = I_9 = 15 \mu\text{A}$  which gives  $S_{11} = (15 \mu\text{A}/95 \mu\text{A}) 94 = 14.8 \approx 15$ .

The aspect ratio of M10 is essentially a free parameter, and will be set equal to 1. There must be sufficient supply voltage to support the sum of  $V_{SG11}$ ,  $V_{SG10}$ , and  $V_{DS9}$ . The ratio of  $I_{10}/I_5$  determines the  $(W/L)$  of M9. This ratio is

$$(W/L)_9 = (I_{10}/I_5)(W/L)_5 = (15/30)(4.5) = 2.25 \approx 2$$

Now  $(W/L)_8$  is determined to be

$$(W/L)_8 = \left( \frac{3\text{pF}}{3\text{pF} + 10\text{pF}} \right) \sqrt{\frac{1 \cdot 94 \cdot 95 \mu\text{A}}{15 \mu\text{A}}} = 5.63 \approx 6$$

**Example 6.3-2 - Continued**

It is worthwhile to check that the RHP zero has been moved on top of  $p_2$ . To do this, first calculate the value of  $R_z$ .  $V_{SG8}$  must first be determined. It is equal to  $V_{SG10}$ , which is

$$V_{SG10} = \sqrt{\frac{2I_{10}}{K'pS_{10}}} + |V_{TP}| = \sqrt{\frac{2 \cdot 15}{50 \cdot 1}} + 0.7 = 1.474\text{V}$$

Next determine  $R_z$ .

$$R_z = \frac{1}{K'pS_8(V_{SG10} - |V_{TP}|)} = \frac{10^6}{50 \cdot 5.63(1.474 - 0.7)} = 4.590\text{k}\Omega$$

The location of  $z_1$  is calculated as

$$z_1 = \frac{-1}{(4.590 \times 10^3)(3 \times 10^{-12}) - \frac{3 \times 10^{-12}}{942.5 \times 10^{-6}}} = -94.46 \times 10^6 \text{ rads/sec}$$

The output pole,  $p_2$ , is

$$p_2 = -\frac{942.5 \times 10^{-6}}{10 \times 10^{-12}} = -94.25 \times 10^6 \text{ rads/sec}$$

Thus, we see that for all practical purposes, the output pole is canceled by the zero that has been moved from the RHP to the LHP.

The results of this design are summarized below.

$$W_8 = 6 \mu\text{m} \quad W_9 = 2 \mu\text{m} \quad W_{10} = 1 \mu\text{m} \quad W_{11} = 15 \mu\text{m}$$

**An Alternate Form of Nulling Resistor**

To cancel  $p_2$ ,

$$z_1 = p_2 \rightarrow R_z = \frac{C_c + C_L}{g_{m6A} C_c} = \frac{1}{g_{m6B}}$$

Which gives

$$g_{m6B} = g_{m6A} \left( \frac{C_c}{C_c + C_L} \right)$$

In the previous example,

$$g_{m6A} = 942.5 \mu\text{S}, C_c = 3\text{pF}$$

and  $C_L = 10\text{pF}$ .

Choose  $I_{6B} = 10 \mu\text{A}$  to get

$$g_{m6B} = \frac{g_{m6A} C_c}{C_c + C_L} \rightarrow \sqrt{\frac{2K_P W_{6B} I_{6B}}{L_{6B}}} = \left( \frac{C_c}{C_c + C_L} \right) \sqrt{\frac{2K_P W_{6A} I_{D6}}{L_{6A}}}$$

or

$$\frac{W_{6B}}{L_{6B}} = \left( \frac{3}{13} \right)^2 \frac{I_{6A}}{I_{6B}} \frac{W_{6A}}{L_{6A}} = \left( \frac{3}{13} \right)^2 \left( \frac{95}{10} \right) (94) = 47.6 \rightarrow W_{6B} = 48 \mu\text{m}$$

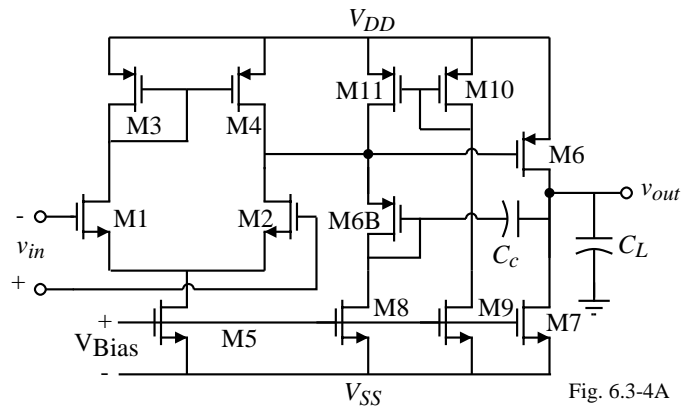

Fig. 6.3-4A

**Programmability of the Two-Stage Op Amp**

The following relationships depend on the bias current,  $I_{bias}$ , in the following manner and allow for programmability after fabrication.

$$A_v(0) = g_{mI} g_{mII} R_I R_{II} \propto \frac{1}{I_{Bias}}$$

$$GB = \frac{g_{mI}}{C_c} \propto \sqrt{I_{Bias}}$$

$$P_{diss} = (V_{DD} + |V_{SS}|)(1 + K_1 + K_2)I_{Bias} \propto I_{bias}$$

$$SR = \frac{K_1 I_{Bias}}{C_c} \propto I_{Bias}$$

$$R_{out} = \frac{1}{2\lambda K_2 I_{Bias}} \propto \frac{1}{I_{Bias}}$$

$$|p_1| = \frac{1}{g_{mII} R_I R_{II} C_c} \propto \frac{I_{Bias}^2}{\sqrt{I_{Bias}}} \propto I_{Bias}^{1.5}$$

$$|z| = \frac{g_{mII}}{C_c} \propto \sqrt{I_{Bias}}$$

Illustration of the  $I_{bias}$  dependence →

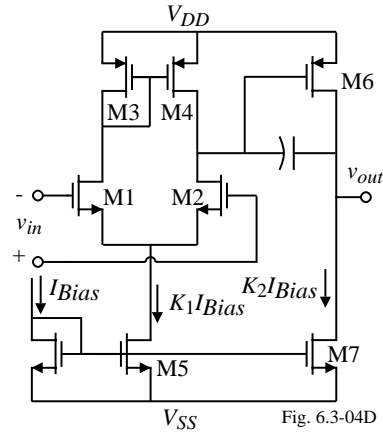

Fig. 6.3-04D

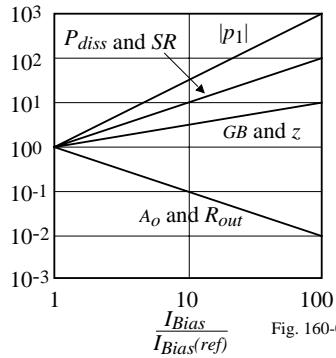

Fig. 160-05

**Simulation of the Electrical Design**

$$\text{Area of source or drain} = AS = AD = W[L1 + L2 + L3]$$

where

L1 = Minimum allowable distance between the contact in the S/D and the polysilicon ( $5\mu\text{m}$ )

L2 = Width of a minimum size contact ( $5\mu\text{m}$ )

L3 = Minimum allowable distance from contact in S/D to edge of S/D ( $5\mu\text{m}$ )

$$\therefore AS = AD = W \times 15\mu\text{m}$$

$$\text{Perimeter of the source or drain} = PD = PS = 2W + 2(L1 + L2 + L3)$$

$$\therefore PD = PS = 2W + 30\mu\text{m}$$

Illustration:

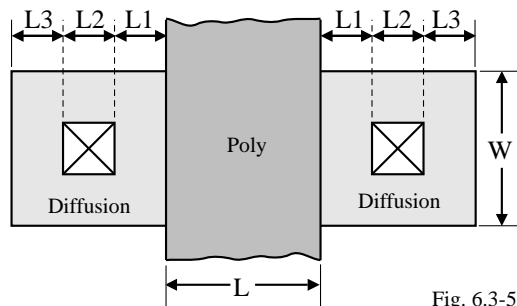

Fig. 6.3-5

### 5-to-1 Current Mirror with Different Physical Performances

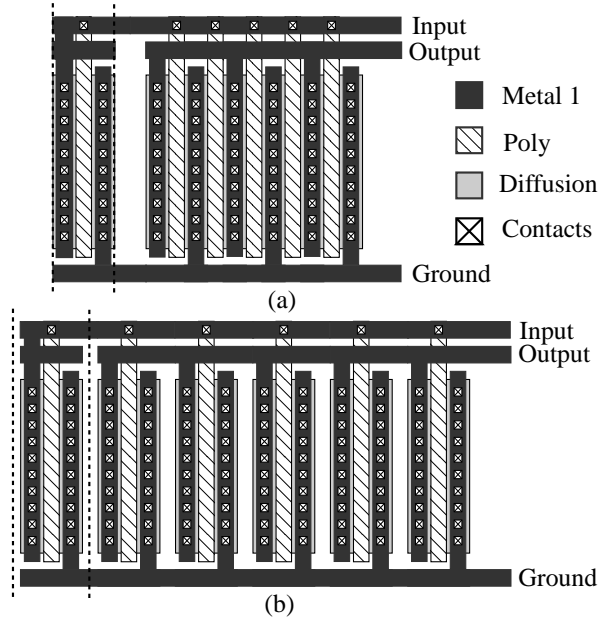

Figure 6.3-6 The layout of a 5-to-1 current mirror. (a) Layout which minimizes area at the sacrifice of matching. (b) Layout which optimizes matching.

### 1-to-1.5 Transistor Matching

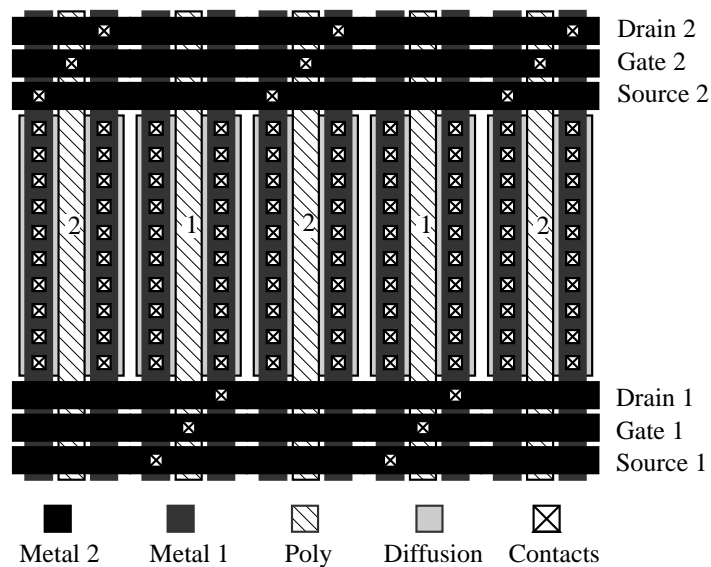

Figure 6.3-7 The layout of two transistors with a 1.5 to 1 matching using centroid geometry to improve matching.

### Reduction of Parasitics

The major objective of good layout is to minimize the parasitics that influence the design. Typical parasitics include:

- Capacitors to ac ground
- Series resistance

Capacitive parasitics is minimized by minimizing area and maximizing the distance between the conductor and ac ground.

Resistance parasitics are minimized by using wide busses and keeping the bus length short.

For example:

At  $2\text{m}\Omega/\text{square}$ , a metal run of  $1000\mu\text{m}$  and  $2\mu\text{m}$  wide will have  $1\Omega$  of resistance.

At  $1\text{ mA}$  this amounts to a  $1\text{ mV}$  drop which could easily be greater than the least significant bit of an analog-digital converter. (For example, a 10 bit ADC with  $V_{REF} = 1\text{V}$  has an LSB of  $1\text{mV}$ )

### Technique for Reducing the Overlap Capacitance

Square Donut Transistor:

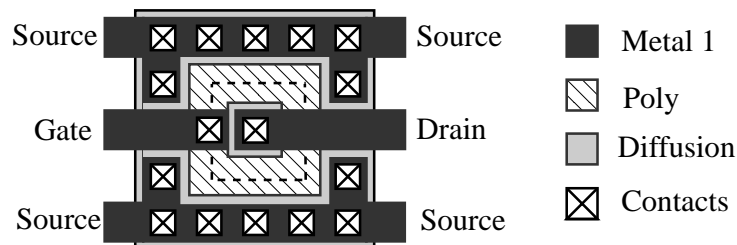

Figure 6.3-8 Reduction of  $C_{gd}$  by a donut shaped transistor.

Note: Can get more W/L in less area with the above geometry.

### Chip Voltage Bias Distribution Scheme

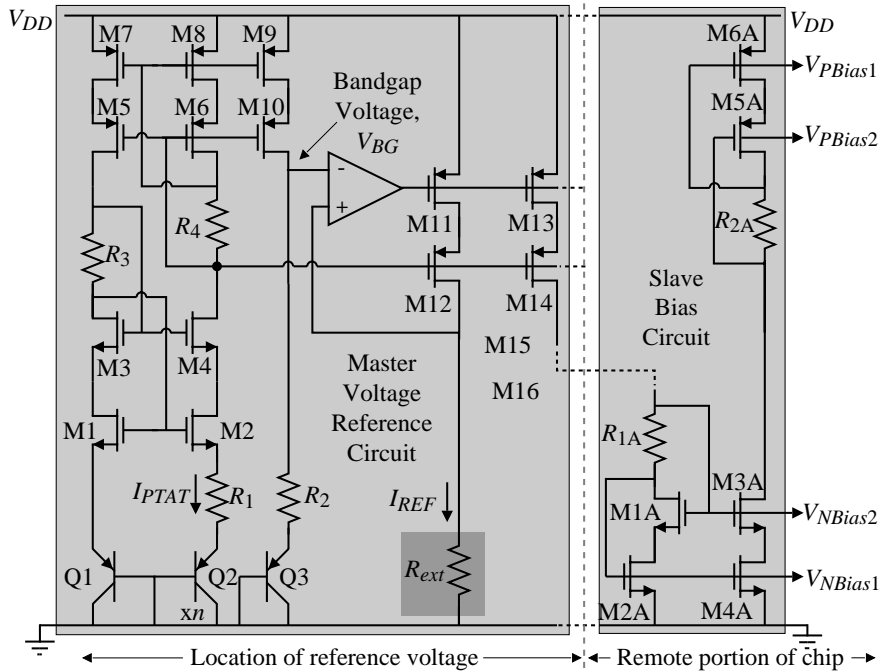

Figure 6.3-9 Generation of a reference voltage which is distributed on the chip as a current to slave bias circuits.

### SECTION 6.4 - PSRR OF THE TWO-STAGE OP AMP

#### What is PSRR?

$$PSRR = \frac{A_v(V_{dd}=0)}{A_{dd}(V_{in}=0)}$$

#### How do you calculate PSRR?

You could calculate  $A_v$  and  $A_{dd}$  and divide, however

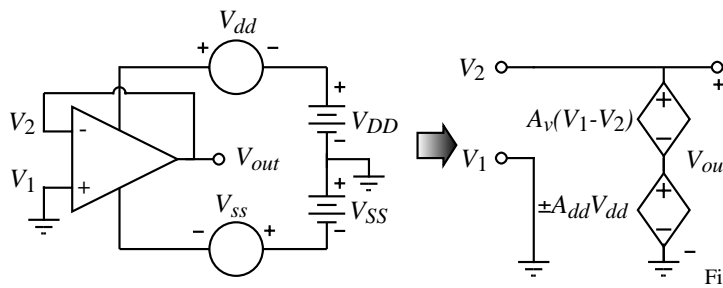
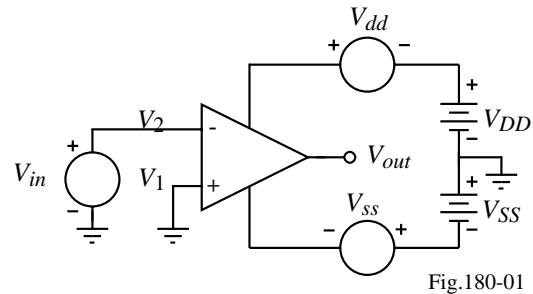

$$V_{out} = A_{dd}V_{dd} + A_v(V_1 - V_2) = A_{dd}V_{dd} - A_vV_{out} \rightarrow V_{out}(1 + A_v) = A_{dd}V_{dd}$$

$$\therefore \frac{V_{out}}{V_{dd}} = \frac{A_{dd}}{1 + A_v} \approx \frac{A_{dd}}{A_v} = \frac{1}{PSRR} \quad (\text{Good for frequencies up to } GB)$$

### Positive *PSRR* of the Two-Stage Op Amp

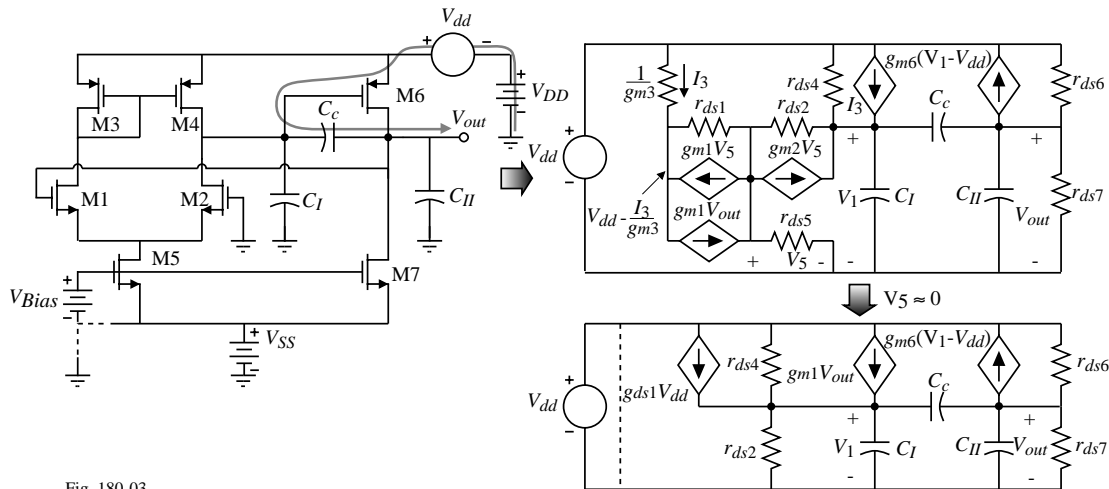

Fig. 180-03

The nodal equations are:

$$(g_{ds1} + g_{ds4})V_{dd} = (g_{ds2} + g_{ds4} + sC_c + sC_I)V_1 - (g_{m1} + sC_c)V_{out}$$

$$(g_{m6} + g_{ds6})V_{dd} = (g_{m6} - sC_c)V_1 + (g_{ds6} + g_{ds7} + sC_c + sC_{II})V_{out}$$

Using the generic notation the nodal equations are:

$$G_I V_{dd} = (G_I + sC_c + sC_I)V_1 - (g_{mI} + sC_c)V_{out}$$

$$(g_{mII} + g_{ds6})V_{dd} = (g_{mII} - sC_c)V_1 + (G_{II} + sC_c + sC_{II})V_{out}$$

where  $G_I = g_{ds1} + g_{ds4} = g_{ds2} + g_{ds4}$ ,  $G_{II} = g_{ds6} + g_{ds7}$ ,  $g_{mI} = g_{m1} = g_{m2}$  and  $g_{mII} = g_{m6}$

### Positive *PSRR* of the Two-Stage Op Amp - Continued

Using Cramer's rule to solve for the transfer function,  $V_{out}/V_{dd}$ , and inverting the transfer function gives the following result.

$$\frac{V_{dd}}{V_{out}} = \frac{s^2[C_c C_I + C_I C_{II} + C_{II} C_c] + s[G_I(C_c + C_{II}) + G_{II}(C_c + C_I) + C_c(g_{mII} - g_{mI})] + G_I G_{II} + g_{mI} g_{mII}}{s[C_c(g_{mII} + G_I + g_{ds6}) + C_I(g_{mII} + g_{ds6})] + G_I g_{ds6}}$$

We may solve for the approximate roots of numerator as

$$PSRR^+ = \frac{V_{dd}}{V_{out}} \approx \left( \frac{g_{mI} g_{mII}}{G_I g_{ds6}} \right) \left[ \frac{\left( \frac{sC_c}{g_{mI}} + 1 \right) \left( \frac{s(C_c C_I + C_I C_{II} + C_c C_{II})}{g_{mII} C_c} + 1 \right)}{\left( \frac{s g_{mII} C_c}{G_I g_{ds6}} + 1 \right)} \right]$$

where  $g_{mII} > g_{mI}$  and that all transconductances are larger than the channel conductances.

$$\therefore PSRR^+ = \frac{V_{dd}}{V_{out}} = \left( \frac{g_{mI} g_{mII}}{G_I g_{ds6}} \right) \left[ \frac{\left( \frac{sC_c}{g_{mI}} + 1 \right) \left( \frac{sC_{II}}{g_{mII}} + 1 \right)}{\frac{s g_{mII} C_c}{G_I g_{ds6}} + 1} \right] = \left( \frac{G_{II} A_{vo}}{g_{ds6}} \right) \frac{\left( \frac{s}{GB} + 1 \right) \left( \frac{s}{|p_2|} + 1 \right)}{\left( \frac{s G_{II} A_{vo}}{g_{ds6} GB} + 1 \right)}$$

**Positive PSRR of the Two-Stage Op Amp - Continued**

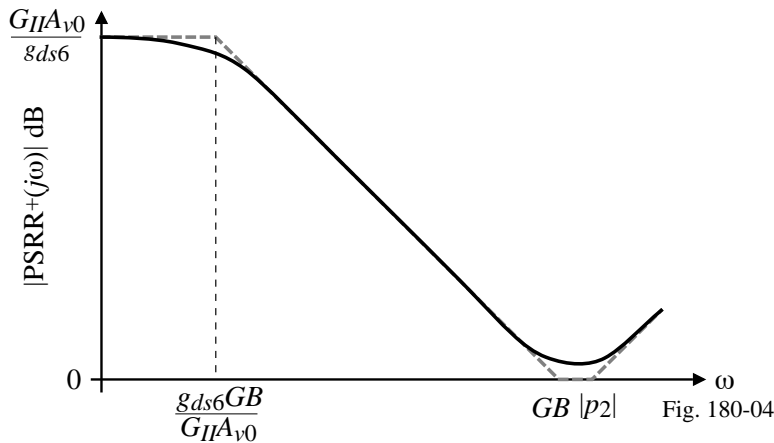

At approximately the dominant pole, the PSRR falls off with a -20dB/decade slope and degrades the higher frequency PSRR+ of the two-stage op amp.

Using the values of Example 6.3-1 we get:

$$PSRR^+(0) = 68.8\text{dB}, \quad z_1 = -5\text{MHz}, \quad z_2 = -15\text{MHz} \quad \text{and} \quad p_1 = -906\text{Hz}$$

**Concept of the PSRR+ for the Two-Stage Op Amp**

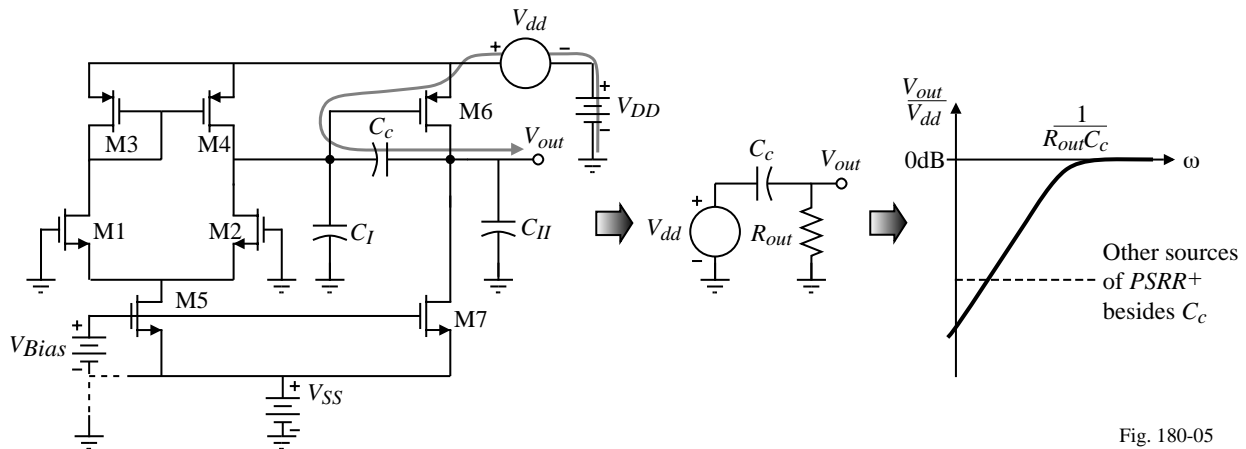

- 1.) The M7 current sink causes  $V_{SG6}$  to act like a battery.
- 2.) Therefore,  $V_{dd}$  couples from the source to gate of M6.
- 3.) The path to the output is through any capacitance from gate to drain of M6.

Conclusion:

The Miller capacitor  $C_c$  couples the positive power supply ripple directly to the output.

Must reduce or eliminate  $C_c$ .

### Negative $PSRR$ of the Two-Stage Op Amp with $V_{Bias}$ Grounded

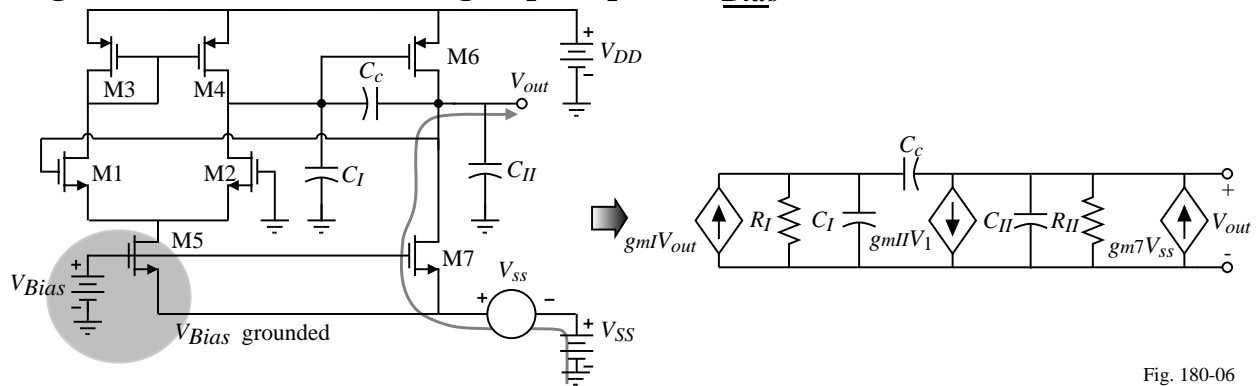

Fig. 180-06

Nodal equations for  $V_{Bias}$  grounded:

$$0 = (G_I + sC_c + sC_I)V_1 - (g_{mI} + sC_c)V_o$$

$$g_{m7}V_{ss} = (g_{mII} - sC_c)V_1 + (G_{II} + sC_c + sC_{II})V_o$$

Solving for  $V_{out}/V_{ss}$  and inverting gives

$$\frac{V_{ss}}{V_{out}} = \frac{s^2[C_c C_I + C_I C_{II} + C_{II} C_c] + s[G_I(C_c + C_{II}) + G_{II}(C_c + C_I) + C_c(g_{mII} - g_{mI})] + G_I G_{II} + g_{mI} g_{mII}}{[s(C_c + C_I) + G_I]g_{m7}}$$

### Negative $PSRR$ of the Two-Stage Op Amp with $V_{Bias}$ Grounded - Continued

Again using techniques described previously, we may solve for the approximate roots as

$$PSRR^- = \frac{V_{ss}}{V_{out}} \cong \left( \frac{g_{mI} g_{mII}}{G_I g_{m7}} \right) \left[ \frac{\left( \frac{sC_c}{g_{mI}} + 1 \right) \left( \frac{s(C_c C_I + C_I C_{II} + C_c C_{II})}{g_{mII} C_c} + 1 \right)}{\left( \frac{s(C_c + C_I)}{G_I} + 1 \right)} \right]$$

This equation can be rewritten approximately as

$$PSRR^- = \frac{V_{ss}}{V_{out}} \cong \left( \frac{g_{mI} g_{mII}}{G_I g_{m7}} \right) \left[ \frac{\left( \frac{sC_c}{g_{mI}} + 1 \right) \left( \frac{sC_{II}}{g_{mII}} + 1 \right)}{\left( \frac{sC_c}{G_I} + 1 \right)} \right] = \left( \frac{G_{II} A_{v0}}{g_{m7}} \right) \left[ \frac{\left( \frac{s}{GB} + 1 \right) \left( \frac{s}{|p_2|} + 1 \right)}{\left( \frac{s}{GB} \frac{g_{mI}}{G_I} + 1 \right)} \right]$$

Comments:

$PSRR^-$  zeros =  $PSRR^+$  zeros

DC gain  $\approx$  Second-stage gain,

$PSRR^-$  pole  $\approx$  (Second-stage gain) x ( $PSRR^+$  pole)

Assuming the values of Ex. 6.3-1 gives a gain of 23.7 dB and a pole -147 kHz. The dc value of  $PSRR^-$  is very poor for this case, however, this case can be avoided by correctly implementing  $V_{Bias}$  which we consider next.

### Negative $PSRR$ of the Two-Stage Op Amp with $V_{Bias}$ Connected to $V_{SS}$

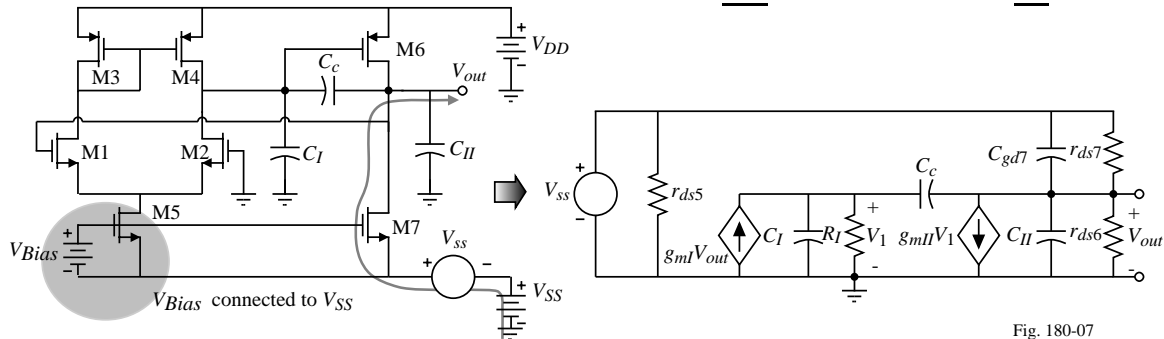

Fig. 180-07

If the value of  $V_{Bias}$  is independent of  $V_{SS}$ , then the model shown results. The nodal equations for this model are

$$0 = (G_I + sC_c + sC_I)V_1 - (g_{mI} + sC_c)V_{out}$$

and

$$(g_{ds7} + sC_{gd7})V_{ss} = (g_{mII} - sC_c)V_1 + (G_{II} + sC_c + sC_{II} + sC_{gd7})V_{out}$$

Again, solving for  $V_{out}/V_{ss}$  and inverting gives

$$\frac{V_{ss}}{V_{out}} = \frac{s^2[C_c C_I + C_I C_{II} + C_{II} C_c + C_I C_{gd7} + C_c C_{gd7}] + s[G_I(C_c + C_{II} + C_{gd7}) + G_{II}(C_c + C_I) + C_c(g_{mII} - g_{mI})] + G_I G_{II} + g_{mI} g_{mII}}{(sC_{gd7} + g_{ds7})(s(C_I + C_c) + G_I)}$$

### Negative $PSRR$ of the Two-Stage Op Amp with $V_{Bias}$ Connected to $V_{SS}$ - Continued

Assuming that  $g_{mII} > g_{mI}$  and solving for the approximate roots of both the numerator and denominator gives

$$PSRR^- = \frac{V_{ss}}{V_{out}} \approx \left( \frac{g_{mI} g_{mII}}{G_I g_{ds7}} \right) \left[ \frac{\left( \frac{sC_c}{g_{mI}} + 1 \right) \left( \frac{s(C_c C_I + C_I C_{II} + C_c C_{II})}{g_{mII} C_c} + 1 \right)}{\left( \frac{sC_{gd7}}{g_{ds7}} + 1 \right) \left( \frac{s(C_I + C_c)}{G_I} + 1 \right)} \right]$$

This equation can be rewritten as

$$PSRR^- = \frac{V_{ss}}{V_{out}} \approx \left( \frac{G_{II} A_{v0}}{g_{ds7}} \right) \left[ \frac{\left( \frac{s}{GB} + 1 \right) \left( \frac{s}{|p_2|} + 1 \right)}{\left( \frac{sC_{gd7}}{g_{ds7}} + 1 \right) \left( \frac{sC_c}{G_I} + 1 \right)} \right]$$

Comments:

- DC gain has been increased by the ratio of  $G_{II}$  to  $g_{ds7}$
- Two poles instead of one, however the pole at  $-g_{ds7}/C_{gd7}$  is large and can be ignored.

Using the values of Ex. 6.3-1 and assume that  $C_{ds7} = 10\text{fF}$ , gives,

$$PSRR^-(0) = 76.7\text{dB} \quad \text{and} \quad \text{Poles at } -71.2\text{kHz and } -149\text{MHz}$$

### Frequency Response of the Negative $PSRR$ of the Two-Stage Op Amp with $V_{Bias}$ Connected to $V_{SS}$

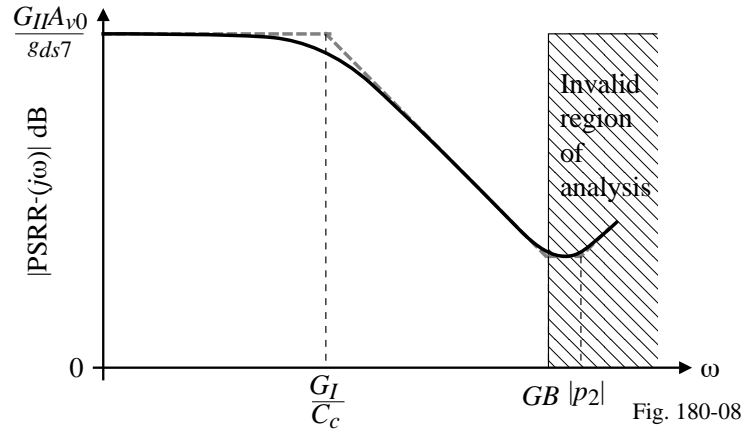

### Approximate Model for Negative $PSRR$ with $V_{Bias}$ Connected to Ground

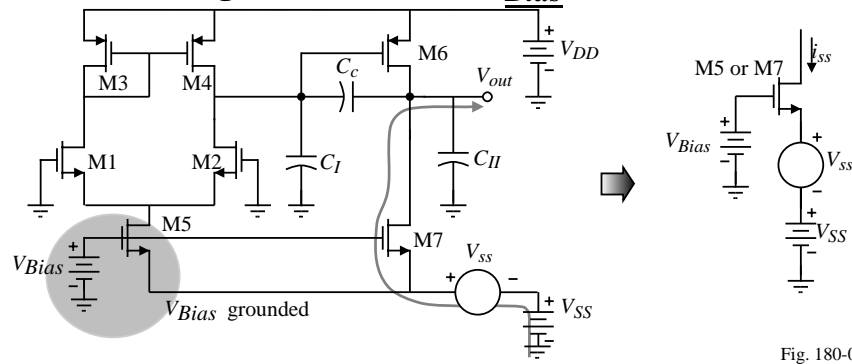

Path through the input stage is not important as long as the  $CMRR$  is high.

Path through the output stage:

$$v_{out} \approx i_{ss}Z_{out} = g_{m7}Z_{out}V_{ss}$$

$$\therefore \frac{V_{out}}{V_{ss}} = g_{m7}Z_{out} = g_{m7}R_{out} \left( \frac{1}{sR_{out}C_{out} + 1} \right)$$

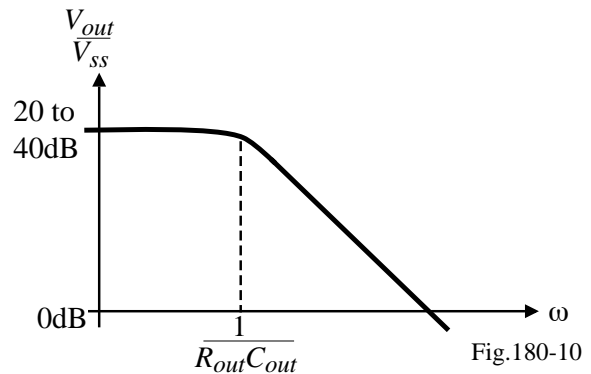

### Approximate Model for Negative *PSRR* with $V_{Bias}$ Connected to $V_{SS}$

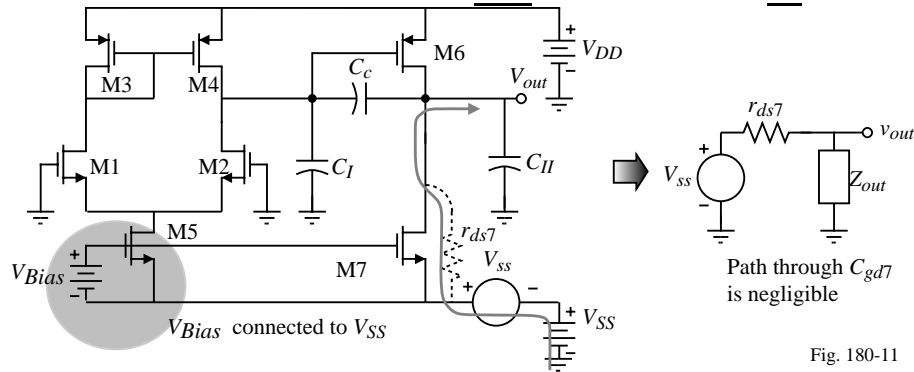

Fig. 180-11

What is  $Z_{out}$ ?

$$Z_{out} = \frac{V_t}{I_t} \Rightarrow$$

$$I_t = g_{mII}V_1 = g_{mII} \left( \frac{g_{mI}V_t}{G_I + sC_I + sC_C} \right)$$

$$\text{Thus, } Z_{out} = \frac{G_I + s(C_I + C_C)}{g_{mI}g_{mII}}$$

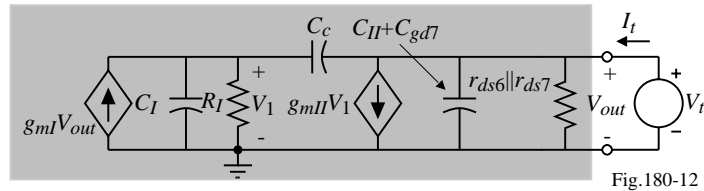

Fig.180-12

$$\therefore \frac{V_{out}}{V_{SS}} = \frac{1 + \frac{r_{ds7}}{Z_{out}}}{1} = \frac{s(C_C + C_I) + G_I + g_{mI}g_{mII}r_{ds7}}{s(C_C + C_I) + G_I} \Rightarrow \text{Pole at } \frac{-G_I}{C_C + C_I}$$

The two-stage op amp will never have good *PSRR* because of the Miller compensation.

## SECTION 6.5 - CASCODE OP AMPS

### Why Cascode Op Amps?

- Control of the frequency behavior
- Can get more gain by increasing the output resistance of a stage
- In the past section, *PSRR* of the two-stage op amp was insufficient for many applications
- A two-stage op amp can become unstable for large load capacitors (if nulling resistor is not used)
- We will see in future sections that the cascode op amp leads to wider *ICMR* and/or smaller power supply requirements

### Where Should the Cascode Technique be Used?

- First stage -
  - Good noise performance
  - Requires level translation to second stage
  - Degrades the Miller compensation
- Second stage -
  - Self compensating
  - Increases the efficiency of the Miller compensation
  - Increases *PSRR*

### Use of Cascoding in the First Stage of the Two-Stage Op Amp

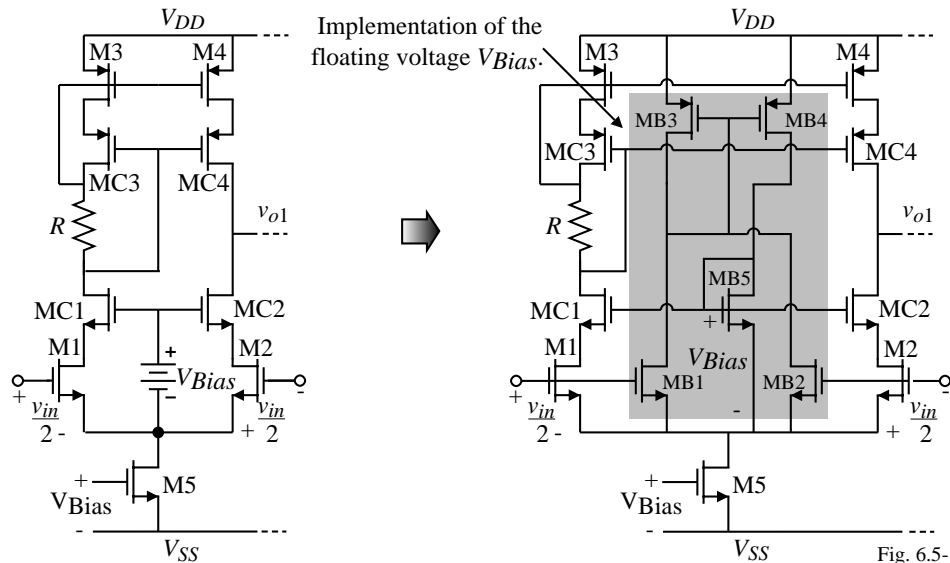

$R_{out}$  of the first stage is  $R_I \approx (g_{mC2}r_{dsC2}r_{ds2}) \parallel (g_{mC4}r_{dsC4}r_{ds4})$

Voltage gain =  $\frac{v_{o1}}{v_{in}} = g_{m1}R_I$  [The gain is increased by approximately  $0.5(g_{mC}r_{ds}C)$ ]

As a single stage op amp, the compensation capacitor becomes the load capacitor.

### Example 6.5-1 Single-Stage, Cascode Op Amp Performance

Assume that all  $W/L$  ratios are  $10 \mu\text{m}/1 \mu\text{m}$ , and that  $I_{DS1} = I_{DS2} = 50 \mu\text{A}$  of single stage op amp. Find the voltage gain of this op amp and the value of  $C_I$  if  $GB = 10 \text{ MHz}$ . Use the model parameters of Table 3.1-2.

#### Solution

The device transconductances are

$$g_{m1} = g_{m2} = g_{mI} = 331.7 \mu\text{S}$$

$$g_{mC2} = 331.7 \mu\text{S}$$

$$g_{mC4} = 223.6 \mu\text{S}.$$

The output resistance of the NMOS and PMOS devices is  $0.5 \text{ M}\Omega$  and  $0.4 \text{ M}\Omega$ , respectively.

$$\therefore R_I = 25 \text{ M}\Omega$$

$$A_v(0) = 8290 \text{ V/V}.$$

For a unity-gain bandwidth of  $10 \text{ MHz}$ , the value of  $C_I$  is  $5.28 \text{ pF}$ .

What happens if a  $100 \text{ pF}$  capacitor is attached to this op amp?

$GB$  goes from  $10 \text{ MHz}$  to  $0.53 \text{ MHz}$ .

### Two-Stage Op Amp with a Cascoded First-Stage

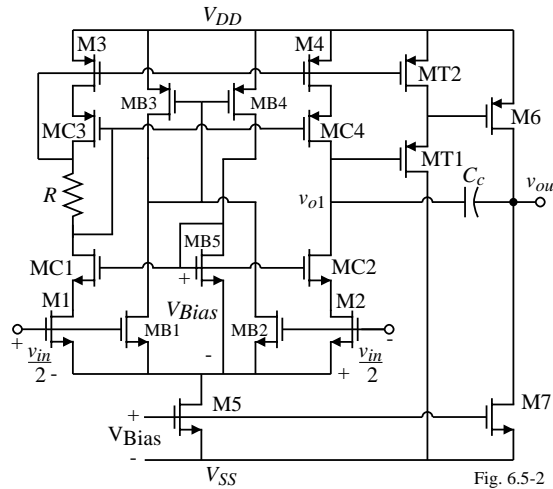

Fig. 6.5-2

- MT1 and MT2 are required for level shifting from the first-stage to the second.
- The PSRR+ is improved by the presence of MT1
- Internal loop pole at the gate of M6 may cause the Miller compensation to fail.
- The voltage gain of this op amp could easily be 100,000V/V

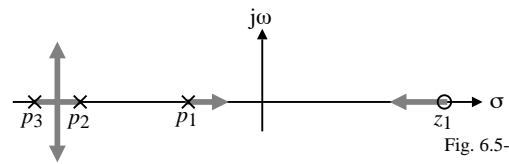

Fig. 6.5-2A

### Two-Stage Op Amp with a Cascode Second-Stage

$$A_v = g_{mI} g_{mII} R_I R_{II}$$

where  $g_{mI} = g_{m1} = g_{m2}$ ,  $g_{mII} = g_{m6}$ ,

$$R_I = \frac{1}{g_{ds2} + g_{ds4}} = \frac{2}{(\lambda_2 + \lambda_4) I_{D5}}$$

and

$$R_{II} = (g_{mC6} r_{dsC6} r_{ds6}) || (g_{mC7} r_{dsC7} r_{ds7})$$

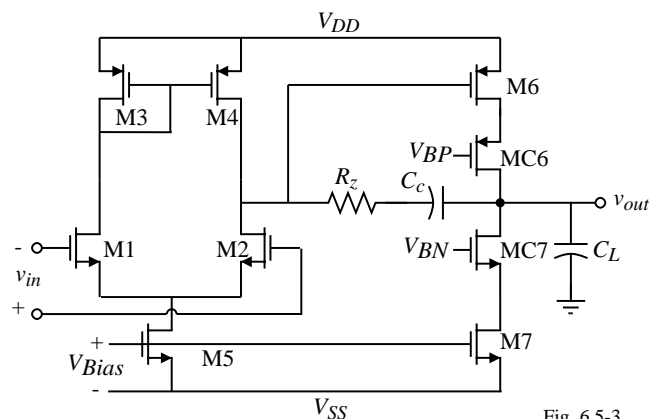

Fig. 6.5-3

Comments:

- The second-stage gain has greatly increased improving the Miller compensation
- The overall gain is approximately  $(g_m r_{ds})^3$  or very large
- Output pole,  $p_2$ , is approximately the same if  $C_c$  is constant
- The zero RHP is the same if  $C_c$  is constant
- PSRR is poor unless the Miller compensation is removed (then the op amp becomes self compensated)

### A Balanced, Two-Stage Op Amp using a Cascode Output Stage

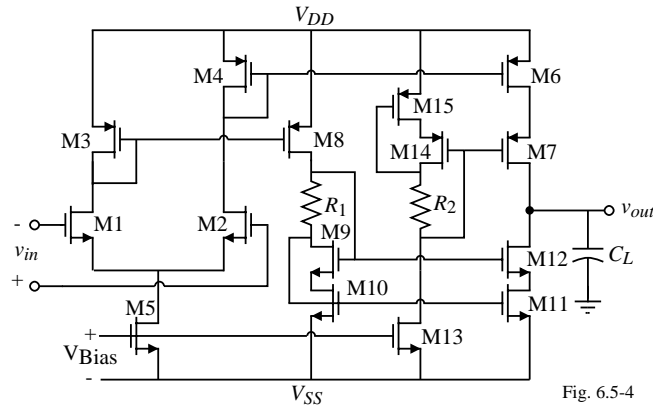

Fig. 6.5-4

$$v_{out} = \left( \frac{g_{m1}g_{m8}}{g_{m3}} \frac{v_{in}}{2} + \frac{g_{m2}g_{m6}}{g_{m4}} \frac{v_{in}}{2} \right) R_{II}$$

$$= \left( \frac{g_{m1}}{2} + \frac{g_{m2}}{2} \right) k v_{in} R_{II} = g_{m1} \cdot k \cdot R_{II} v_{in}$$

where

$$R_{II} = (g_{m7}r_{ds7}r_{ds6}) \parallel (g_{m12}r_{ds12}r_{ds11})$$

and

$$k = \frac{g_{m8}}{g_{m3}} = \frac{g_{m6}}{g_{m4}}$$

This op amp is balanced because the drain-to-ground loads for M1 and M2 are identical.

#### **TABLE 1 - Design Relationships for Balanced, Cascode Output Stage Op Amp.**

$$\text{Slew rate} = \frac{I_{out}}{C_L}$$

$$GB = \frac{g_{m1}g_{m8}}{g_{m3}C_L}$$

$$A_v = \frac{1}{2} \left( \frac{g_{m1}g_{m8}}{g_{m3}} + \frac{g_{m2}g_{m6}}{g_{m4}} \right) R_{II}$$

$$V_{in}(\text{max}) = V_{DD} - \left[ \frac{I_5}{\beta_3} \right]^{1/2} - |V_{TO3}|(\text{max}) + V_{T1}(\text{min})$$

$$V_{in}(\text{min}) = V_{SS} + V_{DS5} + \left[ \frac{I_5}{\beta_1} \right]^{1/2} + V_{T1}(\text{min})$$

### Example 6.5-2 Design of Balanced, Cascoded Output Stage Op Amp

The balanced, cascoded output stage op amp is a useful alternative to the two-stage op amp. Its design will be illustrated by this example. The pertinent design equations for the op amp were given above. The specifications of the design are as follows:

$$V_{DD} = -V_{SS} = 2.5 \text{ V}$$

$$\text{Slew rate} = 5 \text{ V}/\mu\text{s} \text{ with a } 50 \text{ pF load}$$

$$GB = 10 \text{ MHz with a } 25 \text{ pF load} \quad A_v \geq 5000$$

$$\text{Input CMR} = -1\text{V to } +1.5 \text{ V} \quad \text{Output swing} = \pm 1.5 \text{ V}$$

Use the parameters of Table 3.1-2 and let all device lengths be  $1 \mu\text{m}$ .

#### Solution

While numerous approaches can be taken, we shall follow one based on the above specifications. The steps will be numbered to help illustrate the procedure.

1.) The first step will be to find the maximum source/sink current. This is found from the slew rate.

$$I_{source}/I_{sink} = C_L \times \text{slew rate} = 50 \text{ pF}(5 \text{ V}/\mu\text{s}) = 250 \mu\text{A}$$

2.) Next some  $W/L$  constraints based on the maximum output source/sink current are developed. Under dynamic conditions, all of  $I_5$  will flow in M4; thus we can write

$$\text{Max. } I_{out}(\text{source}) = (S_6/S_4)I_5 \quad \text{and} \quad \text{Max. } I_{out}(\text{sink}) = (S_8/S_3)I_5$$

The maximum output sinking current is equal to the maximum output sourcing current if

$$S_3 = S_4, \quad S_6 = S_8, \quad \text{and} \quad S_{10} = S_{11}$$

**Example 6.5-2 - Continued**

3.) Choose  $I_5$  as  $100 \mu\text{A}$ . This current (which can be changed later) gives

$$S_6 = 2.5S_4 \text{ and } S_8 = 2.5S_3$$

Note that  $S_8$  could equal  $S_3$  if  $S_{11} = 2.5S_{10}$ . This would minimize the power dissipation.

4.) Next design for  $\pm 1.5 \text{ V}$  output capability. We shall assume that the output must source or sink the  $250 \mu\text{A}$  at the peak values of output. First consider the negative output peak. Since there is  $1 \text{ V}$  difference between  $V_{SS}$  and the minimum output, let  $V_{DS11}(\text{sat}) = V_{DS12}(\text{sat}) = 0.5 \text{ V}$  (we continue to ignore the bulk effects). Under the maximum negative peak assume that  $I_{11} = I_{12} = 250 \mu\text{A}$ . Therefore

$$0.5 = \sqrt{\frac{2I_{11}}{K'_N S_{11}}} = \sqrt{\frac{2I_{12}}{K'_N S_{12}}} = \sqrt{\frac{500 \mu\text{A}}{(110 \mu\text{A}/\text{V}^2)S_{11}}}$$

which gives  $S_{11} = S_{12} = 18.2$  and  $S_9 = S_{10} = 18.2$ . For the positive peak, we get

$$0.5 = \sqrt{\frac{2I_6}{K'_P S_6}} = \sqrt{\frac{2I_7}{K'_P S_7}} = \sqrt{\frac{500 \mu\text{A}}{(50 \mu\text{A}/\text{V}^2)S_6}}$$

which gives  $S_6 = S_7 = S_8 = 40$  and  $S_3 = S_4 = (40/2.5) = 16$ .

5.) Next the values of  $R_1$  and  $R_2$  are designed. For the resistor of the self-biased cascode we can write  $R_1 = V_{DS12}(\text{sat})/250 \mu\text{A} = 2\text{k}\Omega$  and  $R_2 = V_{SD7}(\text{sat})/250 \mu\text{A} = 2\text{k}\Omega$

**Example 6.5-2 - Continued**

Using this value of  $R_1$  ( $R_2$ ) will cause M11 to slightly be in the active region under quiescent conditions. One could redesign  $R_1$  to avoid this but the minimum output voltage under maximum sinking current would not be realized.

6.) Now we must consider the possibility of conflict among the specifications.

First consider the input CMR.  $S_3$  has already been designed as 16. Using ICMR relationship, we find that  $S_3$  should be at least 4.1. A larger value of  $S_3$  will give a higher value of  $V_{in}(\text{max})$  so that we continue to use  $S_3 = 16$  which gives  $V_{in}(\text{max}) = 1.95\text{V}$ .

Next, check to see if the larger W/L causes a pole below the gainbandwidth. Assuming a  $C_{ox}$  of  $0.4\text{fF}/\mu\text{m}^2$  gives the first-stage pole of

$$p_3 = \frac{-g_{m3}}{C_{gs3} + C_{gs8}} = \frac{-\sqrt{2K'_P S_3 I_3}}{(0.667)(W_3 L_3 + W_8 L_8) C_{ox}} = 33.15 \times 10^9 \text{ rads/sec or } 5.275\text{GHz}$$

which is much greater than  $10\text{GB}$ .

7.) Next we find  $g_{m1}$  ( $g_{m2}$ ). There are two ways of calculating  $g_{m1}$ .

(a.) The first is from the  $A_v$  specification. The gain is

$$A_v = (g_{m1}/2g_{m4})(g_{m6} + g_{m8}) R_{II}$$

Note, a current gain of  $k$  could be introduced by making  $S_6/S_4$  ( $S_8/S_3 = S_{11}/S_3$ ) equal to  $k$ .

$$\frac{g_{m6}}{g_{m4}} = \frac{g_{m11}}{g_{m3}} = \sqrt{\frac{2K'_P \cdot S_6 \cdot I_6}{2K'_P \cdot S_4 \cdot I_4}} = k$$

**Example 6.5-2 - Continued**

Calculating the various transconductances we get  $g_{m4} = 282.4 \mu\text{S}$ ,  $g_{m6} = g_{m7} = g_{m8} = 707 \mu\text{S}$ ,  $g_{m11} = g_{m12} = 707 \mu\text{S}$ ,  $r_{ds6} = r_{d7} = 0.16 \text{ M}\Omega$ , and  $r_{ds11} = r_{ds12} = 0.2 \text{ M}\Omega$ . Assuming that the gain  $A_v$  must be greater than 5000 and  $k = 2.5$  gives  $g_{m1} > 72.43 \mu\text{S}$ .

(b.) The second method of finding  $g_{m1}$  is from the  $GB$  specifications. Multiplying the gain by the dominant pole ( $1/C_{II}R_{II}$ ) gives

$$GB = \frac{g_{m1}(g_{m6} + g_{m8})}{2g_{m4}C_L}$$

Assuming that  $C_L = 25 \text{ pF}$  and using the specified  $GB$  gives  $g_{m1} = 251 \mu\text{S}$ .

Since this is greater than  $72.43 \mu\text{S}$ , we choose  $g_{m1} = g_{m2} = 251 \mu\text{S}$ . Knowing  $I_5$  gives  $S_1 = S_2 = 5.7 \approx 6$ .

8.) The next step is to check that  $S_1$  and  $S_2$  are large enough to meet the  $-1\text{V}$  input CMR specification. Use the saturation formula we find that  $V_{DS5}$  is  $0.261 \text{ V}$ . This gives  $S_5 = 26.7 \approx 27$ . The gain becomes  $A_v = 6,925\text{V/V}$  and  $GB = 10 \text{ MHz}$  for a  $25 \text{ pF}$  load. We shall assume that exceeding the specifications in this area is not detrimental to the performance of the op amp.

9.) With  $S_5 = 7$  then we can design  $S_{13}$  from the relationship

$$S_{13} = \frac{I_{13}}{I_5} S_5 = \frac{125 \mu\text{A}}{100 \mu\text{A}} 27 = 33.75 \approx 34$$

**Example 6.5-2 - Continued**

10.) Finally we need to design the value of  $V_{Bias}$ , which can be done with the values of  $S_5$  and  $I_5$  known. However, M5 is usually biased from a current source flowing into a MOS diode in parallel with the gate-source of M5. The value of the current source compared with  $I_5$  would define the  $W/L$  ratio of the MOS diode.

Table 2 summarizes the values of  $W/L$  that resulted from this design procedure. The power dissipation for this design is seen to be  $2 \text{ mW}$ . The next step would be begin simulation.

**Table 2 - Summary of  $W/L$  Ratios for Example 6.5-2**

$$S_1 = S_2 = 6$$

$$S_3 = S_4 = 16$$

$$S_5 = 27$$

$$S_6 = S_7 = S_8 = S_{14} = S_{15} = 40$$

$$S_9 = S_{10} = S_{11} = S_{12} = 18.2$$

$$S_{13} = 34$$

### Technological Implications of the Cascode Configuration

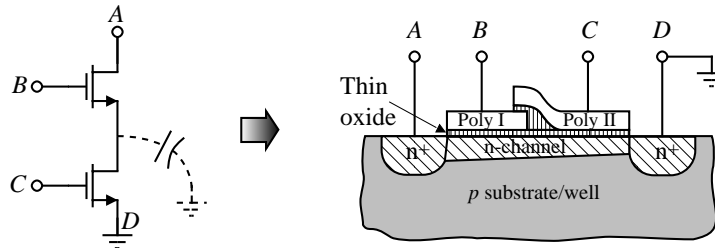

Fig. 6.5-5

If a double poly CMOS process is available, internode parasitics can be minimized. As an alternative, one should keep the drain/source between the transistors to a minimum area.

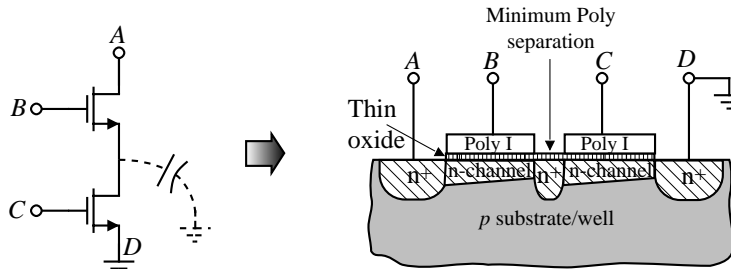
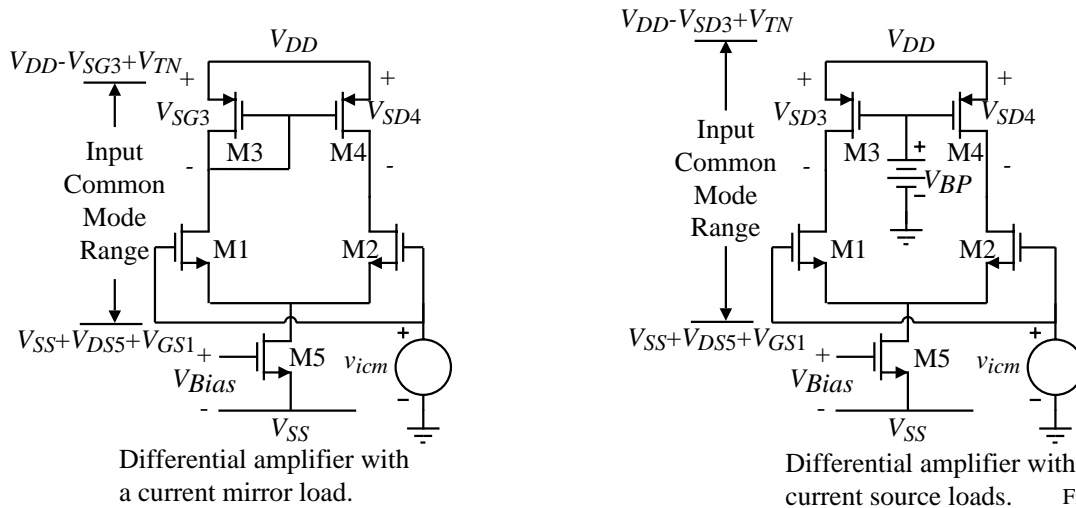

Fig. 6.5-5A

### Input Common Mode Range for Two Types of Differential Amplifier Loads



Differential amplifier with a current mirror load.

Differential amplifier with current source loads. Fig. 6.5-6

In order to improve the ICMR, it is desirable to use current source (sink) loads without losing half the gain.

The resulting solution is the *folded* cascode op amp.

## The Folded Cascode Op Amp

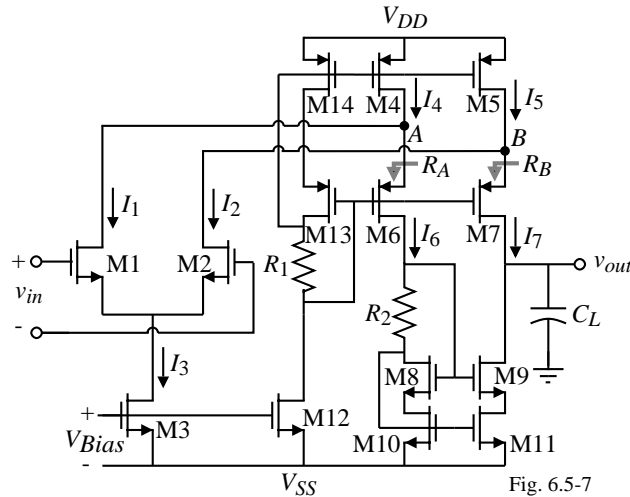

Fig. 6.5-7

Comments:

- $I_4$  and  $I_5$ , should be designed so that  $I_6$  and  $I_7$  never become zero (i.e.  $I_4=I_5=1.5I_3$ )
- This amplifier is nearly balanced (would be exactly if  $R_A$  was equal to  $R_B$ )
- Self compensating
- Poor noise performance, the gain occurs at the output so all intermediate transistors contribute to the noise along with the input transistors. (Some first stage gain can be achieved if  $R_A$  and  $R_B$  are greater than  $g_{m1}$  or  $g_{m2}$ .)

## Small-Signal Analysis of the Folded Cascode Op Amp

Model:

Recalling what we learned about the resistance looking into the source of the cascode transistor;

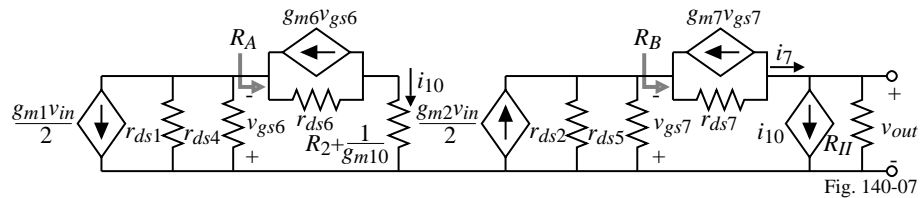

Fig. 140-07

$$R_A = \frac{r_{ds6} + R_2 + (1/g_{m10})}{1 + g_{m6}r_{ds6}} \approx \frac{1}{g_{m6}} \quad \text{and} \quad R_B = \frac{r_{ds7} + R_{II}}{1 + g_{m7}r_{ds7}} \approx \frac{R_{II}}{g_{m7}r_{ds7}} \quad \text{where} \quad R_{II} \approx g_{m9}r_{ds9}r_{ds11}$$

The small-signal voltage transfer function can be found as follows. The current  $i_{10}$  is written as

$$i_{10} = \frac{-g_{m1}(r_{ds1} || r_{ds4})v_{in}}{2[R_A + (r_{ds1} || r_{ds4})]} \approx \frac{-g_{m1}v_{in}}{2}$$

and the current  $i_7$  can be expressed as

$$i_7 = \frac{g_{m2}(r_{ds2} || r_{ds5})v_{in}}{2 \left[ \frac{R_{II}}{g_{m7}r_{ds7}} + (r_{ds2} || r_{ds5}) \right]} = \frac{g_{m2}v_{in}}{2 \left( 1 + \frac{R_{II}(g_{ds2} + g_{ds5})}{g_{m7}r_{ds7}} \right)} = \frac{g_{m2}v_{in}}{2(1+k)} \quad \text{where} \quad k = \frac{R_{II}(g_{ds2} + g_{ds5})}{g_{m7}r_{ds7}}$$

The output voltage,  $v_{out}$ , is equal to the sum of  $i_7$  and  $i_{10}$  flowing through  $R_{out}$ . Thus,

$$\frac{v_{out}}{v_{in}} = \left( \frac{g_{m1}}{2} + \frac{g_{m2}}{2(1+k)} \right) R_{out} = \left( \frac{2+k}{2+2k} \right) g_{m1} R_{out}$$

### Frequency Response of the Folded Cascode Op Amp

The frequency response of the folded cascode op amp is determined primarily by the output pole which is given as

$$p_{out} = \frac{-1}{R_{out}C_{out}}$$

where  $C_{out}$  is all the capacitance connected from the output of the op amp to ground. All other poles must be greater than  $GB = g_{m1}/C_{out}$ . The approximate expressions for each pole is

1.) Pole at node A:  $p_A \approx -g_{m6}/C_A$

2.) Pole at node B:  $p_B \approx -g_{m7}/C_B$

3.) Pole at drain of M6:  $p_6 \approx \frac{-1}{(R_2+1/g_{m10})C_6}$

4.) Pole at source of M8:  $p_8 \approx -g_{m8}/C_8$

5.) Pole at source of M9:  $p_9 \approx -g_{m9}/C_9$

6.) Pole at gate of M10:  $p_{10} \approx -g_{m10}/C_{10}$

where the approximate expressions are found by the reciprocal product of the resistance and parasitic capacitance seen to ground from a given node. One might feel that because  $R_B$  is approximately  $r_{ds}$  that this pole might be too small. However, at frequencies where this pole has influence,  $C_{out}$  causes  $R_{out}$  to be much smaller making  $p_B$  also non-dominant.

### Example 6.5-3 - Folded Cascode, CMOS Op Amp

Assume that all  $g_{mN} = g_{mP} = 100\mu S$ ,  $r_{dsN} = 2M\Omega$ ,  $r_{dsP} = 1M\Omega$ , and  $C_L = 10pF$ . Find all of the small-signal performance values for the folded-cascode op amp.

$$R_{II} = 0.4G\Omega, R_A = 10k\Omega, \text{ and } R_B = 4M\Omega \quad \therefore k = \frac{0.4 \times 10^9 (0.3 \times 10^{-6})}{100} = 1.2$$

$$\frac{v_{out}}{v_{in}} = \left( \frac{2+1.2}{2+2.4} \right) (100)(57.143) = 4,156V/V$$

$$R_{out} = R_{II} \parallel [g_{m7}r_{ds7}(r_{ds5} \parallel r_{ds2})] = 400M\Omega \parallel [(100)(0.667M\Omega)] = 57.143M\Omega$$

$$|p_{out}| = \frac{1}{R_{out}C_{out}} = \frac{1}{57.143M\Omega \cdot 10pF} = 1,750 \text{ rads/sec.} \Rightarrow 278\text{Hz} \Rightarrow GB = 1.21\text{MHz}$$

### PSRR of the Folded Cascode Op Amp

Consider the following circuit used to model the  $PSRR^-$ :

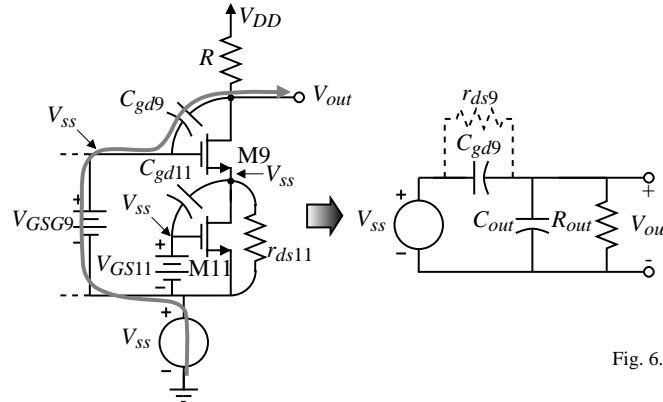

Fig. 6.5-9A

This model assumes that gate, source and drain of M11 and the gate and source of M9 all vary with  $V_{SS}$ .

We shall examine  $V_{out}/V_{SS}$  rather than  $PSRR^-$ . (Small  $V_{out}/V_{SS}$  will lead to large  $PSRR^-$ .)

The transfer function of  $V_{out}/V_{SS}$  can be found as

$$\frac{V_{out}}{V_{SS}} \approx \frac{sC_{gd9}R_{out}}{sC_{out}R_{out}+1} \quad \text{for } C_{gd9} < C_{out}$$

The approximate  $PSRR^-$  is sketched on the next page.

### Frequency Response of the $PSRR^-$ of the Folded Cascode Op Amp

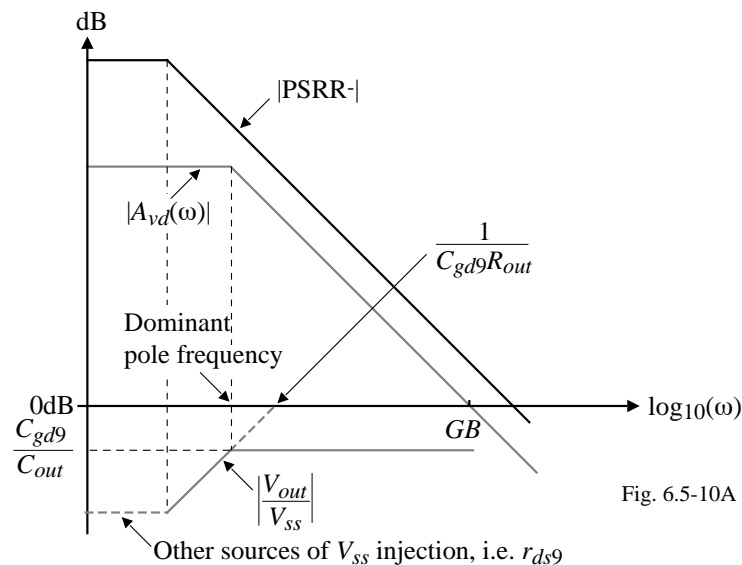

Fig. 6.5-10A

We see that the  $PSRR$  of the cascode op amp is much better than the two-stage op amp.

### Design Approach for the Folded-Cascode Op Amp

Step	Relationship	Design Equation/Constraint	Comments
1	Slew Rate	$I_3 = SR \cdot C_L$	
2	Bias currents in output cascodes	$I_4 = I_5 = 1.2I_3$ to $1.5I_3$	Avoid zero current in cascodes
3	Maximum output voltage, $v_{out(max)}$	$S_5 = \frac{2I_5}{K_P \cdot V_{SD5}^2}$ , $S_7 = \frac{2I_7}{K_P \cdot V_{SD7}^2}$ , $S_4 = S_{14} = S_5$ , $S_{13} = S_6 = S_7$	$V_{SD5(sat)} = V_{SD7(sat)} = 0.5[V_{DD} - V_{out(max)}]$
4	Minimum output voltage, $v_{out(min)}$	$S_{11} = \frac{2I_{11}}{K_N \cdot V_{DS11}^2}$ , $S_9 = \frac{2I_9}{K_N \cdot V_{DS9}^2}$ , ( $S_{10} = S_{11}$ & $S_8 = S_9$ )	$V_{DS9(sat)} = V_{DS11(sat)} = 0.5[V_{out(min)} - V_{SS}]$
5	Self-bias cascode	$R_1 = V_{SD14(sat)}/I_{14}$ and $R_2 = V_{DS8(sat)}/I_6$	
6	$GB = \frac{gm1}{C_L}$	$S_1 = S_2 = \frac{gm1^2}{K_N \cdot I_3} = \frac{GB^2 C_L^2}{K_N \cdot I_3}$	
7	Minimum input CM	$S_3 = \frac{2I_3}{K_N \cdot (V_{in(min)} - V_{SS} - \sqrt{(I_3/K_N \cdot S_1) \cdot V_{T1}})^2}$	
8	Maximum input CM	$S_4 = S_5 = \frac{2I_4}{K_P \cdot (V_{DD} - V_{in(max)} + V_{T1})^2}$	$S_4$ and $S_5$ must meet or exceed value in step 3
9	Differential Voltage Gain	$\frac{v_{out}}{v_{in}} = \left( \frac{gm1}{2} + \frac{gm2}{2(1+k)} \right) R_{out} = \left( \frac{2+k}{2+2k} \right) gm1 R_{out}$	$k = \frac{R_{II}(g_{ds2} + g_{ds4})}{gm7 r_{ds7}}$
10	Power dissipation	$P_{diss} = (V_{DD} - V_{SS})(I_3 + I_{12} + I_{10} + I_{11})$	

### Example 6.5-3 Design of a Folded-Cascode Op Amp

Follow the procedure given to design the folded-cascode op amp when the slew rate is  $10V/\mu s$ , the load capacitor is  $10pF$ , the maximum and minimum output voltages are  $\pm 2V$  for  $\pm 2.5V$  power supplies, the  $GB$  is  $10MHz$ , the minimum input common mode voltage is  $-1.5V$  and the maximum input common mode voltage is  $2.5V$ . The differential voltage gain should be greater than  $5,000V/V$  and the power dissipation should be less than  $5mW$ . Use channel lengths of  $1\mu m$ .

#### Solution

Following the approach outlined above we obtain the following results.

$$I_3 = SR \cdot C_L = 10 \times 10^6 \cdot 10^{-11} = 100 \mu A$$

Select  $I_4 = I_5 = 125 \mu A$ .

Next, we see that the value of  $0.5(V_{DD} - V_{out(max)})$  is  $0.5V/2$  or  $0.25V$ . Thus,

$$S_4 = S_5 = S_{14} = \frac{2 \cdot 125 \mu A}{50 \mu A/V^2 \cdot (0.25V)^2} = \frac{2 \cdot 125 \cdot 16}{50} = 80$$

and assuming worst case currents in  $M_6$  and  $M_7$  gives,

$$S_6 = S_7 = S_{13} = \frac{2 \cdot 125 \mu A}{50 \mu A/V^2 \cdot (0.25V)^2} = \frac{2 \cdot 125 \cdot 16}{50} = 80$$

The value of  $0.5(V_{out(min)} - |V_{SS}|)$  is also  $0.25V$  which gives the value of  $S_8$ ,  $S_9$ ,  $S_{10}$  and

$$S_{11} \text{ as } S_8 = S_9 = S_{10} = S_{11} = \frac{2 \cdot I_8}{K_N \cdot V_{DS8}^2} = \frac{2 \cdot 125}{110 \cdot (0.25)^2} = 36.36$$

**Example 6.5-3 - Continued**

The value of  $R_1$  and  $R_2$  is equal to  $0.25\text{V}/125\mu\text{A}$  or  $2\text{k}\Omega$ . In step 6, the value of  $GB$  gives  $S_1$  and  $S_2$  as

$$S_1 = S_2 = \frac{GB^2 \cdot C_L^2}{K_N' I_3} = \frac{(20\pi \times 10^6)^2 (10^{-11})^2}{110 \times 10^{-6} \cdot 100 \times 10^{-6}} = 35.9$$

The minimum input common mode voltage defines  $S_3$  as

$$S_3 = \frac{2I_3}{K_N' \left( V_{in(\min)} - V_{SS} - \sqrt{\frac{I_3}{K_N' S_1} - V_{T1}} \right)^2} = \frac{200 \times 10^{-6}}{110 \times 10^{-6} \left( -1.5 + 2.5 - \sqrt{\frac{100}{110 \cdot 35.9} - 0.7} \right)^2} = 91.6$$

We need to check that the values of  $S_4$  and  $S_5$  are large enough to satisfy the maximum input common mode voltage. The maximum input common mode voltage of 2.5 requires

$$S_4 = S_5 \geq \frac{2I_4}{K_P' [V_{DD} - V_{in(\max)} + V_{T1}]^2} = \frac{2 \cdot 125 \mu\text{A}}{50 \times 10^{-6} \mu\text{A}/\text{V}^2 [0.7\text{V}]^2} = 10.2$$

which is much less than 80. In fact, with  $S_4 = S_5 = 80$ , the maximum input common mode voltage is 3V. Finally,  $S_{12}$ , is given as

$$S_{12} = \frac{125}{100} S_3 = 114.53$$

The power dissipation is found to be  $P_{diss} = 5\text{V}(125\mu\text{A} + 125\mu\text{A} + 125\mu\text{A}) = 1.875\text{mW}$

**Example 6.5-3 - Continued**

The small-signal voltage gain requires the following values to evaluate:

$$S_4, S_5, S_{13}, S_{14}: \quad g_m = \sqrt{2 \cdot 125 \cdot 50 \cdot 80} = 1000 \mu\text{S} \quad \text{and} \quad g_{ds} = 125 \times 10^{-6} \cdot 0.05 = 6.25 \mu\text{S}$$

$$S_6, S_7: \quad g_m = \sqrt{2 \cdot 75 \cdot 50 \cdot 80} = 774.6 \mu\text{S} \quad \text{and} \quad g_{ds} = 75 \times 10^{-6} \cdot 0.05 = 3.75 \mu\text{S}$$

$$S_8, S_9, S_{10}, S_{11}: \quad g_m = \sqrt{2 \cdot 75 \cdot 110 \cdot 36.36} = 774.6 \mu\text{S} \quad \text{and} \quad g_{ds} = 75 \times 10^{-6} \cdot 0.04 = 3 \mu\text{S}$$

$$S_1, S_2: \quad g_{m1} = \sqrt{2 \cdot 50 \cdot 110 \cdot 35.9} = 628 \mu\text{S} \quad \text{and} \quad g_{ds} = 50 \times 10^{-6} (0.04) = 2 \mu\text{S}$$

Thus,

$$R_{II} \approx g_{m9} r_{ds9} r_{ds11} = (774.6 \mu\text{S}) \left( \frac{1}{3 \mu\text{S}} \right) \left( \frac{1}{3 \mu\text{S}} \right) = 86.07 \text{M}\Omega$$

$$R_{out} \approx 86.07 \text{M}\Omega \parallel (774.6 \mu\text{S}) \left( \frac{1}{3.75 \mu\text{S}} \right) \left( \frac{1}{2 \mu\text{S} + 6.25 \mu\text{S}} \right) = 19.40 \text{M}\Omega$$

$$k = \frac{R_{II}(g_{ds2} + g_{ds4})}{g_{m7} r_{ds7}} = \frac{86.07 \text{M}\Omega (2 \mu\text{S} + 6.25 \mu\text{S}) (3.75 \mu\text{S})}{774.6 \mu\text{S}} = 3.4375$$

The small-signal, differential-input, voltage gain is

$$A_{vd} = \left( \frac{2+k}{2+2k} \right) g_{m1} R_{out} = \left( \frac{2+3.4375}{2+6.875} \right) 0.628 \times 10^{-3} \cdot 19.40 \times 10^6 = 7,464 \text{ V/V}$$

The gain is larger than required by the specifications which should be okay.

### **Comments on Folded Cascode Op Amps**

- Good PSRR
- Good ICMR
- Self compensated
- Can cascade an output stage to get extremely high gain with lower output resistance (use Miller compensation in this case)
- Need first stage gain for good noise performance
- Widely used in telecommunication circuits where large dynamic range is required

## **SECTION 6.6 - SIMULATION AND MEASUREMENT OF OP AMPS**

### **Simulation and Measurement Considerations**

Objectives:

- The objective of simulation is to verify and optimize the design.
- The objective of measurement is to experimentally confirm the specifications.

Similarity Between Simulation and Measurement:

- Same goals
- Same approach or technique

Differences Between Simulation and Measurement:

- Simulation can idealize a circuit
- Measurement must consider all nonidealities

## Simulating or Measuring the Open-Loop Transfer Function of the Op Amp

Circuit (Darkened op amp identifies the op amp under test):

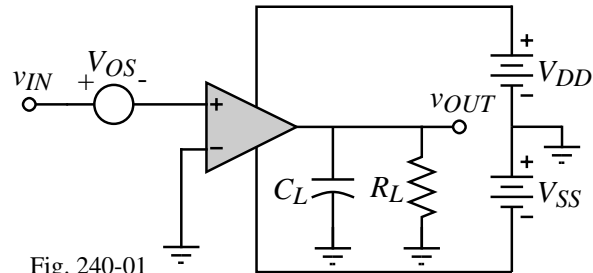

Fig. 240-01

Simulation:

This circuit will give the voltage transfer function curve. This curve should identify:

- 1.) The linear range of operation
- 2.) The gain in the linear range
- 3.) The output limits
- 4.) The systematic input offset voltage
- 5.) DC operating conditions, power dissipation
- 6.) When biased in the linear range, the small-signal frequency response can be obtained
- 7.) From the open-loop frequency response, the phase margin can be obtained ( $F = 1$ )

Measurement:

This circuit probably will not work unless the op amp gain is very low.

## A More Robust Method of Measuring the Open-Loop Frequency Response

Circuit:

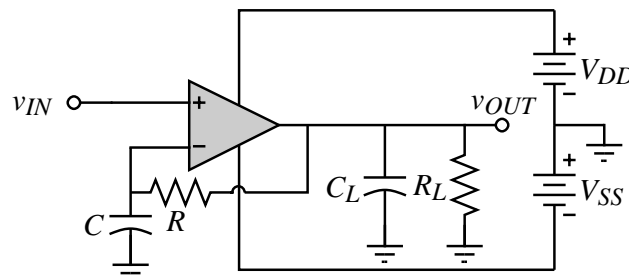

Fig. 240-02

Resulting Closed-Loop Frequency Response:

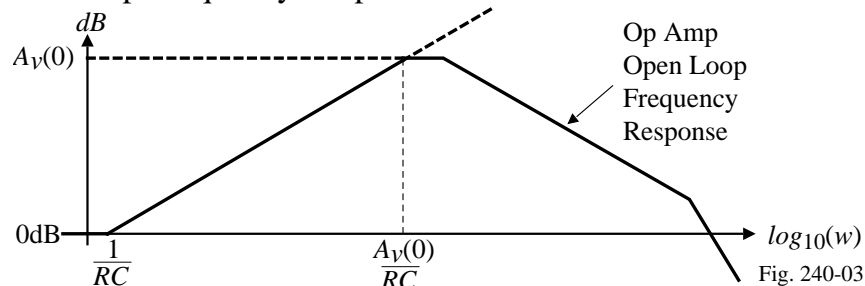

Fig. 240-03

Make the  $RC$  product as large as possible.

### Example 6.6-1 – Measurement of the Op Amp Open-Loop Gain

Develop the closed-loop frequency response for op amp circuit used to measure the open-loop frequency response. Sketch the closed-loop frequency response of the magnitude of  $V_{out}/V_{in}$  if the low frequency gain is 4000 V/V, the  $GB = 1\text{MHz}$ ,  $R = 10\text{M}\Omega$ , and  $C = 10\mu\text{F}$ .

#### Solution

The open-loop transfer function of the op amp is,

$$A_v(s) = \frac{GB}{s + (GB/A_v(0))} = \frac{2\pi \times 10^6}{s + 500\pi}$$

The closed-loop transfer function of the op amp can be expressed as,

$$\begin{aligned} v_{OUT} &= A_v(s) \left[ \left( \frac{-1/RC}{s + (1/RC)} \right) v_{OUT} + v_{IN} \right] \\ \therefore \frac{v_{OUT}}{v_{IN}} &= \frac{-[s + (1/RC)]A_v(s)}{s + (1/RC) + A_v(s)/RC} \\ &= \frac{-[s + (1/RC)]}{\frac{A_v(s)}{A_v(s)} + 1/RC} = \frac{-(s+0.01)}{\frac{A_v(s)}{A_v(s)} + 0.01} \end{aligned}$$

Substituting,  $A_v(s)$  gives,

$$\frac{v_{OUT}}{v_{IN}} = \frac{-2\pi \times 10^6 s - 2\pi \times 10^4}{(s+0.01)(s+500\pi) + 2\pi \times 10^4} = \frac{-2\pi \times 10^6 s - 2\pi \times 10^4}{s^2 + 500\pi s + 2\pi \times 10^4} = \frac{-2\pi \times 10^6 (s + 0.01)}{(s+41.07)(s+1529.72)}$$

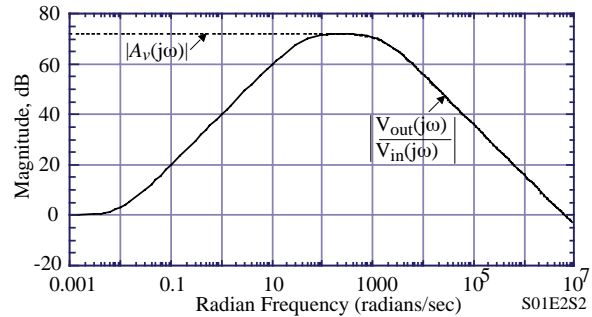

### Simulation and Measurement of Open-Loop Frequency Response with Moderate Gain Op Amps

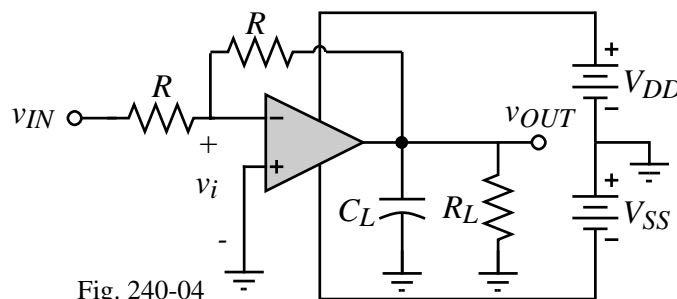

Fig. 240-04

Make  $R$  as large and measure  $v_{out}$  and  $v_i$  to get the open loop gain.

## Simulation or Measurement of the Input Offset Voltage of an Op Amp

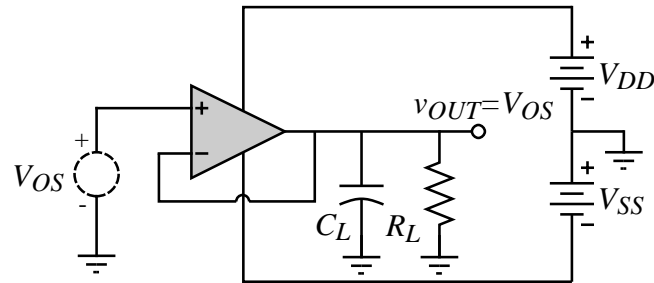

Fig. 6.6-4

Types of offset voltages:

- 1.) Systematic offset - due to mismatches in current mirrors, exists even with ideally matched transistors.
- 2.) Mismatch offset - due to mismatches in transistors (normally not available in simulation except through Monte Carlo methods).

## Simulation of the Common-Mode Voltage Gain

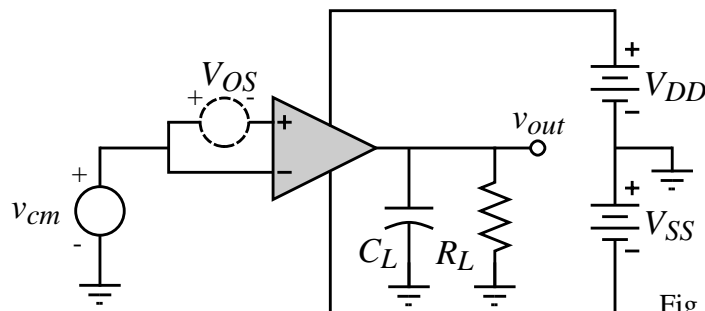

Fig. 6.6-5

Make sure that the output voltage of the op amp is in the linear region.

## Measurement of CMRR and PSRR

Configuration:

$$\text{Note that } v_I \approx \frac{v_{OS}}{1000} \quad \text{or} \quad v_{OS} \approx 1000v_I$$

How Does this Circuit Work?

CMRR:

1.) Set

$$V_{DD}' = V_{DD} + 1V$$

$$V_{SS}' = V_{SS} + 1V$$

$$v_{OUT}' = v_{OUT} + 1V$$

2.) Measure  $v_{OS}$  ( $v_{OS1}$ )

3.) Set

$$V_{DD}' = V_{DD} - 1V$$

$$V_{SS}' = V_{SS} - 1V$$

$$v_{OUT}' = v_{OUT} - 1V$$

4.) Measure  $v_{OS}$  ( $v_{OS2}$ )

5.)

$$CMRR = \frac{2000}{|v_{OS2} - v_{OS1}|}$$

PSRR:

1.) Set

$$V_{DD}' = V_{DD} + 1V$$

$$V_{SS}' = V_{SS}$$

$$v_{OUT}' = 0V$$

2.) Measure  $v_{OS}$  ( $v_{OS3}$ )

3.) Set

$$V_{DD}' = V_{DD} - 1V$$

$$V_{SS}' = V_{SS}$$

$$v_{OUT}' = 0V$$

4.) Measure  $v_{OS}$  ( $v_{OS4}$ )

5.)

$$PSRR^+ = \frac{2000}{|v_{OS4} - v_{OS3}|}$$

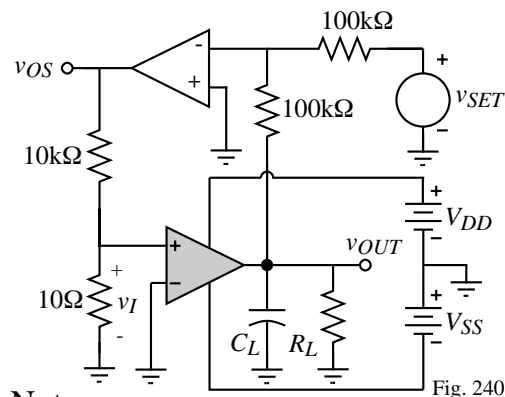

Note:

1.) PSRR<sup>-</sup> can be measured similar to PSRR<sup>+</sup> by changing only  $V_{SS}$ .

2.) The  $\pm 1V$  perturbation can be replaced by a sinusoid to measure CMRR or PSRR as follows:

$$PSRR^+ = \frac{1000 \cdot v_{dd}}{v_{os}}, \quad PSRR^- = \frac{1000 \cdot v_{ss}}{v_{os}}$$

$$\text{and } CMRR = \frac{1000 \cdot v_{cm}}{v_{os}}$$

## How Does the Previous Idea Work?

A circuit is shown which is used to measure the CMRR and PSRR of an op amp. Prove that the CMRR can be given as

$$CMRR = \frac{1000 v_{icm}}{v_{os}}$$

Solution

The definition of the common-mode rejection ratio is

$$CMRR = \left| \frac{A_{vd}}{A_{cm}} \right| = \frac{(v_{out}/v_{id})}{(v_{out}/v_{icm})}$$

However, in the above circuit the value of  $v_{out}$  is the same so that we get

$$CMRR = \frac{v_{icm}}{v_{id}}$$

But  $v_{id} = v_i$  and  $v_{os} \approx 1000v_i = 1000v_{id} \Rightarrow v_{id} = \frac{v_{os}}{1000}$

Substituting in the previous expression gives,  $CMRR = \frac{v_{icm}}{\frac{v_{os}}{1000}} = \frac{1000 v_{icm}}{v_{os}}$

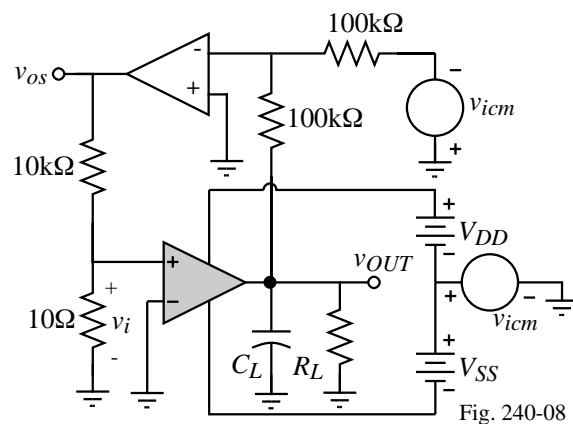

### Simulation of CMRR of an Op Amp

None of the above methods are really suitable for simulation of *CMRR*. Consider the following:

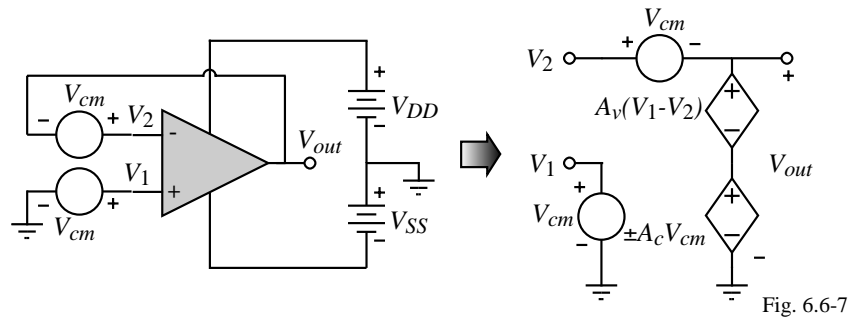

$$V_{out} = A_v(V_1 - V_2) \pm A_{cm} \left( \frac{V_1 + V_2}{2} \right) = -A_v V_{out} \pm A_{cm} V_{cm}$$

$$V_{out} = \frac{\pm A_{cm}}{1 + A_v} V_{cm} \approx \frac{\pm A_{cm}}{A_v} V_{cm}$$

$$\therefore \boxed{|CMRR| = \frac{A_v}{A_{cm}} = \frac{V_{cm}}{V_{out}}}$$

(However,  $PSRR^+$  must equal  $PSRR^-$ )

### CMRR of Ex. 6.3-1 using the Above Method of Simulation

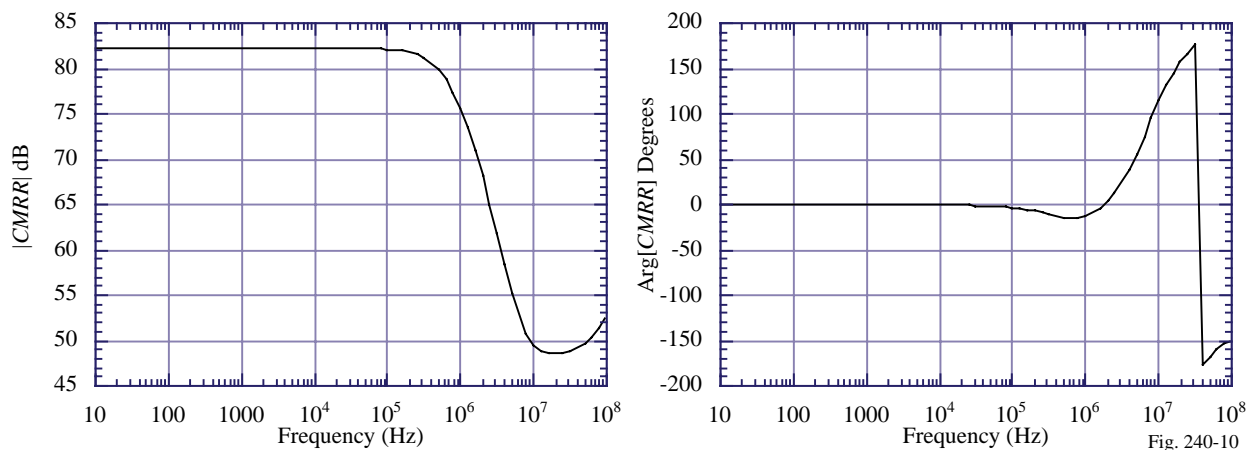

## Direct Simulation of PSRR

Circuit:

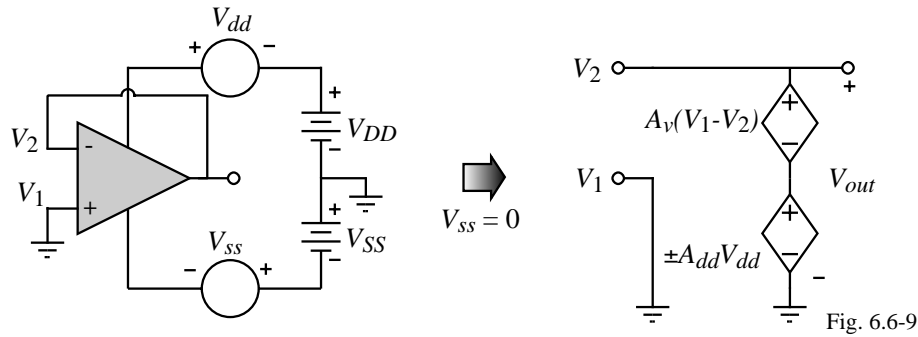

$$V_{out} = A_v(V_1 - V_2) \pm A_{dd}V_{dd} = -A_vV_{out} \pm A_{dd}V_{dd}$$

$$V_{out} = \frac{\pm A_{dd}}{1 + A_v} V_{dd} \approx \frac{\pm A_{dd}}{A_v} V_{dd}$$

$$\therefore \boxed{PSRR^+ = \frac{A_v}{A_{dd}} = \frac{V_{dd}}{V_{out}}} \quad \text{and} \quad \boxed{PSRR^- = \frac{A_v}{A_{ss}} = \frac{V_{ss}}{V_{out}}}$$

Works well as long as  $CMRR$  is much greater than 1.

## Simulation or Measurement of ICMR

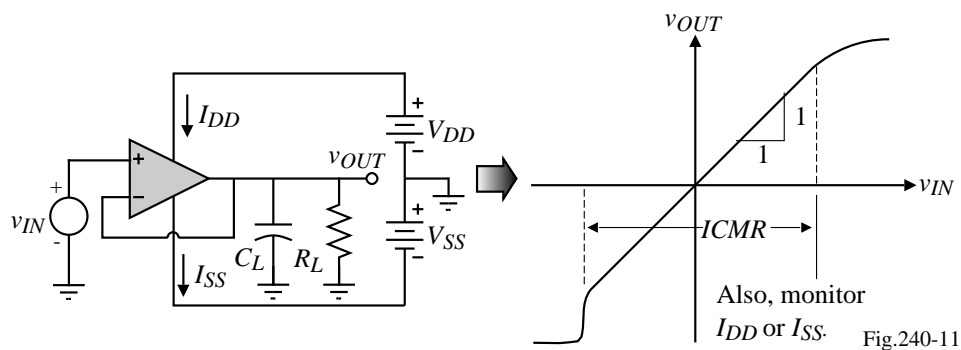

Initial jump in sweep is due to the turn-on of M5.

Should also plot the current in the input stage (or the power supply current).

## Measurement or Simulation of the Open-Loop Output Resistance

Method 1:

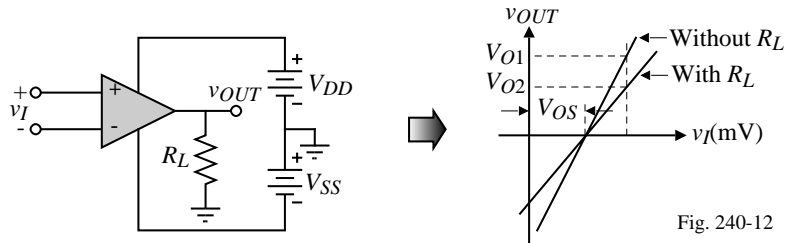

$$R_{out} = R_L \left( \frac{V_{O1}}{V_{O2}} - 1 \right) \quad \text{or vary } R_L \text{ until } V_{O2} = 0.5V_{O1} \Rightarrow R_{out} = R_L$$

Method 2:

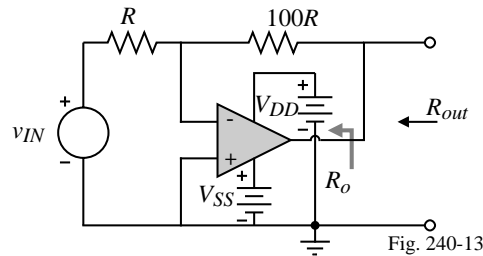

$$R_{out} = \left( \frac{1}{R_o} + \frac{1}{100R} + \frac{A_v}{100R_o} \right)^{-1} \approx \frac{100R_o}{A_v}$$

## Measurement or Simulation of Slew Rate and Settling Time

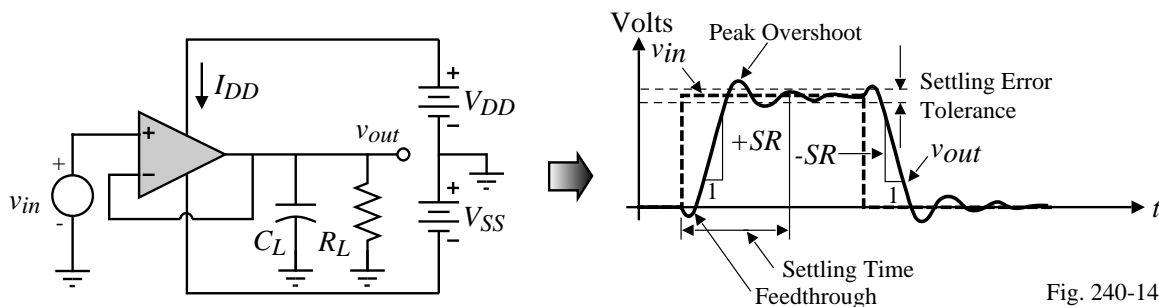

If the slew rate influences the small signal response, then make the input step size small enough to avoid slew rate (i.e. less than 0.5V for MOS).

### Phase Margin and Peak Overshoot Relationship

It can be shown (Appendix C of the text) that:

$$\text{Phase Margin (Degrees)} = 57.2958 \cos^{-1}[\sqrt{4\zeta^4 + 1} - 2\zeta^2]$$

Overshoot (%)

$$= 100 \exp\left(\frac{-\pi\zeta}{\sqrt{1-\zeta^2}}\right)$$

For example, a 5% overshoot corresponds to a phase margin of approximately  $64^\circ$ .

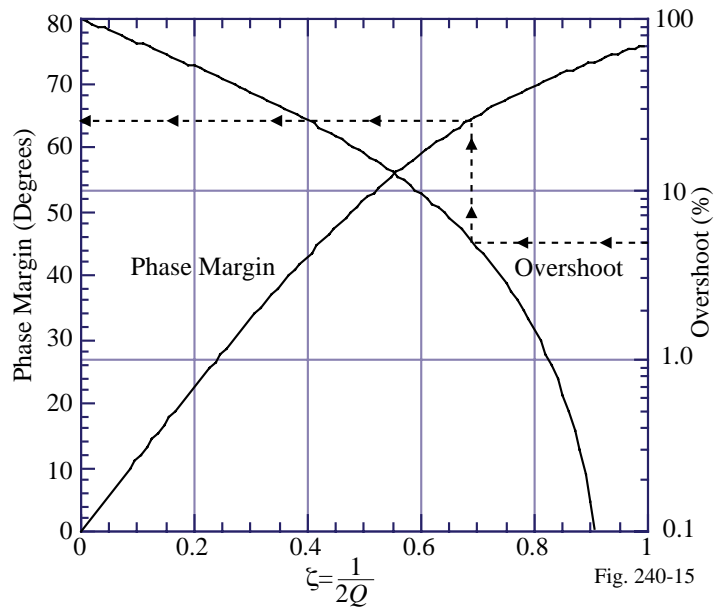

### Example 6.6-2 Simulation of the CMOS Op Amp of Ex. 6.3-1.

The op amp designed in Example 6.3-1 and shown in Fig. 6.3-3 is to be analyzed by SPICE to determine if the specifications are met. The device parameters to be used are those of Tables 3.1-2 and 3.2-1. In addition to verifying the specifications of Example 6.3-1, we will simulate PSRR+ and PSRR-.

#### Solution/Simulation

The op amp will be treated as a subcircuit in order to simplify the repeated analyses. The table on the next page gives the SPICE subcircuit description of Fig. 6.3-3. While the values of  $AD$ ,  $AS$ ,  $PD$ , and  $PS$  could be calculated if the physical layout was complete, we will make an educated estimate of these values by using the following approximations.

$$AS = AD \cong W[L1 + L2 + L3]$$

$$PS = PD \cong 2W + 2[L1 + L2 + L3]$$

where  $L1$  is the minimum allowable distance between the polysilicon and a contact in the moat (Rule 5C of Table 2.6-1),  $L2$  is the length of a minimum-size square contact to moat (Rule 5A of Table 2.6-1), and  $L3$  is the minimum allowable distance between a contact to moat and the edge of the moat (Rule 5D of Table 2.6-1).

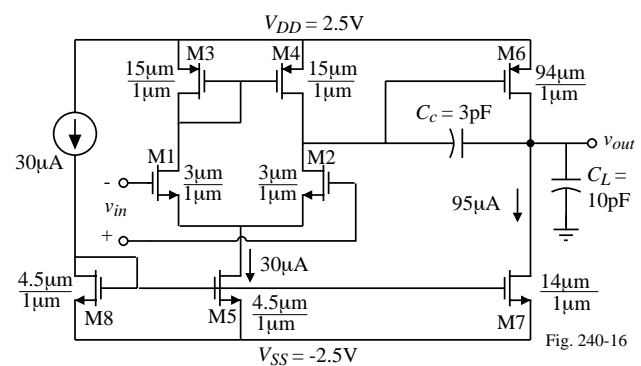

**Example 6.6-2 - Continued**

Op Amp Subcircuit:

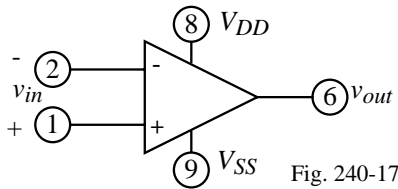

Fig. 240-17

```

.SUBCKT OPAMP 1 2 6 8 9
M1 4 2 3 3 NMOS1 W=3U L=1U AD=18P AS=18P PD=18U PS=18U
M2 5 1 3 3 NMOS1 W=3U L=1U AD=18P AS=18P PD=18U PS=18U
M3 4 4 8 8 PMOS1 W=15U L=1U AD=90P AS=90P PD=42U PS=42U
M4 5 4 8 8 PMOS1 W=15U L=1U AD=90P AS=90P PD=42U PS=42U
M5 3 7 9 9 NMOS1 W=4.5U L=1U AD=27P AS=27P PD=21U PS=21U
M6 6 5 8 8 PMOS1 W=94U L=1U AD=564P AS=564P PD=200U PS=200U
M7 6 7 9 9 NMOS1 W=14U L=1U AD=84P AS=84P PD=40U PS=40U
M8 7 7 9 9 NMOS1 W=4.5U L=1U AD=27P AS=27P PD=21U PS=21U
CC 5 6 3.0P
.MODEL NMOS1 NMOS VTO=0.70 KP=110U GAMMA=0.4 LAMBDA=0.04 PHI=0.7
+MJ=0.5 MJSW=0.38 CGBO=700P CGSO=220P CGDO=220P CJ=770U CJSW=380P
+LD=0.016U TOX=14N
.MODEL PMOS1 PMOS VTO=-0.7 KP=50U GAMMA=0.57 LAMBDA=0.05 PHI=0.8
+MJ=0.5 MJSW=.35 CGBO=700P CGSO=220P CGDO=220P CJ=560U CJSW=350P +LD=0.014U TOX=14N
IBIAS 8 7 30U
.ENDS

```

**Example 6.6-2 - Continued**

PSPICE Input File for the Open-Loop Configuration:

```

EXAMPLE 1 OPEN LOOP CONFIGURATION
.OPTION LIMPTS=1000
VIN+ 1 0 DC 0 AC 1.0
VDD 4 0 DC 2.5
VSS 0 5 DC 2.5
VIN - 2 0 DC 0
CL 3 0 10P
X1 1 2 3 4 5 OPAMP
:
:
(Subcircuit of previous slide)
:
:
.OP
.TF V(3) VIN+
.DC VIN+ -0.005 0.005 100U
.PRINT DC V(3)
.AC DEC 10 1 10MEG
.PRINT AC VDB(3) VP(3)
.PROBE (This entry is unique to PSPICE)
.END

```

**Example 6.6-2 - Continued**

Open-loop transfer characteristic of Example 6.3-1:

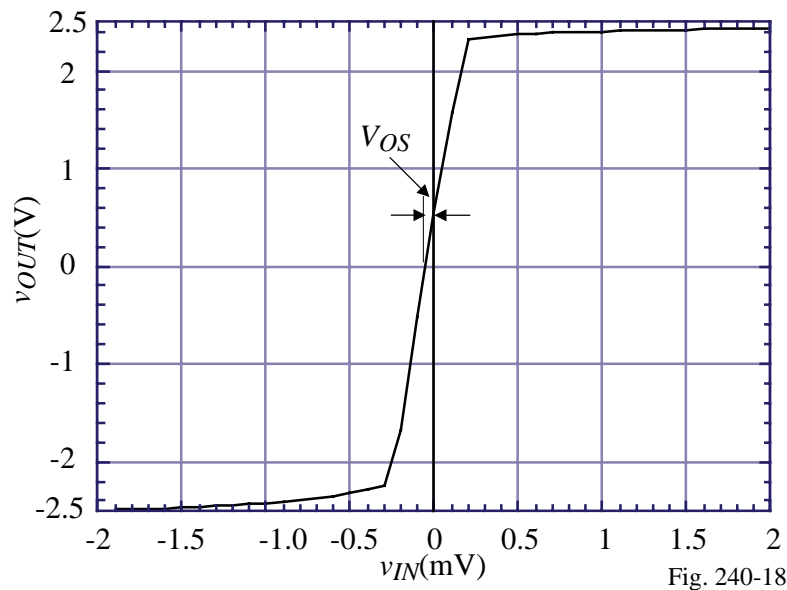

Fig. 240-18

**Example 6.6-2 - Continued**

Open-loop transfer frequency response of Example 6.3-1:

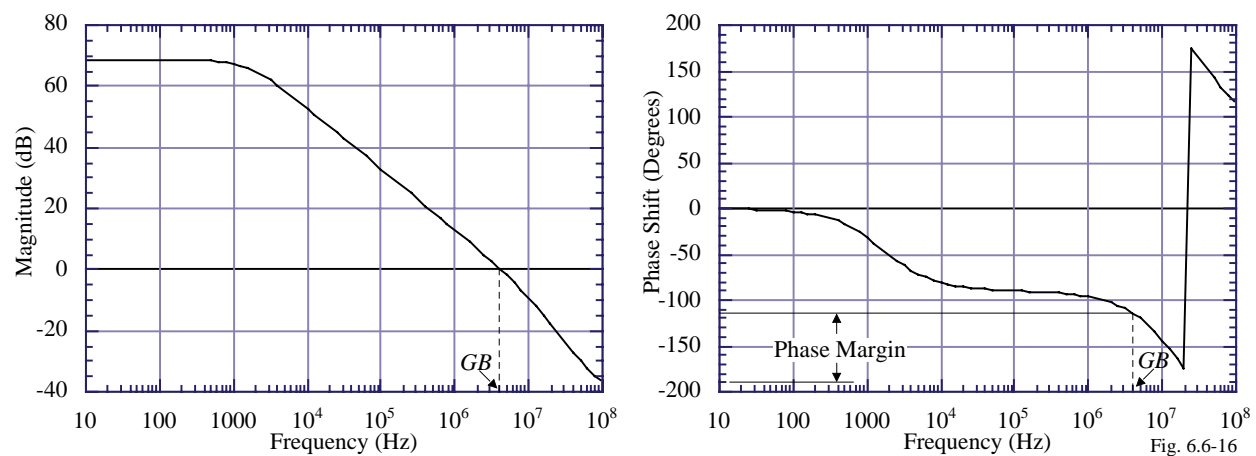

Fig. 6.6-16

**Example 6.6-2 - Continued**

Input common mode range of Example 6.3-1:

EXAMPLE 6.6-1 UNITY GAIN CONFIGURATION.

.OPTION LIMPTS=501

VIN+ 1 0 PWL(0 -2 10N -2 20N 2 2U 2 2.01U -2 4U -2 4.01U  
+ -.1 6U -.1 6.0 1U .1 8U .1 8.01U -.1 10U -.1)

VDD 4 0 DC 2.5 AC 1.0

VSS 0 5 DC 2.5

CL 3 0 20P

X1 1 3 3 4 5 OPAMP

⋮

(Subcircuit of Table 6.6-1)

⋮

.DC VIN+ -2.5 2.5 0.1

.PRINT DC V(3)

.TRAN 0.05U 10U 0 10N

.PRINT TRAN V(3) V(1)

.AC DEC 10 1 10MEG

.PRINT AC VDB(3) VP(3)

.PROBE (This entry is unique to PSPICE)

.END

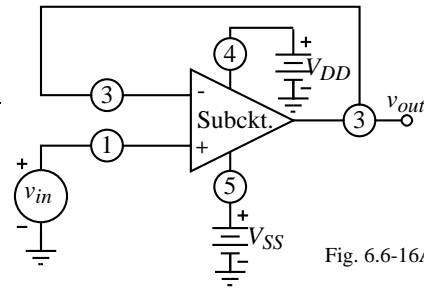

Fig. 6.6-16A

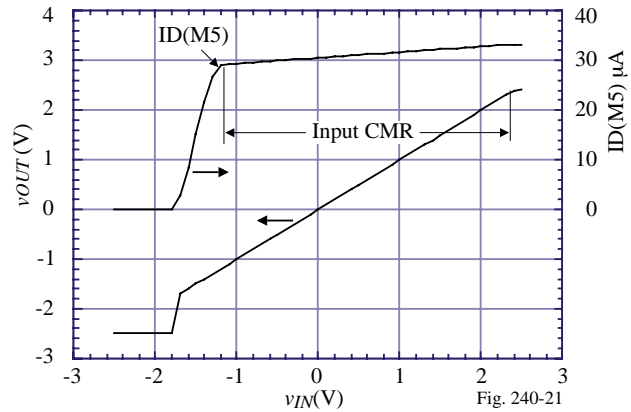

Fig. 240-21

**Example 6.6-2 - Continued**Positive *PSRR* of Example 6.3-1:

Fig. 240-22

**Example 6.6-2 - Continued**

Negative *PSRR* of Example 6.3-1:

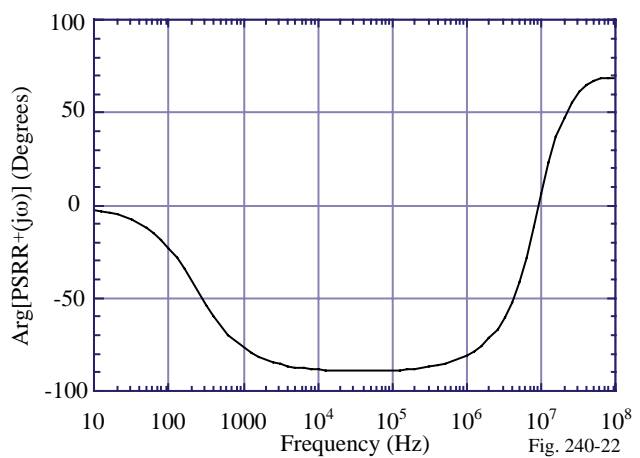
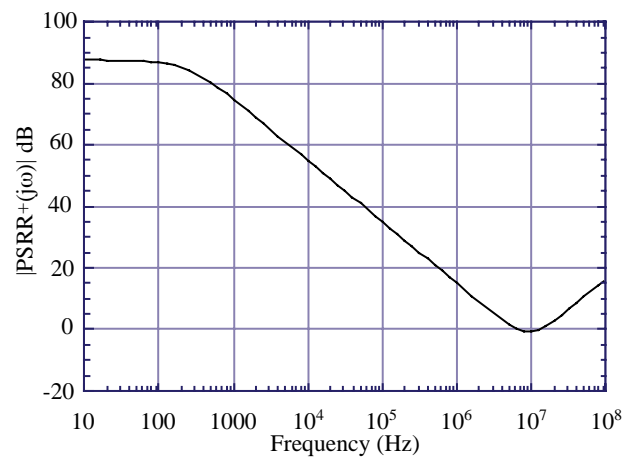
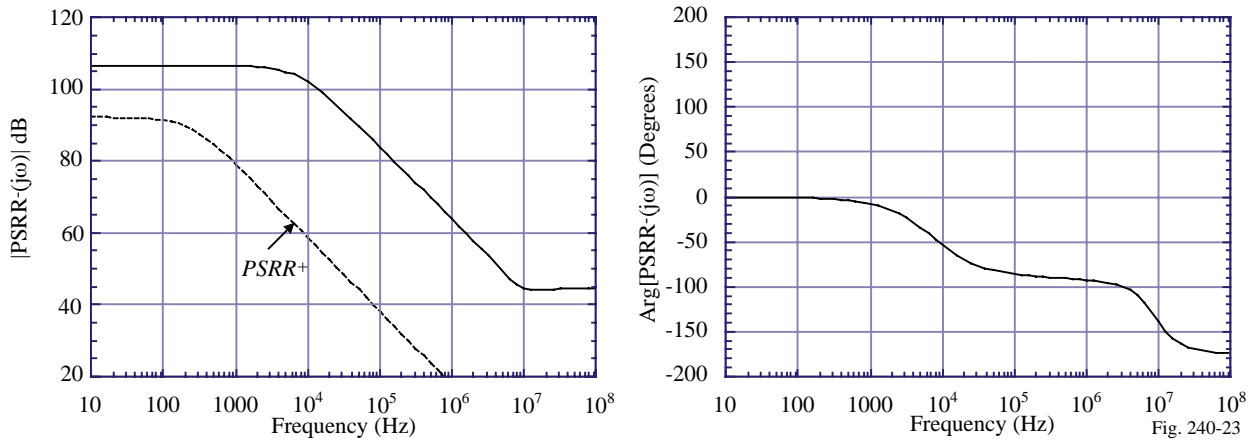

**Example 6.6-2 - Continued**

Large-signal and small-signal transient response of Example 6.3-1:

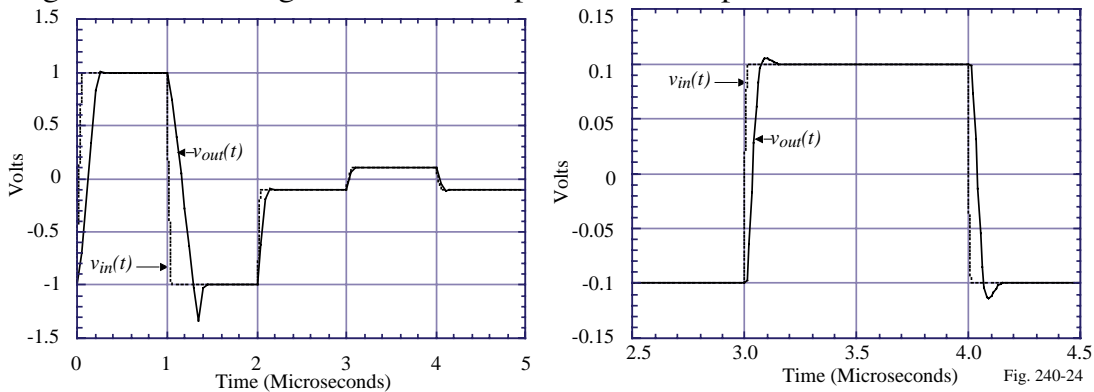

Why the negative overshoot on the slew rate?

If M7 cannot sink sufficient current then the output stage slews and only responds to changes at the output via the feedback path which involves a delay.

Note that  $-dv_{out}/dt \approx -2V/0.3\mu s = -6.67V/\mu s$ . For a 10pF capacitor this requires  $66.7\mu A$  and only  $95\mu A - 66.7\mu A = 28\mu A$  is available for  $C_c$ . For the positive slew rate, M6 can provide whatever current is required by the capacitors and can immediately respond to changes at the output.

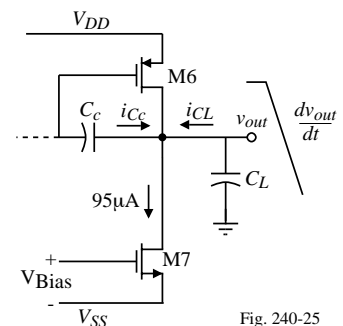

**Example 6.6-2 - Continued**

Comparison of the Simulation Results with the Specifications of Example 6.3-1:

Specification (Power supply = $\pm 2.5V$ )	Design (Ex. 6.3-1)	Simulation (Ex. 1)
Open Loop Gain	$>5000$	10,000
GB (MHz)	5 MHz	5 MHz
Input CMR (Volts)	-1V to 2V	-1.2 V to 2.4 V,
Slew Rate ( $V/\mu\text{sec}$ )	$>10$ ( $V/\mu\text{sec}$ )	+10, -7( $V/\mu\text{sec}$ )
$P_{\text{diss}}$ (mW)	$< 2\text{mW}$	0.625mW
$V_{\text{out}}$ range (V)	$\pm 2V$	+2.3V, -2.2V
PSRR+ (0) (dB)	-	87
PSRR- (0) (dB)	-	106
Phase margin (degrees)	$60^\circ$	$65^\circ$
Output Resistance ( $k\Omega$ )	-	122.5 $k\Omega$

**Example 6.6-3**

Why is the negative-going overshoot larger than the positive-going overshoot on the small-signal transient response of the last slide?

Consider the following circuit and waveform:

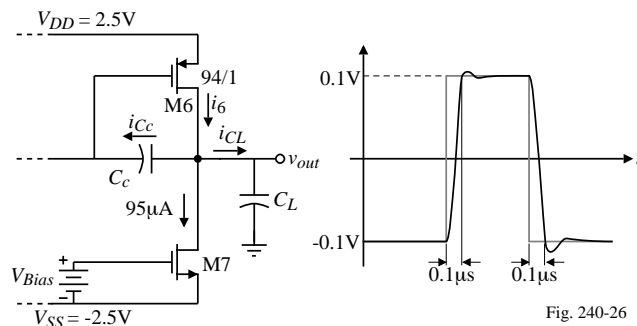

Fig. 240-26

During the rise time,

$$i_{CL} = C_L(dv_{out}/dt) = 10\text{pF}(0.2V/0.1\mu\text{s}) = 20\mu\text{A} \text{ and } i_{C_C} = 3\text{pf}(2V/\mu\text{s}) = 6\mu\text{A}$$

$$\therefore i_6 = 95\mu\text{A} + 20\mu\text{A} + 6\mu\text{A} = 121\mu\text{A} \Rightarrow g_{m6} = 1066\mu\text{S} \text{ (nominal was } 942.5\mu\text{S)}$$

$$\text{During the fall time, } i_{CL} = C_L(-dv_{out}/dt) = 10\text{pF}(-0.2V/0.1\mu\text{s}) = -20\mu\text{A}$$

$$\text{and } i_{C_C} = -3\text{pf}(2V/\mu\text{s}) = -6\mu\text{A}$$

$$\therefore i_6 = 95\mu\text{A} - 20\mu\text{A} - 6\mu\text{A} = 69\mu\text{A} \Rightarrow g_{m6} = 805\mu\text{S}$$

The dominant pole is  $p_1 \approx (R_I g_{m6} R_{II} C_C)^{-1}$  but the GB is  $g_{mI}/C_C = 94.25\mu\text{S}/3\text{pF} = 31.42 \times 10^6$  rads/sec and stays constant. Thus we must look elsewhere for the reason.

Recall that  $p_2 \approx g_{m6}/C_L$  which explains the difference.

$$\therefore p_2(95\mu\text{A}) = 94.25 \times 10^6 \text{ rads/sec, } p_2(121\mu\text{A}) = 106.6 \times 10^6 \text{ rads/sec, and } p_2(69\mu\text{A}) = 80.05 \times 10^6 \text{ rads/sec. Thus, the phase margin is less during the fall time than the rise time.}$$



### Example 6.7-1 - Use of the Simple Op Amp Model

Use SPICE to find the voltage gain,  $v_{out}/v_{in}$ , the input resistance,  $R_{in}$ , and the output resistance,  $R_{out}$  of Fig. 2. The op amp parameters are  $A_{vd} = 100,000$ ,  $R_{id} = 1\text{M}\Omega$ , and  $R_o = 100\Omega$ . Find the input resistance,  $R_{in}$ , the output resistance,  $R_{out}$ , and the voltage gain,  $A_v$ , of the noninverting voltage amplifier configuration when  $R_1 = 1\text{k}\Omega$  and  $R_2 = 100\text{k}\Omega$ .

#### Solution

The circuit with the SPICE node numbers identified is shown in Fig. 2.

Figure 2 – Noninverting voltage amplifier for Ex. 1.

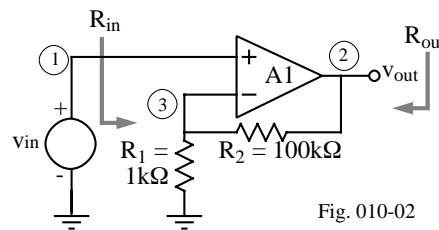

Fig. 010-02

The input file for this example is given as follows.

```
Example 1
VIN 1 0 DC 0 AC 1
XOPAMP1 1 3 2 SIMPLIOPAMP
R1 3 0 1KOHM
R2 2 3 100KOHM
.SUBCKT SIMPLIOPAMP 1 2 3
RID 1 2 1MEGOHM
RO 3 0 100OHM
GAVD/RO 0 3 1 2 1000
.ENDS SIMPLIOPAMP
.TF V(2) VIN
.END
```

The command .TF finds the small signal input resistance, output resistance, and voltage or current gain of an amplifier. The results extracted from the output file are:

```
**** SMALL-SIGNAL CHARACTERISTICS
V(2)/VIN = 1.009E+02
INPUT RESISTANCE AT VIN = 9.901E+08
OUTPUT RESISTANCE AT V(2) = 1.010E-01.
```

### Common Mode Model

Electrical Model:

$$v_o = A_{vd}(v_1 - v_2) + \frac{A_{cm}(v_1 + v_2)}{2}$$

Macromodel:

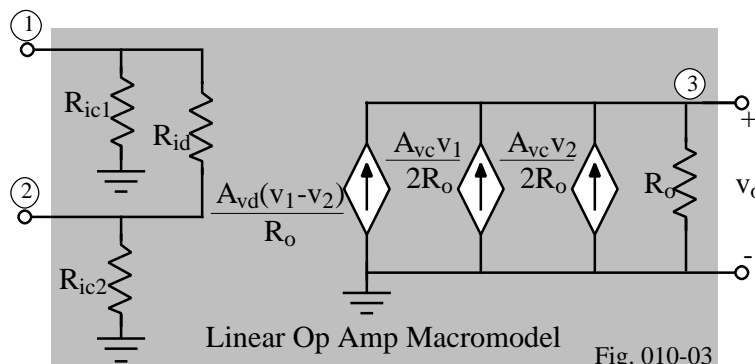

Fig. 010-03

Figure 3 - Simple op amp model including differential and common mode behavior.

SPICE File:

```
.SUBCKT LINOPAMP 1 2 3
RIC1 1 0 {Ric}
RID 1 2 {Rid}
RIC2 2 0 {Ric}
```

```
GAVD/RO 0 3 1 2 {A_vd/Ro}
GAVC1/RO 0 3 1 0 {A_vc/2Ro}
GAVC2/RO 0 3 2 0 {A_vc/2Ro}
RO 3 0 {Ro}
.ENDS LINOPAMP
```

## Small Signal, Frequency Dependent Op Amp Models

Dominant Pole Model:

$$A_{vd}(s) = \frac{A_{vd}(0)}{(s/\omega_1) + 1} \quad \text{where } \omega_1 = \frac{1}{R_1 C_1} \text{ (dominant pole)}$$

Model Using Passive Components:

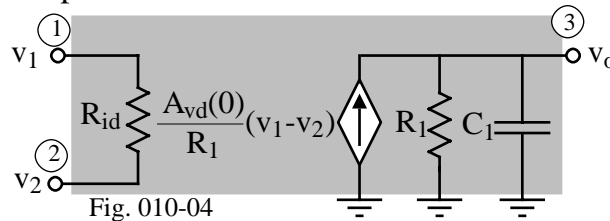

Figure 4 - Macromodel for the op amp including the frequency response of  $A_{vd}$ .  
Model Using Passive Components with Constant Output Resistance:

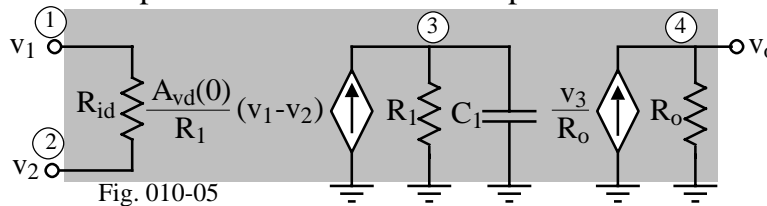

Figure 5 - Frequency dependent model with constant output resistance.

### Example 6.7-2 - Frequency Response of the Noninverting Voltage Amplifier

Use the model of Fig. 4 to find the frequency response of Fig. 2 if the gain is +1, +10, and +100 V/V assuming that  $A_{vd}(0) = 10^5$  and  $\omega_1 = 100$  rads/sec.

#### Solution

The parameters of the model are  $R_2/R_1 = 0, 9, \text{ and } 99$ . Let us additionally select  $R_{id} = 1\text{M}\Omega$  and  $R_o = 100\Omega$ . We will use the circuit of Fig. 2 and insert the model as a subcircuit. The input file for this example is shown below.

#### Example 2

```
VIN 1 0 DC 0 AC 1          R12 32 0 1KOHM          GAVD/RO 0 3 1 2 1000
*Unity Gain Configuration  R22 22 32 9KOHM          R1 3 0 100
XOPAMP1 1 31 21 *Gain of 100 Configuration C1 3 0 100UF
LINFREQOPAMP              XOPAMP3 1 33 23 .ENDS
R11 31 0 15GOHM          LINFREQOPAMP          .AC DEC 10 100 10MEG
R21 21 31 1OHM           R13 33 0 1KOHM          .PRINT AC V(21) V(22) V(23)
*Gain of 10 Configuration R23 23 33 99KOHM       .PROBE
XOPAMP2 1 32 22 .SUBCKT .END
LINFREQOPAMP             LINFREQOPAMP 1 2 3
RID 1 2 1MEGOHM
```

**Example 6.7-2 - Continued**

Figure 6 - Frequency response of the 3 noninverting voltage amplifiers of Ex. 2.

**Behavioral Frequency Model**

Use of Laplace behavioral modeling capability in PSPICE.

GAVD/RO 0 3 LAPLACE {V(1,2)} = {1000/(0.01s+1)}.

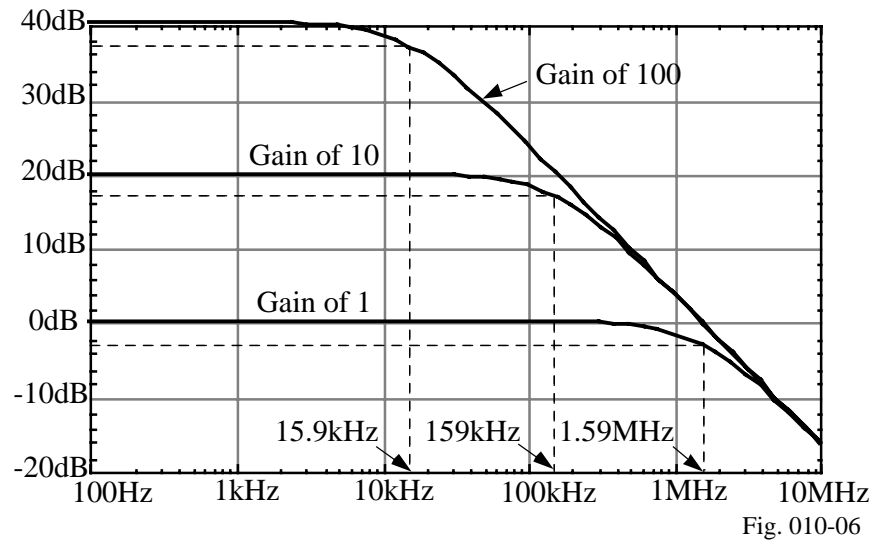
Implements,

$$G_{A_{vd}/R_o} = \frac{A_{vd}(s)}{R_o} = \frac{A_{vd}(0)}{\frac{s}{\omega_1} + 1}$$

where  $A_{vd}(0) = 100,000$ ,  $R_o = 100\Omega$ , and  $\omega_1 = 100$  rps

## Differential and Common Mode Frequency Dependent Models

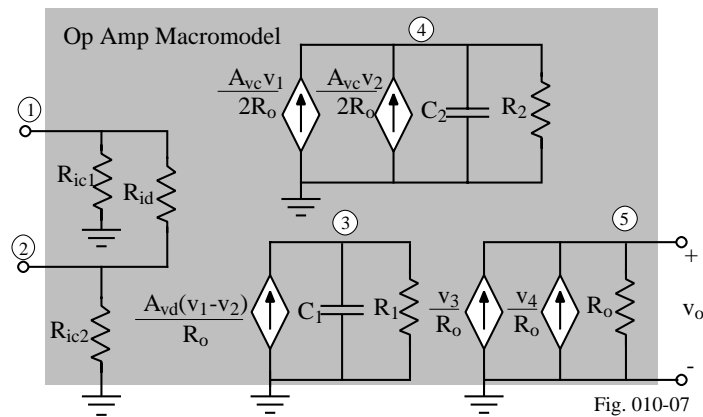

Figure 7 - Op amp macromodel for separate differential and common voltage gain frequency responses.

## Zeros in the Transfer Function

Models:

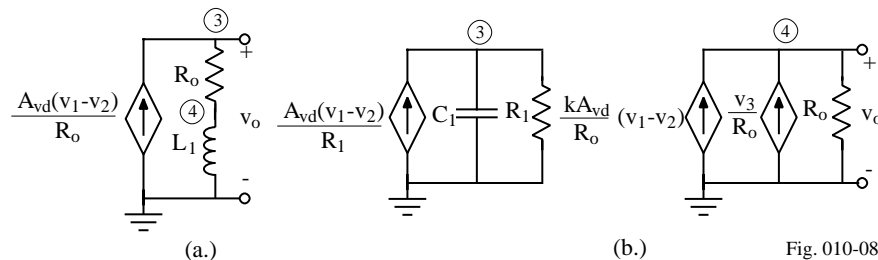

Figure 8 - (a.) Independent zero model. (b.) Method of modeling zeros without introducing new nodes.

Inductor:

$$V_o(s) = \left( \frac{A_{vd}(0)}{R_o} \right) (sL_1 + R_o) [V_1(s) - V_2(s)] = A_{vd}(0) \left( \frac{s}{R_o/L_1} + 1 \right) [V_1(s) - V_2(s)] .$$

Feedforward:

$$V_o(s) = \left( \frac{A_{vd}(0)}{(s/\omega_1) + 1} \right) [1 + k(s/\omega_1) + k] [V_1(s) - V_2(s)] .$$

The zero can be expressed as  $z_1 = -\omega_1 \left( 1 + \frac{1}{k} \right)$

where k can be + or - by reversing the direction of the current source.

### **Example 6.7-3 - Modeling Zeros in the Op Amp Frequency Response**

Use the technique of Fig. 8b to model an op amp with a differential voltage gain of 100,000, a pole at 100rps, an output resistance of 100Ω, and a zero in the right-half, complex frequency plane at 10<sup>7</sup> rps.

#### **Solution**

The transfer function we want to model is given as

$$V_o(s) = \frac{10^5(s/10^7 - 1)}{(s/100 + 1)}$$

Let us arbitrarily select R<sub>1</sub> as 100kΩ which will make the GAVD/R<sub>1</sub> gain unity. To get the pole at 100rps, C<sub>1</sub> = 1/(100R<sub>1</sub>) = 0.1μF. Next, we want z<sub>1</sub> to be 10<sup>7</sup> rps. Since ω<sub>1</sub> = 100rps, then Eq. (6) gives k as -10<sup>-5</sup>. The following input file verifies this model.

```

Example 3
VIN 1 0 DC 0 AC 1
XOPAMP1 1 0 2 LINFREQOPAMP
.SUBCKT LINFREQOPAMP 1 2 4
RID 1 2 1MEGOHM
GAVD/R1 0 3 1 2 1
R1 3 0 100KOHM
C1 3 0 0.1UF
GV3/RO 0 4 3 0 0.01
GAVD/RO 4 0 1 2 0.01
RO 4 0 100
.ENDS
.AC DEC 10 1 100MEG
.PRINT AC V(2) VDB(2) VP(2)
.PROBE
.END

```

### **Example 6.7-3 - Continued**

The asymptotic magnitude frequency response of this simulation is shown in Fig. 9. We note that although the frequency response is plotted in Hertz, there is a pole at 100rps (15.9Hz) and a zero at 1.59MHz (10Mrps). Unless we examined the phase shift, it is not possible to determine whether the zero is in the RHP or LHP of the complex frequency axis.

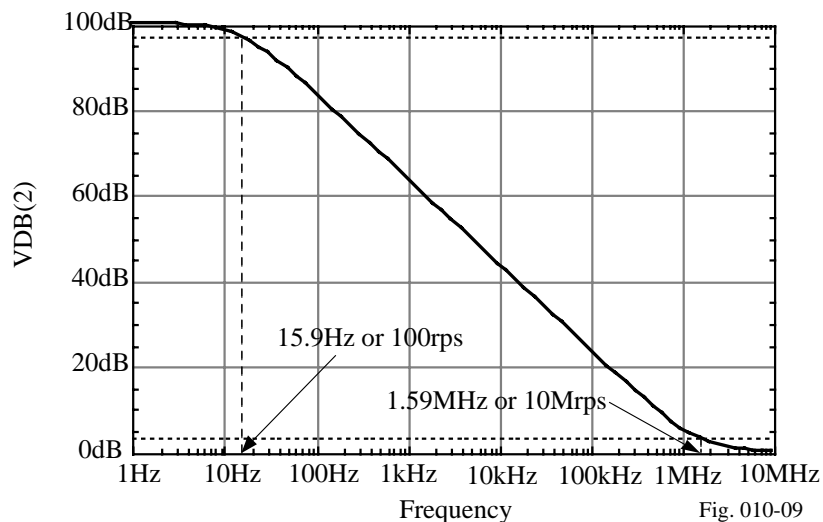

Figure 9 - Asymptotic magnitude frequency response of the op amp model of Ex. 6.7-3.

## Large Signal Macromodels for the Op Amp

### Output and Input Voltage Limitations

Figure 10 - Op amp macromodel that limits the input and output voltages.

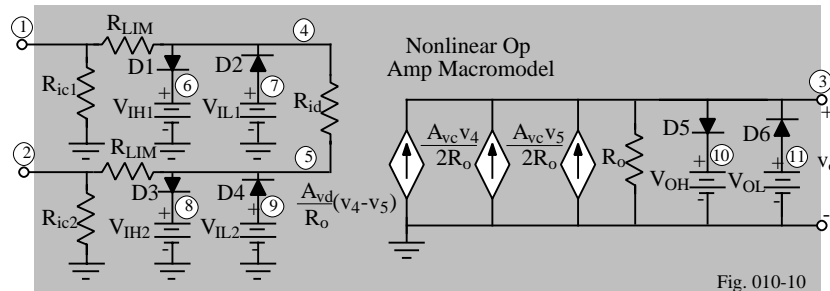

Fig. 010-10

#### Subcircuit Description

```
.SUBCKT NONLINOPAMP 1 2 3
RIC1 1 0 {R_icm}
RLIM1 1 4 0.1
D1 4 6 IDEALMOD
VIH1 6 0 {VIH1}
D2 7 4 IDEALMOD
VIL1 7 0 {VIL1}
RID 4 5 {R_id}
RIC2 2 0 {R_icm}
RLIM2 2 5 0.1
D3 5 8 IDEALMOD
VIH2 8 0 {VIH1}
D4 9 5 IDEALMOD
VIL2 9 0 {VIL2}
GAVD/RO 0 3 4 5 {A_vd/R_o}
GAVC1/RO 0 3 4 0 {A_vc/R_o}
GAVC2/RO 0 3 5 0 {A_vc/R_o}
RO 3 0 {R_o}
D5 3 10 IDEALMOD
VOH 10 0 {VOH}
D6 11 3 IDEALMOD
VOL 11 0 {VOL}
.MODEL IDEALMOD D N=0.001
.ENDS
```

### Example 6.7-4 - Illustration of the Voltage Limits of the Op Amp

Use the macromodel of Fig. 10 to plot  $v_{OUT}$  as a function of  $v_{IN}$  for the noninverting, unity gain, voltage amplifier when  $v_{IN}$  is varied from  $-15V$  to  $+15V$ . The op amp parameters are  $A_{vd}(0) = 100,000$ ,  $R_{id} = 1M\Omega$ ,  $R_{icm} = 100M\Omega$ ,  $A_{vc}(0) = 10$ ,  $R_o = 100\Omega$ ,  $V_{OH} = -V_{OL} = 10V$ ,  $V_{IH1} = V_{IH2} = -V_{IL1} = -V_{IL2} = 5V$ .

#### Solution

The input file for this example is given below.

```
Example 4
VIN 1 0 DC 0
XOPAMP 1 2 2
NONLINOPAMP
.SUBCKT
NONLINOPAMP 1 2 3
RIC1 1 0 100MEG
RLIM1 1 4 0.1
D1 4 6 IDEALMOD
VIH1 6 0 5V
D2 7 4 IDEALMOD
VIL1 7 0 -5V
GAVD/RO 0 3 4 5 1000
GAVC1/2RO 0 3 4 0 0.05
GAVC2/2RO 0 3 5 0 0.05
RO 3 0 100
D5 3 10 IDEALMOD
VOH 10 0 10V
D6 11 3 IDEALMOD
VOL 11 0 -10V
.MODEL IDEALMOD D N=0.0001
.ENDS
.DC VIN -15 15 0.1
.PRINT V(2)
.PROBE
.END
```

**Example 6.7-4 - Illustration of the Voltage Limits of the Op Amp - Continued**

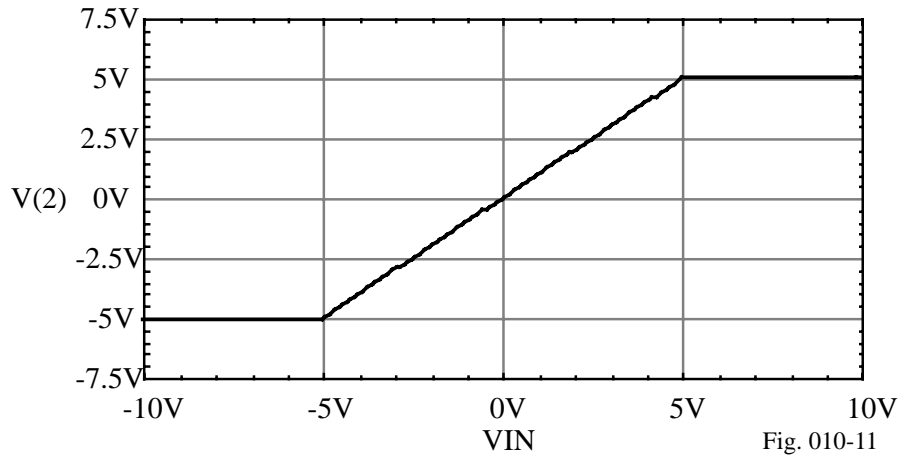
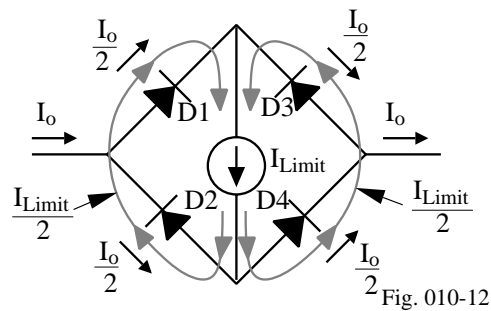

Figure 11 - Simulation results for Ex. 4.

**Output Current Limiting**

Technique:



Macromodel for Output Voltage and Current Limiting:

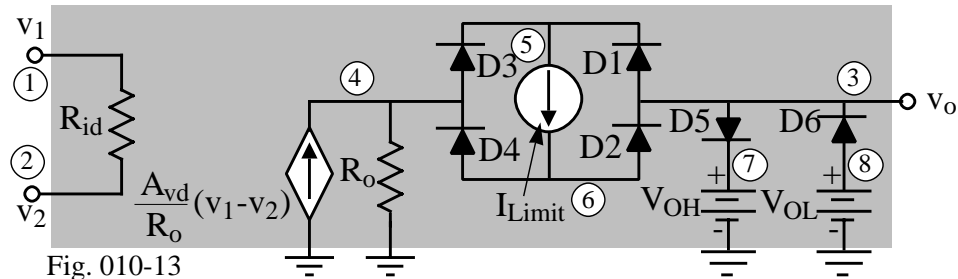

Fig. 010-13

### **Example 6.7-5 - Influence of Current Limiting on the Amplifier Voltage Transfer Curve**

Use the model above to illustrate the influence of current limiting on the voltage transfer curve of an inverting gain of one amplifier. Assume the  $V_{OH} = -V_{OL} = 10V$ ,  $V_{IH} = -V_{IL} = 10V$ , the maximum output current is  $\pm 20mA$ , and  $R_1 = R_2 = R_L = 500\Omega$  where  $R_L$  is a resistor connected from the output to ground. Otherwise, the op amp is ideal.

#### **Solution**

For the ideal op amp we will choose  $A_{vd} = 100,000$ ,  $R_{id} = 1M\Omega$ , and  $R_o = 100\Omega$  and assume one cannot tell the difference between these parameters and the ideal parameters. The remaining model parameters are  $V_{OH} = -V_{OL} = 10V$  and  $I_{Limit} = \pm 20mA$ .

Example 5 - Influence of Current Limiting on the Amplifier Voltage Transfer Curve

```

VIN 1 0 DC 0
R1 1 2 500
R2 2 3 500
RL 3 0 500
XOPAMP 0 2 3 NONLINOPAMP
.SUBCKT NONLINOPAMP 1 2 3
RID 1 2 1MEGOHM
GAVD 0 4 1 2 1000
RO 4 0 100
D1 3 5 IDEALMOD
D2 6 3 IDEALMOD
D3 4 5 IDEALMOD
D4 6 4 IDEALMOD
ILIMIT 5 6 20MA
D5 3 7 IDEALMOD
VOH 7 0 10V
D6 8 3 IDEALMOD
VOL 8 0 -10V
.MODEL IDEALMOD D N=0.00001
.ENDS
.DC VIN -15 15 0.1
.PRINT DC V(3)
.PROBE
.END

```

### **Example 6.7-5 - Continued**

The resulting plot of the output voltage,  $v_3$ , as a function of the input voltage,  $v_{IN}$  is shown in Fig. 14.

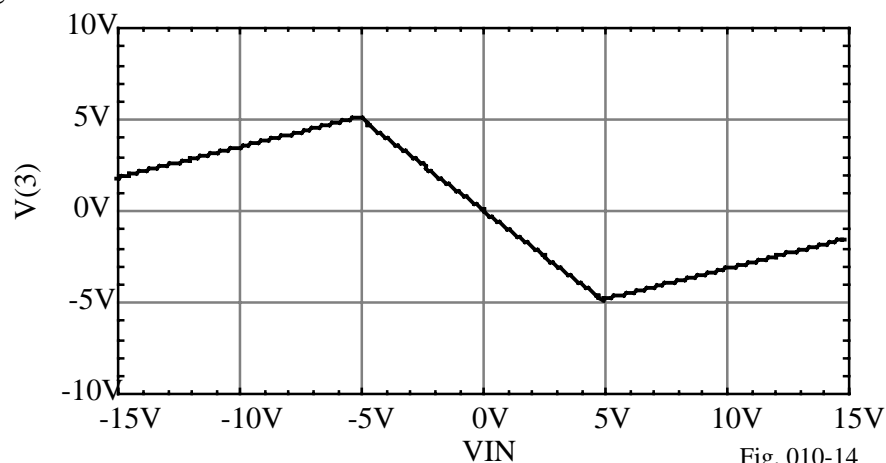

Figure 14 - Results of Example 5.

## Slew Rate Limiting (Time Dependency)

Slew Rate:

$$\frac{dv_o}{dt} = \frac{\pm I_{SR}}{C_1} = \text{Slew Rate}$$

Macromodel:

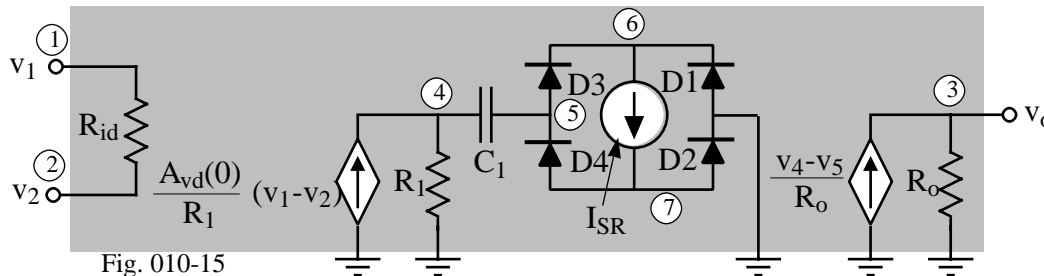

### Example 6.7-6 - Simulation of the Slew Rate of A Noninverting Voltage Amplifier

Let the gain of a noninverting voltage amplifier be 1. If the input signal is given as

$$v_{in}(t) = 10 \sin(4 \times 10^5 \pi t)$$

use the computer to find the output voltage if the slew rate of the op amp is  $10 \text{ V}/\mu\text{s}$ .

#### Solution

We can calculate that the op amp should slew when the frequency is 159kHz. Let us assume the op amp parameters of  $A_{vd} = 100,000$ ,  $\omega_1 = 100 \text{ rps}$ ,  $R_{id} = 1 \text{ M}\Omega$ , and  $R_o = 100 \Omega$ . The simulation input file based on the macromodel of Fig. 15 is given below.

#### Example 6 - Simulation of slew rate limitation

```
VIN 1 0 SIN(0 10 200K)
XOPAMP 1 2 2 NONLINOPAMP
.SUBCKT NONLINOPAMP 1 2 3
RID 1 2 1MEGOHM
GAVD/R1 0 4 1 2 1
R1 4 0 100KOHM
C1 4 5 0.1UF
D1 0 6 IDEALMOD
D2 7 0 IDEALMOD
D3 5 6 IDEALMOD
D4 7 5 IDEALMOD
ISR 6 7 1A
GVO/R0 0 3 4 5 0.01
RO 3 0 100
.MODEL IDEALMOD D N=0.0001
.ENDS
```

**Example 6.7-6 - Continued**

The simulation results are shown in Fig. 16. The input waveform is shown along with the output waveform. The influence of the slew rate causes the output waveform not to be equal to the input waveform.

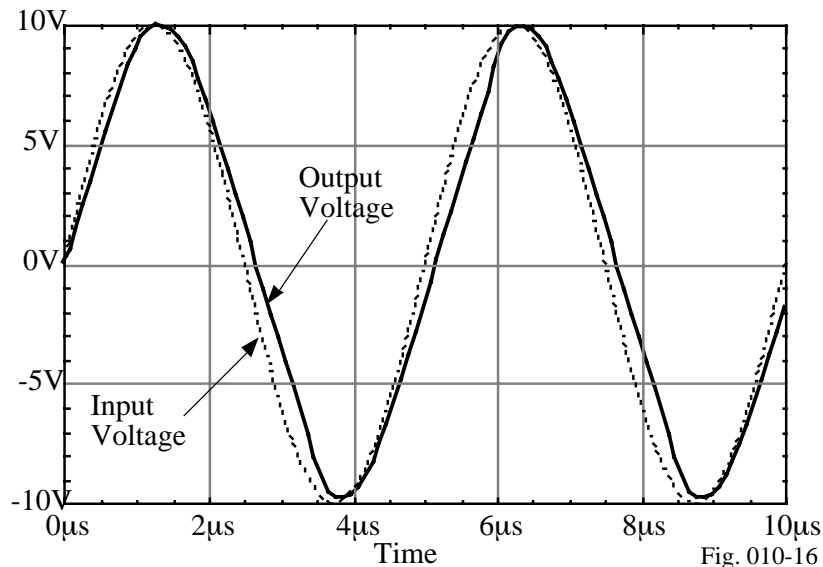

Figure 16 - Results of Ex. 6 on modeling the slew rate of an op amp.

**SPICE Op Amp Library Models**

Macromodels developed from the data sheet for various components.

Key Aspects of Op Amp Macromodels:

- Use the simplest op amp macromodel for a given simulation.
- All things being equal, use the macromodel with the min. no. of nodes.
- Use the SUBCKT feature for repeated use of the macromodel.
- Be sure to verify the correctness of the macromodels before using.
- Macromodels are a good means of trading simulation completeness for decreased simulation time.

## **SECTION 6.8 - SUMMARY**

- Topics
  - Design of CMOS op amps
  - Compensation of op amps
    - Miller
    - Self-compensating
    - Feedforward
  - Two-stage op amp design
  - Power supply rejection ratio of the two-stage op amp
  - Cascode op amps
  - Simulation and measurement of op amps
  - Macromodels of op amps
- Purpose of this chapter is to introduce the simple two-stage op amp to illustrate the concepts of op amp design and to form the starting point for the improvement of performance of the next chapter.
- The design procedures given in this chapter are for the purposes of understanding and applying the design relationships and should not be followed rigorously as the designer gains experience.