

Design of Micropower Operational Amplifiers

by

Surapap Rayanakorn

S.B., Electrical Science and Engineering (2005)
Massachusetts Institute of Technology

Submitted to the Department of Electrical Engineering and Computer Science
in Partial Fulfillment of the Requirements for the Degree of
Master of Engineering in Electrical Engineering and Computer Science
at the

MASSACHUSETTS INSTITUTE OF TECHNOLOGY

June 2006

© 2006 Surapap Rayanakorn. All rights reserved.

The author hereby grants to M.I.T. permission to reproduce and
distribute publicly paper and electronic copies of this thesis
and to grant others the right to do so.

Author.....
Department of Electrical Engineering and Computer Science
May 25, 2006

Certified by.....
Brendan J. Whelan
Design Section Manager
VI-A Company Thesis Supervisor

Certified by.....
Hae-Seung Lee
Professor of Electrical Engineering and Computer Science
M.I.T. Thesis Supervisor

Accepted by.....
Arthur C. Smith
Chairman, Department Committee on Graduate Theses

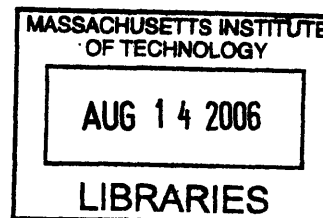

ARCHIVES

Design of Micropower Operational Amplifiers

by

Surapap Rayanakorn

Submitted to the
Department of Electrical Engineering and Computer Science

May 25, 2006

In Partial Fulfillment of the Requirements for the Degree of
Master of Engineering in Electrical Engineering and Computer Science

Abstract

The operational amplifier is a fundamental building block for electronic devices and systems. The advancement of modern electronic technology has been setting more performance demand on the underlying integrated circuits including the operational amplifier. Reduction in power consumption and improvement in speed are some of the most important requirements. To address these concerns, this thesis presents a design of micropower Class AB operational amplifiers which has the ratio of gain bandwidth product to supply current higher than that of an existing IC. The design is in a 0.6 μ m CMOS process. The input stage of the design has the folded-cascode architecture that allows the input common-mode range down to negative supply voltage. The Class AB output stage swings rail-to-rail and has the ratio of maximum current to quiescent current greater than 100. The bias cell of the operational amplifier is designed to consume only 6% of the total supply current. The thesis concludes the operational amplifier design with two frequency compensation options. The one with simple Miller compensation has a unity gain frequency of 360kHz with 61.5 degrees of phase margin at 100pF load while consuming 20 μ A supply current. The other with the hybrid of simple Miller compensation and cascode compensation offers an improved unity gain frequency of 590kHz at the same loading and power condition.

VI-A Company Thesis Supervisor: Brendan J. Whelan
Title: Design Section Manager, Linear Technology Corporation

M.I.T. Thesis Supervisor: Hae-Seung Lee
Title: Professor of Electrical Engineering and Computer Science

Acknowledgements

I am very grateful to Brendan Whelan, my VI-A company thesis supervisor. This project would have been impossible without his supervision. I appreciate his time and patience in guiding me throughout the course of the project. I learned something new every time we talked, and I became a better engineer by working with him. This internship opportunity with him was one of the most rewarding experiences for me. There is nothing more I can ask for from him as a teacher and as a friend.

I would like to thank Professor Harry Lee for supervising the thesis. I learned tremendously from his advice, insightful comments, and his class. His generous support on the thesis is much appreciated.

I would also like to recognize other design managers and engineers at Linear Technology for their technical help. I extend my thanks to Bill Jett and Frank Johnson for their advice on several occasions. I also benefited from the discussions with Brian Hamilton, John Wright, and John Morris.

I would like to acknowledge all the teachers in my life. Particularly, I would like to thank Ajarn Tossaponne Suwannachart for her teaching and constant encouragement during my high school years.

Last but not least, I am forever grateful to my parents and sister. It is impossible to list all the things they have done for me, all the moments we have shared together, and all the contributions they have made to my success. Their unconditional and never-ending love and support are beyond I can thank, and I am blessed to have my family. I am also indebted to my grandparents' love and everything they have contributed to my life. Finally, I would like to extend my gratitude to my aunts, my uncles, and my cousins.

TABLE OF CONTENTS

<u>CHAPTER 1 INTRODUCTION</u>	15
1.1 OVERVIEW OF MICROPOWER OP AMP IN <i>LTC1541</i>	15
1.2 <i>LTC1541</i> LIMITATIONS AND PROBLEM DEFINITION	16
1.3 THESIS GOAL	17
1.4 THESIS ORGANIZATION	19
<u>CHAPTER 2 INPUT STAGE</u>	21
CONSIDERATION OF TRANSISTOR TYPE IN INPUT STAGE	21
2.1 CONSTRAINT 1: INPUT COMMON-MODE RANGE	21
2.2 CONSTRAINT 2: LARGE DC OPEN-LOOP GAIN	25
2.3 CONSTRAINT 3: INPUT OFFSET VOLTAGE	26
<u>CHAPTER 3 OUTPUT STAGE</u>	31
3.1 OUTPUT STAGE BACKGROUND	31
CONFIGURATION OF OUTPUT TRANSISTORS	31
OUTPUT STAGE BIASING	32
DESIRED CHARACTERISTICS OF OUTPUT STAGE	32
3.2 TRANSLINEAR-LOOP-BIASED OUTPUT STAGE	33
QUIESCENT CURRENT	34
MINIMUM CURRENT IN OUTPUT TRANSISTORS	37
MAXIMUM CURRENT IN OUTPUT TRANSISTORS	38
VARIATION OF QUIESCENT CURRENT OVER SUPPLY VOLTAGE RANGE	40
3.3 MODIFIED TRANSLINEAR-LOOP-BIASED OUTPUT STAGE	41
<u>CHAPTER 4 BIAS CELL</u>	45

4.1 REFERENCE CURRENT IN BIAS CORE	45
4.2 START-UP CIRCUIT	48
4.3 REFERENCE VOLTAGES BIAS CIRCUIT	50

CHAPTER 5 FREQUENCY COMPENSATION **55**

5.1 PROPOSED MICROPOWER OP AMP WITH SIMPLE MILLER COMPENSATION (SMC)	55
5.2 CASCODE COMPENSATION	60
5.3 PROPOSED MICROPOWER OP AMP WITH HYBRID ASYMMETRIC EMBEDDED CASCODE COMPENSATION (HAECC)	64

CHAPTER 6 FINAL RESULTS AND CONCLUSION **69**

FINAL RESULTS	69
DISCUSSION	72
FUTURE WORK	74

APPENDICES **75**

APPENDIX A SCHEMATICS AND CHARACTERISTICS OF 20μA MICROPOWER OP AMP WITH SIMPLE MILLER COMPENSATION (SMC)	77
APPENDIX B SCHEMATICS AND CHARACTERISTICS OF 20μA MICROPOWER OP AMP WITH HYBRID EXPLICIT CASCODE COMPENSATION (HECC)	95
APPENDIX C SCHEMATICS AND CHARACTERISTICS OF 20μA MICROPOWER OP AMP WITH HYBRID SYMMETRIC EMBEDDED CASCODE COMPENSATION (HSECC)	113
APPENDIX D SCHEMATICS AND CHARACTERISTICS OF 20μA MICROPOWER OP AMP WITH HYBRID ASYMMETRIC EMBEDDED CASCODE COMPENSATION (HAECC)	131

LIST OF FIGURES

Figure 1-1: Photodiode Amplifier with Single-supply	19
Figure 1-2: Inverting Amplifier with Dual Supplies.....	19
Figure 2-1: Basic Input Stage	22
Figure 2-2: Fully Differential Basic Input Stage [8].....	23
Figure 2-3: Folded-Cascode Input Stage (adapted from [9] to have the PMOS input pair)	24
Figure 2-4: Fully Differential Folded-Cascode Input Stage [9].....	25
Figure 2-5: Input Stage of the Proposed Micropower Op Amp.....	26
Figure 2-6: Input Stage with Transistor Sizes.....	28
Figure 3-1: Complementary Source Follower Configuration [18]	31
Figure 3-2: Complementary Common-Source Configuration [18]	32
Figure 3-3: Translinear-Loop-Biased Class AB Output Stage	34
Figure 3-4: Quiescent Current I_Q vs. Supply Voltage V_{DD} in Translinear-Loop-Biased Output Stage.....	41
Figure 3-5: Modified Translinear-Loop-Biased Class AB Output Stage	42
Figure 3-6: Quiescent Current I_Q vs. Supply Voltage V_{DD} in Modified Translinear-Loop- Biased Output Stage.....	43
Figure 3-7: Currents in Output Pair, I_{DM2P} and I_{DM2N} vs. Load Current I_{LOAD} in Modified Translinear-Loop-Biased Output Stage	43
Figure 4-1: Bias Core Generating Reference Current [25], [26]	46
Figure 4-2: Bias Core with Start-up Circuit.....	48
Figure 4-3: Reference Voltages Set Up in Bias Cell	50
Figure 4-4: Schematic of Bias Cell.....	52
Figure 4-5: I_{REF} , I_{SU} , $V_{NCASCODEB}$, and $V_{PCASCODEB}$ vs. V_{DD}	53
Figure 5-1: Simplified Schematic of Proposed Micropower Op Amp with Simple Miller Compensation (SMC)	57
Figure 5-2: Schematic of Proposed Micropower Op Amp with Simple Miller Compensation (SMC)	58

Figure 5-3: Frequency Response with $C_L=100\text{pF}$ and $R_L=100\text{k}\Omega$ of Proposed Micropower Op Amp with Simple Miller Compensation (SMC)	59
Figure 5-4: Small-Signal Transient Response with $C_L=100\text{pF}$ and $R_L=100\text{k}\Omega$ of Proposed Micropower Op Amp with Simple Miller Compensation (SMC)	59
Figure 5-5: Class A Op Amp with Cascode Compensation (Adapted from [30]).....	61
Figure 5-6: Simplified Schematic of Proposed Micropower Op Amp with Embedded Cascode Compensation (ECC) Only	62
Figure 5-7: Frequency Response with $C_L=100\text{pF}$ and $R_L=100\text{k}\Omega$ of Proposed Micropower Op Amp with Embedded Cascode Compensation (ECC) Only.....	63
Figure 5-8: Frequency Response with $C_L=10\text{pF}$ and $R_L=100\text{k}\Omega$ @ $I_L=-1.0, -0.5, 0.0, 0.5,$ 1.0mA of Proposed Micropower Op Amp with Embedded Cascode Compensation (ECC) Only	63
Figure 5-9: Small-Signal Transient Response with $C_L=100\text{pF}$, $R_L=100\text{k}\Omega$, and $I_L=0.5\text{mA}$ of Proposed Micropower Op Amp with Embedded Cascode Compensation (ECC) Only.....	64
Figure 5-10: Simplified Schematic of Proposed Op Amp with Hybrid Asymmetric Embedded Cascode Compensation (HAECC).....	65
Figure 5-11: Schematic of Proposed Micropower Op Amp with Hybrid Asymmetric Embedded Cascode Compensation (HAECC).....	66
Figure 5-12: Frequency Response with $C_L=100\text{pF}$ and $R_L=100\text{k}\Omega$ of Proposed Micropower Op Amp with Hybrid Asymmetric Embedded Cascode Compensation (HAECC)	67
Figure 5-13: Frequency Response with $C_L=10\text{pF}$ and $R_L=100\text{k}\Omega$ @ $I_L=-1.0, -0.5, 0.0, 0.5,$ 1.0mA of Proposed Micropower Op Amp with Hybrid Asymmetric Embedded Cascode Compensation (HAECC).....	67
Figure 5-14: Small-Signal Transient Response with $C_L=100\text{pF}$, $R_L=100\text{k}\Omega$, and $I_L=0.5\text{mA}$ of Proposed Micropower Op Amp with Hybrid Asymmetric Embedded Cascode Compensation (HAECC).....	68
Figure 6-1: Frequency Response of $20\mu\text{A}$ Micropower Op Amp with HAECC Compensated Down to Have $\Phi_M = 45^\circ$ at 15pF Load to Compare with MAX9914	72

Figure 6-2: Frequency Response of 5 μ A Micropower Op Amp with HAECC
Compensated Down to Have $\Phi_M = 45^\circ$ at 50pF Load to Compare with MIC861 ... 73

LIST OF TABLES

Table 1-1: Electrical Characteristics of <i>LTC1541</i> [1].....	16
Table 1-2: Design Specifications of Micropower Op Amp.....	18
Table 6-1: Characteristics of 20 μ A Micropower Op Amp with Simple Miller Compensation (SMC)	69
Table 6-2: Characteristics of 20 μ A Micropower Op Amp with Hybrid Asymmetric Embedded Cascode Compensation (HAECC).....	70
Table 6-3: Comparison of Unity Gain Frequency between the Proposed 20 μ A Micropower Op Amps and MAX9914	73
Table 6-4: Comparison of Unity Gain Frequency between the Proposed 5 μ A Micropower Op Amps and MIC861	74

Chapter 1 Introduction

The operational amplifier is a fundamental building block in electronics. It is employed in a wide range of applications including monitoring circuitry, cellular phones, portable devices, medical instrumentation, and solar-powered systems [1], [2]. Linear Technology Corporation launched *LTC1541 Micropower Op Amp/Comparator/Reference* in February 1998. The IC has been incorporated in many consumer products such as smoke detectors, infrared receivers, battery-powered systems, and portable phones [1].

1.1 Overview of Micropower Op Amp in *LTC1541*

The micropower op amp, which is part of *LTC1541*, was fabricated in a 4.0 μ m CMOS process. It has a unity-gain frequency of 12kHz while consuming a typical supply current of 1.5 μ A. Electrical characteristics of *LTC1541* with 3V supply voltage at 25 °C from [1] are summarized in Table 1-1.

Specifications are at 25°C. $V_{DD} = 3.0V$ and $V_{SS} = 0V$.						
Primary Characteristics						
Symbol	Parameter	Condition	Value			Unit
			Min	Typical	Max	
GBW ¹	Gain Bandwidth Product	$C_L = 0pF$ $R_L = 100k\Omega$	-	12	-	kHz
A _{VOL}	Large-Signal Voltage Gain (DC Open-Loop Gain)	$C_L = 0pF$ $R_L = 100k\Omega$	93	114	-	dB
I _S	Supply Current	No load	-	1.5	-	μA
V _{INCM}	Input Common-Mode Range	-	V_{SS}	-	$V_{DD} - 1.3V$	V
V _{OS}	Input Offset Voltage	$V_{INCM} = 1.5V$	-	-	0.7	mV
V _{OUT}	V _{OUTH} Output High Voltage	$R_L = 100k\Omega$ to V_{SS}	$V_{DD} - 0.07V$	-	-	V

¹ Implying the gain bandwidth product per supply current $GBW/I_S = 8 \text{ MHz/mA @ } C_L = 0pF$

	V_{OUTL}	Output Low Voltage	$R_L = 100k\Omega$ to V_{DD}	-	-	$V_{SS} + 0.05V$	V
I_{SOURCE}		Output Source Current	-	0.6	0.95	-	mA
I_{SINK}		Output Sink Current	-	1.2	1.8	-	mA
Secondary Characteristics							
Symbol	Parameter	Condition	Value			Unit	
			Min	Typical	Max		
SR	Slew Rate	$A_V = 1V/V$, 1V Step	-	0.008	-	V/ μ s	
CMRR	Common Mode Rejection Ratio	@ DC $V_{INCM} = V_{SS}$ to $V_{DD} - 1.3$	63	-	-	dB	
PSRR	Power Supply Rejection Ratio	@ DC	74	-	-	dB	
e_n	Input Noise Voltage	$f = 0.1$ to 10Hz	-	3	-	μ V _{P-P}	

Table 1-1: Electrical Characteristics of *LTC1541* [1]

1.2 *LTC1541* Limitations and Problem Definition

The standard of electronic equipment and systems has been constantly developing for the past years. This condition has imposed more demanding performance requirements on the supporting semiconductor products, particularly lower power consumption and higher speed. As a result, these foundational integrated circuits including op amps have to continually improve to meet the need.

Currently, there are a few general-purpose low-power op amp ICs in the market. One of them is *MAX9914 1MHz, 20 μ A, Rail-to-Rail I/O Op Amps with Shutdown* by Maxim Integrated Products. It has a 1MHz gain-bandwidth product at 15pF load with 45 degrees of phase margin [3]. Another well-known one is *MIC861 TeenyTM Ultra Low Power Op Amp* by Micrel, Inc. With static supply current of 4.6 μ A, *MIC861* offers a 225kHz gain-bandwidth product at 50pF load with approximately 45 degrees of phase margin² [4].

Although the *Micropower Op Amp* in *LTC1541* consumes an extremely low supply current, its speed is far too low to accommodate the need of modern technologies such as medical instrumentation [5] and portable devices. This thesis seeks to identify

² The phase margin is not given in [4]. It is estimated from the datasheet that the IC has 2-3 periods of decayed oscillation in the small-signal pulse response at 50pF load.

the fundamental limit of speed versus power consumption and propose an improved general-purpose micropower op amp whose speed to supply current ratio is higher than that of *LTC1541*. Other crucial performance specifications are large DC gain and wide input common-mode range that includes the negative supply voltage. In addition, op amp characteristics such as stability, input offset voltage, output swing, and output drive capability have to be considered as well. Some target applications of the new general-purpose low-power op amp include battery-powered systems, portable electronic devices, and safety sensors.

1.3 Thesis Goal

This thesis aims to design a two-stage operational amplifier that satisfies the performance specifications in Table 1-2 and can operate between supply voltages of 2.5V up to 6.0V. The specifications are defined at supply voltage of 2.5V, and they are ordered by their relative importance in the descending order. The first three parameters: unity gain frequency, DC open-loop gain, and supply current, are central in the design process. The other requirements on the primary list must be met, unless their sacrifice exceptionally enhances one of the first three characteristics. The design should also satisfy all the secondary specifications.

Specifications are at 25°C. $V_{DD} = 2.5V$ and $V_{SS} = 0V$.				
Primary Specifications				
Symbol	Parameter	Condition	Value	Unit
GBW^3	Gain Bandwidth Product	$C_L = 100pF$ $R_L = 100k\Omega$	> 0.3	MHz
A_{VOL}	Large-Signal Voltage Gain (DC Open-Loop Gain)	$C_L = 100pF$ $R_L = 100k\Omega$	> 100	dB
I_S	Supply Current	No Load	< 21	μA
V_{INCM}	Input Common-Mode Range	-	> $V_{DD} - 1.25V$ And must include negative supply voltage	V

³ Implying the gain bandwidth product per supply current $GBW/I_S > 14.3 \text{ MHz/mA}$ @ $C_L = 100pF$. Note that GBW/I_S @ $C_L = 0pF$ is going to be higher than that @ $C_L = 100pF$.

V_{OS}	(Untrimmed) Input Offset Voltage		$V_{INCM} = 0.65V$	< 5	mV
V_{OUT}	V_{OUTH}	High Output Voltage	$I_{SOURCE} = 1.0mA$	$> V_{DD} - 0.3V$	V
	V_{OUTL}	Low Output Voltage	$I_{SINK} = 1.0mA$	$< V_{SS} + 0.3V$	V
I_{SOURCE}	Output Source Current		$C_L = 100pF$ $R_L = 100k\Omega$	> 1.0	mA
I_{SINK}	Output Sink Current		$C_L = 100pF$ $R_L = 100k\Omega$	> 1.0	mA
Secondary Specifications					
Symbol	Parameter		Condition	Value	Unit
SR	Slew Rate		$A_V = 1V/V, 1V \text{ Step}$	> 0.15	V/ μ s
CMRR	Common Mode Rejection Ratio		@ DC	> 60	dB
PSRR	Power Supply Rejection Ratio		@ DC	> 60	dB
t_s	0.1% Settling Time		$A_V = 1V/V, 1V \text{ Step}$	< 10	μ s

Table 1-2: Design Specifications of Micropower Op Amp

With these specifications, the new design is expected to be a more versatile low-power general-purpose op amp than the *Micropower Op Amp* in *LTC1541*. The unity-gain frequency is specified to be greater than 300kHz so that the op amp can accommodate a broader range of applications. At this frequency, the op amp has to be properly compensated and well stable with 100pF load.

For supply current, the new op amp must take less than 21 μ A in order to be power-friendly to portable equipment and battery-powered systems. This power restriction implies that the ratio of gain-bandwidth product to supply current has to be greater than 14.3 MHz/mA at 100pF load, which is higher than that of the *Micropower Op Amp* in *LTC1541* or 8 MHz/mA at 0pF load.

Another main specification of the new design is a large DC open-loop gain of more than 100dB. The large DC open-loop gain is important for low-frequency detecting applications such as gas sensors because it minimizes the gain error. Moreover, in these applications, the input voltage is small and a large gain is needed to get a measurable output [6].

The input common-mode range of the new micropower op amp is specified to be wider than half of the supply voltage and must include the negative supply voltage. This specification is imposed because a number of single-supply applications, such as the photodiode amplifier in Figure 1-1, have to take the input at the ground level. In

addition, many dual-supply applications such as the inverting amplifier in Figure 1-2 are often biased at its mid supply voltage or ground [6].

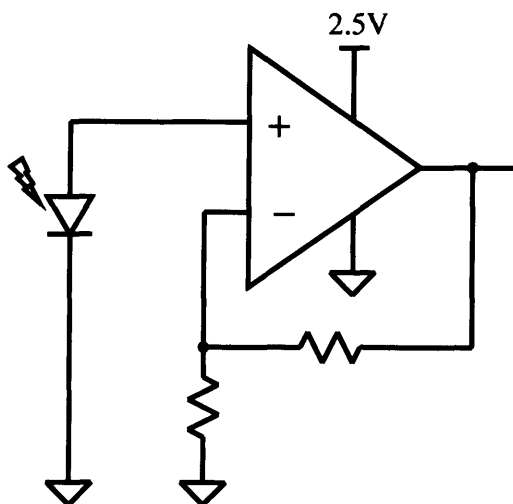

Figure 1-1: Photodiode Amplifier with Single-supply

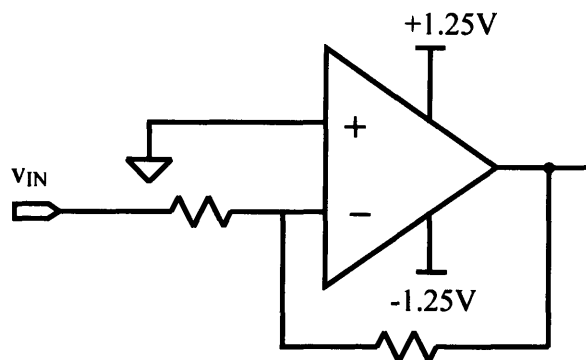

Figure 1-2: Inverting Amplifier with Dual Supplies

1.4 Thesis Organization

Chapter 1 gives an overview of low-power operational amplifiers and their applications, defines the problem of interest, and sets the goal that this thesis seeks to achieve.

The rest of the thesis is organized as follows. Chapter 2 discusses how the target specifications constrain the design of input stage of the micropower op amp, and demonstrates the input stage details resulted from the restrictions. Chapter 3 extensively

describes the output stage. The design of bias cell is presented in Chapter 4. Chapter 5 looks into the limitation on the gain bandwidth product in the context of frequency compensation of two-stage op amps. It then presents the complete micropower op amps, and selected simulation results. Lastly, Chapter 6 discusses the results and concludes the thesis work. In addition, the appendices provide a complete collection of simulation results of the proposed micropower op amp with different frequency compensation schemes.

Chapter 2 Input Stage

This chapter examines a number of common input stages and explains how the input stage design is shaped by the constraints from specification. It first reasons why the PMOS input pair is chosen over the NMOS one. The related constraints, namely input common-mode range, DC open-loop gain, and input offset voltage, are then discussed in the design context. The input common-mode range requirement sketches the preliminary topology of the input stage. The final architecture is the result of the open-loop gain restriction. Lastly, the input offset voltage constraint instructs how the transistors have to be sized.

Consideration of Transistor Type in Input Stage

One of the primary reasons that PMOS transistors are chosen for the input stage is the fact that its input common-mode range includes ground for single-supply operation [6]. There are a number of other benefits for having PMOS transistors as the input stage rather than NMOS transistors [7]. First, PMOS transistors have less $1/f$ noise. Second, a PMOS input stage results in a higher slew rate than an NMOS one.

The following sections explain the design details of input stage based on the consideration of the related constraints: input common-mode range, DC open-loop gain, and input offset voltage.

2.1 Constraint 1: Input Common-Mode Range

One of the primary specifications of the op amp in design is to have the input common-mode range that includes ground for single-supply operation as well as mid-supply voltage for dual-supply operation. This section discusses different input stage architectures and reasons why the single-ended folded-cascode configuration is used as the input stage in the proposed micropower op amp.

Most op amps employ one of the following common topologies or their variants as the input stage: single-ended or fully differential basic input stage, or single-ended or

fully differential folded-cascode input stage. The four common topologies are shown in Figure 2-1, Figure 2-2, Figure 2-3, and Figure 2-4 respectively [8]-[10].

The basic input stage in Figure 2-1 has the maximum common-mode input of $V_{DD} - (V_{SGP} + V_{DS,SAT})$, which is high enough to accommodate mid-supply inputs for dual-supply applications. However, its common-mode range cannot go down to ground for single-supply operation, and therefore does not meet the requirement. The lowest of the input range is only $V_{GSN} - V_{SGP} + V_{DS,SAT}$, which amounts to be approximately $1V_{DS,SAT}$ to $2V_{DS,SAT}$ above the ground (In general, $V_{GSN} > V_{SGP}$ because the input pair is usually weakly inverted due to its large width, but the current mirror transistors are strongly inverted).

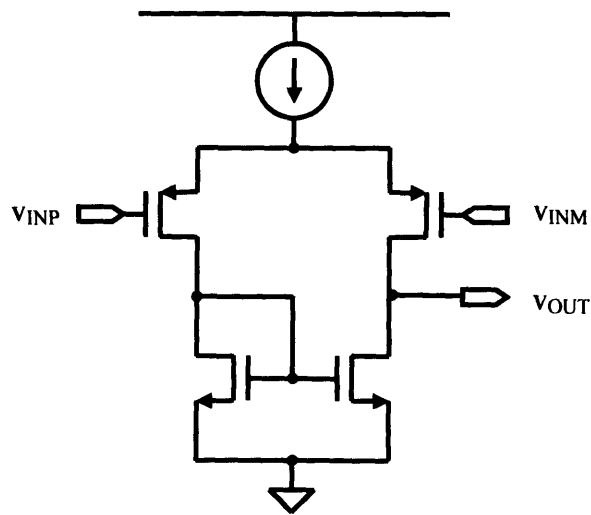

Figure 2-1: Basic Input Stage

The basic input stage may also be implemented as a fully differential architecture shown in Figure 2-2, simplified from [8]. Its common-mode input level can go up to $V_{DD} - V_{SGP} - V_{DS,SAT}$ (same as that of Figure 2-1) and can go down beyond the ground to as low as $2V_{DS,SAT} - V_{SGP}$. Although it satisfies the input common-mode range specification, it requires a common-mode control circuit, which in turn increases power dissipation in the op amp. The second stage must also have differential inputs, which increases the power dissipation even more. These extra implementation costs are its disadvantages, especially for the op amp in design in which the total supply current has to be minimized.

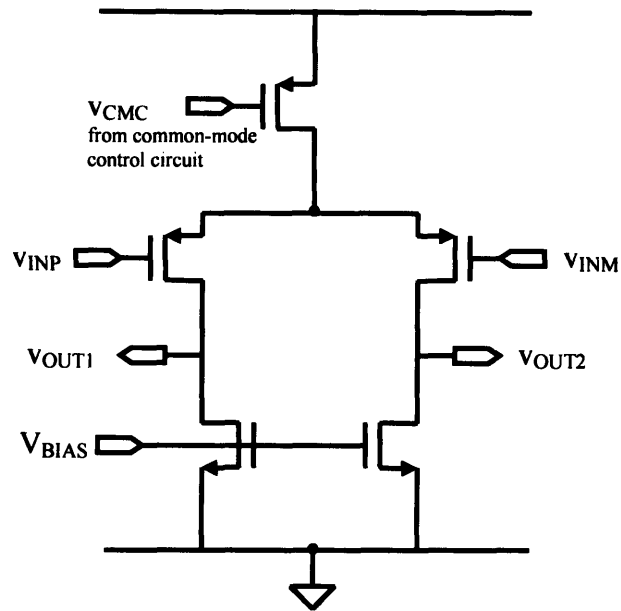

Figure 2-2: Fully Differential Basic Input Stage [8]

The folded-cascode topology in Figure 2-3, adapted from [9] to have the PMOS input pair, has the same input common-mode range as the fully differential basic input stage in Figure 2-2. Therefore, it satisfies the requirement. In addition, its input common-mode range remains the same if a cascode current mirror or a wide-swing current mirror is used instead of the simple current mirror shown in the schematic. The only drawback is it consumes more current than the basic input stage for the same tail current to implement the folded section. However, a wider input common-mode range that includes ground for single-supply operation is more important. The input stage of the proposed micropower op amp is based on this topology.

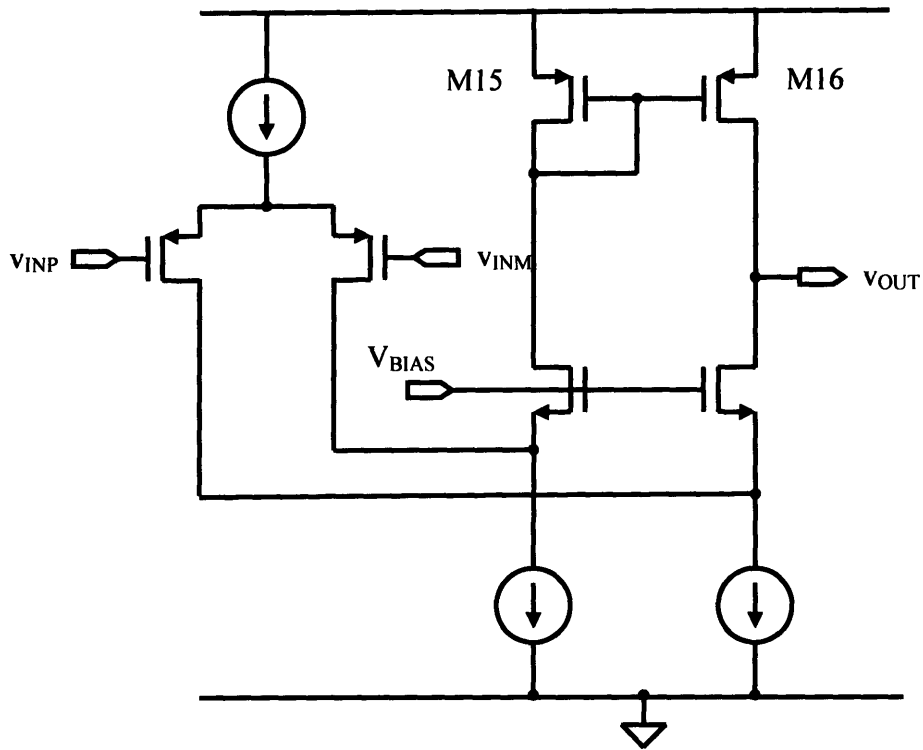

Figure 2-3: Folded-Cascode Input Stage (adapted from [9] to have the PMOS input pair)

The differential form of the folded-cascode input stage is shown in Figure 2-4 [9]. This topology has the same additional implementation need as the differential basic input stage, and therefore is not appropriate for the author's design. Other input stage topologies explored include the complementary input stage in [21]. It allows rail-to-rail inputs. However, it needs a transconductance control circuit to ensure that the input stage has a constant transconductance across all the input range. This additional requirement increases design complexity and results in more power consumption. Therefore, the complementary input stage is not selected for the proposed micropower op amp.

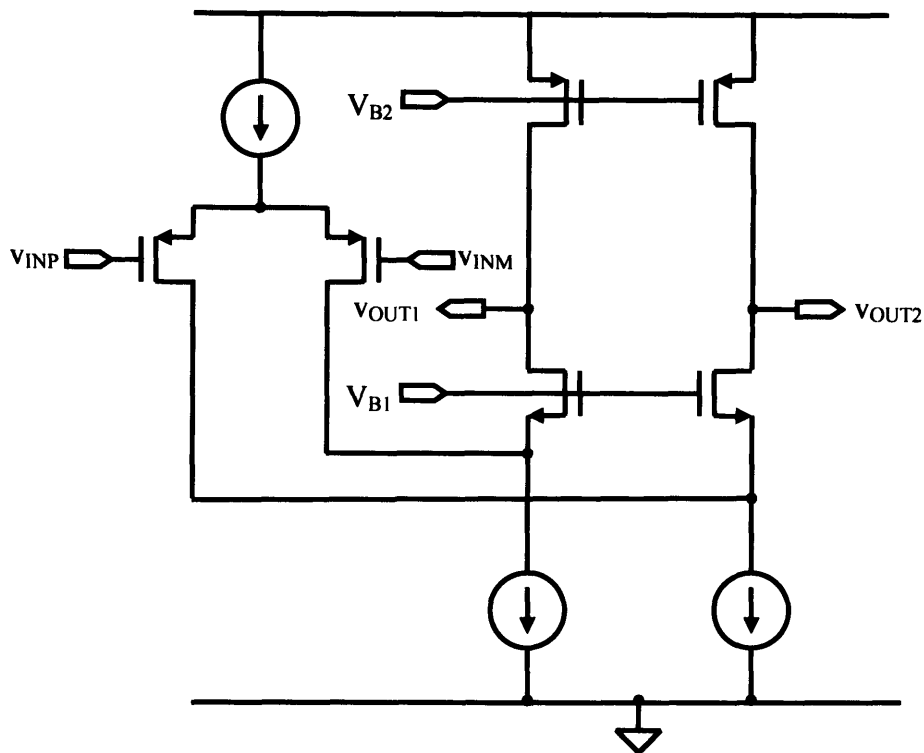

Figure 2-4: Fully Differential Folded-Cascode Input Stage [9]

2.2 Constraint 2: Large DC Open-Loop Gain

The specified DC open-loop gain is at least 100dB. This high DC open-loop gain is one of the design goals because the op amp has to support many applications that require very large gains at low frequencies. These applications include gas sensors and other transducers such as thermocouples, bridges, hall-effect sensors and photodiodes [10]. This high gain characteristic is not easy to achieve in a two-stage op amp.

The simple current mirror in the chosen folded-cascode input stage in Figure 2-3 has low output resistance, compared to Wilson current mirrors and cascode current mirrors, and thus making it more difficult to meet the required DC open-loop gain. In addition, V_{DS} of M16 in the simple current mirror changes with the operating supply voltage and the bias of the output stage, and thus undesirably causing the bias current in M16 to slightly vary upon those condition changes.

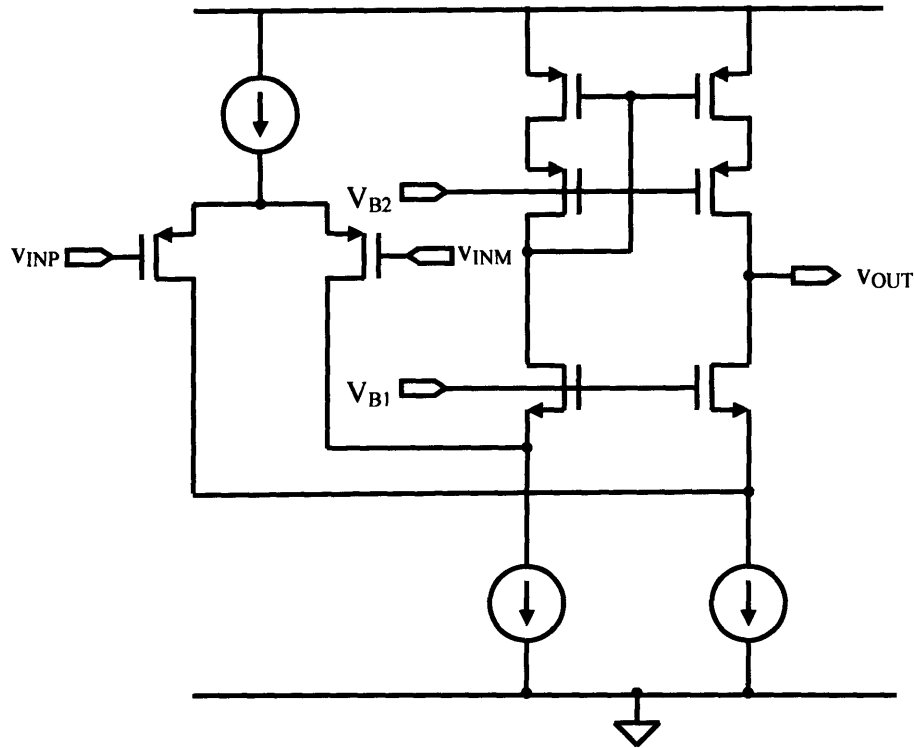

Figure 2-5: Input Stage of the Proposed Micropower Op Amp

The wide-swing current mirror [9] is chosen for the input stage of the proposed op amp as shown in Figure 2-5. It has high output resistance and has the highest bandwidth per drain current ratio after the basic Wilson mirror and the improved Wilson mirror [11]. In addition, the wide-swing current mirror can operate with voltage down to $2V_{SD,SAT}$ across its output side, unlike both forms of Wilson current mirrors and the cascode current mirror that require at least $V_{SG} + V_{SD,SAT}$ across the output side to operate properly, i.e. the transistors stay in the saturation region. With the increased output impedance of the current mirror, the op amp not only has a higher DC gain, but also higher CMRR and PSRR [10].

2.3 Constraint 3: Input Offset Voltage

The input offset voltage comes from two sources. They are systematic offset voltage and random offset voltage [12], [13]. The systematic offset voltage is caused by asymmetry in the op amp architecture. The random offset voltage is the consequence of mismatches in transistor pairs such as the differential input pair. The contribution of the

random offset voltage on the total offset voltage is more significant than that of the systematic offset voltage when the first stage gain is large. This condition is particularly true in the author's design in which most of the op amp gain is from the input stage. (Simulation results show the input stage gain is on the order of 10^4 in the proposed op amp). As a result, only the random offset voltage will be considered in this section.

Transistor pair mismatch comes from the difference in their threshold voltage V_T and current factor β [14]. In general, the variation in the threshold voltage and current factor becomes less as the transistor area increases. The following calculation of input offset voltage for transistor sizing is based on the model in [14] and [15]. The standard deviation of the threshold voltage difference ΔV_T is described by

$$\sigma(\Delta V_T) = \frac{A_{VT}}{\sqrt{WL}}$$

where A_{VT} is a constant depending on the process technology (usually less for smaller processes)

(2-1)

The standard deviation of the relative current factor difference $\frac{\Delta\beta}{\beta}$ is described by

$$\sigma\left(\frac{\Delta\beta}{\beta}\right) = \frac{A_\beta}{\sqrt{WL}}$$

where A_β is a constant depending on the process technology

(2-2)

According to [14], the variance of the gate-source voltage difference in a transistor pair with the same drain current can be described as

$$\sigma^2(V_{OS}) = \frac{1}{WL} \left[A_{VT}^2 + \frac{(V_{GS} - V_T)}{4} A_\beta^2 \right]$$

where V_{OS} is the offset voltage (or gate - source voltage difference of a transistor pair)

(2-3)

Equation (2-3) implies the effect of the current factor mismatch reduces as the overdrive voltage decreases. In almost all circumstances, the threshold mismatch dominates the offset voltage. For a $0.7\mu\text{m}$ CMOS technology, the effect of the threshold mismatch is more significant than the current factor mismatch for overdrive less than 1.4V [14]. In

the author's design where the total supply current is under 20 μ A, most transistor pairs are weakly or moderately inverted. Therefore, the offset voltage can be estimated by only considering the component due to threshold mismatch as

$$\sigma^2(V_{OS}) \approx \frac{A_{VT}^2}{WL} \tag{2-4}$$

This following section explains transistor sizing and input offset voltage consideration.

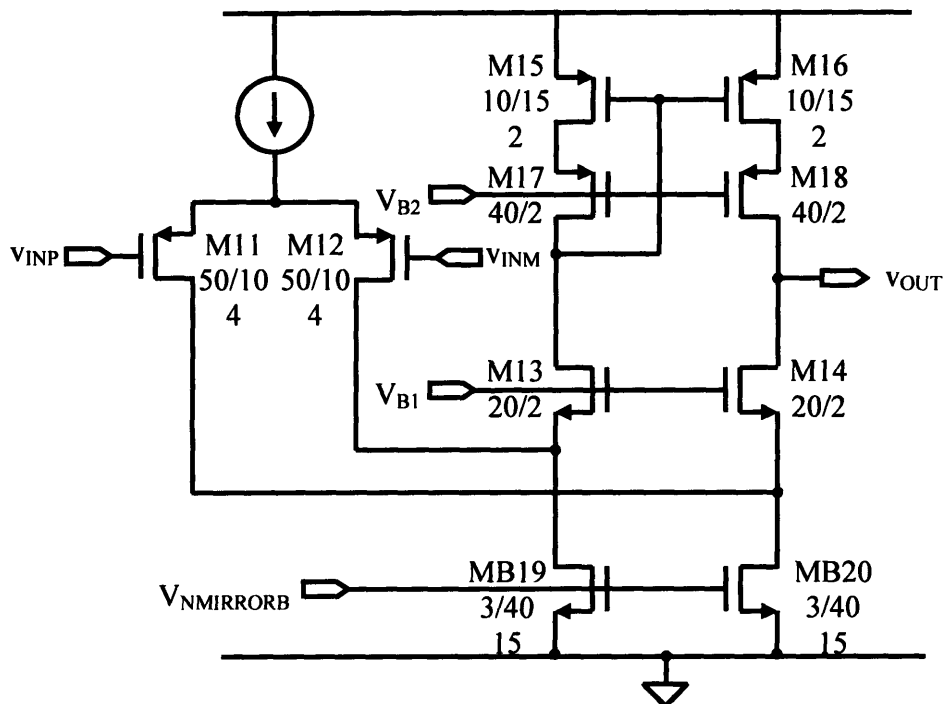

Figure 2-6: Input Stage with Transistor Sizes

The input stage with transistor sizes is depicted in Figure 2-6. The input referred offset voltage is the result of the mismatch in the following 3 transistor pairs: M11-M12, M15-M16, and MB19-MB20. Transistor pairs M17-M18 and M13-M14 do not affect the input offset voltage. It is also not necessary to consider the offset voltage due to any mismatch in the output stage because that offset voltage is divided by the gain of the input stage when referred to the input [10], [14].

The micropower op amp is specified to have an untrimmed input offset voltage of less than 5mV. In order to achieve good yields in IC production, the transistors are sized

such that three standard deviations of input offset voltage is less than 5mV. This condition corresponds to yielding 99.7% of fabricated ICs having untrimmed input offset voltage within +/- 5mV [16]. The transistor sizes in the final input stage design in Figure 2-6 evolve from preliminary hand calculation and simulation. The differential input pair is sized to be very wide for two main reasons. The first goal is to make the input pair having the highest transconductance g_m , compared to other transistor pairs in the input stage, so that the offset voltage due to the other pairs is attenuated as implied by (2-6). The other intention is to keep its gate-source voltage small so that the input common-mode range is increased. For the wide-swing current mirror, transistor pair M15-M16 is sized to be long to get high output impedance. The cascode transistor pair M17-M18 of the mirror is sized to be wide to have high transconductance [10]. The following calculation shows the course of preliminary hand calculation of input offset voltage using the final transistor sizes.

Require $3\sigma(V_{OS}) < 5\text{mV}$

$$\sigma(V_{OS}) < \frac{5}{3} \text{mV}$$

(2-5)

From the input stage in Figure 2 - 6,

$$\sigma(V_{OS}) = \sqrt{\sigma_{11}^2 + \left(\frac{g_{m15}}{g_{m11}}\right)\sigma_{15}^2 + \left(\frac{g_{mB19}}{g_{m11}}\right)\sigma_{B19}^2}$$

(2-6)

From (2-6), the transconductance ratio $\left(\frac{g_{m15}}{g_{m11}}\right)$ and $\left(\frac{g_{mB19}}{g_{m11}}\right)$ will be made to be one to simplify the calculation. Hence, the calculated offset voltage will be an overestimate.

$$\sigma(V_{OS}) = \sqrt{\sigma_{11}^2 + \sigma_{15}^2 + \sigma_{B19}^2}$$

(2-7)

For 0.7 μm CMOS technology [14]⁴,

$$A_{VTP} = 22\text{mV} \cdot \mu\text{m}$$

$$A_{VTN} = 13\text{mV} \cdot \mu\text{m}$$

$$\sigma_{11}^2(\Delta V_{GS}) = \frac{A_{VTP}^2}{(WL)_{11}} = \frac{(22\text{mV} \cdot \mu\text{m})^2}{[4 \cdot (50\mu\text{m}) \cdot (10\mu\text{m})]} = 0.242\text{mV}^2$$

$$\sigma_{15}^2(\Delta V_{GS}) = \frac{A_{VTP}^2}{(WL)_{15}} = \frac{(22\text{mV} \cdot \mu\text{m})^2}{[2 \cdot (10\mu\text{m}) \cdot (15\mu\text{m})]} = 1.61\text{mV}^2$$

$$\sigma_{B19}^2(\Delta V_{GS}) = \frac{A_{VTN}^2}{(WL)_{B19}} = \frac{(13\text{mV} \cdot \mu\text{m})^2}{[15 \cdot (3\mu\text{m}) \cdot (40\mu\text{m})]} = 0.094\text{mV}^2$$

$$\sigma(V_{OS}) = \sqrt{0.242 + 1.61 + 0.094}\text{mV}$$

$$\sigma(V_{OS}) = 1.39\text{mV} < \frac{5}{3}\text{mV}$$

If the input offset voltage were not a concern, the author could size input stage transistors to be extremely small. This sizing would make the parasitic capacitances minimal, so the unity-gain frequency would be higher without any other changes. However, in practice, it is desirable for the op amp to have low input offset voltage, and the input offset voltage specification must be met. Therefore, some transistors in the input stage need to be sized to have large areas as shown in the calculation and Figure 2-6.

⁴ The constant A_{VT} for 0.6 μm CMOS technology was not found in literature, so the one for 0.7 μm CMOS technology is used instead. This choice will result in a conservative estimate of offset voltage because this constant decreases as the process becomes smaller.

Chapter 3 Output Stage

In this chapter, the background on output stages and desired characteristics of the proposed op amp are first explored. Then, the design of the output stage employed in the proposed op amp is explained.

3.1 Output Stage Background

The output stage is needed for op amps that have to drive resistive loads or heavy capacitive loads [17]. This section presents a brief introduction on the configuration of output transistors and the classification of output stage biasing.

Configuration of Output Transistors

The arrangement of the output transistors in an output stage can be classified into two basic configurations. They are complementary source-follower and complementary common-source as shown in Figure 3-1 and Figure 3-2, respectively [18]. Since the proposed micropower op amp needs to have a rail-to-rail output stage, the complementary common-source configuration is used in the design.

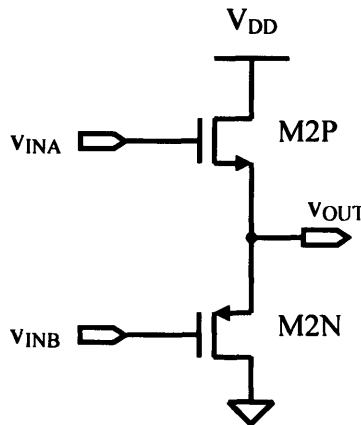

Figure 3-1: Complementary Source Follower Configuration [18]

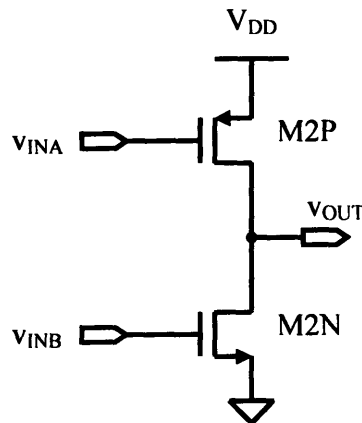

Figure 3-2: Complementary Common-Source Configuration [18]

Output Stage Biasing

The three common biasing schemes for the output stage are Class A, Class B, and Class AB. Class A output stage is easy to implement, but it dissipates power all the time and cannot source or sink current from the load more than its quiescent current value. Class B output stage saves power because it is inactive when there is no signal, but it has crossover distortion when transitioning between the active input ranges of the two devices. Class AB output stage keeps both of the output transistors on with a small amount of biasing current so it does not have the distortion problem [19]. Moreover, it can source or sink current when required by the load.

Desired Characteristics of Output Stage

The output stage of the proposed micropower op amp has to be able to swing rail-to-rail. For the biasing, the output stage should maintain relatively constant quiescent current across the operating supply voltage of 2.5V to 6.0V. Moreover, because of the output source/sink current specification, it needs to have a large ratio of the maximum sourcing/sinking current to the quiescent current. As a result, the output stage of the proposed micropower op amp is in the complementary common-source configuration and is biased by a Class AB scheme described in the next sections.

3.2 Translinear-Loop-Biased Output Stage

The biasing scheme of the proposed op amp output stage evolves from the translinear-loop-biased configuration shown in Figure 3-3. This translinear-loop-biased topology was presented in [20] and extensively investigated in [21]-[22]. It is also called the Yin-Yang output stage due to the symmetry of biasing [23]. This output stage exhibits Class AB characteristics. It can operate down to a supply voltage of $2V_{GS} + 2V_{DS}$ if cascode current sources are used, and down to $2V_{GS} + V_{DS}$ if simple current sources are used. In addition, this output stage topology does not add noise and offset to the op amp, provided that the two current sources biasing the bridging transistors, M23 and M26, are implemented by the existing bias currents in the input stage [21]. The signals from the input stage, v_{inA} and v_{inB} , feed directly to the gate of their respective output transistor and also feed to the other transistor through the bridging transistors, M23 and M26. While M23 and M26 actively bias the output transistors, nodes v_{INA} and v_{INB} are always of high impedance regardless of supply voltage.

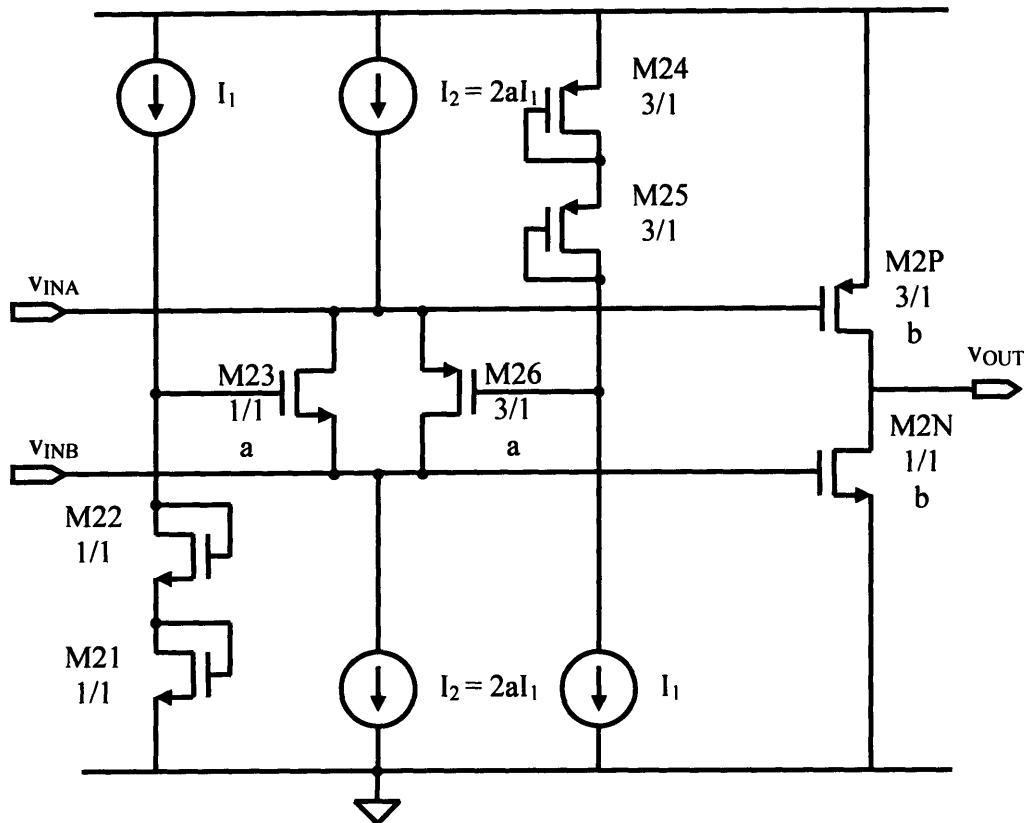

Figure 3-3: Translinear-Loop-Biased Class AB Output Stage

In the NMOS translinear loop, M23 is sized to be a times as wide as M21 and M22 to accommodate I_2 which is $2a$ times as large as I_1 . The output device M2N is sized to be b times as wide as M21 and M22 so that the output pair can sink and source large currents and have high g_m 's. The same geometry guideline applies to the PMOS translinear loop. In addition, PMOS transistors are sized to be 3 times as wide as their NMOS counterparts because the hole mobility is approximately one third of the electron mobility. This decision is made so that PMOS transistors have the same transconductance and the same gate-source voltage as NMOS transistors under the same condition, i.e. equal bias currents [18].

Quiescent Current

When the output stage is at rest, the quiescent current can be calculated from either of the translinear loop. Consider the NMOS translinear loop M21-M22-M23-M2N, the quiescent current is determined as follows, similar to an example in [18].

From the translinear loop,

$$V_{GS21} + V_{GS22} = V_{GS23} + V_{GS2N} \quad (3-1)$$

Since $V_{GS} = V_{TN} + \sqrt{\frac{2I_D}{\mu_n C_{ox} \left(\frac{W}{L}\right)}}$ for NMOS transistors in saturation assuming the effect of

channel length modulation is negligible.

$$V_{TN21} + \sqrt{\frac{2I_{D21}}{\mu_n C_{ox} \left(\frac{W}{L}\right)_{21}}} + V_{TN22} + \sqrt{\frac{2I_{D22}}{\mu_n C_{ox} \left(\frac{W}{L}\right)_{22}}} = V_{TN23} + \sqrt{\frac{2I_{D23}}{\mu_n C_{ox} \left(\frac{W}{L}\right)_{23}}} + V_{TN2N} + \sqrt{\frac{2I_{D2N}}{\mu_n C_{ox} \left(\frac{W}{L}\right)_{2N}}} \quad (3-2)$$

Since $V_{TN21} = V_{TN2N}$ and $V_{TN22} \approx V_{TN23}$

$$(3-4)$$

(Note that $V_{TN22} > V_{TN21}$. The body effect causes $V_{TN22} > V_{TN0}$ because $V_{SB22} > 0V$).

$$\sqrt{\frac{I_{D21}}{\left(\frac{W}{L}\right)_{21}}} + \sqrt{\frac{I_{D22}}{\left(\frac{W}{L}\right)_{22}}} = \sqrt{\frac{I_{D23}}{\left(\frac{W}{L}\right)_{23}}} + \sqrt{\frac{I_{D2N}}{\left(\frac{W}{L}\right)_{2N}}} \quad (3-5)$$

$$\sqrt{I_{D2N}} = \sqrt{\left(\frac{W}{L}\right)_{2N}} \left[\sqrt{\frac{I_{D21}}{\left(\frac{W}{L}\right)_{21}}} + \sqrt{\frac{I_{D22}}{\left(\frac{W}{L}\right)_{22}}} - \sqrt{\frac{I_{D23}}{\left(\frac{W}{L}\right)_{23}}} \right] \quad (3-6)$$

$$I_{D2N} = \left(\frac{W}{L}\right)_{2N} \left[\sqrt{\frac{I_{D21}}{\left(\frac{W}{L}\right)_{21}}} + \sqrt{\frac{I_{D22}}{\left(\frac{W}{L}\right)_{22}}} - \sqrt{\frac{I_{D23}}{\left(\frac{W}{L}\right)_{23}}} \right]^2 \quad (3-7)$$

$$I_{D2N} = \frac{\left(\frac{W}{L}\right)_{2N}}{\left(\frac{W}{L}\right)_{21}} \left[\sqrt{I_{D21}} + \sqrt{I_{D22}} - \sqrt{\frac{I_{D23}}{a}} \right]^2 \quad (3-8)$$

In the quiescent state, half of I_2 flows through M23 and the other half goes through M26.

$$I_Q = I_{D2N} = b \left[2\sqrt{I_1} - \sqrt{\frac{I_2}{a}} \right]^2 \quad (3-9)$$

Since $I_2 = 2aI_1$,

$$\boxed{I_Q = I_{D2N} = bI_1} \quad (3-10)$$

(3-11)

The conclusion is the same for the PMOS translinear loop because of the symmetry. The actual quiescent current may slightly differ from (3-11) from two causes. The first one is all the transistors do not have the same V_{DS} 's, but the effect of channel length modulation is ignored in the derivation. The other error source contributes to the deviation from calculation if the transistors are not well in strong inversion. This deviation is particularly true in the author's design because the currents of the translinear transistors (except the output pair) are only in the range of 0.2 – 2.0 μ A. Although the transistors have $V_{GS} > V_{TN}$, their overdrive voltages are less than 50mV, and thus operate in moderate inversion. From the simulation of one of the proposed op amps in Figure 3-6, the quiescent current is found to be within 11% of the calculated value, i.e. the simulated quiescent current is 8.33 μ A at $V_{DD} = 2.5$ V while the calculated value is 9.85 μ A.

As far as the current allocation is concerned, the total supply current should be invested in the output pair transistors as much as possible so that the output stage transconductance, g_{m2} , is high. This design choice is made in order to put the op amp's second pole location as high as possible. However, the remaining current has to be enough for the first stage for two reasons. One is the tail current of the differential pair

input cannot be too small, otherwise the slew rate is too low. The other need is the summing current mirror in the input stage has to be high enough so that the mirror pole does not affect the op amp frequency response near the crossover point. In the proposed op amps, the author distributes approximately half of the total current in the output pair transistors, and verifies by simulation that the current left for the first stage after the bias cell and the biasing of the output stage is sufficient.

Minimum Current in Output Transistors

When the load requires the op amp to source or sink current, one of the output pair transistors is driven hard while the other is retained active with a small bias current. For example, if the load draws current from the output stage, V_{SG2P} increases to allow more drain current in M2P. As a result, V_{SG26} reduces, following the translinear relation $V_{SG24} + V_{SG25} = V_{SG26} + V_{SG2P}$, because V_{SG24} and V_{SG25} are fixed by bias current I_1 . Therefore, more of bias current I_2 flows through M23. When all of I_2 goes through M23, M2N is biased with the minimum current rather than turns off as in the Class B output stage.

The following calculation for the minimum current is done for M2N, but the same result also applies to M2P in the opposite scenario [18].

Consider NMOS translinear loop M21-M22-M23-M2N.

$$\text{From (3-8), } I_{D2N} = \frac{\left(\frac{W}{L}\right)_{2N}}{\left(\frac{W}{L}\right)_{21}} \left[\sqrt{I_{D21}} + \sqrt{I_{D22}} - \sqrt{\frac{I_{D23}}{a}} \right]$$

The minimum current in M2N occurs when all I_2 goes through M23.

$$I_{MIN} = I_{D2N} = b(2\sqrt{I_1} - \sqrt{2I_1})^2 \tag{3-12}$$

$$I_{MIN} = I_{D2N} = (2 - \sqrt{2})^2 bI_1 \tag{3-13}$$

Since $I_Q = bI_1$

$$\boxed{I_{MIN} = I_{D2N} = (2 - \sqrt{2})^2 I_Q}$$

(3-14)

$$I_{MIN} = I_{D2N} = 0.343I_Q$$

In this proposed micropower op amp, the minimum current in the output transistors is close to $0.46I_Q$ according to the simulation result in Figure 3-7. This difference from the calculation is caused by the fact that the transistors in the translinear loops are in moderate inversion because of very low bias currents.

Maximum Current in Output Transistors

The maximum current is defined to be the maximum current that one of the output transistors is capable of sourcing/sinking current while the other output transistor is biased with the minimum current (rather than being turned off). To continue the analysis from the minimum current section, the following absolute maximum current calculation is performed for M2P [18], [23]. Again, the same result applies to M2N as well.

When M2N is biased at the minimum current, all of I_2 flows through M23. V_{G2P} is pulled down to V_{G2N} by M23, and it can be pulled down to be as low as $V_{G2N} + V_{DS,SAT23}$ at most (to allow M23 to remain in saturation). The lowest gate voltage of M2P is described by the following equation.

$$V_{GS21} + V_{GS22} - V_{GS23} + V_{DS,SAT23} = V_{G2P} \quad (3-15)$$

Under this condition, V_{SG2P} is the largest and M2P conducts the maximum current. The source-gate voltage of M2P can be expressed as.

$$V_{SG2P} = V_{DD} - (V_{GS21} + V_{GS22} - V_{GS23} + V_{DS,SAT23}) \quad (3-16)$$

Rewrite V_{SG} and V_{GS} in terms of V_{TP} , V_{TN} , and I_D .

$$-V_{TP2P} + \sqrt{\frac{2(-I_{D2P})}{\mu_p C_{ox} \left(\frac{W}{L}\right)_{2P}}} =$$

$$V_{DD} - \left(V_{TN21} + \sqrt{\frac{2I_{D21}}{\mu_n C_{ox} \left(\frac{W}{L}\right)_{21}}} + V_{TN22} + \sqrt{\frac{2I_{D22}}{\mu_n C_{ox} \left(\frac{W}{L}\right)_{22}}} - V_{TN23} - \sqrt{\frac{2I_{D23}}{\mu_n C_{ox} \left(\frac{W}{L}\right)_{23}}} + V_{DS,SAT23} \right) \quad (3-17)$$

Since $V_{TN22} = V_{TN23}$

$$-V_{TP2P} + \sqrt{\frac{2(-I_{D2P})}{\mu_p C_{ox} \left(\frac{W}{L}\right)_{2P}}} =$$

$$V_{DD} - \left(V_{TN21} + \sqrt{\frac{2I_{D21}}{\mu_n C_{ox} \left(\frac{W}{L}\right)_{21}}} + \sqrt{\frac{2I_{D22}}{\mu_n C_{ox} \left(\frac{W}{L}\right)_{22}}} - \sqrt{\frac{2I_{D23}}{\mu_n C_{ox} \left(\frac{W}{L}\right)_{23}}} + V_{DS,SAT23} \right) \quad (3-18)$$

$$\sqrt{\frac{2(-I_{D2P})}{\mu_p C_{ox} \left(\frac{W}{L}\right)_{2P}}} =$$

$$V_{DD} + V_{TP2P} - V_{TN21} - V_{DS,SAT23} - \left(\sqrt{\frac{2I_{D21}}{\mu_n C_{ox} \left(\frac{W}{L}\right)_{21}}} + \sqrt{\frac{2I_{D22}}{\mu_n C_{ox} \left(\frac{W}{L}\right)_{22}}} - \sqrt{\frac{2I_{D23}}{\mu_n C_{ox} \left(\frac{W}{L}\right)_{23}}} \right) \quad (3-19)$$

Use the approximation,

$$\mu_p C_{ox} = \frac{1}{3} \mu_n C_{ox}$$

$$\sqrt{2(-I_{D2P})} = \sqrt{\mu_p C_{ox} \left(\frac{W}{L}\right)_{2P}} (V_{DD} + V_{TP2P} - V_{TN21} - V_{DS,SAT23}) - \left(\sqrt{2bI_{D21}} + \sqrt{2bI_{D22}} - \sqrt{\frac{2bI_{D23}}{a}} \right) \quad (3-20)$$

$$\sqrt{2(-I_{D2P})} = \sqrt{\mu_p C_{ox} \left(\frac{W}{L}\right)_{2P}} (V_{DD} + V_{TP2P} - V_{TN21} - V_{DS,SAT23}) - \left(2\sqrt{2bI_1} - \sqrt{\frac{2b(2aI_1)}{a}} \right) \quad (3-21)$$

$$I_{MAX} = -I_{D2P} = \frac{1}{2} \left[\sqrt{\mu_p C_{ox} \left(\frac{W}{L} \right)_{2P}} (V_{DD} + V_{TP2P} - V_{TN21} - V_{DS,SAT23}) - (2\sqrt{2bI_1} - 2\sqrt{bI_1}) \right]^2 \quad (3-22)$$

$$I_{MAX} = -I_{D2P} = \frac{1}{2} \left[\sqrt{\mu_p C_{ox} \left(\frac{W}{L} \right)_{2P}} (V_{DD} + V_{TP2P} - V_{TN21} - V_{DS,SAT23}) - 2\sqrt{bI_1}(\sqrt{2} - 1) \right]^2 \quad (3-23)$$

For the following parameter values,

$$V_{DD} = 2.5\text{V}$$

$$V_{TP2P} = -0.9\text{V (typical value from [24])}$$

$$V_{TN21} = 0.8\text{V (typical value from [24])}$$

$$I_1 = 0.2\mu\text{A}$$

$$a = 5, \text{ and } b = 50$$

and $V_{DS,SAT23}$ is approximated to be 0.1V (because it is moderately inverted).

The maximum current, I_{MAX} , calculated from (3-23) is found to be 0.98mA while the simulated I_{MAX} is approximately 1.1mA as shown in Figure 3-7. At this point, the minimum bias current in M2N is down to approximately 3 μ A. This result indicates that the ratio of the maximum current to the quiescent current is 133.

As (3-23) implies, the maximum current increases as the supply voltage goes up. The derivation also applies to the case when M2N conducts I_{MAX} and M2P is biased with I_{MIN} .

Variation of Quiescent Current over Supply Voltage Range

The translinear-loop-biased topology in Figure 3-3 is a robust Class AB output stage, but it has a minor problem. The output pair quiescent current increases as the supply voltage increases. This variation is due to the effect of the channel-length modulation. Consider the NMOS translinear loop, M21-M22-M23-M2N, M21 and M22 have the same V_{DS} regardless of the supply voltages because their gate and drain are connected together. However, V_{DS23} and V_{DS2N} become larger as the supply voltage increases. For M23, as V_{DS23} goes up with supply voltage but the bias current is the same, V_{GS23} becomes slightly smaller. As a result, V_{GS2N} is slightly larger at a higher supply

voltage because the available voltage for M23 and M2N, which is set up by M21 and M22 is the same. Together with the increase in V_{DS} , M2N conducts more quiescent current at higher supply voltages. The same observation is also true for the PMOS translinear loop. The simulation in Figure 3-4 shows as much as 47% increase in I_Q when V_{DD} goes up from 2.5V to 6.0V.

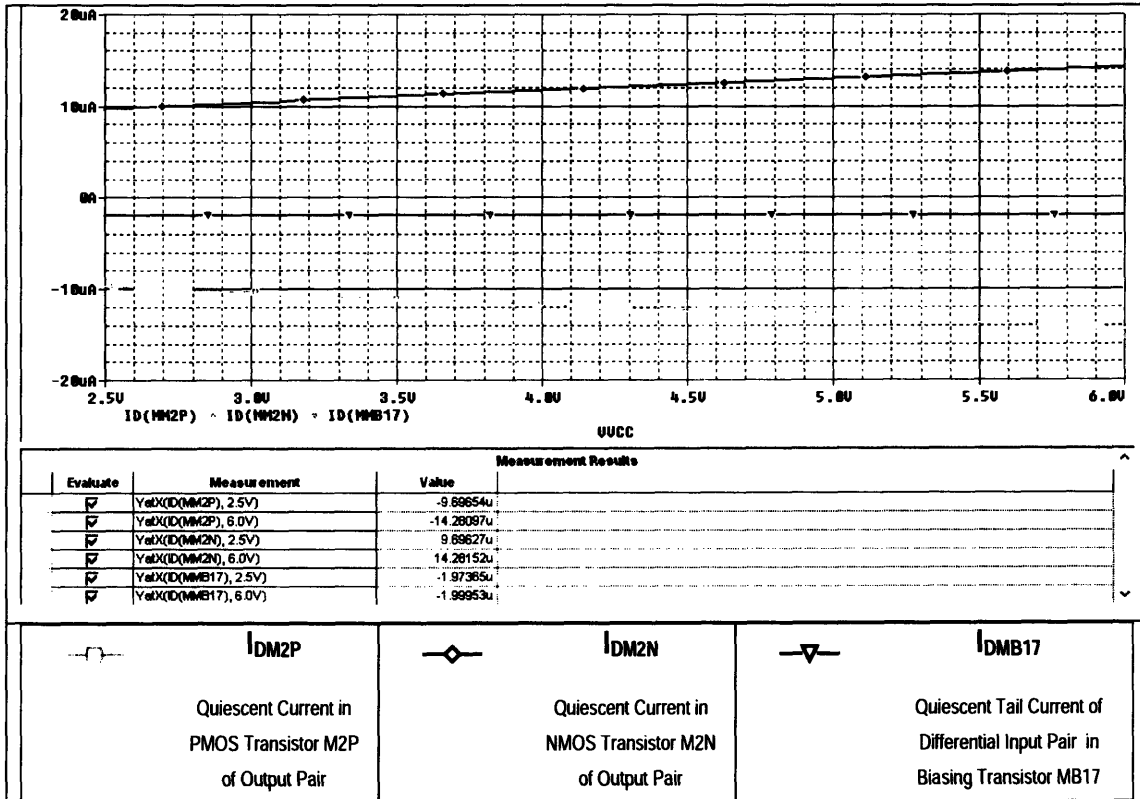

Figure 3-4: Quiescent Current I_Q vs. Supply Voltage V_{DD} in Translinear-Loop-Biased Output Stage

3.3 Modified Translinear-Loop-Biased Output Stage

The modified configuration shown in Figure 3-5 mitigates the variation in the quiescent current over the supply voltage change. It is the topology used in the proposed micropower op amp. This modified biasing scheme alleviates the change in I_Q at a small cost of extra bias currents.

The variation in I_Q is reduced by allowing V_{DS22} and V_{SD25} to increase with the supply voltage [23]. V_{GS22} and V_{SG25} then become slightly lower as the supply voltage increases, thereby leaving less voltage available for M23 and M2N, and M25 and M2P,

respectively. This effect counters the increase in V_{DS23} and V_{SD26} , and thus keeps V_{GS2N} and V_{SG2P} more constant over the supply voltage change. The simulation result in Figure 3-6 shows the variation in I_Q is down to only 20% with the supply voltage change from 2.5V to 6.0V.

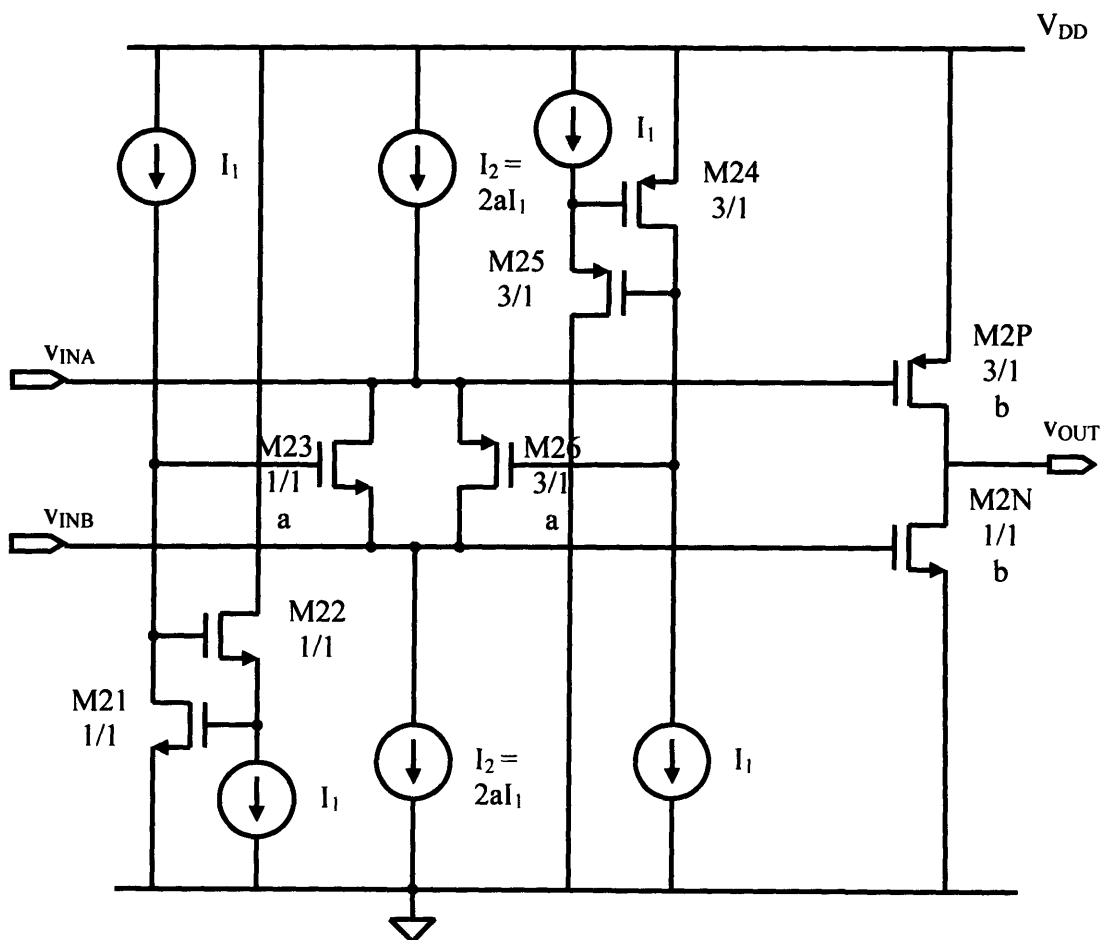

Figure 3-5: Modified Translinear-Loop-Biased Class AB Output Stage

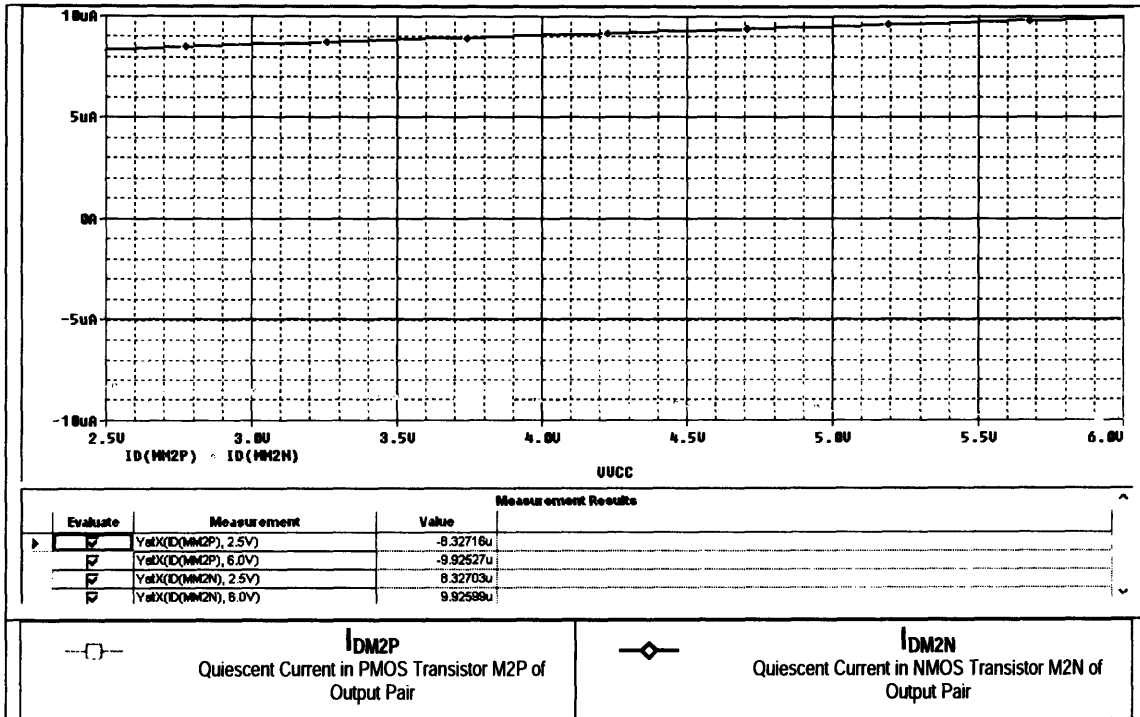

Figure 3-6: Quiescent Current I_Q vs. Supply Voltage V_{DD} in Modified Translinear-Loop-Biased Output Stage

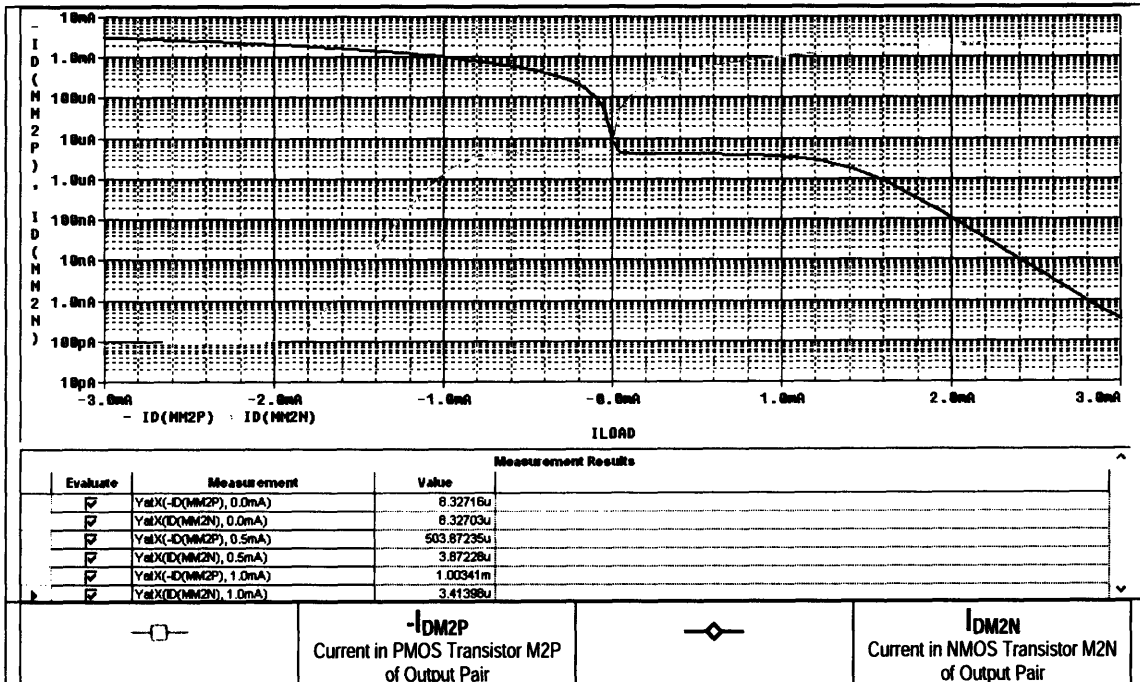

Figure 3-7: Currents in Output Pair, I_{DM2P} and I_{DM2N} vs. Load Current I_{LOAD} in Modified Translinear-Loop-Biased Output Stage

Chapter 4 Bias Cell

This chapter demonstrates the design of the bias cell used in the proposed op amp. It explains how the reference current and reference voltages are generated and passed on to the op amp. The need and the implementation of the start-up circuit in the bias cell are also explained.

4.1 Reference Current in Bias Core

The bias cell core is implemented by the bipolar Widlar current source in Figure 4-1 [25], [26]. Transistor QB2's emitter area is N times as large as that of transistor QB1. In this design, N is chosen to be 5, which is the minimum of emitter area ratio normally used. The reference current is generated by the base emitter voltage difference between QB1 and QB2 across resistor R_B . Note that transistors QB1 is in the forward active region because QB1 is diode-connected. At the minimum supply voltage of 2.5V, QB2 is also in the forward active region because $V_{CEB2} = V_{DD} - V_{SGMB2} - I_{REF}R_B$, which is greater than $V_{CE.SAT}$ if the V_{SGMB2} and the drop across R_B are not too high.

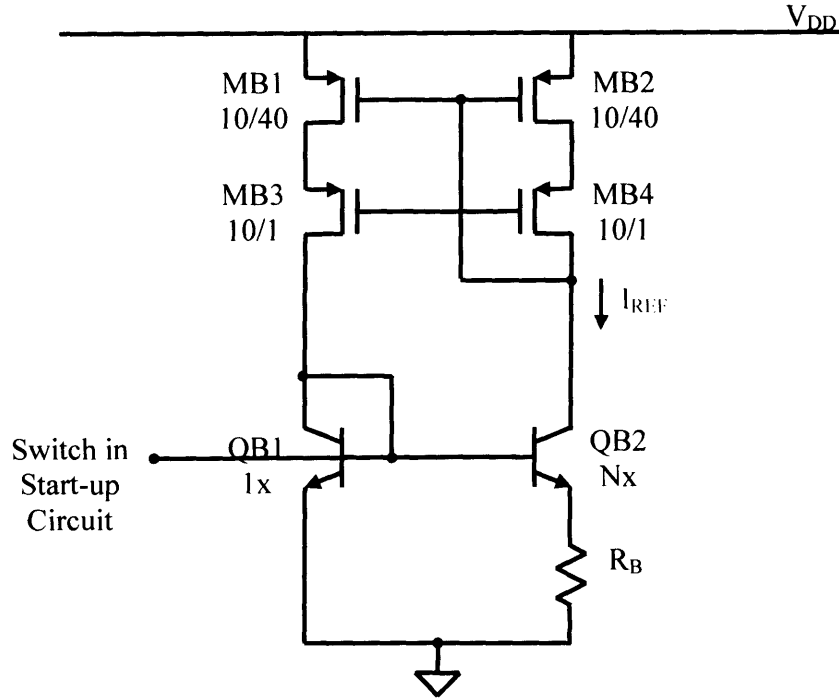

Figure 4-1: Bias Core Generating Reference Current [25], [26]

The reference current, I_{REF} , can be determined by starting from the KVL equation of the QB1-QB2- R_B loop, as presented in [26].

$$V_{BE1} - V_{BE2} - \frac{\beta_F + 1}{\beta_F} I_{REF} R_B = 0 \quad (4-1)$$

Find V_{BE} in terms of I_C .

$$\text{Since } I_C = I_S \left(1 + \frac{V_{CE}}{V_A} \right) e^{\frac{V_{BE}}{V_T}}, \text{ and assume } V_A \gg V_{CE} \text{ [27]} \quad (4-2)$$

$$I_C = I_S e^{\left(\frac{V_{BE}}{V_T} \right)}, \text{ where } V_T = 26\text{mV at } 300\text{K} \quad (4-3)$$

$$\text{Therefore, } V_{BE} = V_T \ln \left(\frac{I_C}{I_S} \right) \quad (4-4)$$

$$V_T \ln \frac{I_{C1}}{I_{S1}} - V_T \ln \frac{I_{REF}}{I_{S2}} - \frac{\beta_F + 1}{\beta_F} I_{REF} R_B = 0$$

(4-5)

Since $\beta_F \gg 1$, $\frac{\beta_F + 1}{\beta_F} \approx 1$

(4-6)

$$V_T \ln \frac{I_{C1}}{I_{S1}} - V_T \ln \frac{I_{REF}}{I_{S2}} - I_{REF} R_B = 0$$

(4-7)

$$V_T \ln \frac{NI_{C1}}{I_{REF}} - I_{REF} R_B = 0$$

(4-8)

$$\boxed{I_{REF} = \frac{V_T}{R_B} \ln N}$$

(4-9)

This result implies the bias cell's ability to provide a constant reference current under process variation. From (4-9), the mismatch in the emitter area ratio ΔN from process shifts is reduced to $\ln(\Delta N)$. Hence, the remaining source for error is the resistor R_B value ($\pm 25\%$ maximum) which can be reduced by adding a trimming resistor [25]. The current mirror transistors are sized to have the width of $10\mu\text{m}$ and the length of $40\mu\text{m}$ so that they have a reasonable area and the mismatch is minimal.

4.2 Start-Up Circuit

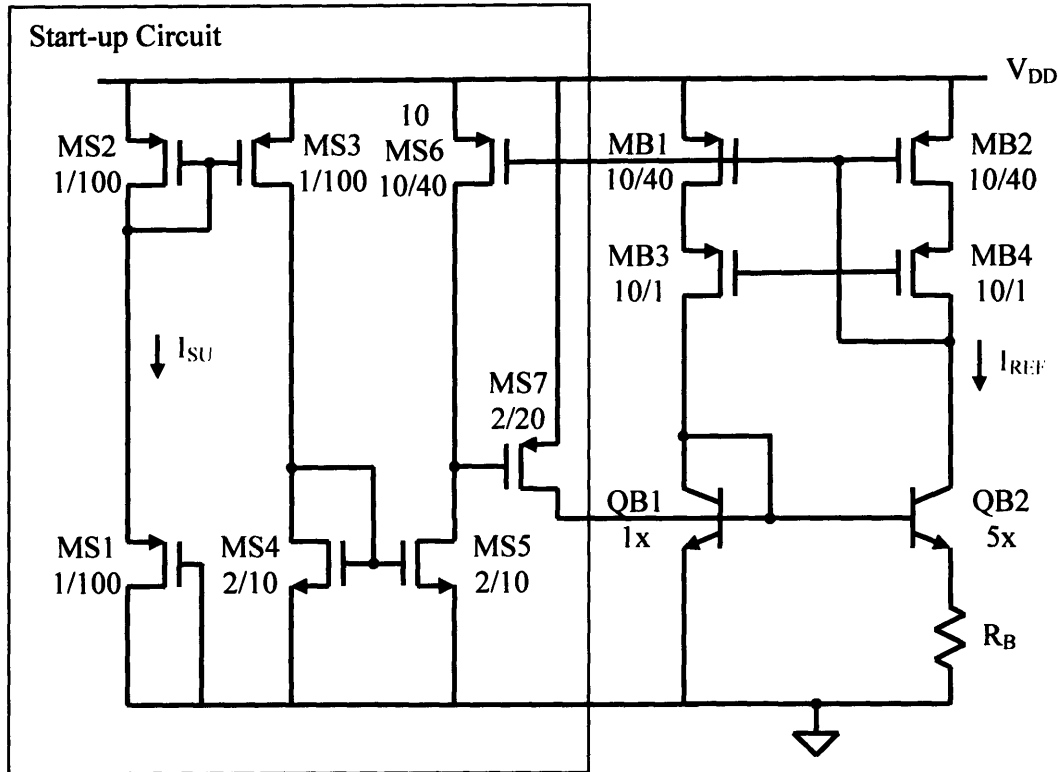

Figure 4-2: Bias Core with Start-up Circuit

The bias core has two stable points: one with $I_{C1} = I_{C2} = 0$, the other with $I_{C1} = I_{C2} = I_{REF}$. Without the start-up circuit, V_B of transistors QB1 and QB2 could be at GND, and thus not generating the reference current. For the bias core to generate a reference current, the base voltage of QB1 and QB2 must be initially pulled up from the ground by a start-up circuit. A compact start-up circuit used in this op amp is shown in Figure 4-2 [25]. MS1 and MS2 are sized to be narrow and long to minimize the start-up current, I_{SU} .

The first two devices in the start-up circuit becoming active upon the power up are MS1 and MS2. The supply voltage across their gate-source voltages forces them to turn on, and thereby, MS1 and MS2 start to conduct start-up current I_{SU} . The start-up current is then mirrored to MS3-MS4, and MS5 respectively. At this moment, MS5 tries to sink current from MS6, but MS6 cannot source any current because the bias core has not been turned on. Therefore, the gate of MS7 is pulled to ground, causing MS7 to pull the bases of QB1 and QB2 up from ground and the bias core is in operation. Now, MS6

can source enough current to MS5 and turn MS7 off by pulling its gate up. Note that MS6 is sized to be 10 times as wide as MB1 and MB2 so that MS7 can be easily turned off as soon as the bias core starts to supply I_{REF} . The final current in MS6 is limited by MS5.

The start-up current, I_{SU} , can be estimated by the following. Upon the power up, MS1 and MS2 see the supply voltage across their gate-source voltages according to the relation.

$$V_{SGMS1} + V_{SGMS2} = V_{DD} \quad (4-10)$$

To simplify the calculation, the body effect on V_{TP} increase of MS1 is ignored, and the following approximation is made.

$$V_{SGMS1} \approx V_{SGMS2} \quad (4-11)$$

And thus,

$$V_{SGMS2} \approx \frac{V_{DD}}{2} \quad (4-12)$$

MS2 is in saturation because it is diode-connected. The start-up current can be approximated by

$$I_{SU} = -I_D \approx \frac{\mu_p C_{ox}}{2} \left(\frac{W}{L} \right) (V_{SGMS2} + V_{TPMS2})^2 \quad (4-13)$$

$$I_{SU} = -I_D \approx \frac{\mu_p C_{ox}}{2} \left(\frac{W}{L} \right) (V_{SGMS2} + V_{TP0})^2 \quad (4-14)$$

$$\boxed{I_{SU} = -I_D \approx \frac{\mu_p C_{ox}}{2} \left(\frac{W}{L} \right) \left(\frac{V_{DD}}{2} + V_{TP0} \right)^2} \quad (4-15)$$

This approximation is an overestimate of I_{SU} because in reality $V_{SGMS1} > V_{SGMS2}$ due to the body effect.

4.3 Reference Voltages Bias Circuit

Besides the reference current generated by the bias cell, the op amp needs two reference voltages: one is the reference voltage for PMOS cascode transistors, the other is that for NMOS cascode transistors.

The circuit in Figure 4-3 shows how to set up the two reference voltages.

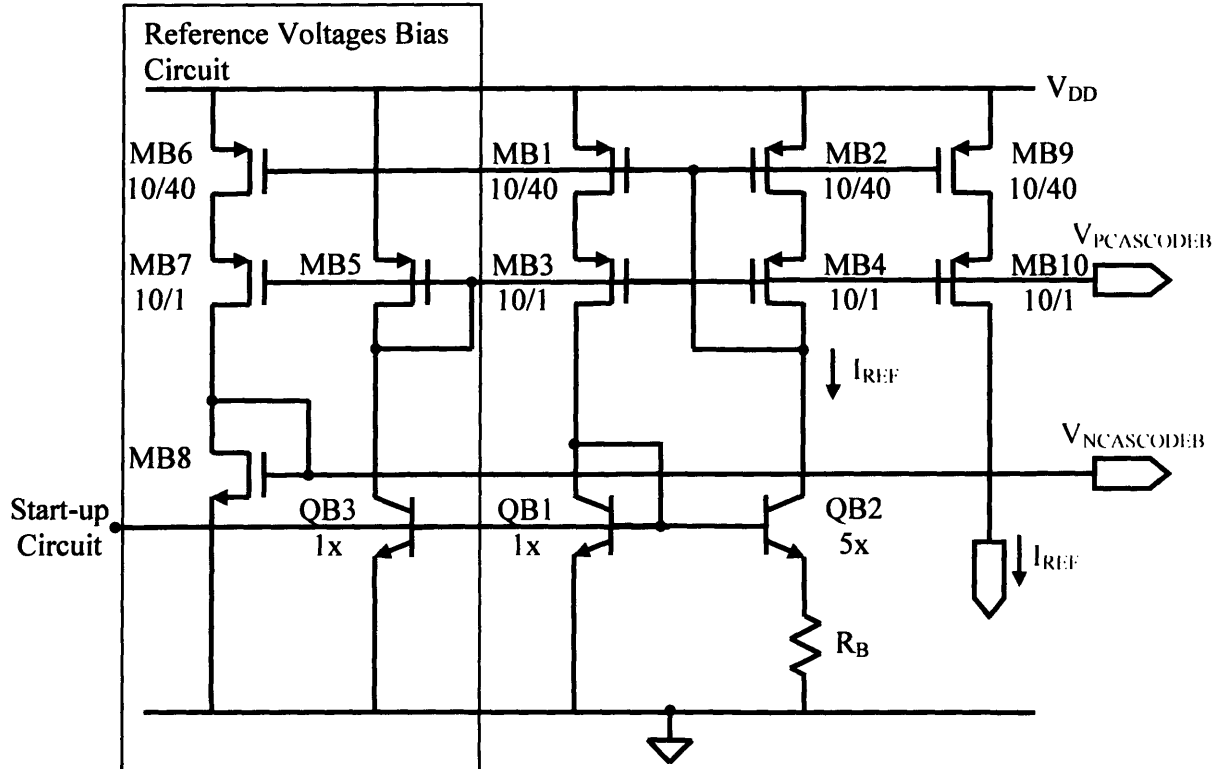

Figure 4-3: Reference Voltages Set Up in Bias Cell

MB5 sets up the reference voltage for PMOS cascode transistors, and MB8 sets up the reference voltage for NMOS cascode transistors. The voltage at the gate of MB8, $V_{NCASCODEB}$, can be determined as follows.

Transistor MB6 mirrors the reference current, I_{REF} , to MB8. Since MB8 is diode-connected, it operates in the saturation region and

$$V_{NCASCODEB} = V_{GSMB8} = \sqrt{\frac{2I_D}{\mu_n C_{ox} \left(\frac{W}{L}\right)}} + V_{TN0}$$

(4-16)

Similarly,

$$V_{PCASCODEB} = V_{DD} - V_{SGMB5} = V_{DD} - \left(\sqrt{\frac{2I_D}{\mu_p C_{ox} \left(\frac{W}{L}\right)}} - V_{TP0} \right) \quad (4-17)$$

In the design, $V_{NCASCODEB}$ and $V_{PCASCODEB}$ are set up such that all the inner transistors of current mirrors (e.g. transistors MB1 and MB2 of current mirror MB1-MB2-MB3-MB4, for example) operate in the saturation region by having $V_{DS} > 0.4V$. Together with I_{REF} , $V_{PCASCODEB}$, and $V_{NCASCODEB}$, are passed on to the op amp.

In an IC, especially large ones, the supply voltage line and common ground line vary slightly from one corner to another. Therefore, reference current I_{REF} is fed to the op amp as a current instead of the gate voltage of MB2 to ensure the accuracy of bias currents in the op amp. In contrast, the cascode transistors' voltages, $V_{PCASCODEB}$ and $V_{NCASCODEB}$, are supplied to the op amp as voltages because their deviation from the intended value has little effect on the biasing in the op amp.

The complete bias cell is shown in Figure 4-4. The value of reference current varies as little as 3.1nA when changing from the supply voltage of 2.5V to 6.0V. Figure 4-5 show the values of I_{REF} , I_{SU} , $V_{NCASCODEB}$, and $V_{PCASCODEB}$ as a function of supply voltage V_{DD} .

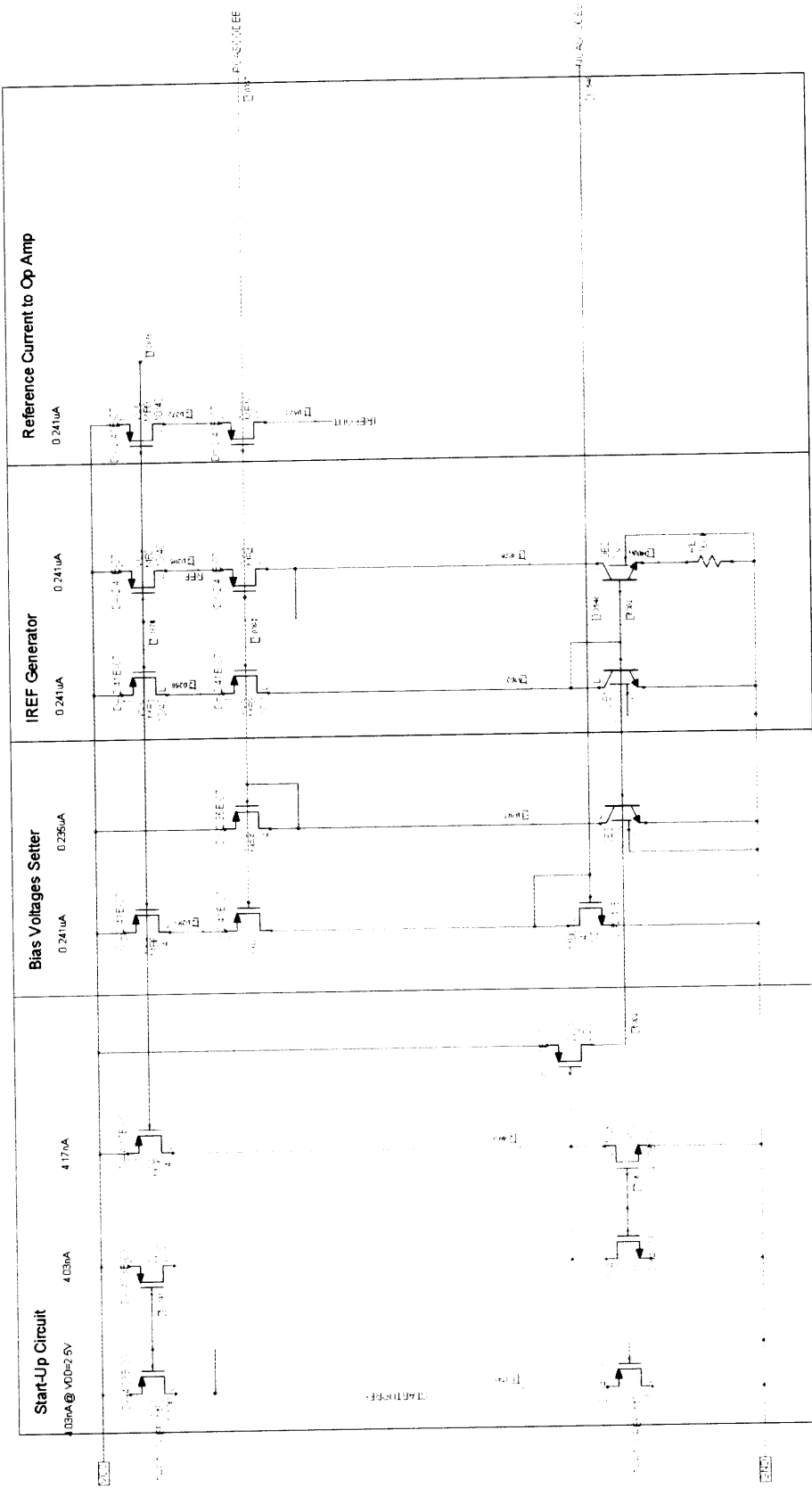

Figure 4-4: Schematic of Bias Cell

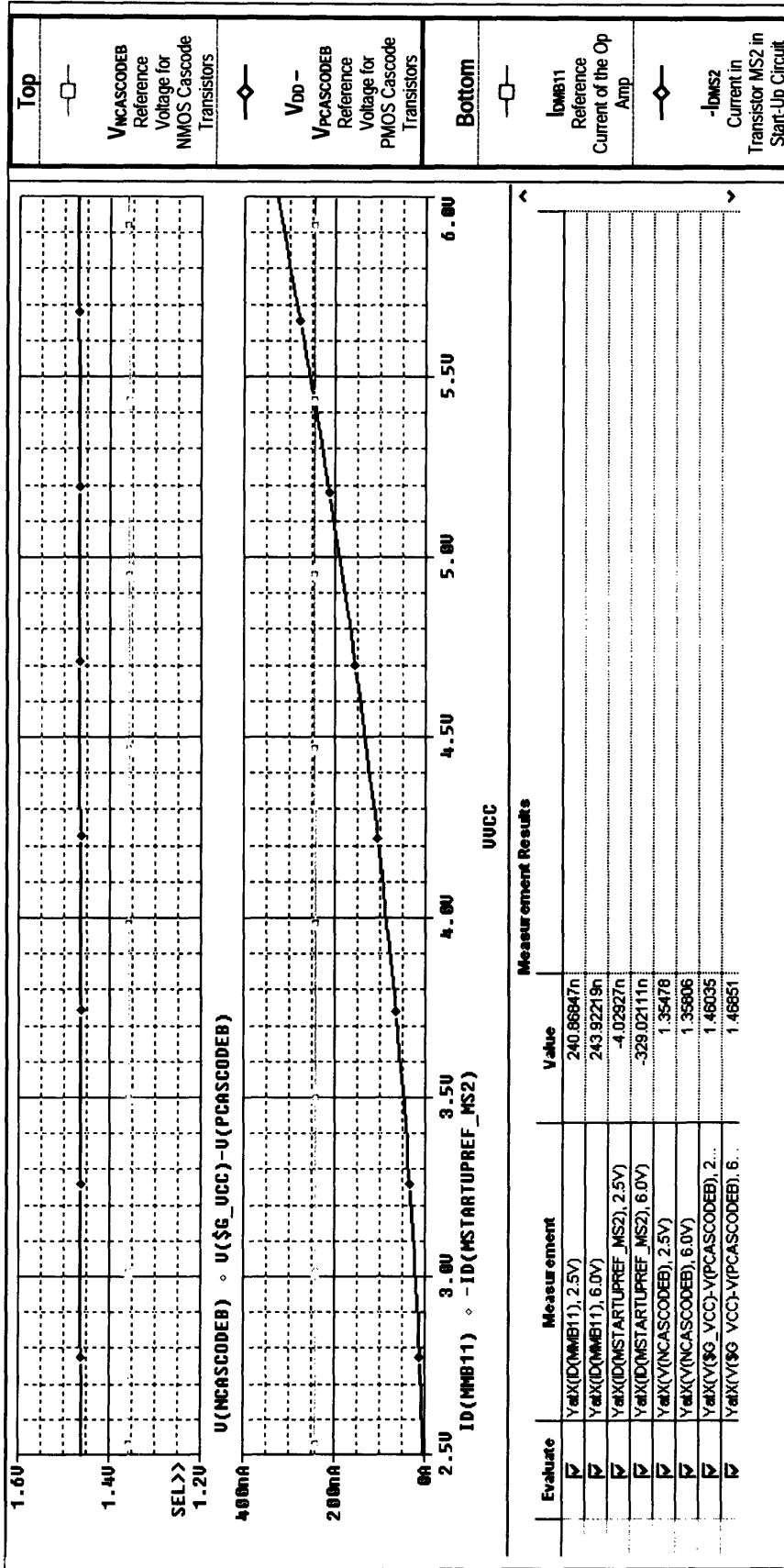

Figure 4-5: I_{REF} , I_{SU} , $V_{NCASCODEB}$, and $V_{PCASCODEB}$ vs. V_{DD}

Chapter 5 Frequency Compensation

The previous chapters have explained the design process of the op amp and the bias cell. The remaining part to complete the micropower op amp design is the frequency compensation. This chapter briefly discusses two frequency compensation schemes. The most popular compensation scheme, simple Miller compensation, is considered first. Next, cascode compensation is explored as a potential scheme in extending the gain bandwidth product but with a defect of causing peaking in the frequency response. The combination of the previous two compensation schemes is then presented as the solution which offers moderate improvement in gain bandwidth and eliminates the peaking problem in the frequency response of the op amp.

5.1 Proposed Micropower Op Amp with Simple Miller Compensation (SMC)

The most common scheme to compensate two-stage op amps is Simple Miller Compensation (SMC) [28], [29]. The implementation is achieved by feeding the output signal back to the input of the output pair transistors through capacitors C_{C1} and C_{C2} as shown in Figure 5-1. A disadvantage of SMC is that the right half plane zero severely compromises the phase margin. This problem can be alleviated by inserting nulling resistors R_{C1} and R_{C2} in series with the existing compensation capacitors to reduce the feedforward signal. However, there is limitation on the values of the nulling resistors. As their values increase, the left half plane zero moves toward lower frequencies. Although this movement of the left half plane zero helps increase the phase margin of the op amp, it also reduces the gain margin at the same time. In the proposed op amp with simple Miller compensation, the gain margin is designed to be at least 10dB and this requirement is the limit on the nulling resistors size. The complete micropower op amp with Simple Miller Compensation (SMC) is illustrated in

Figure 5-2. Figure 5-3 and Figure 5-4 show its frequency response and transient response respectively. With supply current of $20\mu\text{A}$, the proposed op amp with SMC has a unity gain frequency of 360kHz with 61.5° phase margin at 100pF load.

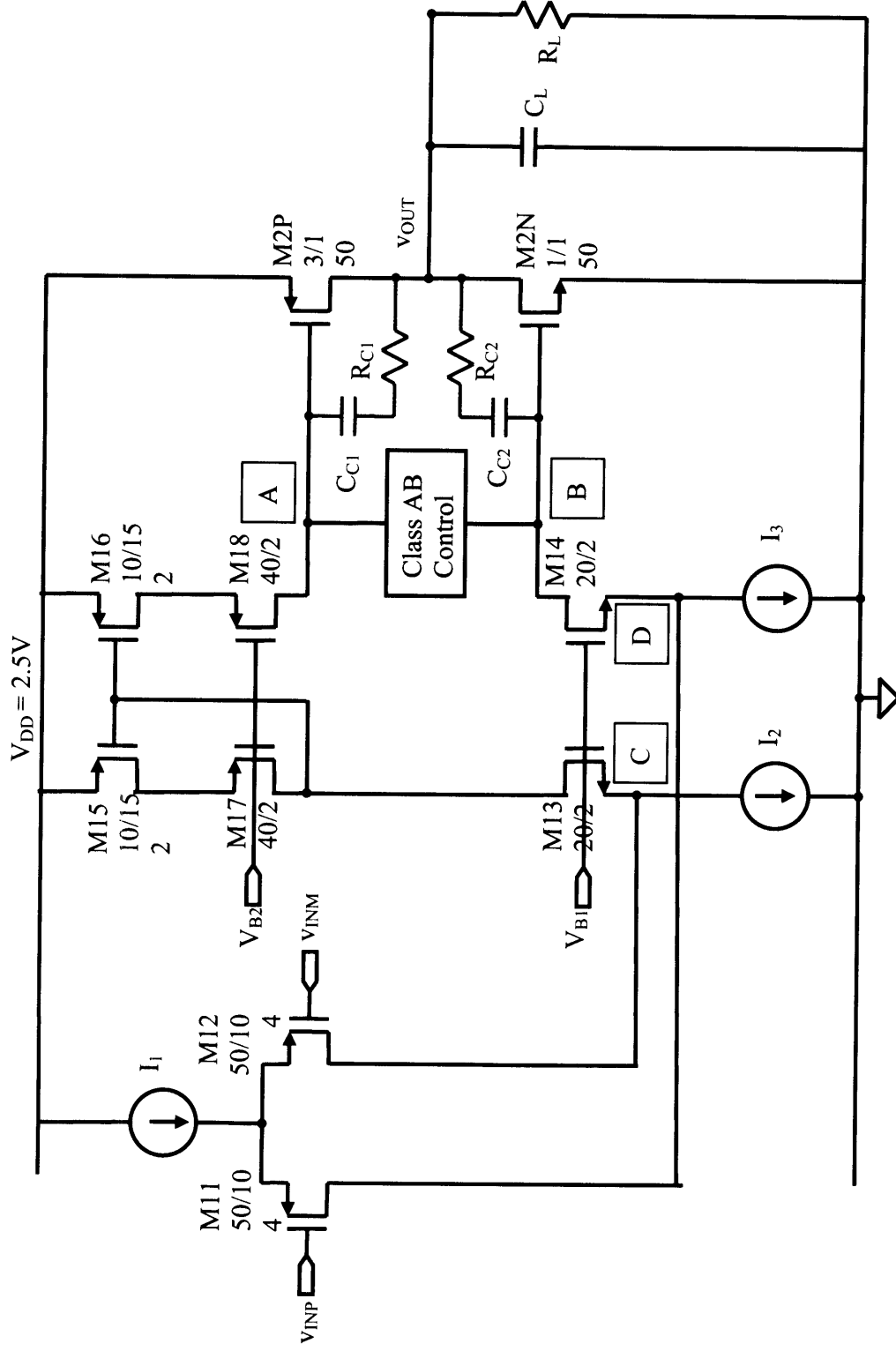

Figure 5-1: Simplified Schematic of Proposed Micropower Op Amp with Simple Miller Compensation (SMC)

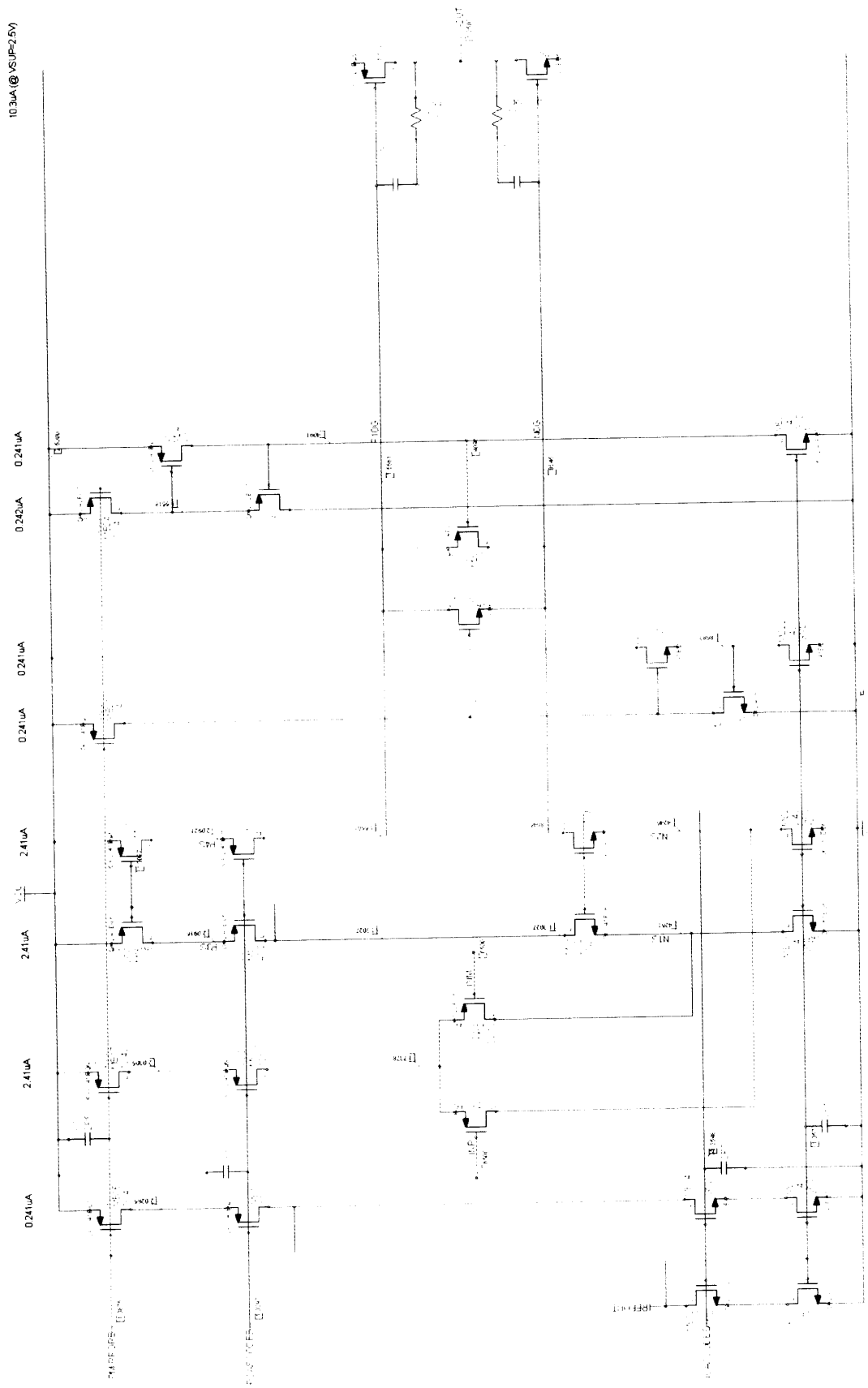

Figure 5-2: Schematic of Proposed Micropower Op Amp with Simple Miller Compensation (SMC)

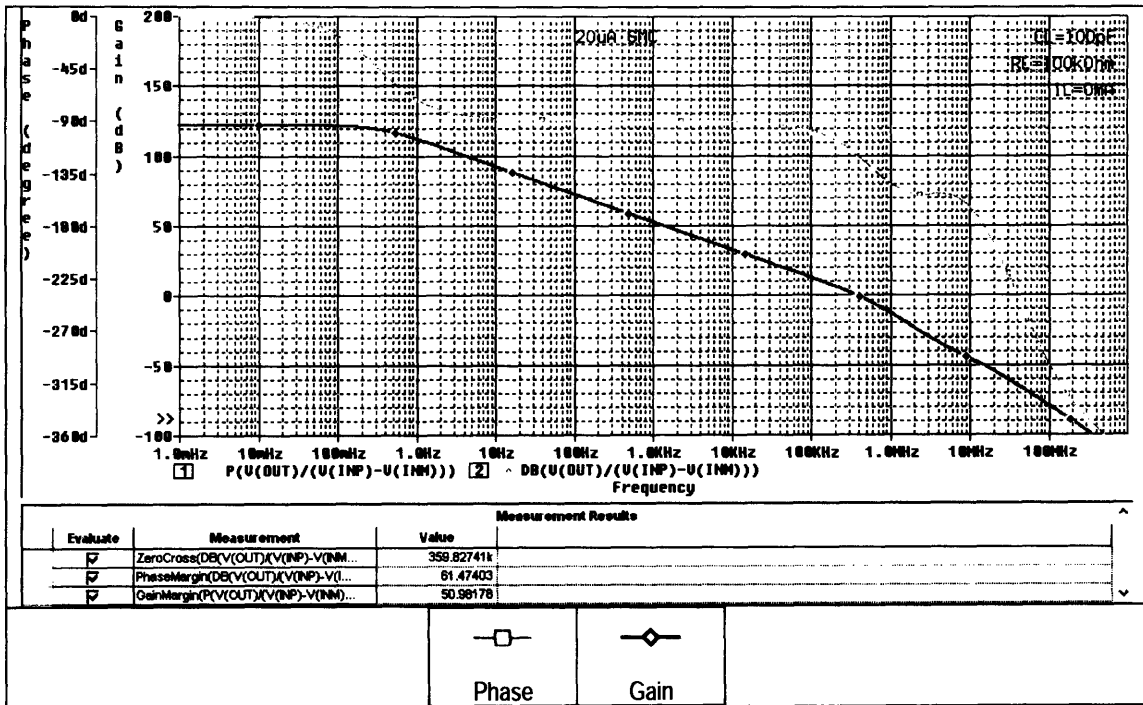

Figure 5-3: Frequency Response with $C_L=100\text{pF}$ and $R_L=100\text{k}\Omega$ of Proposed Micropower Op Amp with Simple Miller Compensation (SMC)

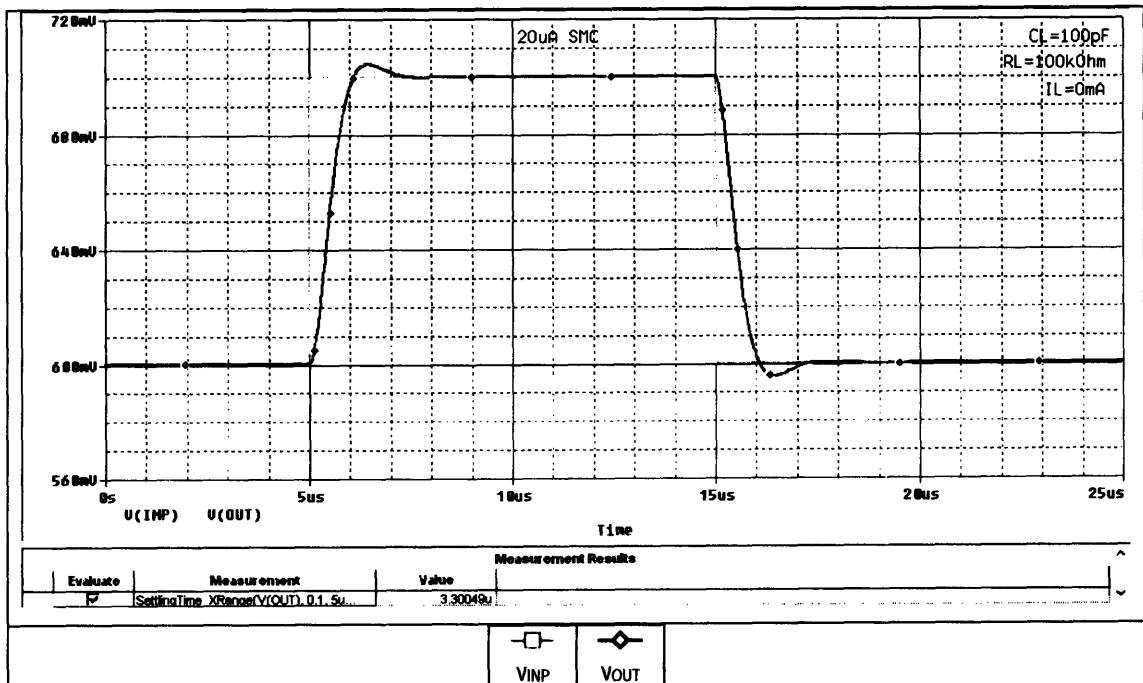

Figure 5-4: Small-Signal Transient Response with $C_L=100\text{pF}$ and $R_L=100\text{k}\Omega$ of Proposed Micropower Op Amp with Simple Miller Compensation (SMC)

5.2 Cascode Compensation

The cascode compensation eliminates the feedforward signal by putting a current buffer in the compensation path as shown in Figure 5-5 [30]. This technique was first presented by Ahuja in [30]. It was also analyzed for Class A folded-cascode op amps by Ribner and Copeland in [31], and for fully differential op amps by Hurst et al. in [32].

In the proposed micropower op amp, two current buffers already exist in the design. One is the cascode transistor pair of the input pair. The other is the cascode transistor pair in the wide-swing current mirror. Therefore, there is no need to establish separate current buffers, and the compensation capacitors C_{C3} and C_{C4} can be directly connected to the embedded cascode transistors at node E and D respectively as depicted in Figure 5-6. The results show a significant improvement in the speed. The unity gain frequency extends to 991kHz as shown in Figure 5-7 when the output stage is at rest with the same supply current and loading condition. However, when the transconductance of the output stage transistors changes, there is peaking in the frequency response as shown in Figure 5-8. This defect in the frequency response greatly reduces the gain margin and causes oscillatory behavior in the small-signal transient response such as the one in Figure 5-9. In [33] and [34], Langen, Hogervorst, and Huijsing describe this problem of using only cascode compensation in Class AB op amps and suggest the need of keeping simple Miller compensation capacitors C_{C1} and C_{C2} to prevent the peaking.

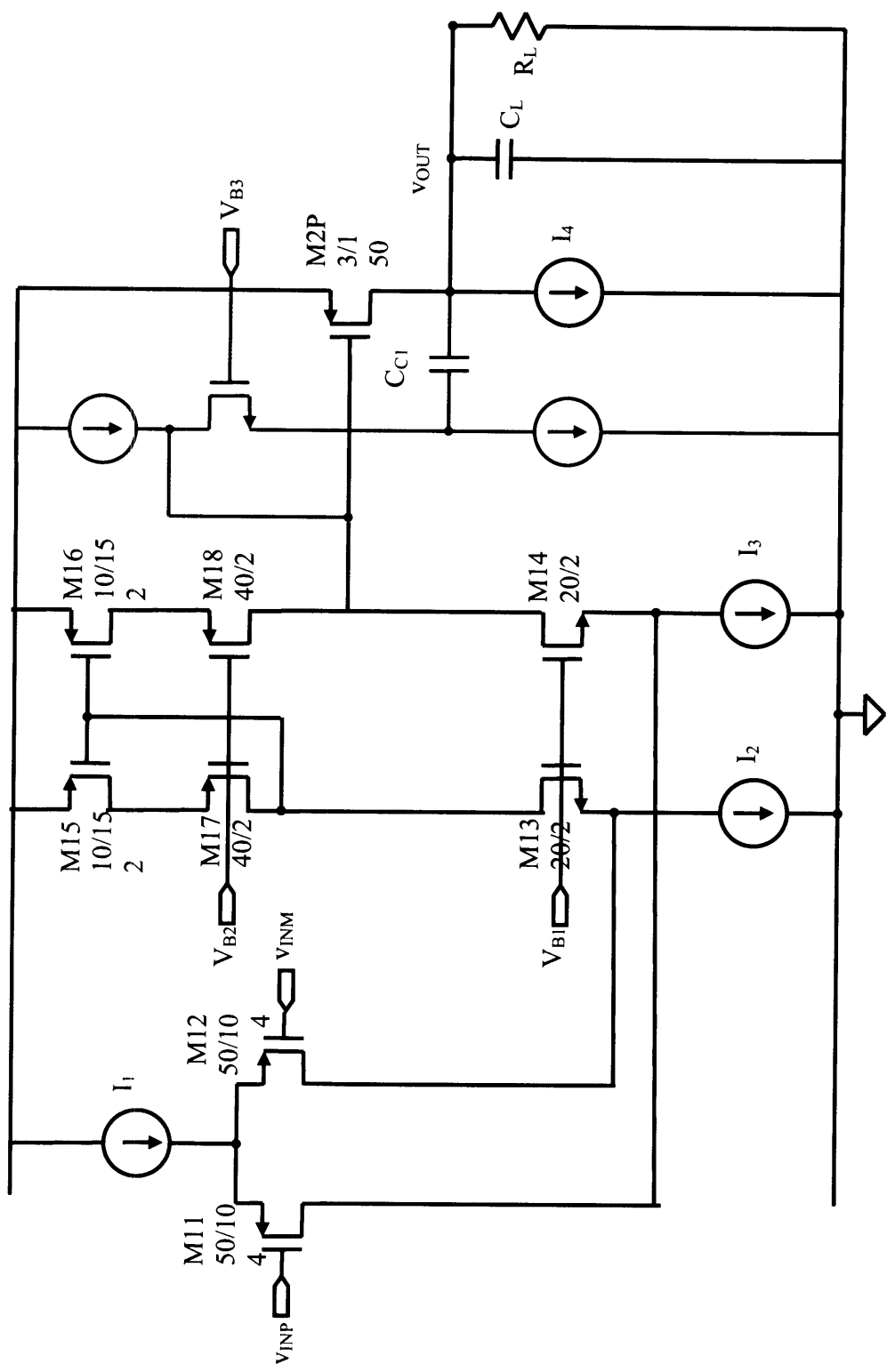

Figure 5-5: Class A Op Amp with Cascode Compensation (Adapted from [30])

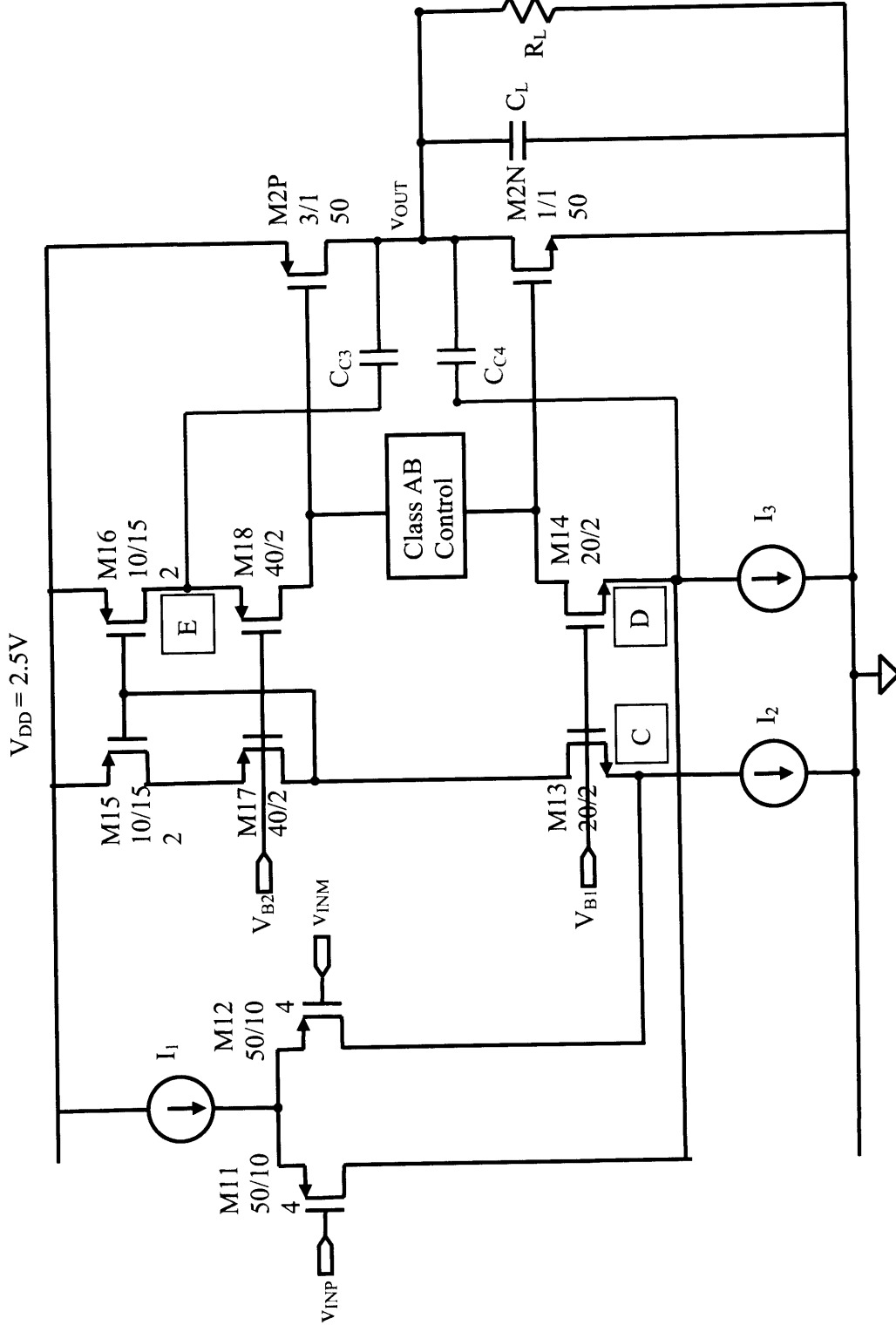

Figure 5-6: Simplified Schematic of Proposed Micropower Op Amp with Embedded Cascode Compensation (ECC) Only

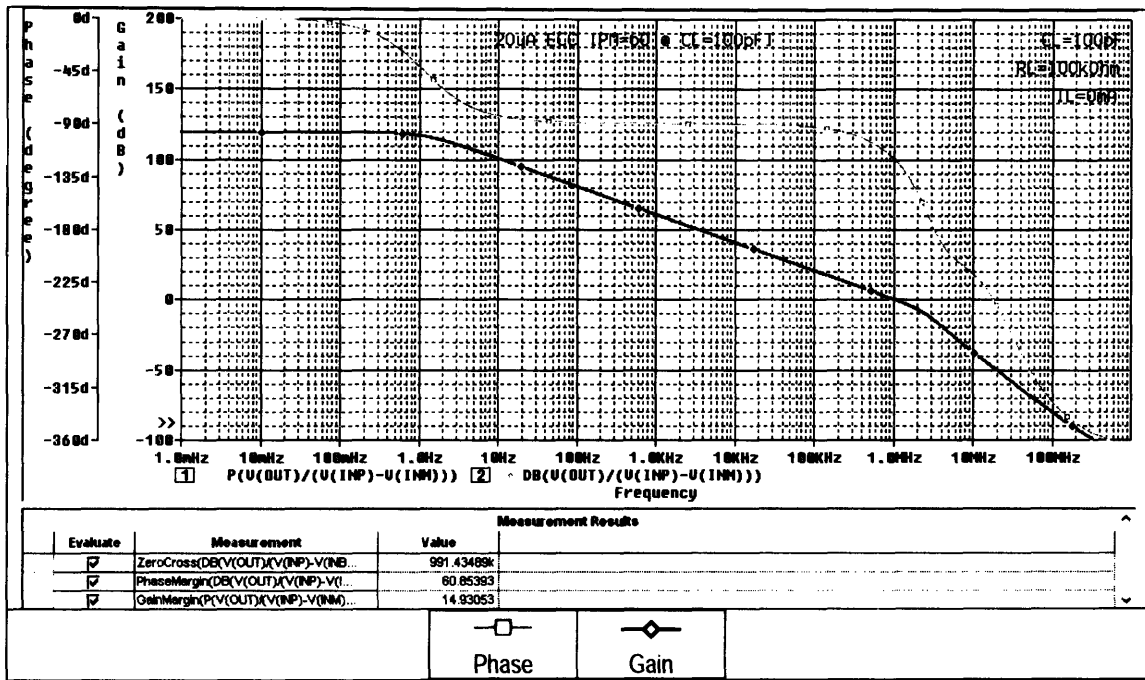

Figure 5-7: Frequency Response with $C_L=100\text{pF}$ and $R_L=100\text{k}\Omega$ of Proposed Micropower Op Amp with Embedded Cascode Compensation (ECC) Only

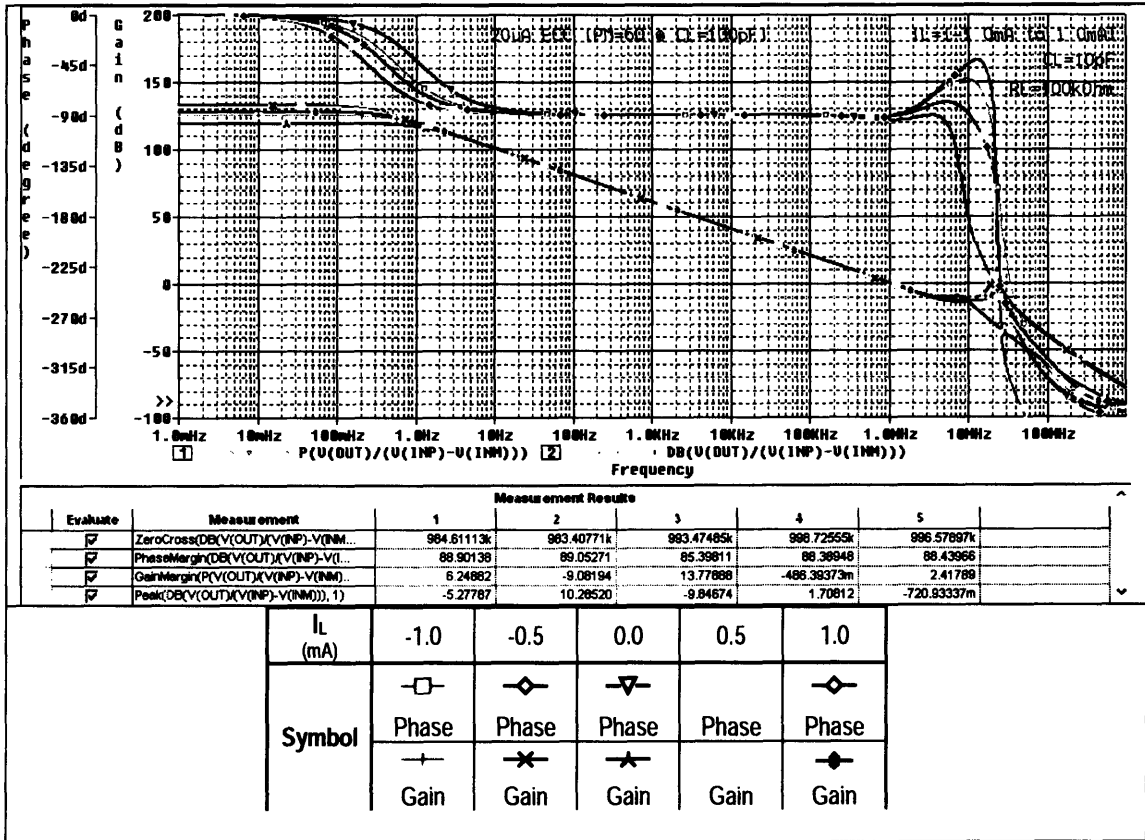

Figure 5-8: Frequency Response with $C_L=10\text{pF}$ and $R_L=100\text{k}\Omega$ @ $I_L=-1.0, -0.5, 0.0, 0.5, 1.0\text{mA}$ of Proposed Micropower Op Amp with Embedded Cascode Compensation (ECC) Only

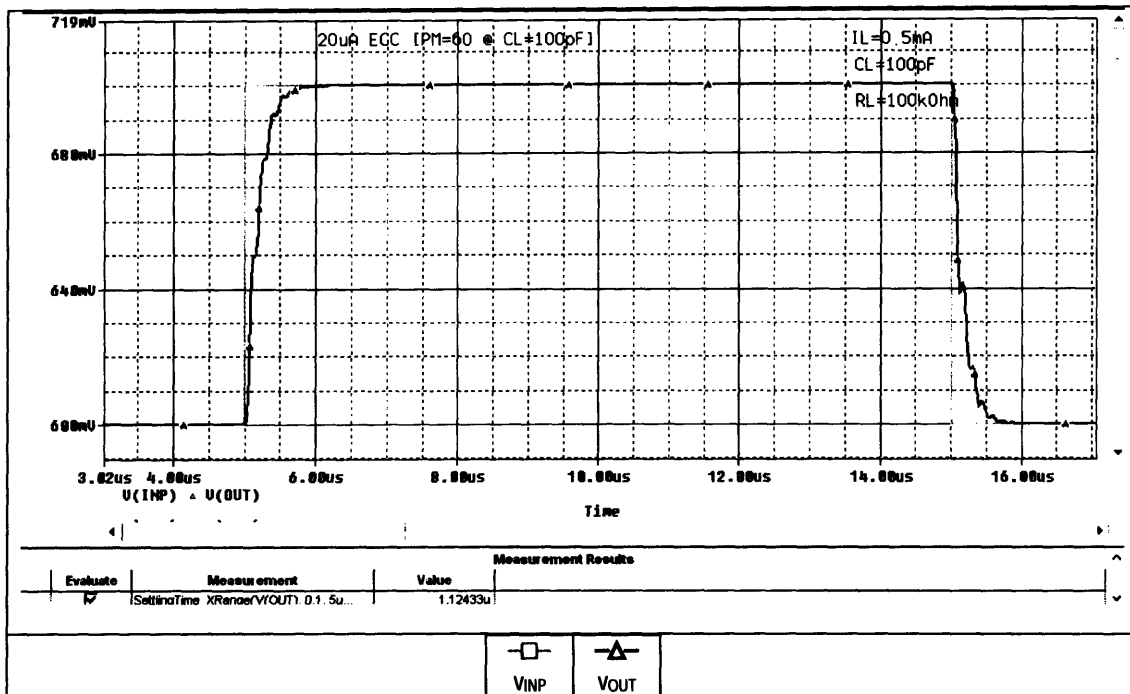

Figure 5-9: Small-Signal Transient Response with $C_L=100\text{pF}$, $R_L=100\text{k}\Omega$, and $I_L=0.5\text{mA}$ of Proposed Micropower Op Amp with Embedded Cascode Compensation (ECC) Only

5.3 Proposed Micropower Op Amp with Hybrid Asymmetric Embedded Cascode Compensation (HAECC)

In order to exploit the benefit of the cascode compensation, the proposed op amp employs the hybrid of the simple Miller compensation and the cascode compensation [33], [34]. The hybrid compensation maintains the simple Miller compensation path to tame the frequency response when the current in the output stage change as shown in Figure 5-10. The detailed schematic of the proposed op amp with this compensation scheme is in Figure 5-11. The simulation results show an improved unity gain frequency of 589kHz with the same supply current of $20\mu\text{A}$ and load condition of 100pF as depicted in Figure 5-12. The op amp now exhibits neither the peaking behavior in its frequency response nor the oscillatory transient response when the current in the output pair change as shown in Figure 5-13 and Figure 5-14 respectively

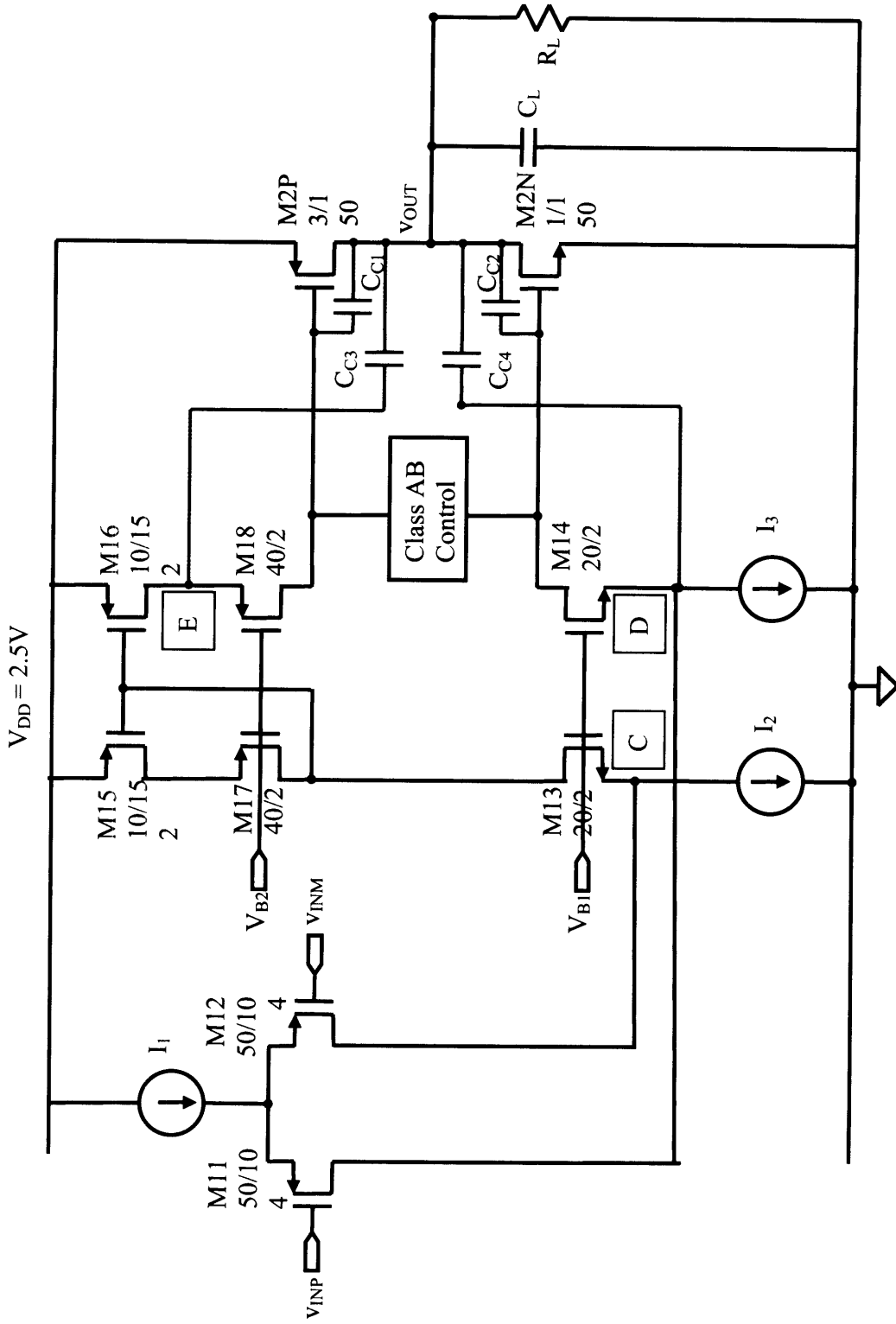

Figure 5-10: Simplified Schematic of Proposed Op Amp with Hybrid Asymmetric Embedded Cascode Compensation (HAECC)

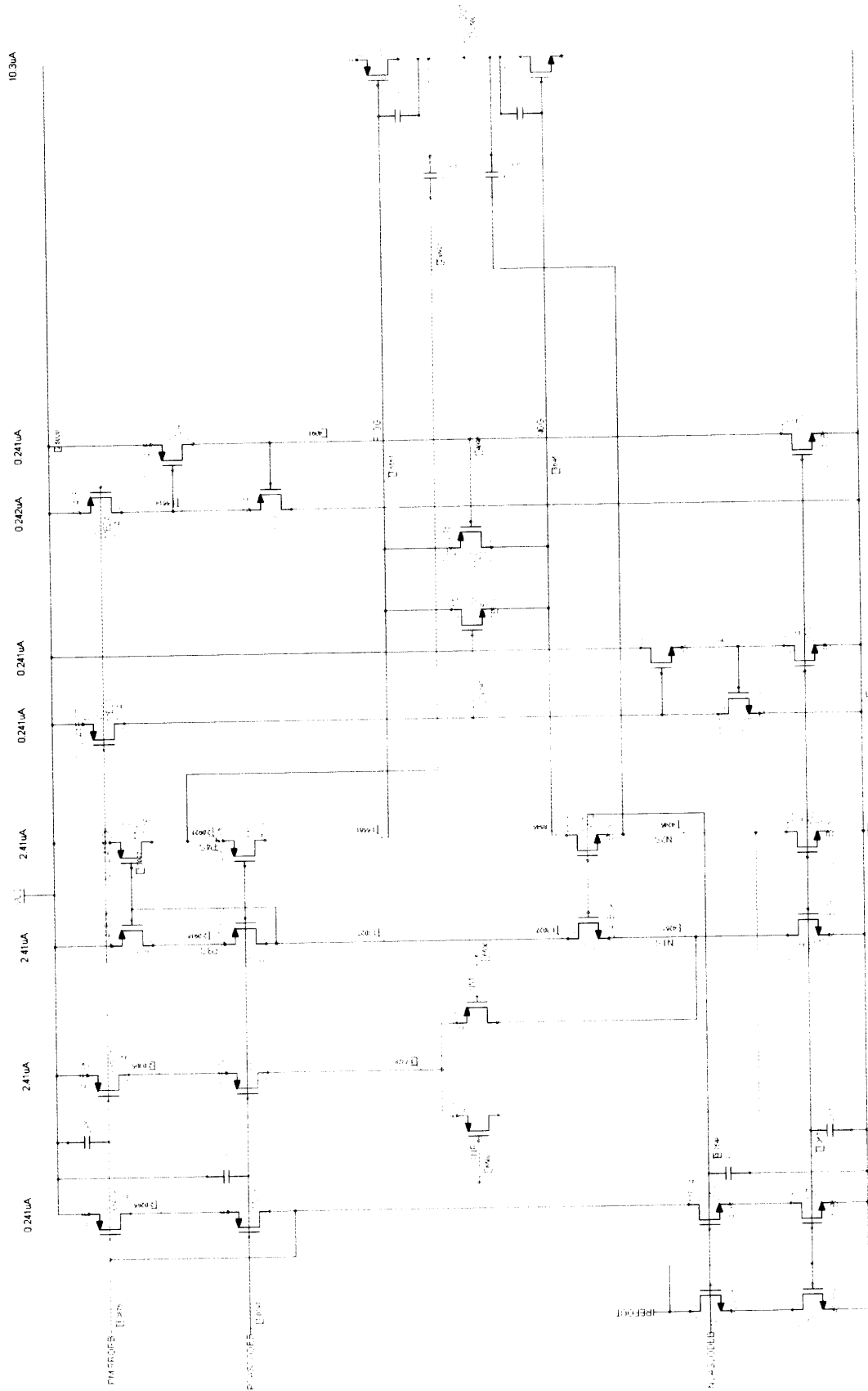

Figure 5-11: Schematic of Proposed Micropower Op Amp with Hybrid Asymmetric Embedded Cascade Compensation (HA ECC)

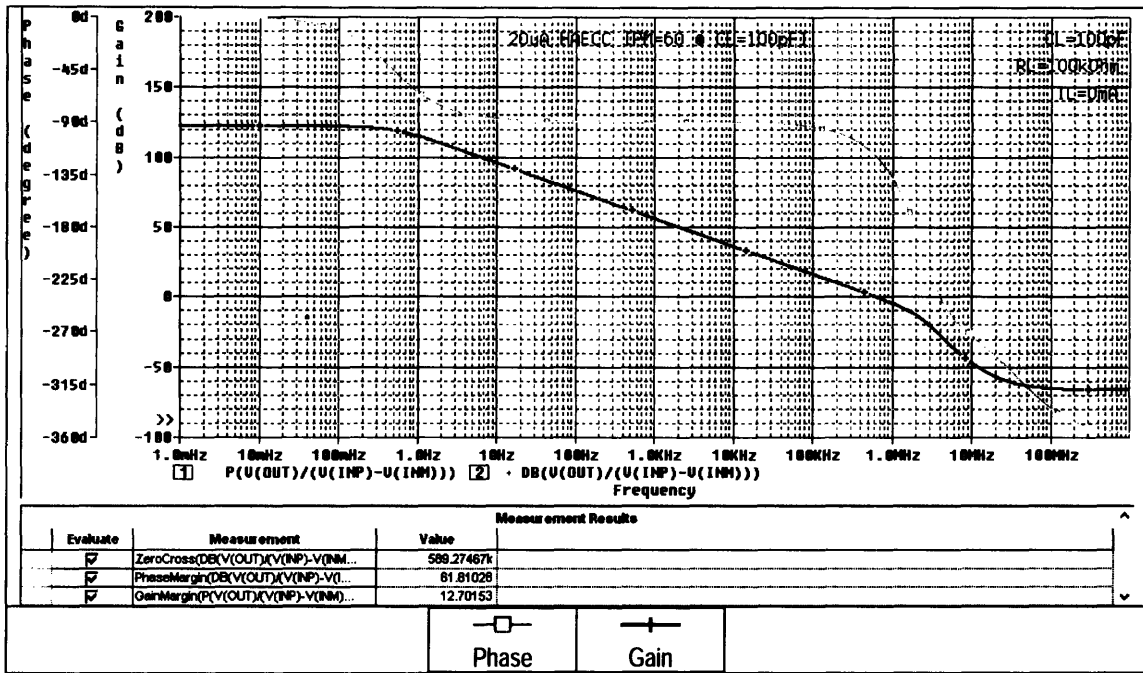

Figure 5-12: Frequency Response with $C_L=100\text{pF}$ and $R_L=100\text{k}\Omega$ of Proposed Micropower Op Amp with Hybrid Asymmetric Embedded Cascode Compensation (HAECC)

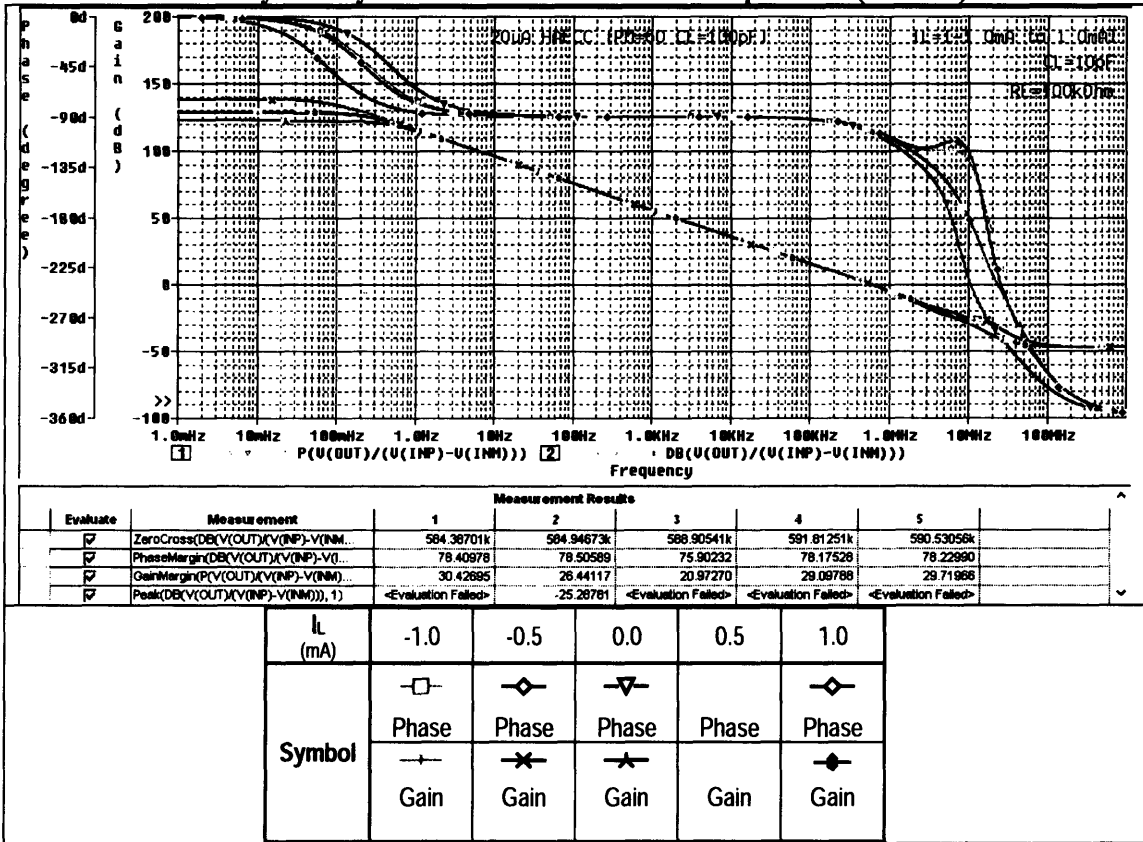

Figure 5-13: Frequency Response with $C_L=10\text{pF}$ and $R_L=100\text{k}\Omega$ @ $I_L=-1.0, -0.5, 0.0, 0.5, 1.0\text{mA}$ of Proposed Micropower Op Amp with Hybrid Asymmetric Embedded Cascode Compensation (HAECC)

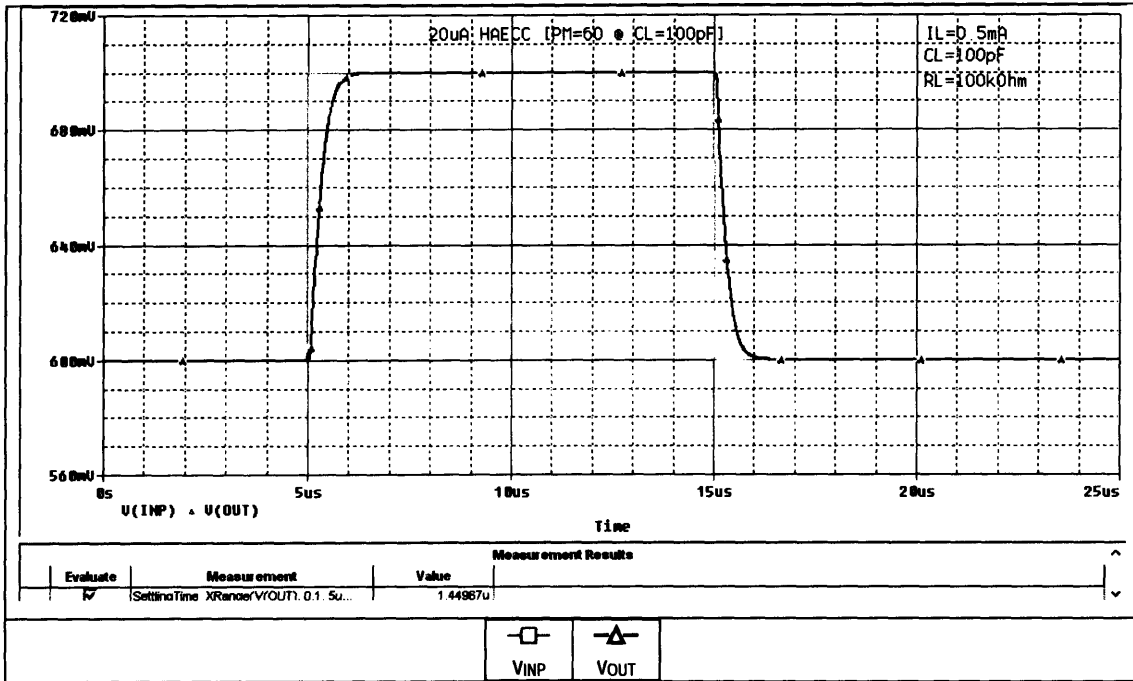

Figure 5-14: Small-Signal Transient Response with $C_L=100\text{pF}$, $R_L=100\text{k}\Omega$, and $I_L=0.5\text{mA}$ of Proposed Micropower Op Amp with Hybrid Asymmetric Embedded Cascode Compensation (HAECC)

Chapter 6 Final Results and Conclusion

Final Results

Two micropower op amp designs have proved to satisfy the project specifications set forth in Chapter 1. They essentially have the same architecture, but employ different frequency compensation schemes. The first one (Figure A-1 in Appendix A) uses Simple Miller Compensation (SMC). The other one (Figure D-1 in Appendix D) is compensated by a combination of simple Miller compensation and cascode compensation, or called Hybrid Asymmetric Embedded Cascode Compensation (HAECC) in this thesis. The detailed simulation results of all op amp designs are in the appendices. Table 6-1 summarizes the characteristics of the proposed micropower op amp with simple Miller Compensation (SMC). It has a unity gain frequency of 360kHz with 61.5° phase margin when loaded with 100pF. The proposed micropower op amp with Hybrid Asymmetric Embedded Cascode Compensation (HAECC) has a higher unity gain frequency of 589kHz at the same loading and power dissipation condition. Table 6-2 includes the detailed simulated characteristics of the design with HAECC.

Table 6-1: Characteristics of 20 μ A Micropower Op Amp with Simple Miller Compensation (SMC)

Simulation results are at 25°C. $V_{DD} = 2.5V$ and $V_{SS} = 0V$.					
Primary Characteristics					
Symbol	Parameter	Condition	Value		Unit
			Specified	Simulated	
GBW ⁵	Gain Bandwidth Product	$C_L = 100pF$ $R_L = 100k\Omega$	> 0.3	0.360 ($\Phi_M = 61.5^\circ$)	MHz
A_{VOL}	Large-Signal Voltage Gain (DC Open-Loop Gain)	$C_L = 100pF$ $R_L = 100k\Omega$	> 100	122	dB
I_S	Supply Current	No Load	< 21	19.95	μA
V_{INCM}^6	Input Common-Mode Range	-	> $V_{DD} - 1.25V$	1.3	V

⁵ Gain bandwidth product per supply current $GBW/I_S = 18MHz/mA$ @ $C_L = 100pF$.

⁶ Verified by CMRR simulation in Figure A-4.

			and must include negative supply voltage	and includes negative supply voltage	
V_{OS}^7	(Untrimmed) Input Offset Voltage		$V_{INCM} = 0.65V$	< 5	4.18 mV
V_{OUT}	V_{OUTH}	High Output Voltage	$I_{SOURCE} = 1.0mA$	$> V_{DD} - 0.3V$	2.34 V
	V_{OUTL}	Low Output Voltage	$I_{SINK} = 1.0mA$	$< V_{SS} + 0.3V$	0.19 V
I_{SOURCE}^8	Output Source Current		$C_L = 100pF$ $R_L = 100k\Omega$	> 1.0	1.55 mA
I_{SINK}	Output Sink Current		$C_L = 100pF$ $R_L = 100k\Omega$	> 1.0	1.04 mA
Secondary Characteristics					
Symbol	Parameter	Condition	Value		Unit
			Specified	Simulated	
SR	Positive Going Slew Rate	$A_V = 1V/V, 1V$ Step	> 0.15	0.223	V/ μ s
SR-	Negative Going Slew Rate	$A_V = 1V/V, 1V$ Step	< -0.15	-0.236	V/ μ s
CMRR	Common Mode Rejection Ratio	@ DC	> 60	144	dB
PSRR+	Positive Power Supply Rejection Ratio	@ DC	> 60	84.5	dB
PSRR-	Negative Power Supply Rejection Ratio	@ DC	> 60	99.4	dB
t_s	0.1% Settling Time	$A_V = 1V/V, 1V$ Step	< 10	5.29	μ s

Table 6-2: Characteristics of 20 μ A Micropower Op Amp with Hybrid Asymmetric Embedded Cascode Compensation (HAECC)

Simulation results are at 25°C. $V_{DD} = 2.5V$ and $V_{SS} = 0V$.					
Primary Characteristics					
Symbol	Parameter	Condition	Value		Unit
			Specified	Simulated	
GBW^9	Gain Bandwidth Product	$C_L = 100pF$ $R_L = 100k\Omega$	> 0.3	0.589 ($\Phi_M = 61.8^\circ$)	MHz

⁷ Conservative estimate from calculation.

⁸ Maximum output source current is measured when the other transistor in the output pair starts to turn off, i.e. its current goes down to as low as 1 μ A.

⁹ Gain bandwidth product per supply current $GBW/I_S = 29.5MHz/mA$ @ $C_L = 100pF$.

A_{VOL}	Large-Signal Voltage Gain (DC Open-Loop Gain)		$C_L = 100\text{pF}$ $R_L = 100\text{k}\Omega$	> 100	122	dB
I_S	Supply Current		No Load	< 21	19.95	μA
V_{INCM}^{10}	Input Common-Mode Range		-	$> V_{DD} - 1.25\text{V}$ and must include negative supply voltage	1.3 and includes negative supply voltage	V
V_{OS}^{11}	(Untrimmed) Input Offset Voltage		$V_{INCM} = 0.65\text{V}$	< 5	4.17	mV
V_{OUT}	V_{OUTH}	High Output Voltage	$I_{SOURCE} = 1.0\text{mA}$	$> V_{DD} - 0.3\text{V}$	2.34	V
	V_{OUTL}	Low Output Voltage	$I_{SINK} = 1.0\text{mA}$	$< V_{SS} + 0.3\text{V}$	0.19	V
I_{SOURCE}^{12}	Output Source Current		$C_L = 100\text{pF}$ $R_L = 100\text{k}\Omega$	> 1.0	1.55	mA
I_{SINK}	Output Sink Current		$C_L = 100\text{pF}$ $R_L = 100\text{k}\Omega$	> 1.0	1.03	mA
Secondary Characteristics						
Symbol	Parameter	Condition	Value		Unit	
			Specified	Simulated		
SR+	Positive Going Slew Rate	$A_V = 1\text{V/V}, 1\text{V}$ Step	> 0.15	0.315	V/ μs	
SR-	Negative Going Slew Rate	$A_V = 1\text{V/V}, 1\text{V}$ Step	< -0.15	-0.342	V/ μs	
CMRR	Common Mode Rejection Ratio	@ DC	> 60	144	dB	
PSRR+	Positive Power Supply Rejection Ratio	@ DC	> 60	84.6	dB	
PSRR-	Negative Power Supply Rejection Ratio	@ DC	> 60	99.5	dB	
t_s	0.1% Settling Time	$A_V = 1\text{V/V}, 1\text{V}$ Step	< 10	3.70	Ms	

¹⁰ Verified by CMRR simulation in Figure D-4.

¹¹ Conservative estimate from calculation.

¹² Maximum output source current is measured when the other transistor in the output pair starts to turn off, i.e. its current goes down to as low as $1\mu\text{A}$.

Discussion

The two proposed micropower op amp designs have a higher unity gain frequency than the two commercial low-power op amp ICs previously mentioned, MAX9914 and MIC861, when compared at approximately the same supply current and loading condition. The design with HAECC offers a gain bandwidth product of 1.87MHz when compensated to have phase margin of 45° at 15pF load as shown in Figure 6-1. Table 6-3 summarizes the frequency domain performances of the proposed design and MAX9914.

In addition, when the proposed design is biased at 5μA, the one with HAECC compensation gives a gain bandwidth product of 375kHz with the phase margin of 45° at 50pF as depicted in Figure 6-2, which is higher than that of MIC861. Table 6-4 presents the overview of the comparison between the proposed designs and MIC861.

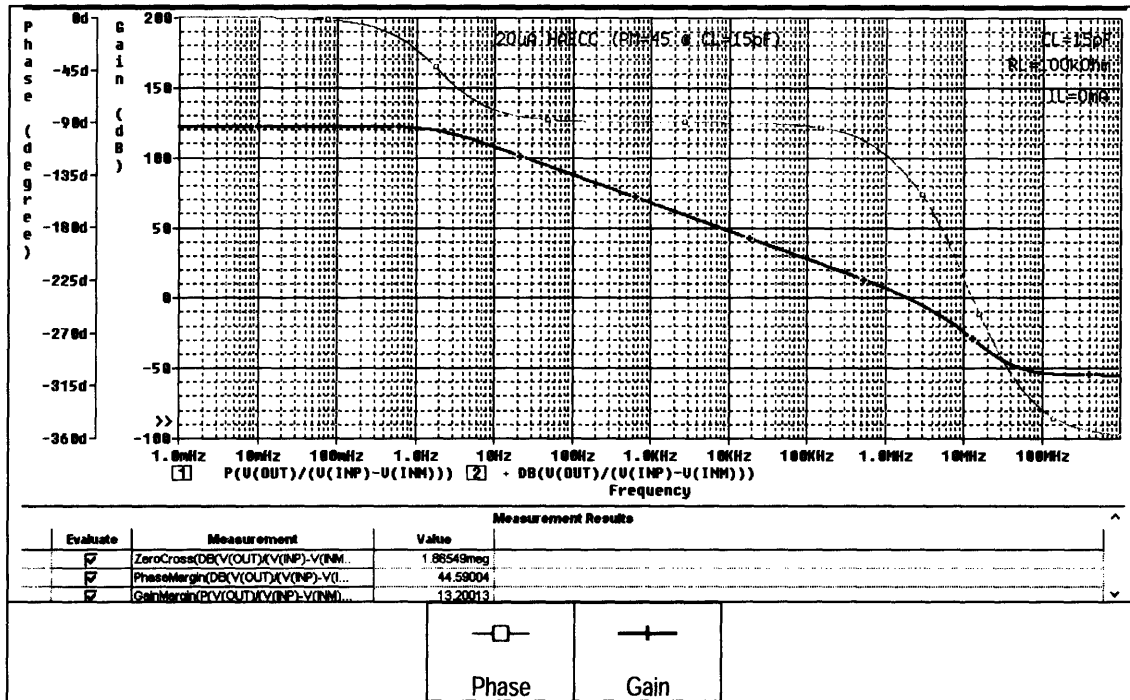

Figure 6-1: Frequency Response of 20μA Micropower Op Amp with HAECC Compensated Down to Have $\Phi_M = 45^\circ$ at 15pF Load to Compare with MAX9914

20 μ A Op Amp [$\Phi_M=45^\circ$ @ $C_L=15\text{pF}$, vs MAX9914]		Frequency Response			
		$C_L = 0\text{pF}, R_L = 100\text{k}\Omega$		$C_L = 15\text{pF}, R_L = 100\text{k}\Omega$	
		GBW (MHz)	Φ_M ($^\circ$)	GBW (MHz)	Φ_M ($^\circ$)
Simple Miller Compensation	SMC	1.79	72	1.65	47
Hybrid Explicit Cascode Compensation	HECC	1.63	68	1.56	46
Hybrid Asymmetric Embedded Cascode Compensation	HAECC	1.91	63	1.87	45
MAX9914[3]		-	-	1.0	45

Table 6-3: Comparison of Unity Gain Frequency between the Proposed 20 μ A Micropower Op Amps and MAX9914

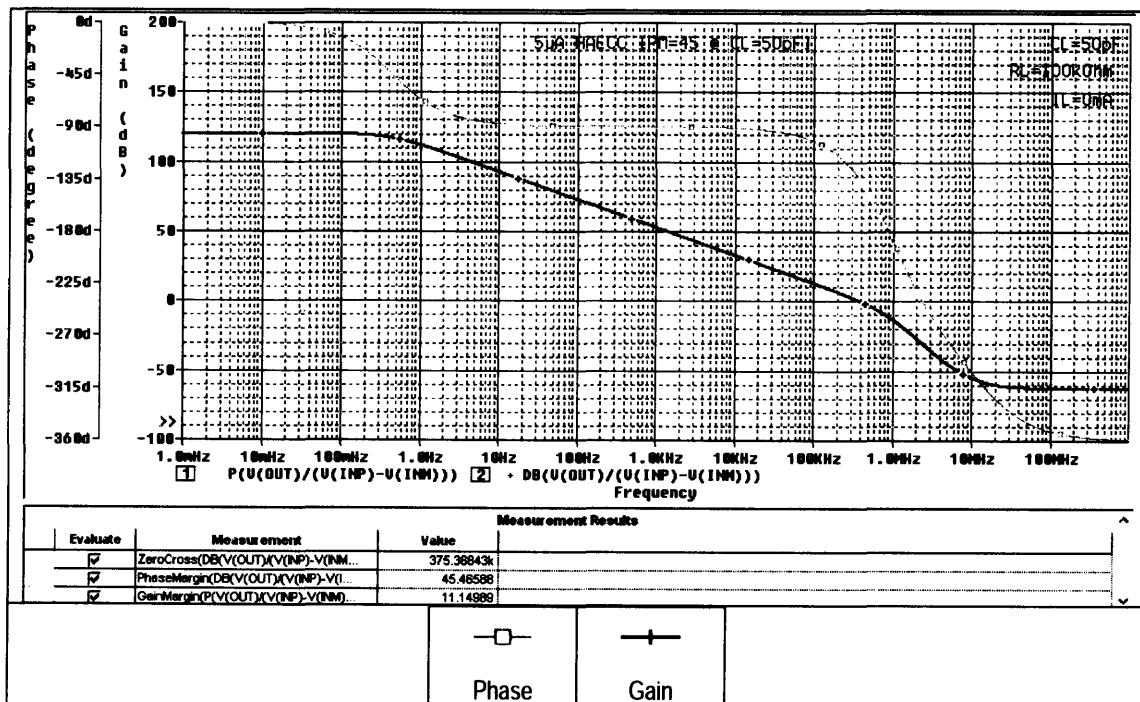

Figure 6-2: Frequency Response of 5 μ A Micropower Op Amp with HAECC Compensated Down to Have $\Phi_M = 45^\circ$ at 50pF Load to Compare with MIC861

5 μ A Op Amp [PM=45 @ CL=50pF, vs MIC861]		Frequency Response			
		C _L = 0pF, R _L = 100k Ω		C _L = 50pF, R _L = 100k Ω	
		GBW (kHz)	Φ_M (°)	GBW (kHz)	Φ_M (°)
Simple Miller Compensation	<i>SMC</i>	329	81	267	45
Hybrid Explicit Cascode Compensation	<i>HECC</i>	369	79	327	46
Hybrid Asymmetric Embedded Cascode Compensation	<i>HAECC</i>	403	72	375	45
<i>MIC861</i> [4]		350	N/A	225	≈ 45 ¹³

Table 6-4: Comparison of Unity Gain Frequency between the Proposed 5 μ A Micropower Op Amps and MIC861

Future Work

For the same op amp architecture, different frequency compensation schemes result in different performance characteristics, especially the speed. One potential direction to further this project is to improve the biasing scheme of the output stage. A more power-saving biasing scheme for the output stage can help increase the speed of op amps because more current can be allocated to the output pair and the differential pair. Another potential improvement is to research on novel compensation techniques. This work includes the optimization scheme in compensating an op amp such as how to minimize the capacitors in the simple Miller path in the hybrid compensation while guaranteeing op amp stability.

¹³ The phase margin is not given in [4]. It is estimated from the datasheet that the IC has 2-3 periods of decayed oscillation in the small-signal pulse response at 50pF load.

Appendices

- Appendix A** Schematics and Characteristics of 20 μ A Micropower Op Amp with Simple Miller Compensation (SMC)
- Appendix B** Schematics and Characteristics of 20 μ A Micropower Op Amp with Hybrid Explicit Cascode Compensation (HECC)
- Appendix C** Schematics and Characteristics of 20 μ A Micropower Op Amp with Hybrid Symmetric Embedded Cascode Compensation (HSECC)
- Appendix D** Schematics and Characteristics of 20 μ A Micropower Op Amp with Hybrid Asymmetric Embedded Cascode Compensation (HAECC)

Appendix A Schematics and Characteristics of 20 μ A Micropower Op Amp with Simple Miller Compensation (SMC)

LIST OF FIGURES IN APPENDIX A

Table A: Characteristics of 20 μ A Micropower Op Amp with Simple Miller Compensation (SMC) from Simulation.....	79
Figure A-1: Schematic of 20 μ A Micropower Op Amp with Simple Miller Compensation (SMC)	81
Figure A-2: Frequency Response with $C_L=100\text{pF}$ and $R_L=100\text{k}\Omega$	82
Figure A-3: Frequency Response with $C_L=0, 10, 100, 200, 500\text{pF}$ and $R_L=100\text{k}\Omega$	83
Figure A-4: CMRR vs Frequency with $V_{IN}=0, 0.65, 1.3\text{V}$	84
Figure A-5: PSRR+ vs Frequency with $V_{IN}=0, 0.65, 1.3\text{V}$	85
Figure A-6: PSRR- vs Frequency with $V_{IN}=0, 0.65, 1.3\text{V}$	85
Figure A-7: Small-Signal Transient Response with $C_L=100\text{pF}$ and $R_L=100\text{k}\Omega$	86
Figure A-8: Small-Signal Transient Response with $C_L=0, 10, 100\text{pF}$ and $R_L=100\text{k}\Omega$	86
Figure A-9: Large-Signal Transient Response with $C_L=100\text{pF}$ and $R_L=100\text{k}\Omega$	87
Figure A-10: Large-Signal Transient Response with $C_L=0, 10, 100\text{pF}$ and $R_L=100\text{k}\Omega$..	87
Figure A-11: Output Transistors Current vs I_{LOAD}	88
Figure A-12: Rail-to-Rail Output Voltage (v_{IN} and v_{OUT} with $A_V=5$)	88
Figure A-13: Positive Output Voltage Swing vs I_{SOURCE}	89
Figure A-14: Negative Output Voltage Swing vs I_{SINK}	89
Figure A-15: Short-Circuit Source Current vs Supply Voltage.....	90
Figure A-16: Short-Circuit Sink Current vs Supply Voltage.....	90
Figure A-17: Frequency Response with $C_L=0\text{pF}$ and $R_L=100\text{k}\Omega$ @ $I_L=-1.0, -0.5, 0.0, 0.5, 1.0\text{mA}$	91
Figure A-18: Frequency Response with $C_L=10\text{pF}$ and $R_L=100\text{k}\Omega$ @ $I_L=-1.0, -0.5, 0.0, 0.5, 1.0\text{mA}$	91

Figure A-19: Frequency Response with $C_L=100\text{pF}$ and $R_L=100\text{k}\Omega$ @ $I_L=-1.0, -0.5, 0.0,$ 0.5, 1.0mA.....	91
Figure A-20: Schematic of Bias Cell for $20\mu\text{A}$ Op Amp with Simple Miller Compensation (SMC)	92
Figure A-21: Reference Current and Reference Voltages vs Supply Voltage.....	93
Figure A-22: Quiescent Current in Output Pair and Tail Current in Differential Input Pair vs Supply Voltage	94

Table A: Characteristics of 20 μ A Micropower Op Amp with Simple Miller Compensation (SMC) from Simulation

Simulation results are at 25°C. $V_{DD} = 2.5V$ and $V_{SS} = 0V$.						
Primary Characteristics						
Symbol	Parameter	Condition	Value		Unit	
			Specified	Simulated		
GBW^{14}	Gain Bandwidth Product	$C_L = 100pF$ $R_L = 100k\Omega$	> 0.3	0.360 ($\Phi_M = 61.5^\circ$)	MHz	
A_{VOL}	Large-Signal Voltage Gain (DC Open-Loop Gain)	$C_L = 100pF$ $R_L = 100k\Omega$	> 100	122	dB	
I_S	Supply Current	No Load	< 21	19.95	μA	
V_{INCM}^{15}	Input Common-Mode Range	-	> $V_{DD} - 1.25V$ and must include negative supply voltage	1.3 and includes negative supply voltage	V	
V_{OS}^{16}	(Untrimmed) Input Offset Voltage	$V_{INCM} = 0.65V$	< 5	4.18	mV	
V_{OUT}	V_{OUTH}	High Output Voltage	$I_{SOURCE} = 1.0mA$	> $V_{DD} - 0.3V$	2.34	V
	V_{OUTL}	Low Output Voltage	$I_{SINK} = 1.0mA$	< $V_{SS} + 0.3V$	0.19	V
I_{SOURCE}^{17}	Output Source Current	$C_L = 100pF$ $R_L = 100k\Omega$	> 1.0	1.55	mA	
I_{SINK}	Output Sink Current	$C_L = 100pF$ $R_L = 100k\Omega$	> 1.0	1.04	mA	
Secondary Characteristics						
Symbol	Parameter	Condition	Value		Unit	
			Specified	Simulated		
SR+	Positive Going Slew Rate	$A_V = 1V/V, 1V$ Step	> 0.15	0.223	V/ μs	
SR-	Negative Going Slew Rate	$A_V = 1V/V, 1V$ Step	< -0.15	-0.236	V/ μs	

¹⁴ Gain bandwidth product per supply current $GBW/I_S = 18MHz/mA @ C_L = 100pF$.

¹⁵ Verified by CMRR simulation in Figure A-4.

¹⁶ Conservative estimate from calculation.

¹⁷ Maximum output source current is measured when the other transistor in the output pair starts to turn off, i.e. its current goes down to as low as $1\mu A$.

CMRR	Common Mode Rejection Ratio	@ DC	> 60	144	dB
PSRR+	Positive Power Supply Rejection Ratio	@ DC	> 60	84.5	dB
PSRR-	Negative Power Supply Rejection Ratio	@ DC	> 60	99.4	dB
t_s	0.1% Settling Time	$A_v = 1V/V, 1V$ Step	< 10	5.29	μs

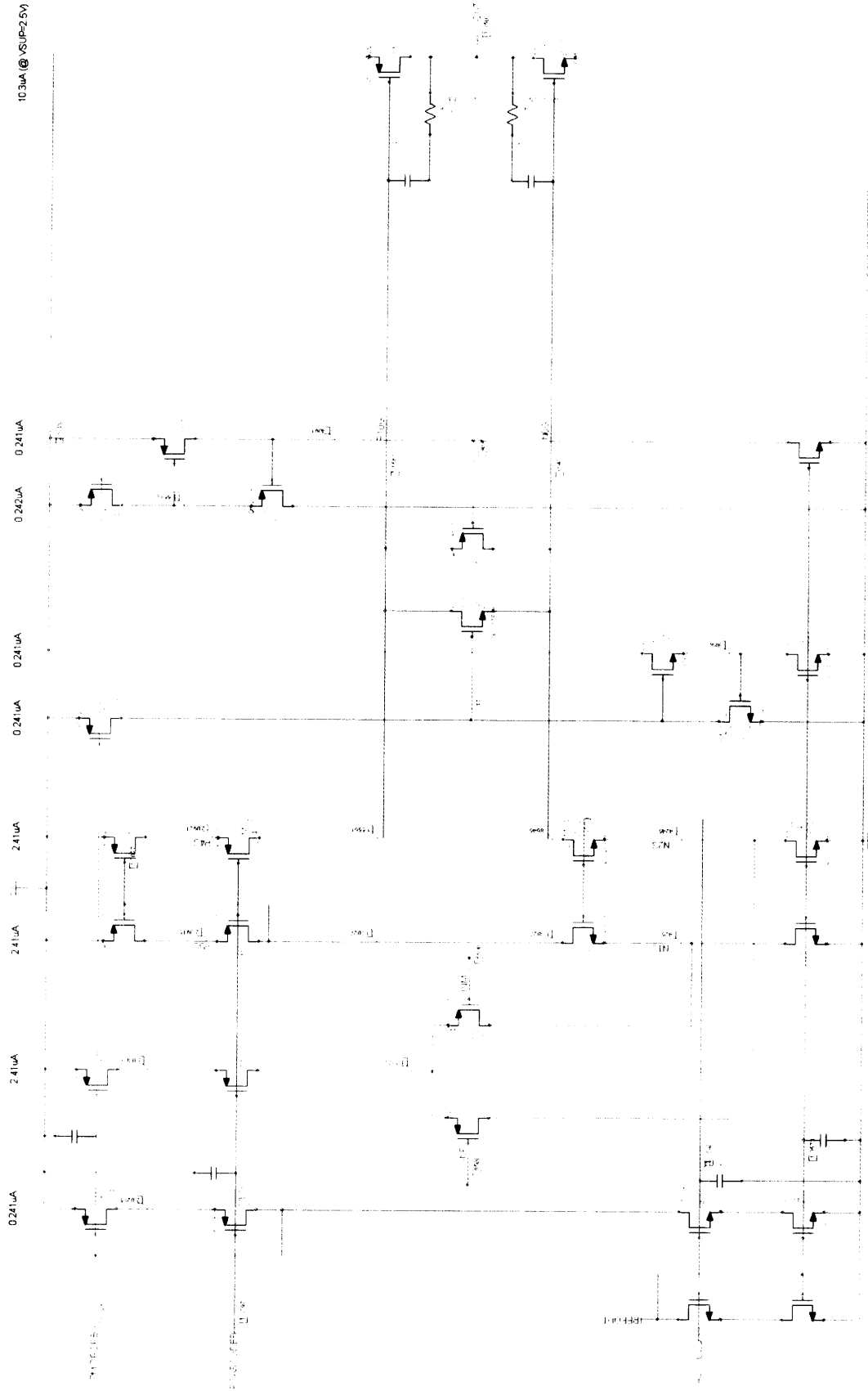

Figure A-1: Schematic of 20 μA Micropower Op Amp with Simple Miller Compensation (SMC)

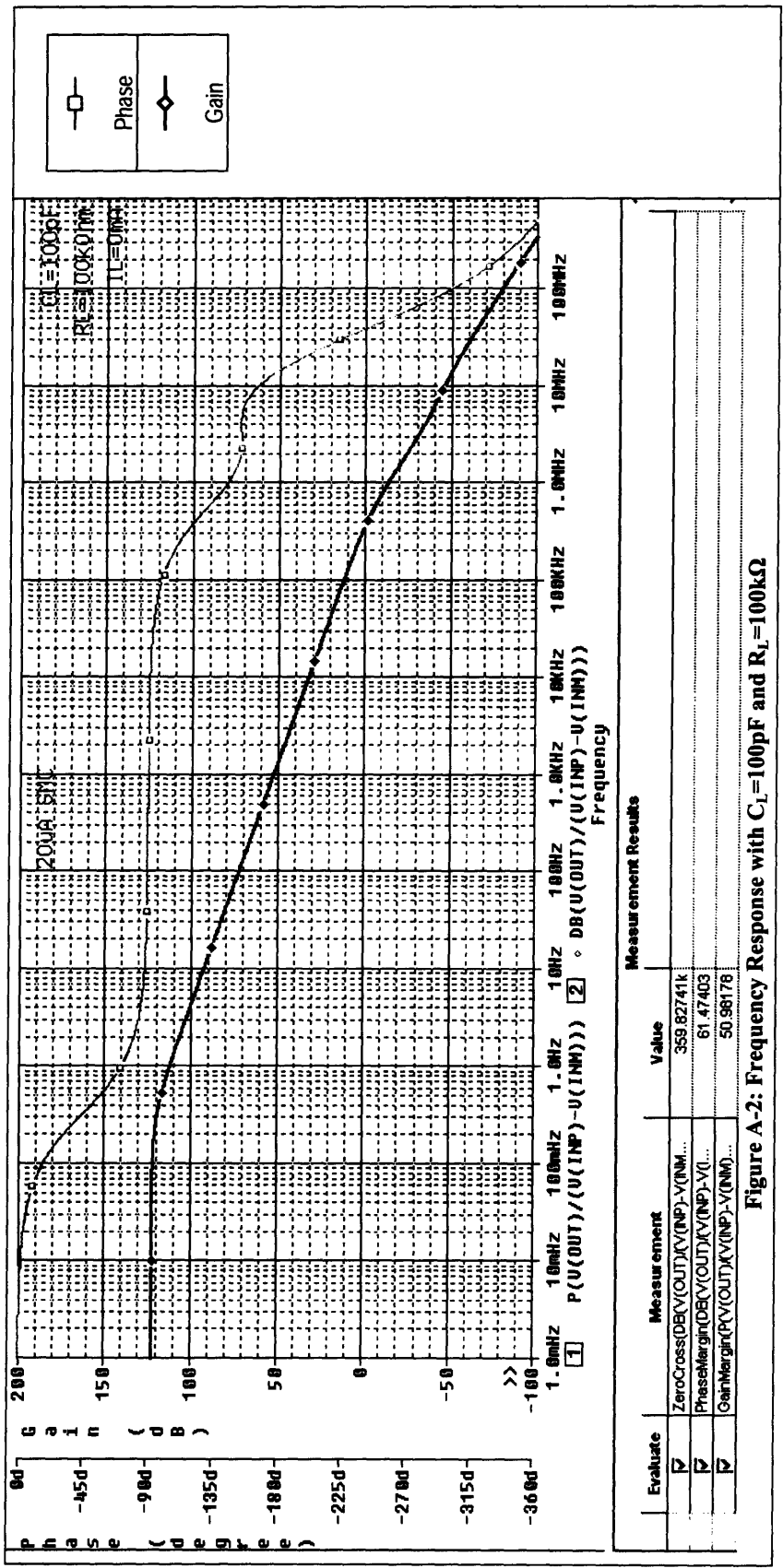

Figure A-2. Frequency Response with $C_L=100\text{pF}$ and $R_L=100\text{k}\Omega$

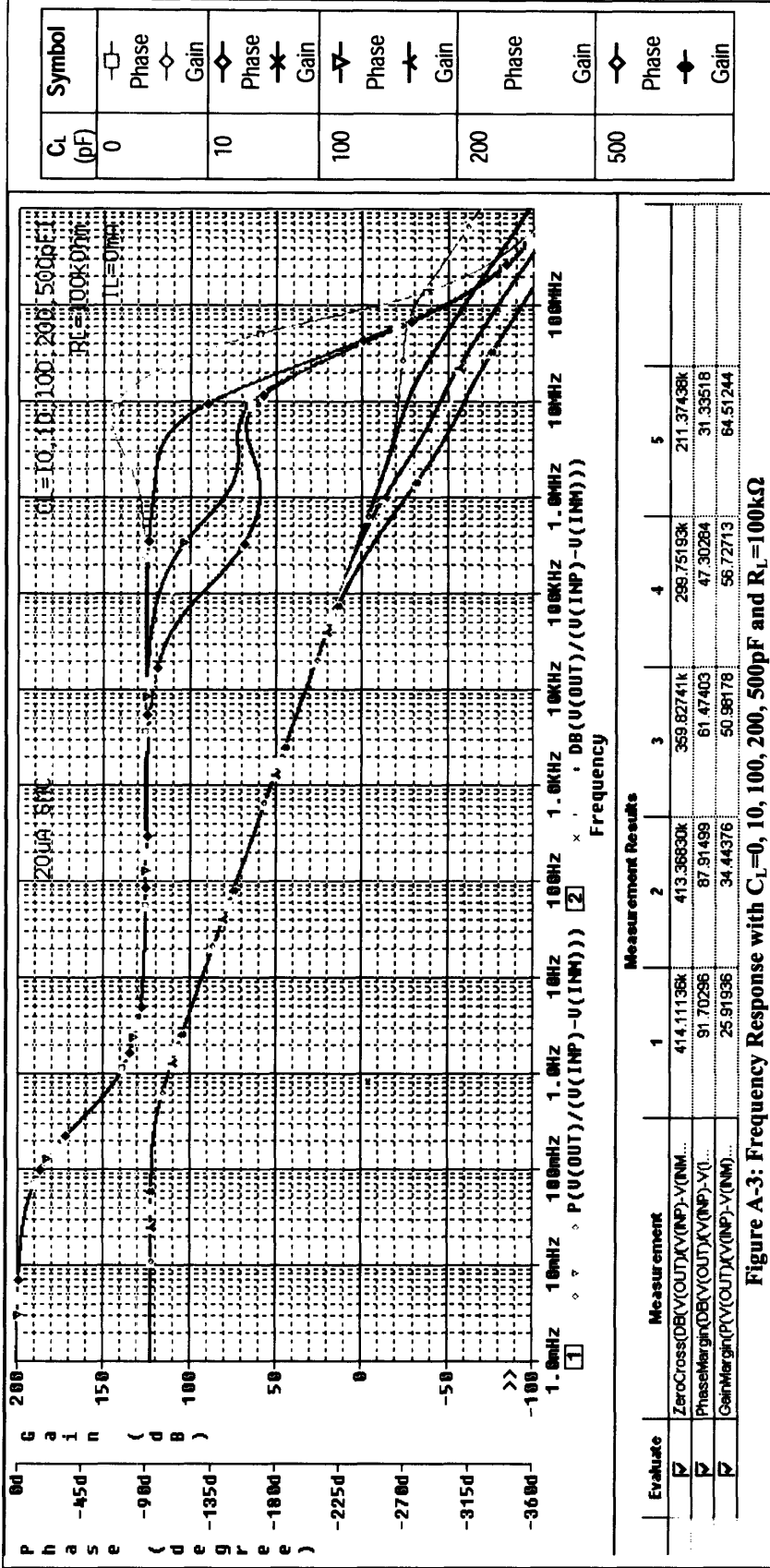

Figure A-3: Frequency Response with $C_L=0, 10, 100, 200, 500\text{pF}$ and $R_L=100\text{k}\Omega$

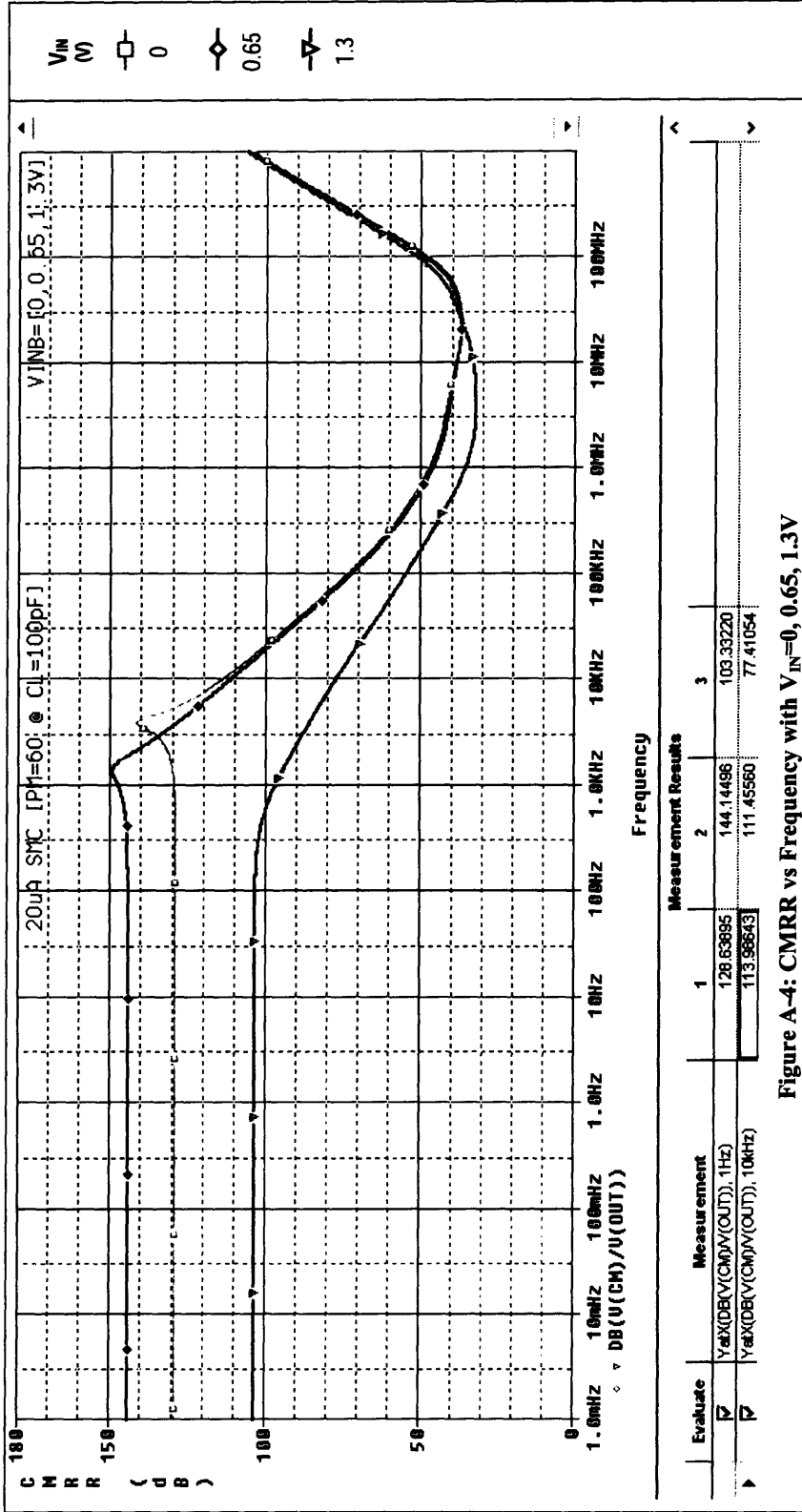

Figure A-4: CMRR vs Frequency with $V_{IN}=0, 0.65, 1.3V$

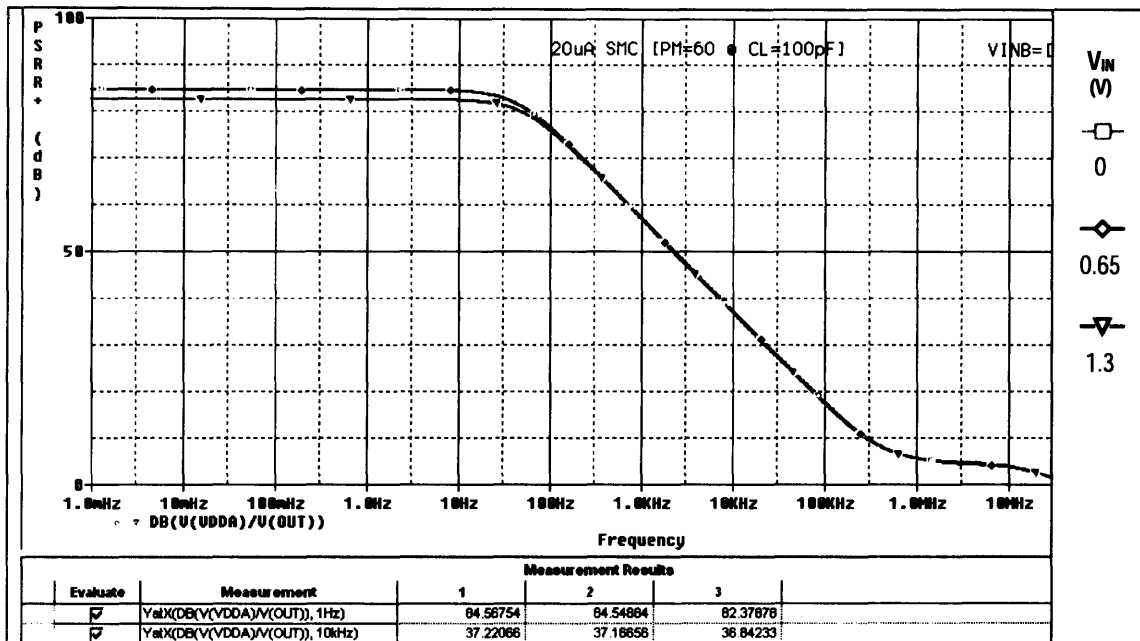

Figure A-5: PSRR+ vs Frequency with $V_{IN}=0, 0.65, 1.3V$

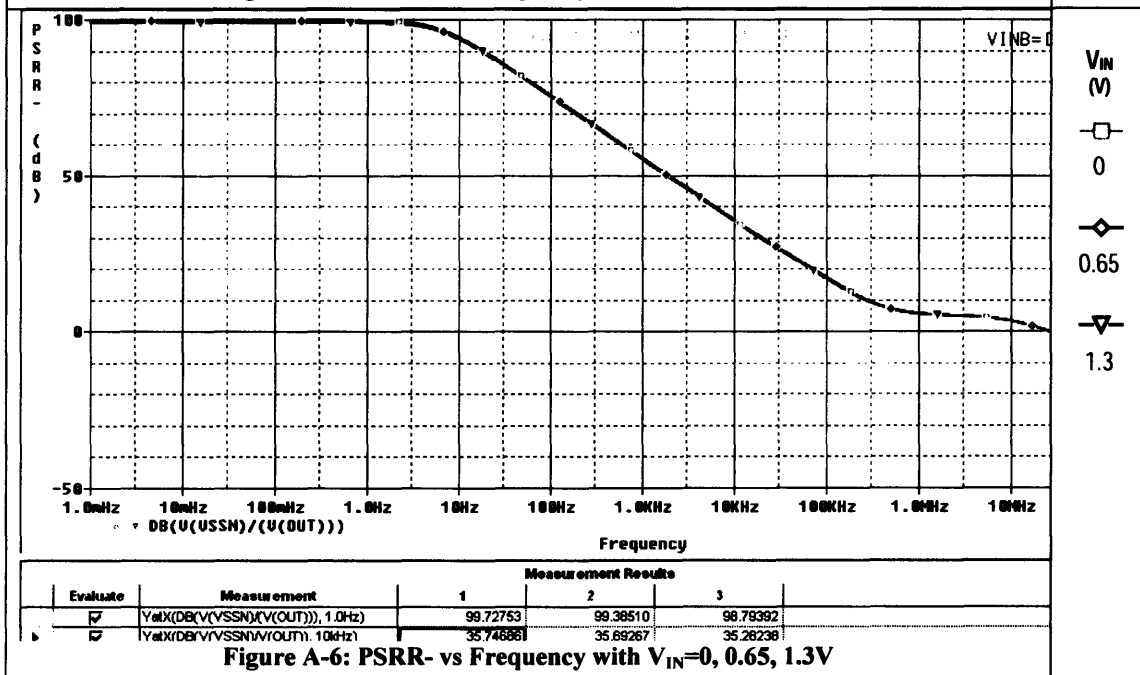
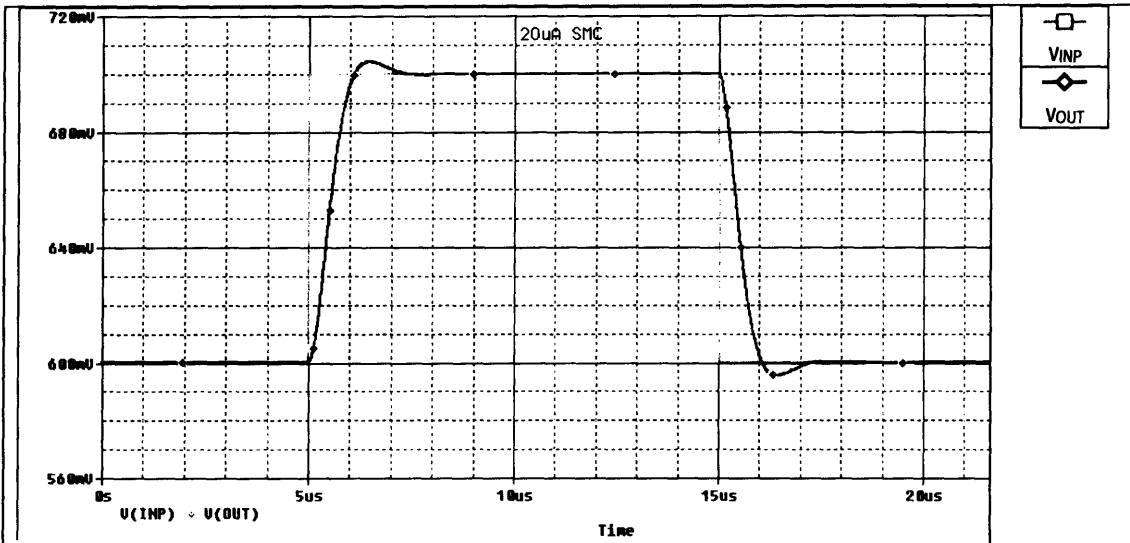
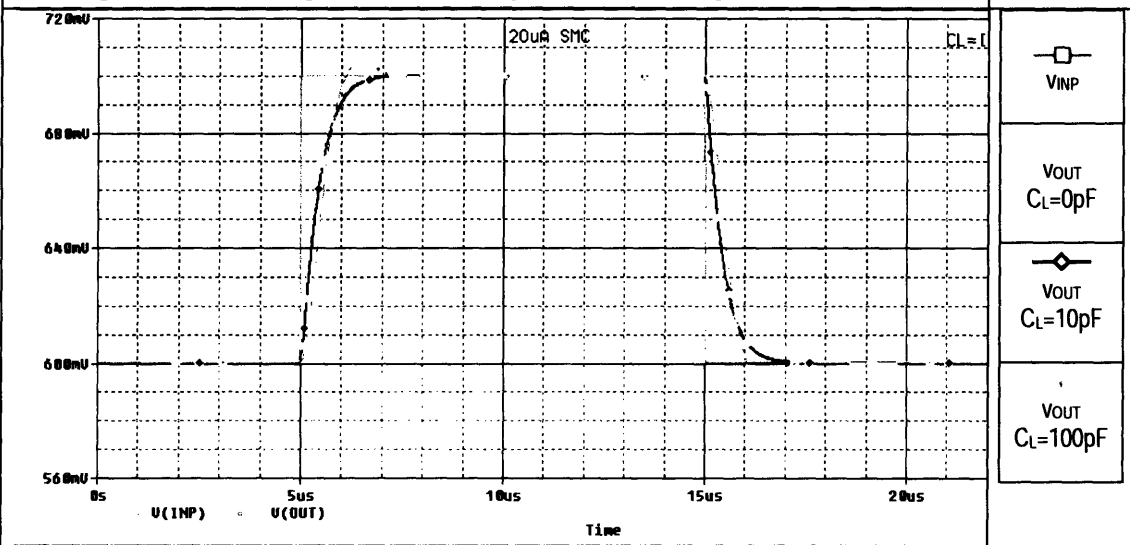

Figure A-6: PSRR- vs Frequency with $V_{IN}=0, 0.65, 1.3V$



Measurement Results		
Evaluate	Measurement	Value
<input checked="" type="checkbox"/>	SettlingTime XRange(V(OUT), 0.1, Su...	3.30049u

Figure A-7: Small-Signal Transient Response with $C_L=100\text{pF}$ and $R_L=100\text{k}\Omega$



Measurement Results			
Evaluate	Measurement	1	2
<input checked="" type="checkbox"/>	SettlingTime XRange(V(OUT), 0.1, Su...	2.80331u	2.84689u
			3.30049u

Figure A-8: Small-Signal Transient Response with $C_L=0, 10, 100\text{pF}$ and $R_L=100\text{k}\Omega$

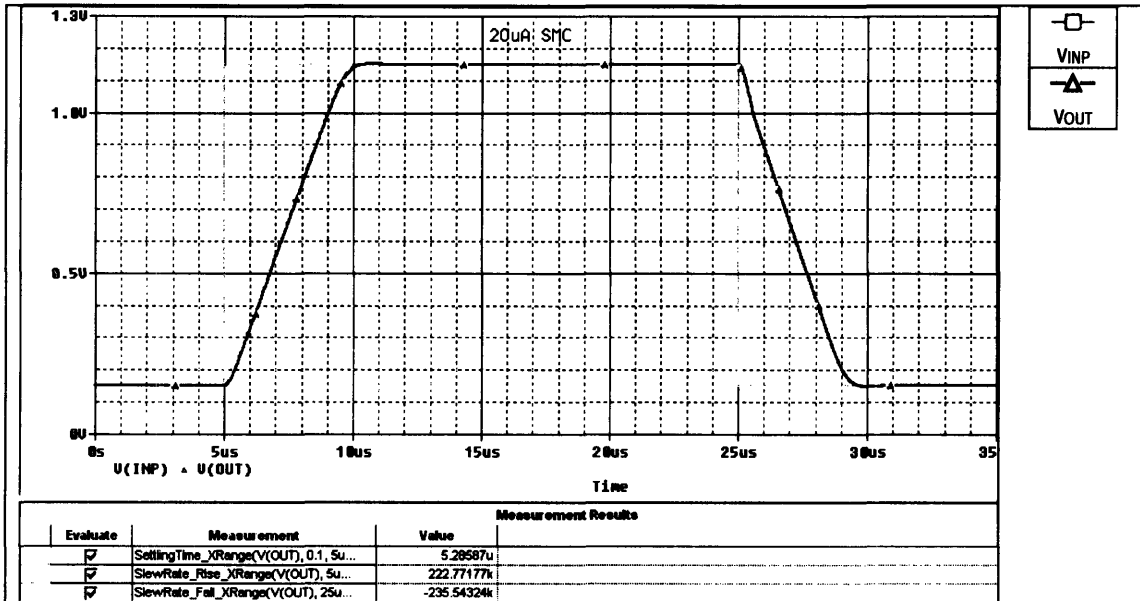

Figure A-9: Large-Signal Transient Response with $C_L=100\text{pF}$ and $R_L=100\text{k}\Omega$

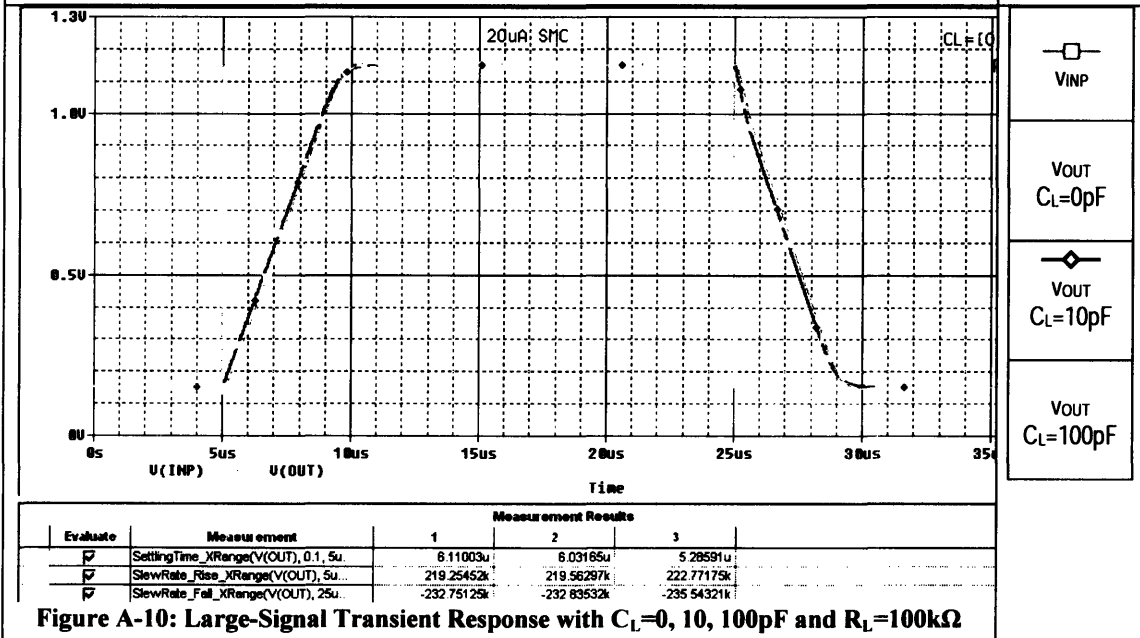

Figure A-10: Large-Signal Transient Response with $C_L=0, 10, 100\text{pF}$ and $R_L=100\text{k}\Omega$

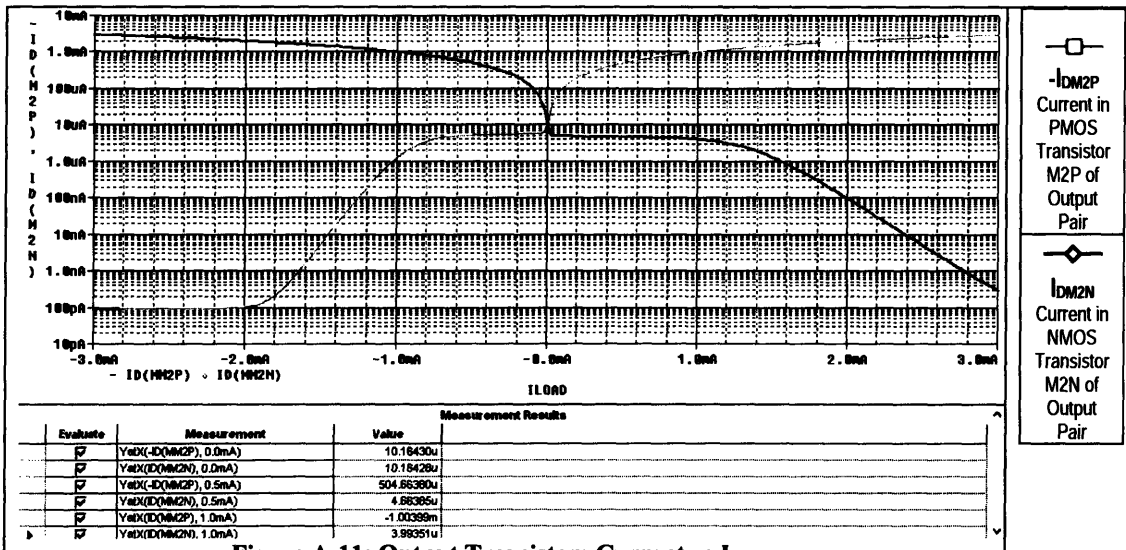

Figure A-11: Output Transistors Current vs I_{LOAD}

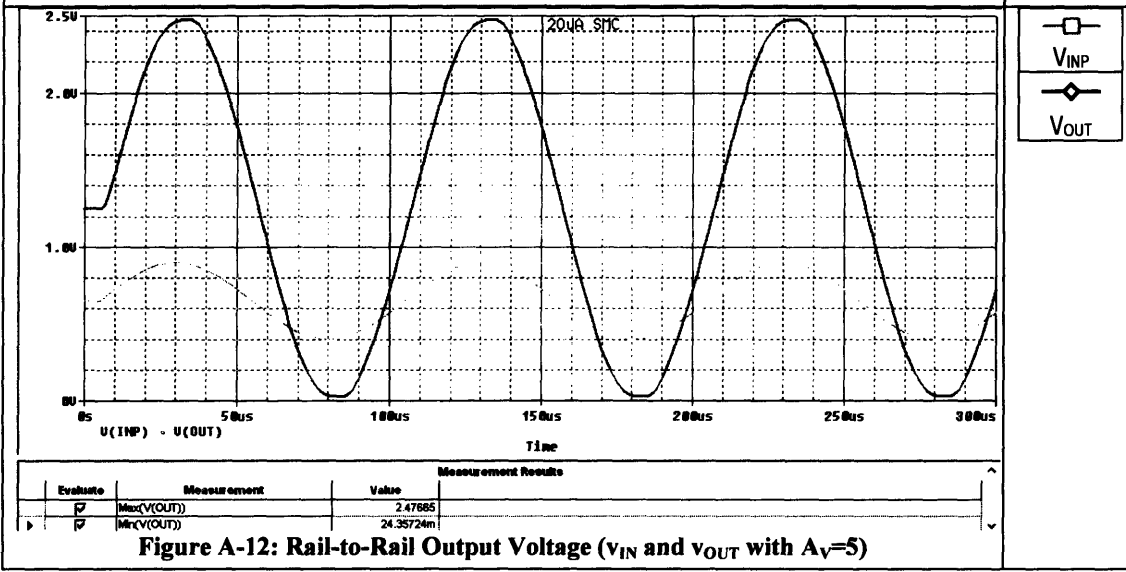

Figure A-12: Rail-to-Rail Output Voltage (V_{IN} and V_{OUT} with $A_V=5$)

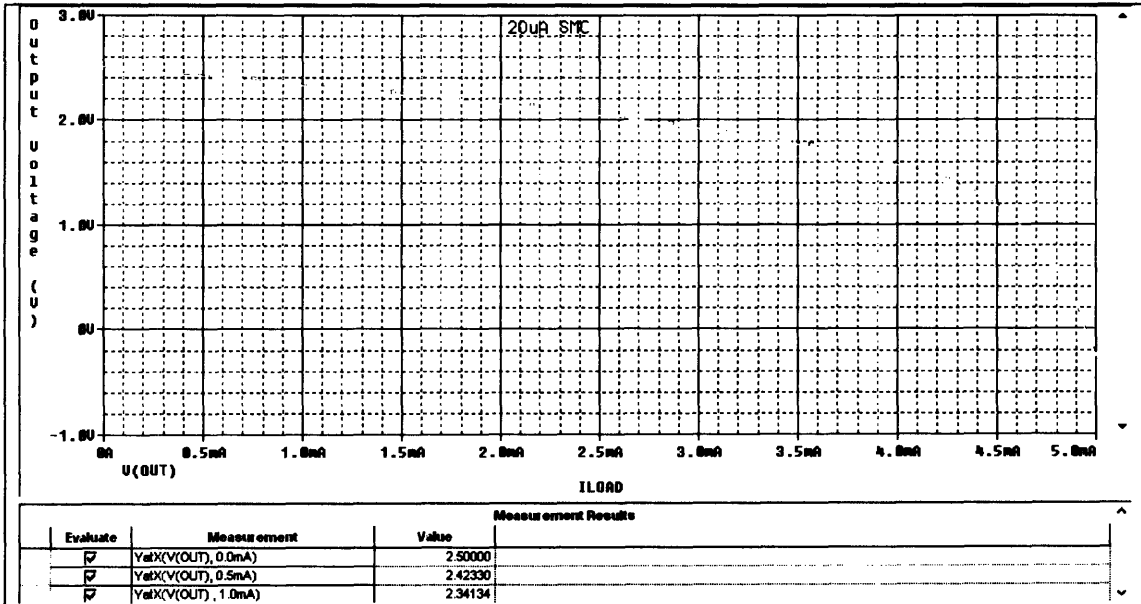

Figure A-13: Positive Output Voltage Swing vs I_{SOURCE}

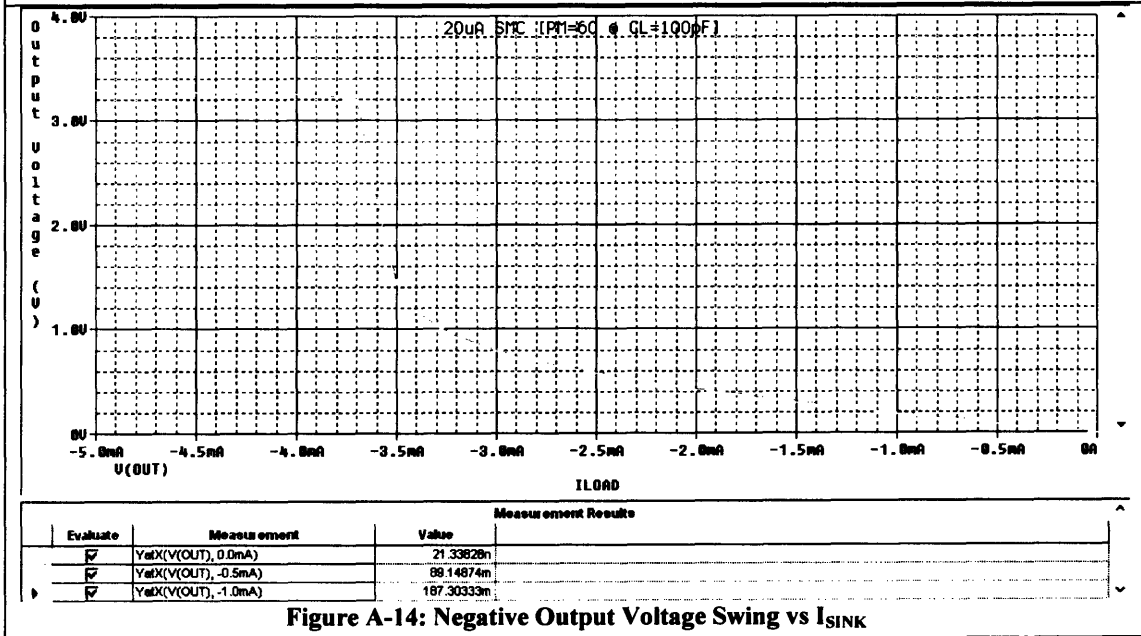

Figure A-14: Negative Output Voltage Swing vs I_{SINK}

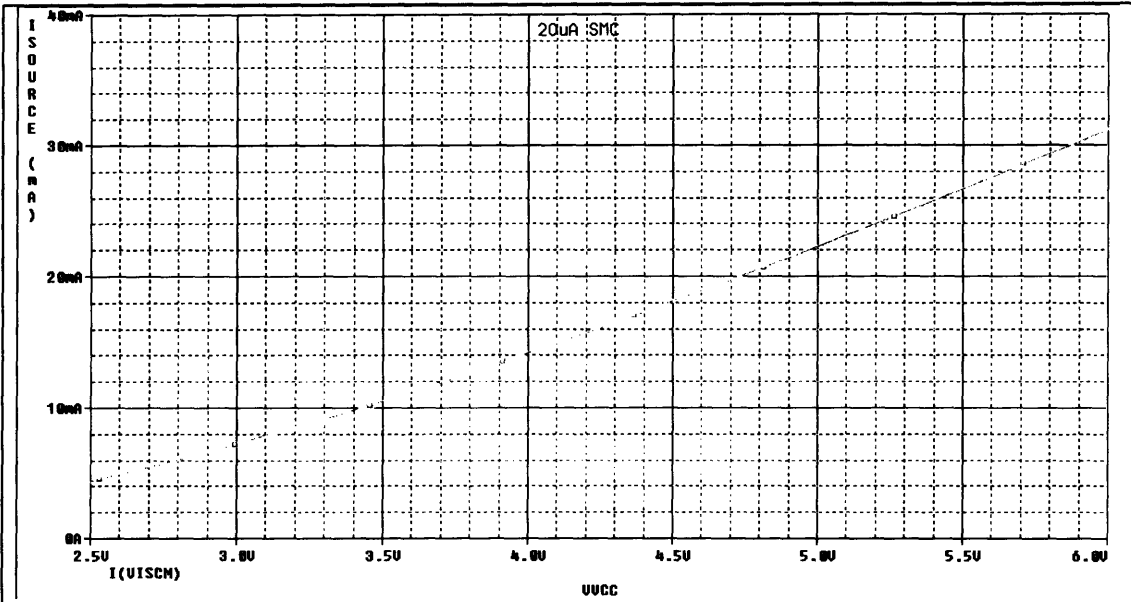

Figure A-15: Short-Circuit Source Current vs Supply Voltage

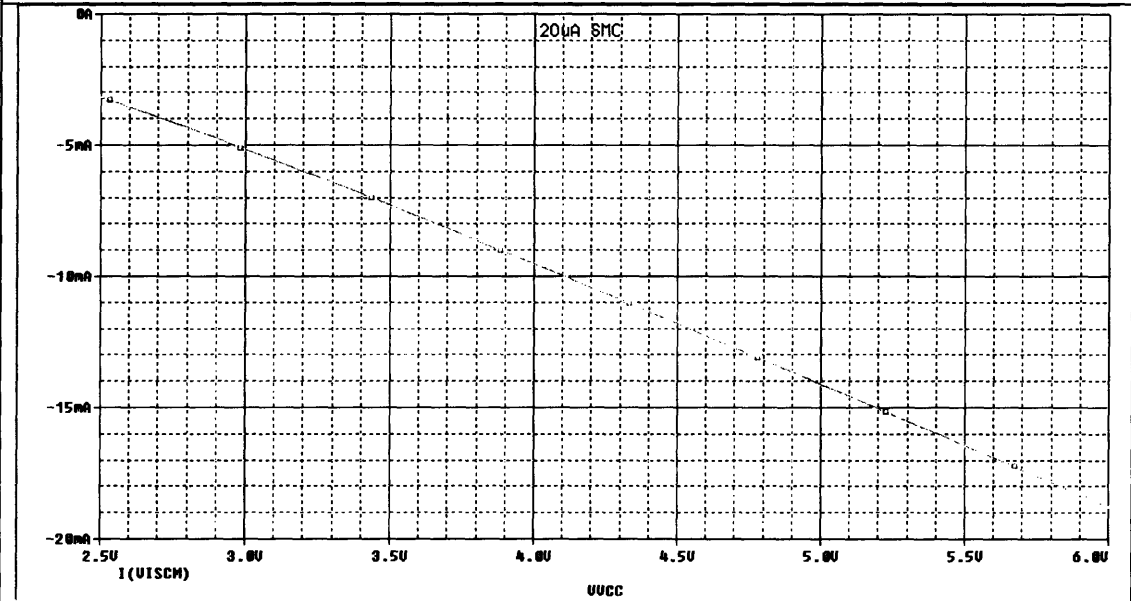
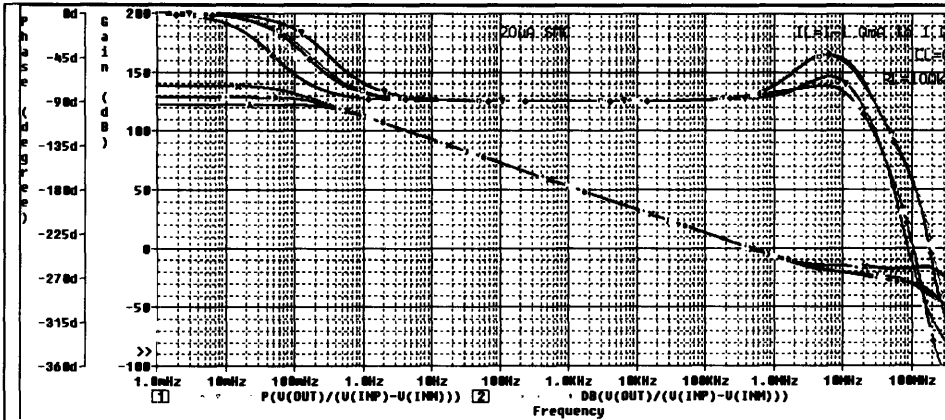
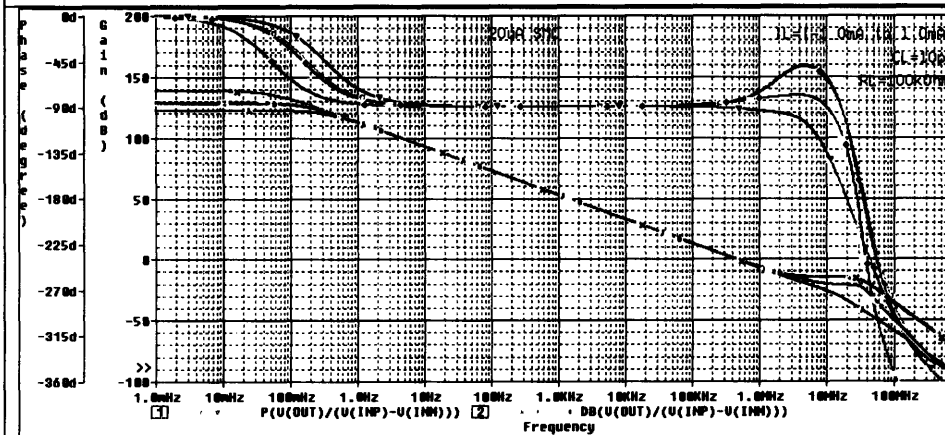

Figure A-16: Short-Circuit Sink Current vs Supply Voltage



Measurement Results						
Evaluate	Measurement	1	2	3	4	5
<input checked="" type="checkbox"/>	ZeroCross(DB(V(OUT)/(V(INP)-V(INM))-V(INM))	418.07883k	421.28463k	414.11136k	433.43862k	430.16475k
<input checked="" type="checkbox"/>	PhaseMargin(DB(V(OUT)/(V(INP)-V(INM))-V(INM))	95.50545	95.68010	91.70296	94.80856	94.91432
<input checked="" type="checkbox"/>	GainMargin(P(V(OUT)/(V(INP)-V(INM))-V(INM))	18.59197	17.48470	25.91536	28.84230	28.88374
<input checked="" type="checkbox"/>	PeakDB(V(OUT)/(V(INP)-V(INM))-V(INM))	-17.69259	-16.84812	<Evaluation Failed>	<Evaluation Failed>	<Evaluation Failed>

Figure A-17: Frequency Response with $C_L=0\text{pF}$ and $R_L=100\text{k}\Omega$ @ $I_L=-1.0, -0.5, 0.0, 0.5, 1.0\text{mA}$



Measurement Results						
Evaluate	Measurement	1	2	3	4	5
<input checked="" type="checkbox"/>	ZeroCross(DB(V(OUT)/(V(INP)-V(INM))-V(INM))	418.21424k	421.67050k	413.36830k	433.86428k	430.45888k
<input checked="" type="checkbox"/>	PhaseMargin(DB(V(OUT)/(V(INP)-V(INM))-V(INM))	94.98181	95.22150	87.91499	94.49051	94.57436
<input checked="" type="checkbox"/>	GainMargin(P(V(OUT)/(V(INP)-V(INM))-V(INM))	20.10780	18.59552	34.44376	22.72739	22.81272

Figure A-18: Frequency Response with $C_L=10\text{pF}$ and $R_L=100\text{k}\Omega$ @ $I_L=-1.0, -0.5, 0.0, 0.5, 1.0\text{mA}$

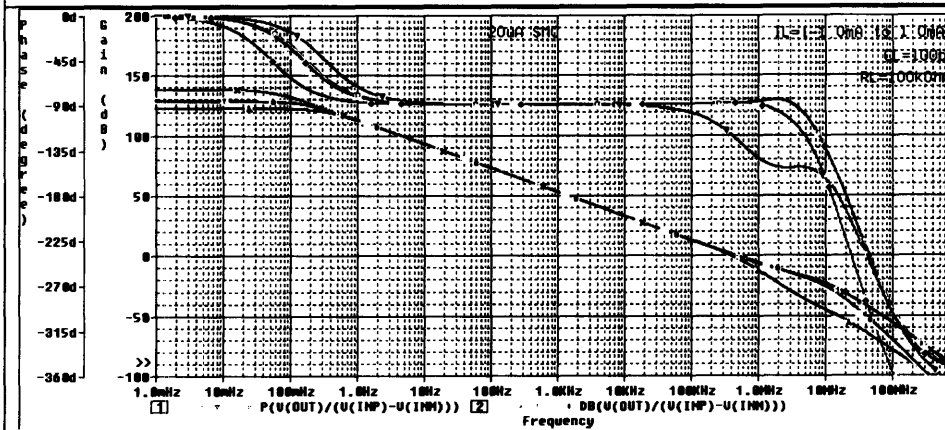

Measurement Results						
Evaluate	Measurement	1	2	3	4	5
<input checked="" type="checkbox"/>	ZeroCross(DB(V(OUT)/(V(INP)-V(INM))-V(INM))	417.92143k	423.92718k	359.82741k	436.85943k	432.37773k
<input checked="" type="checkbox"/>	PhaseMargin(DB(V(OUT)/(V(INP)-V(INM))-V(INM))	90.34536	91.01890	61.47403	90.87716	91.47514
<input checked="" type="checkbox"/>	GainMargin(P(V(OUT)/(V(INP)-V(INM))-V(INM))	32.68659	31.95491	50.98179	29.89502	29.04385

Figure A-19: Frequency Response with $C_L=100\text{pF}$ and $R_L=100\text{k}\Omega$ @ $I_L=-1.0, -0.5, 0.0, 0.5, 1.0\text{mA}$

I_L (mA)	Symbol
-1.0	Phase Gain
-0.5	Phase Gain
0.0	Phase Gain
0.5	Phase Gain
1.0	Phase Gain

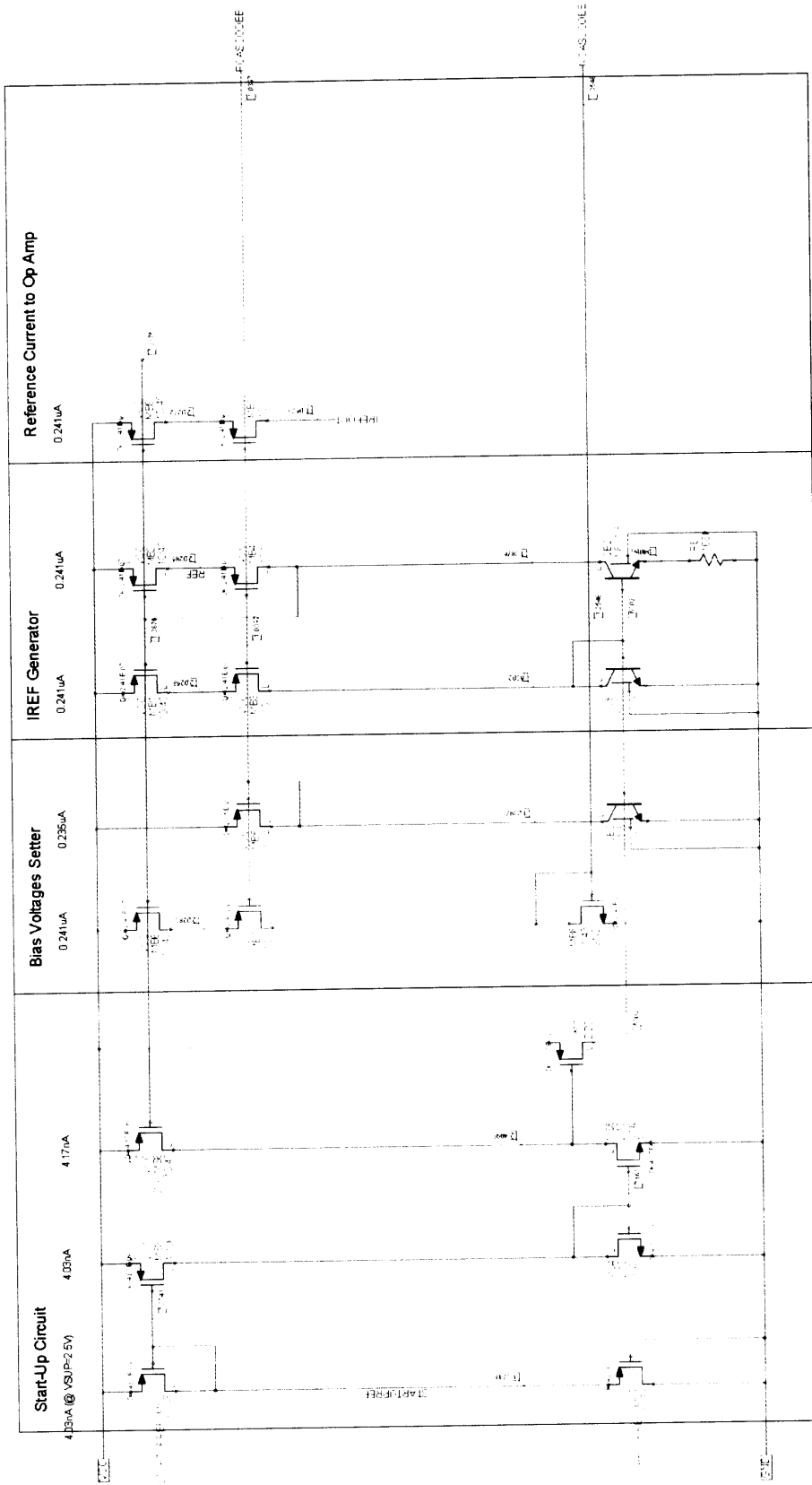

Figure A-20: Schematic of Bias Cell for 20µA Op Amp with Simple Miller Compensation (SMC)

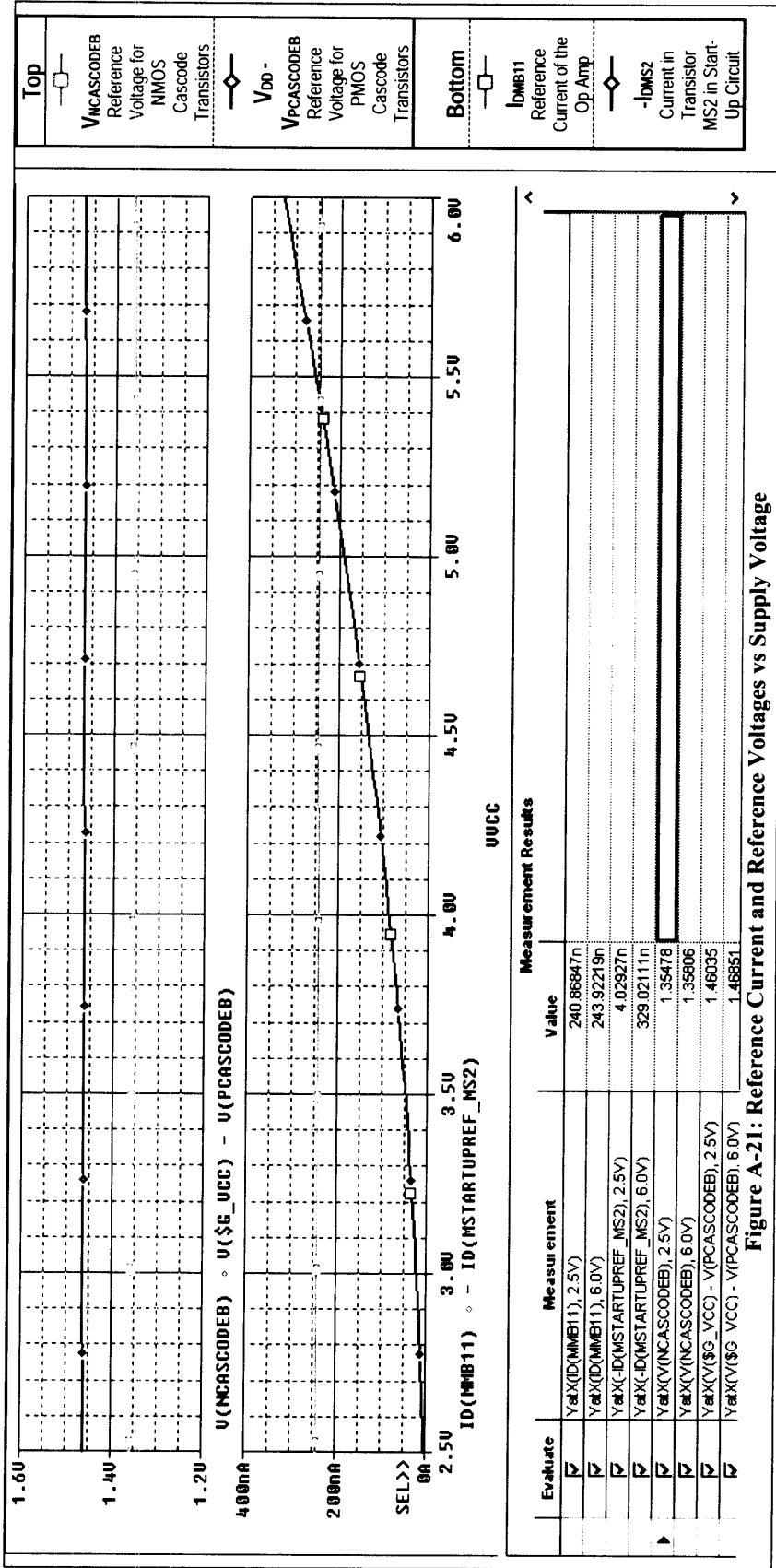

Figure A-21: Reference Current and Reference Voltages vs Supply Voltage

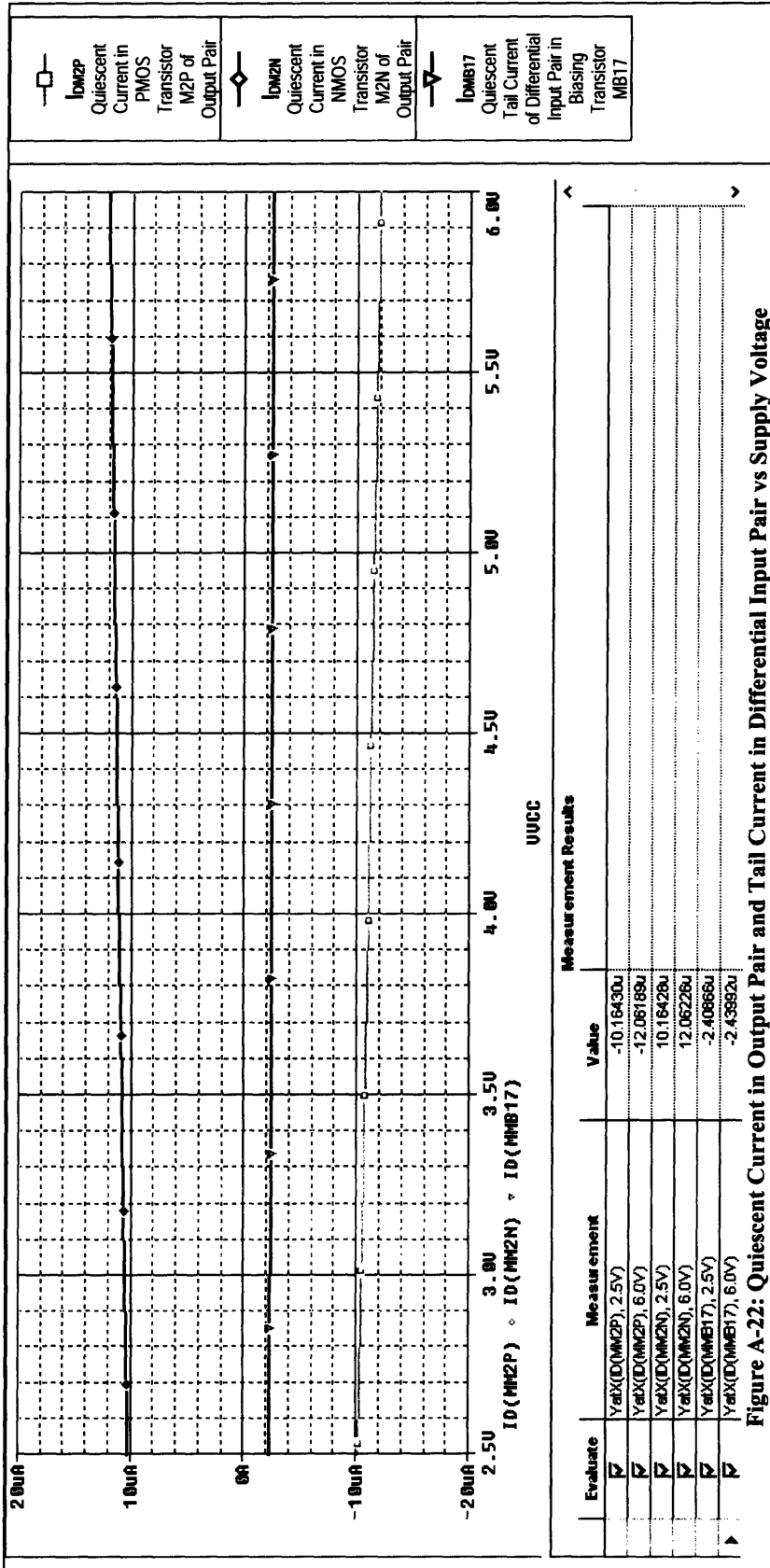

Figure A-22: Quiescent Current in Output Pair and Tail Current in Differential Input Pair vs Supply Voltage

Appendix B Schematics and Characteristics of 20 μ A Micropower Op Amp with Hybrid Explicit Cascode Compensation (HECC)

LIST OF FIGURES IN APPENDIX B

Table B: Characteristics of 20 μ A Micropower Op Amp with Hybrid Explicit Cascode Compensation (HECC) from Simulation.....	97
Figure B-1: Schematic of 20 μ A Micropower Op Amp with Hybrid Explicit Cascode Compensation (HECC)	99
Figure B-2: Frequency Response with $C_L=100\text{pF}$ and $R_L=100\text{k}\Omega$	100
Figure B-3: Frequency Response with $C_L=0, 10, 100, 200, 500\text{pF}$ and $R_L=100\text{k}\Omega$	101
Figure B-4: CMRR vs Frequency with $V_{IN}=0, 0.65, 1.3\text{V}$	102
Figure B-5: PSRR+ vs Frequency with $V_{IN}=0, 0.65, 1.3\text{V}$	103
Figure B-6: PSRR- vs Frequency with $V_{IN}=0, 0.65, 1.3\text{V}$	103
Figure B-7: Small-Signal Transient Response with $C_L=100\text{pF}$ and $R_L=100\text{k}\Omega$	104
Figure B-8: Small-Signal Transient Response with $C_L=0, 10, 100\text{pF}$ and $R_L=100\text{k}\Omega$..	104
Figure B-9: Large-Signal Transient Response with $C_L=100\text{pF}$ and $R_L=100\text{k}\Omega$	105
Figure B-10: Large-Signal Transient Response with $C_L=0, 10, 100\text{pF}$ and $R_L=100\text{k}\Omega$	105
Figure B-11: Output Transistors Current vs I_{LOAD}	106
Figure B-12: Rail-to-Rail Output Voltage (v_{IN} and v_{OUT} with $A_V=5$)	106
Figure B-13: Positive Output Voltage Swing vs I_{SOURCE}	107
Figure B-14: Negative Output Voltage Swing vs I_{SINK}	107
Figure B-15: Short-Circuit Source Current vs Supply Voltage	108
Figure B-16: Short-Circuit Sink Current vs Supply Voltage.....	108
Figure B-17: Frequency Response with $C_L=0\text{pF}$ and $R_L=100\text{k}\Omega$ @ $I_L=-1.0, -0.5, 0.0, 0.5, 1.0\text{mA}$	109

Figure B-18: Frequency Response with $C_L=10\text{pF}$ and $R_L=100\text{k}\Omega$ @ $I_L=-1.0, -0.5, 0.0,$ 0.5, 1.0mA.....	109
Figure B-19: Frequency Response with $C_L=100\text{pF}$ and $R_L=100\text{k}\Omega$ @ $I_L=-1.0, -0.5, 0.0,$ 0.5, 1.0mA.....	109
Figure B-20: Schematic of Bias Cell for $20\mu\text{A}$ Micropower Op Amp with Hybrid Explicit Cascode Compensation (HECC).....	110
Figure B-21: Reference Current and Reference Voltages vs Supply Voltage.....	111
Figure B-22: Quiescent Current in Output Pair and Tail Current in Differential Input Pair vs Supply Voltage.....	112

Table B: Characteristics of 20 μ A Micropower Op Amp with Hybrid Explicit Cascode Compensation (HECC) from Simulation

Simulation results are at 25°C. $V_{DD} = 2.5V$ and $V_{SS} = 0V$.						
Primary Characteristics						
Symbol	Parameter	Condition	Value		Unit	
			Specified	Simulated		
GBW ¹⁸	Gain Bandwidth Product	$C_L = 100pF$ $R_L = 100k\Omega$	> 0.3	0.507 ($\Phi_M = 61.2^\circ$)	MHz	
A_{VOL}	Large-Signal Voltage Gain (DC Open-Loop Gain)	$C_L = 100pF$ $R_L = 100k\Omega$	> 100	120	dB	
I_S	Supply Current	No Load	< 21	19.88	μA	
V_{INCM}^{19}	Input Common-Mode Range	-	> $V_{DD} - 1.25V$ and must include negative supply voltage	1.3 and includes negative supply voltage	V	
V_{OS}^{20}	(Untrimmed) Input Offset Voltage	$V_{INCM} = 0.65V$	< 5	4.83	mV	
V_{OUT}	V_{OUTH}	High Output Voltage	$I_{SOURCE} = 1.0mA$	> $V_{DD} - 0.3V$	2.34	V
	V_{OUTL}	Low Output Voltage	$I_{SINK} = 1.0mA$	< $V_{SS} + 0.3V$	0.19	V
I_{SOURCE}^{21}	Output Source Current	$C_L = 100pF$ $R_L = 100k\Omega$	> 1.0	1.55	mA	
I_{SINK}	Output Sink Current	$C_L = 100pF$ $R_L = 100k\Omega$	> 1.0	1.04	mA	
Secondary Characteristics						
Symbol	Parameter	Condition	Value		Unit	
			Specified	Simulated		
SR+	Positive Going Slew Rate	$A_V = 1V/V, 1V$ Step	> 0.15	0.271	V/ μs	
SR-	Negative Going Slew Rate	$A_V = 1V/V, 1V$ Step	< -0.15	-0.298	V/ μs	

¹⁸ Gain bandwidth product per supply current $GBW/I_S = 25.5MHz/mA @ C_L = 100pF$.

¹⁹ Verified by CMRR simulation in Figure B-4.

²⁰ Conservative estimate from calculation.

²¹ Maximum output source current is measured when the other transistor in the output pair starts to turn off, i.e. its current goes down to as low as $1\mu A$.

CMRR	Common Mode Rejection Ratio	@ DC	> 60	126	dB
PSRR+	Positive Power Supply Rejection Ratio	@ DC	> 60	72.4	dB
PSRR-	Negative Power Supply Rejection Ratio	@ DC	> 60	62.7	dB
t_s	0.1% Settling Time	$A_v = 1V/V$, 1V Step	< 10	4.40	μs

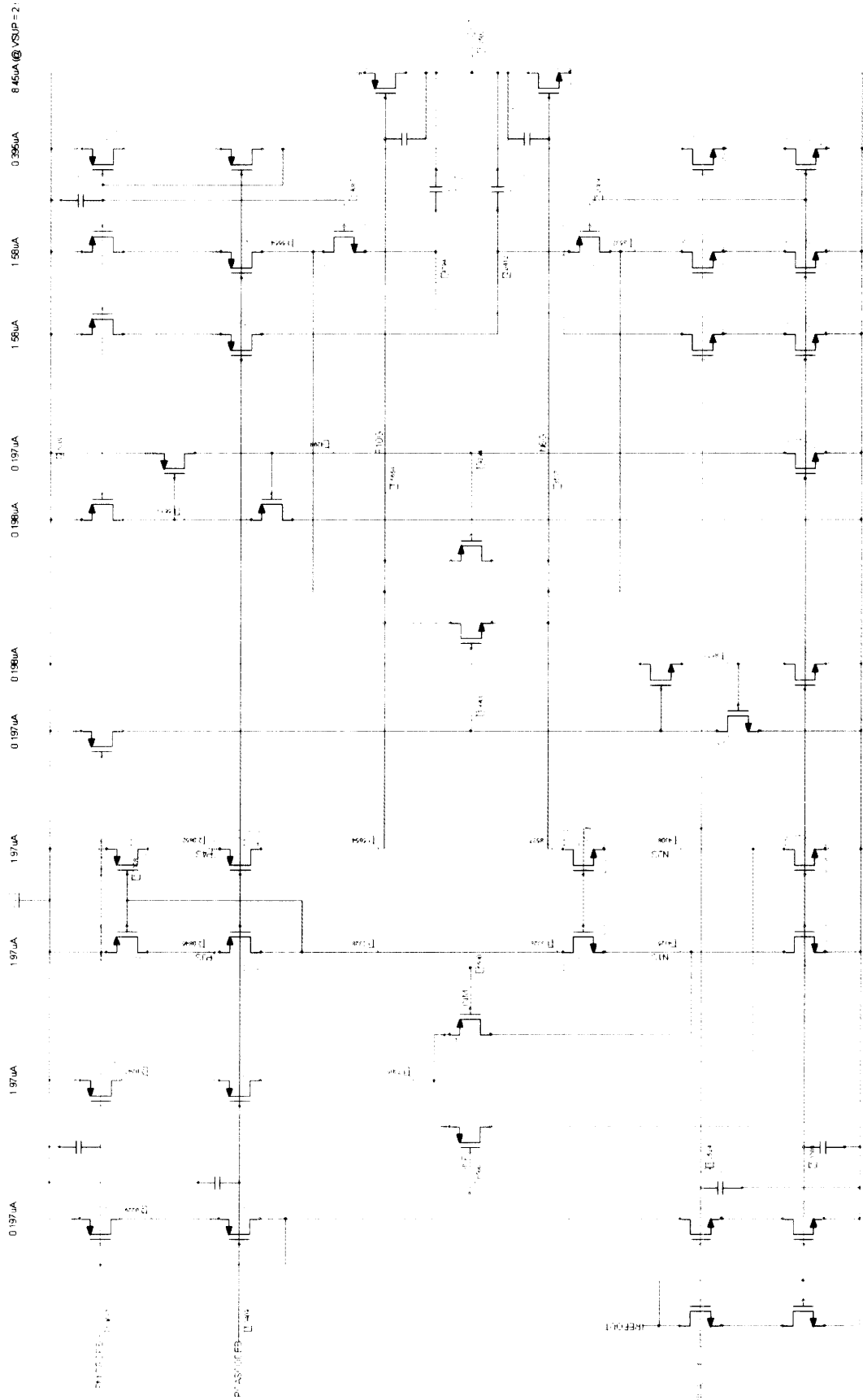

Figure B-1: Schematic of 20µA Micropower Op Amp with Hybrid Explicit Cascode Compensation (HECC)

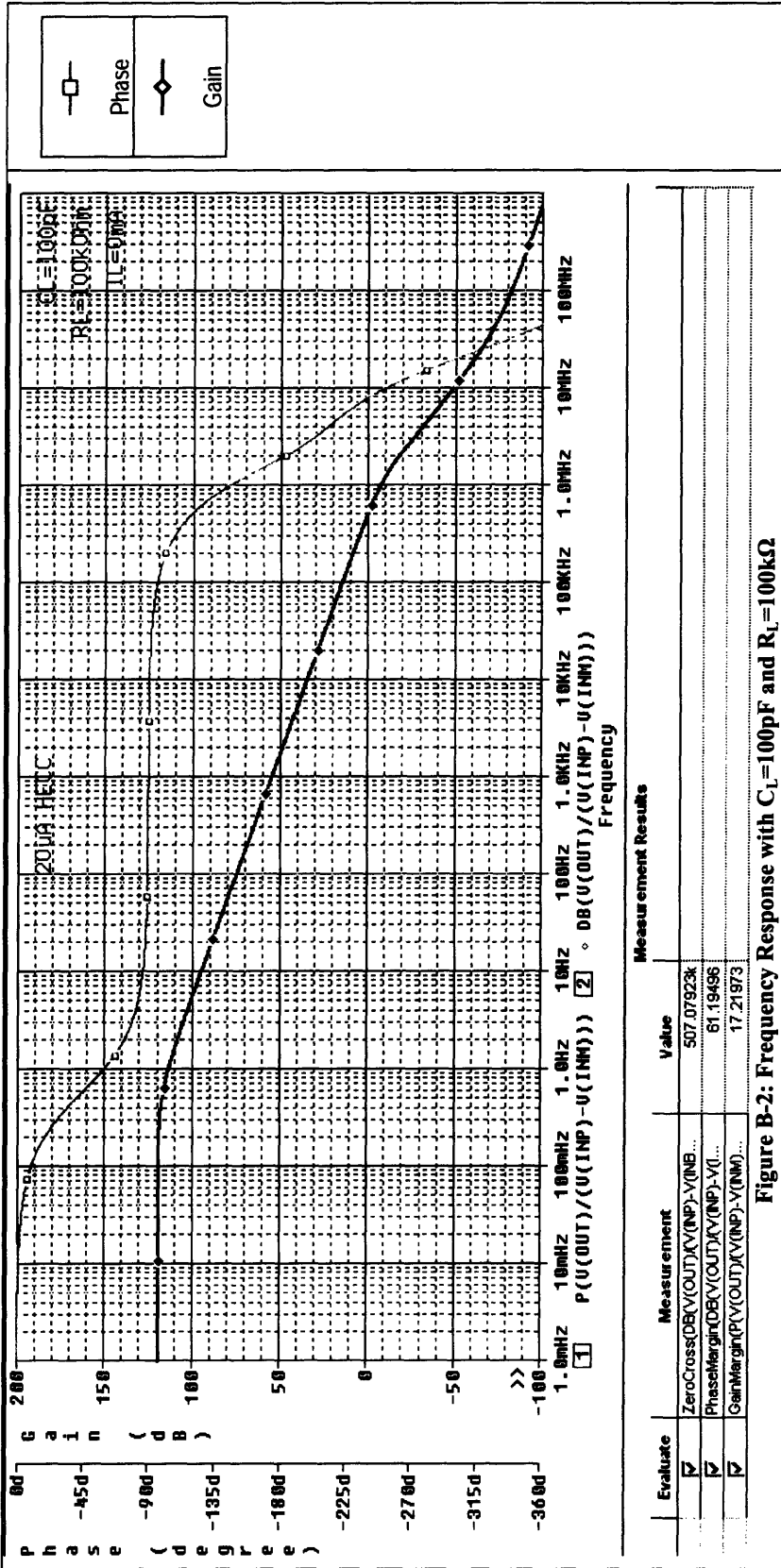

Figure B-2: Frequency Response with $C_L = 100\text{pF}$ and $R_L = 100\text{k}\Omega$

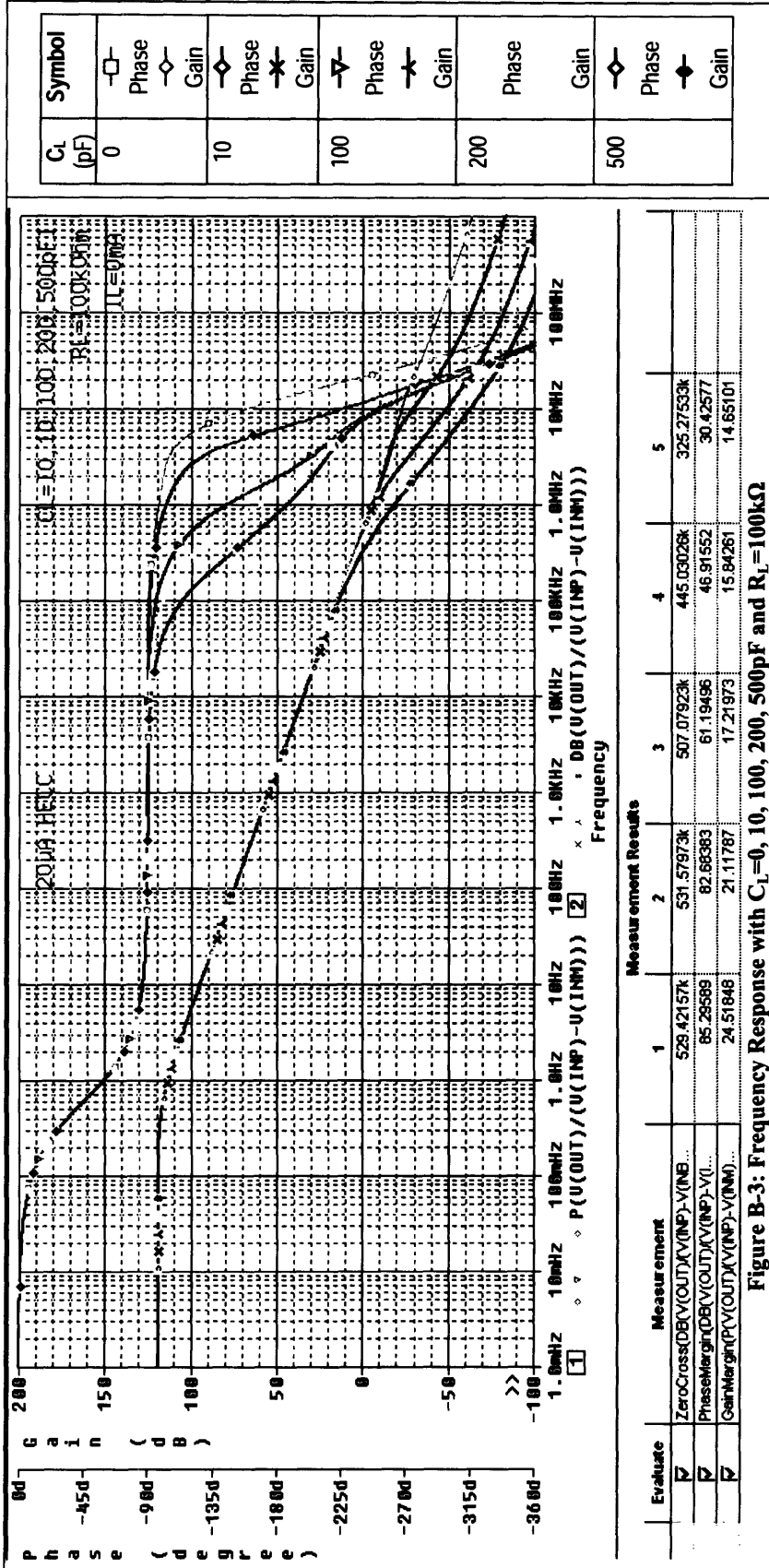

Figure B-3: Frequency Response with $C_L=0, 10, 100, 200, 500\text{pF}$ and $R_L=100\text{k}\Omega$

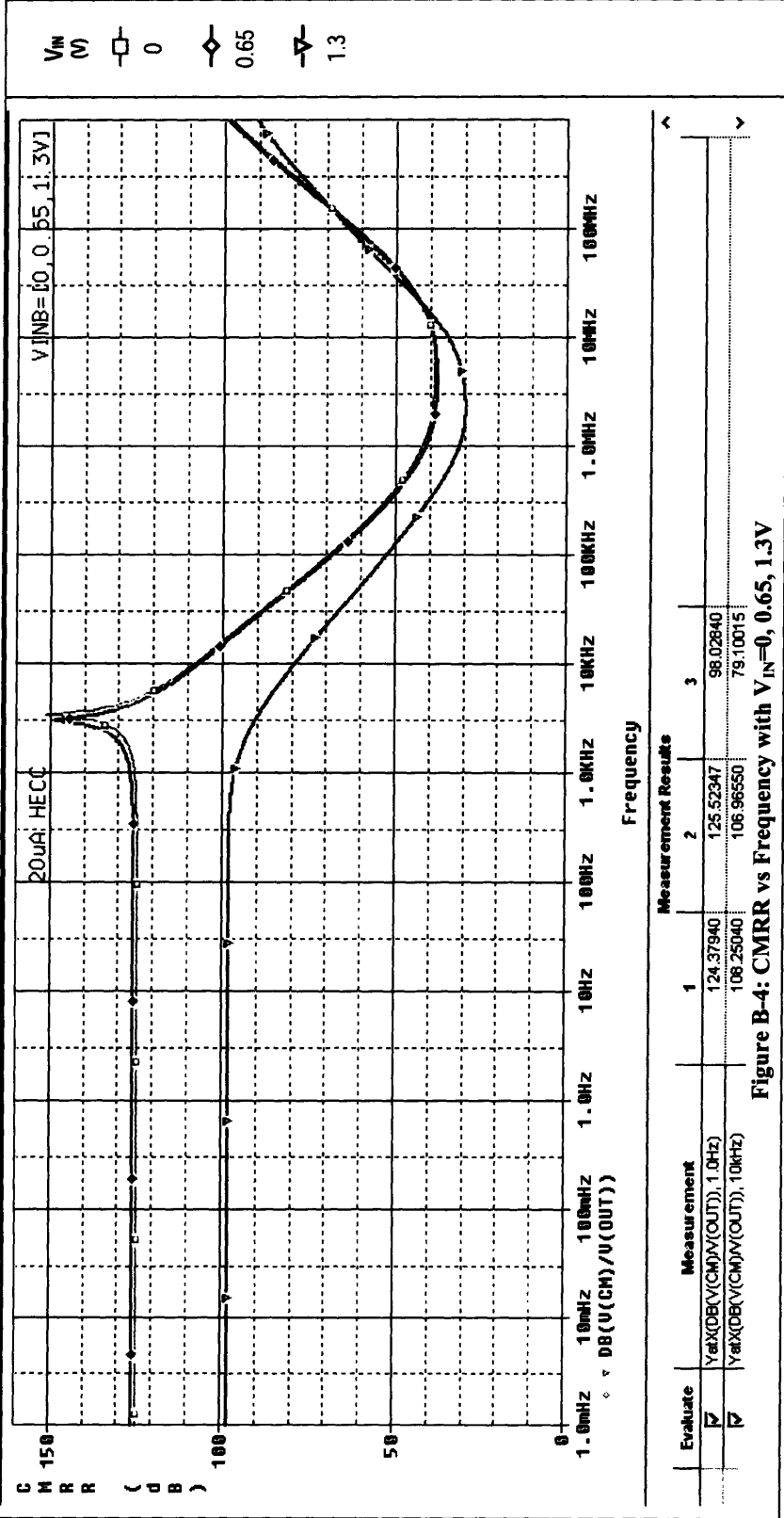

Figure B-4: CMRR vs Frequency with $V_{IN}=0, 0.65, 1.3V$

Evaluate	Measurement	1	2	3
<input checked="" type="checkbox"/>	Ymax(DB(V(CH)/V(OUT)), 10Hz)	124.37940	125.52347	98.02840
<input checked="" type="checkbox"/>	Ymax(DB(V(CH)/V(OUT)), 10kHz)	106.25040	106.96550	79.10015

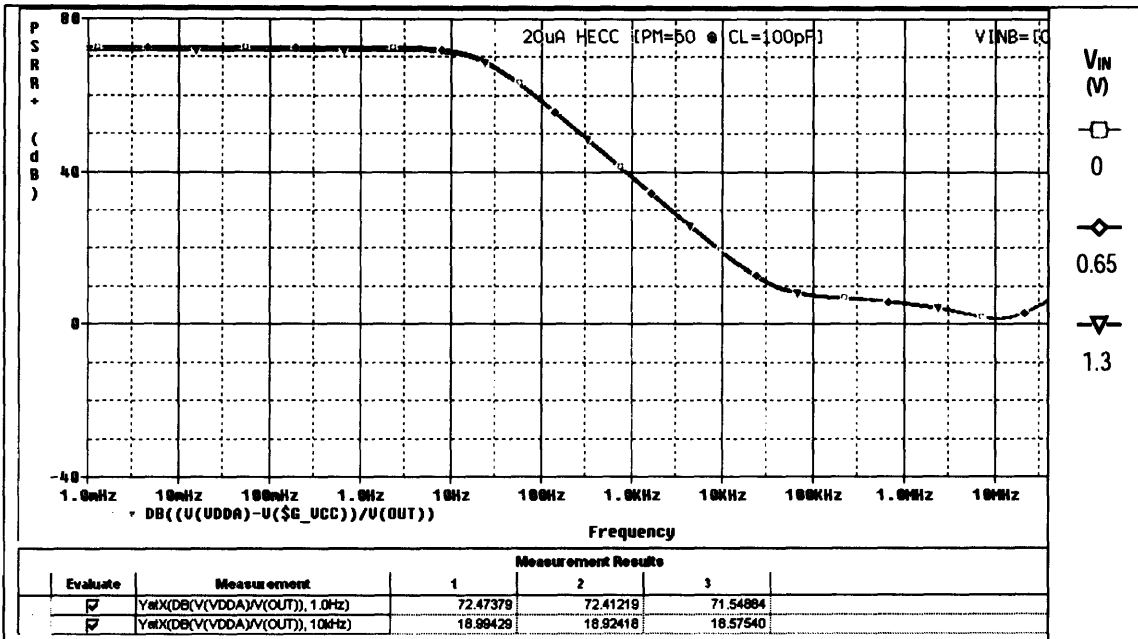

Figure B-5: PSRR+ vs Frequency with $V_{IN}=0, 0.65, 1.3V$

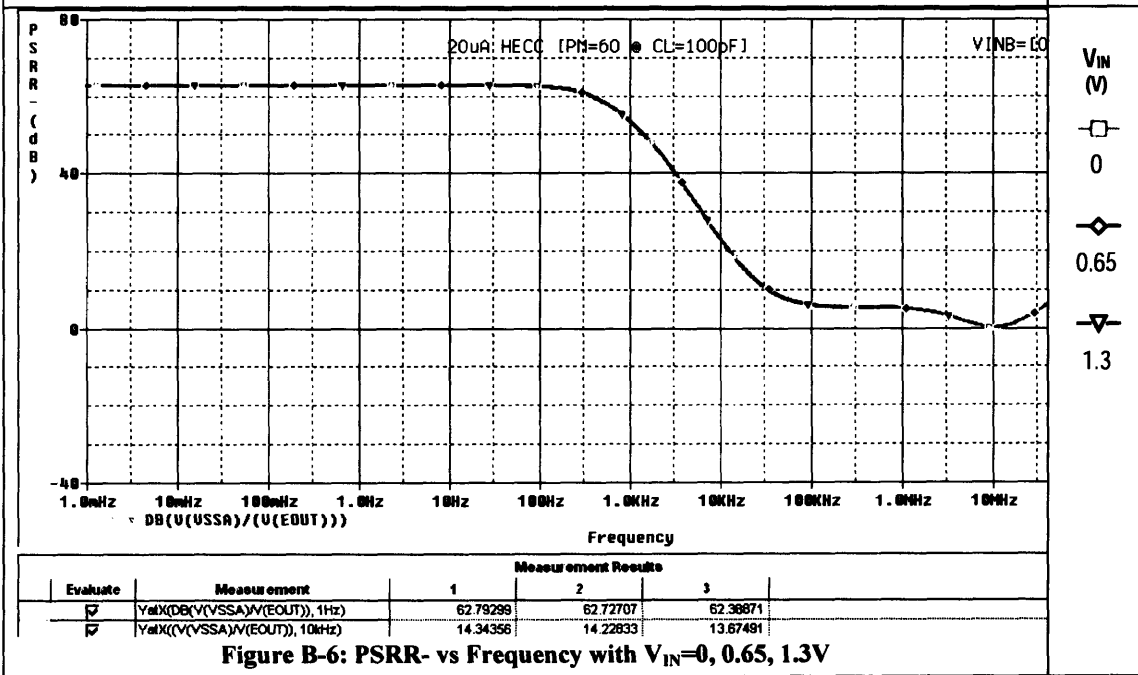
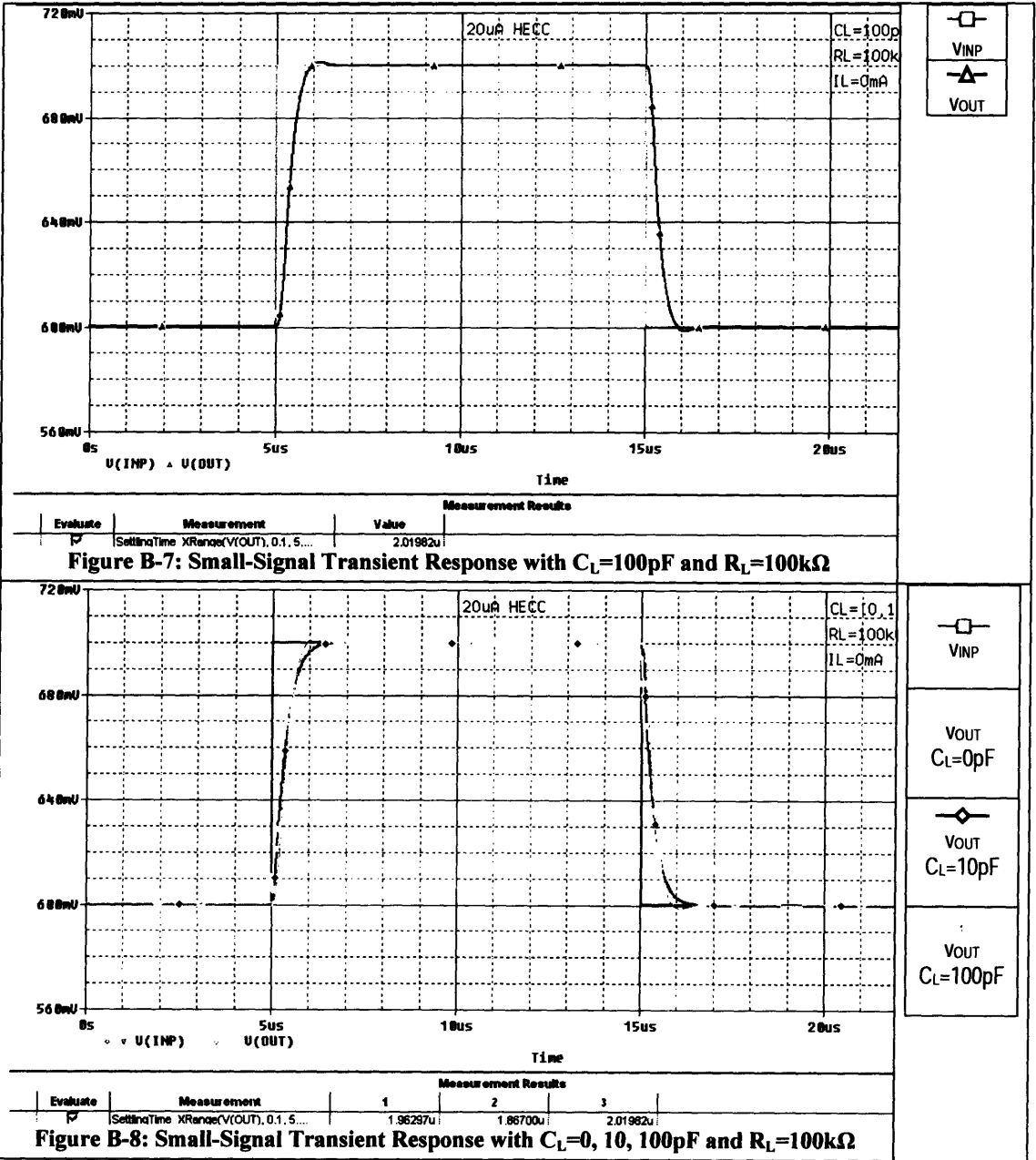

Figure B-6: PSRR- vs Frequency with $V_{IN}=0, 0.65, 1.3V$



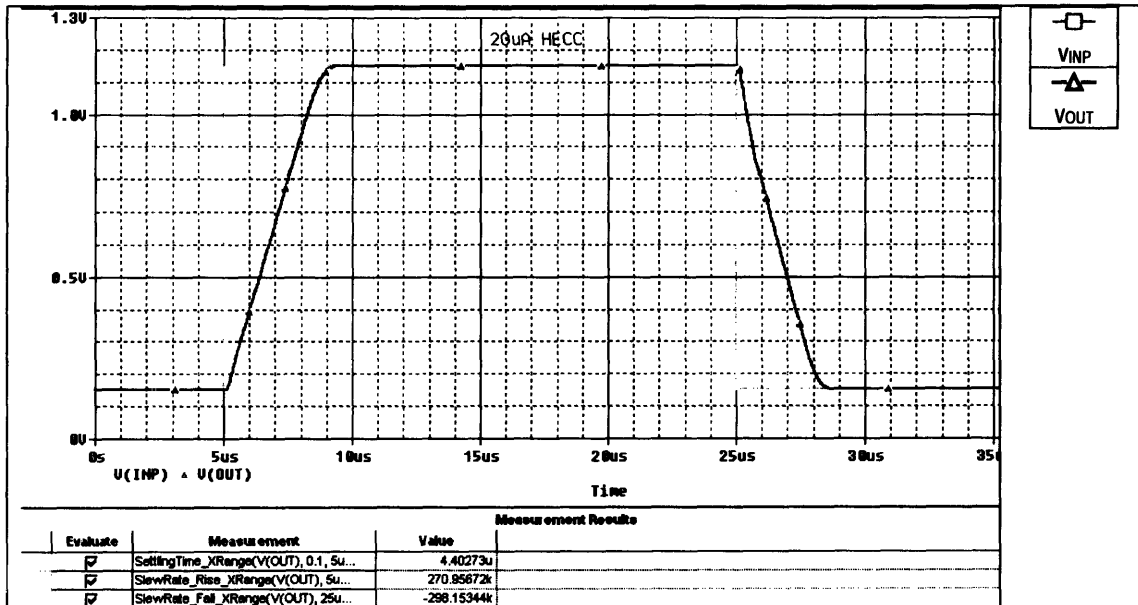

Figure B-9: Large-Signal Transient Response with $C_L=100\text{pF}$ and $R_L=100\text{k}\Omega$

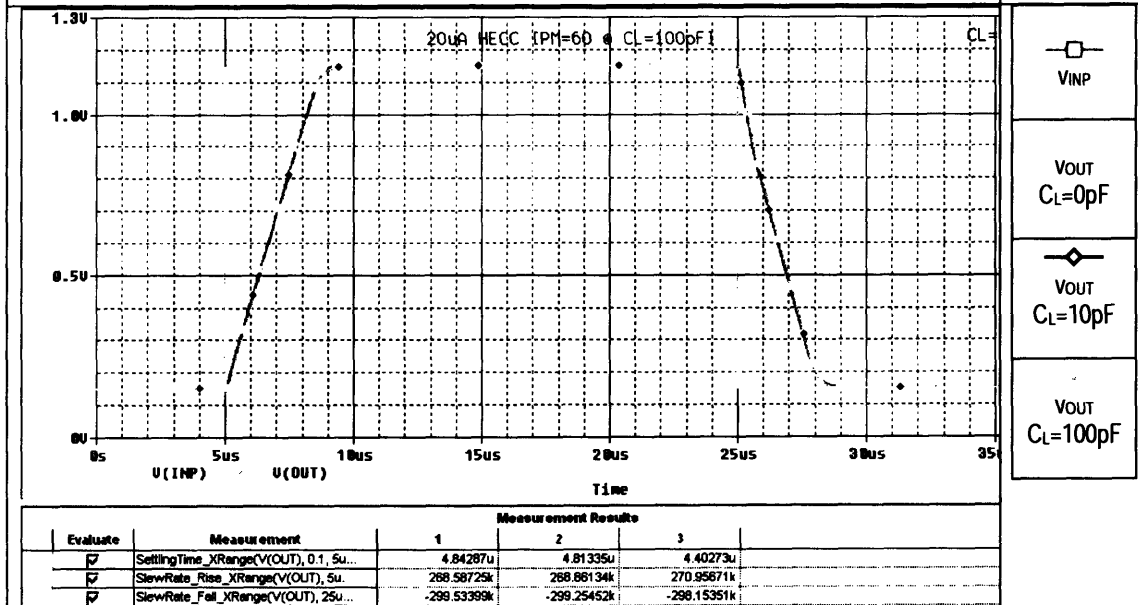
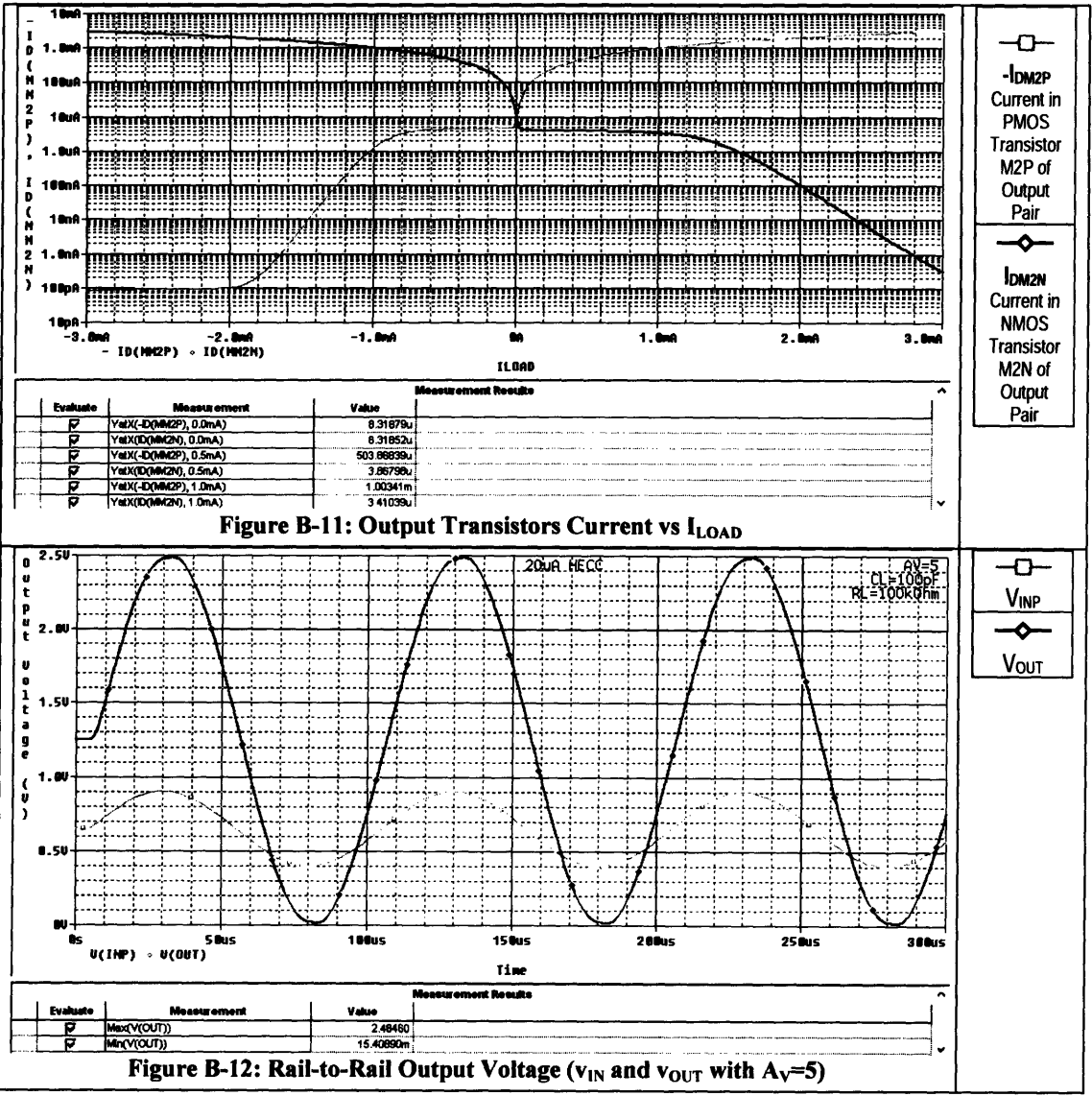

Figure B-10: Large-Signal Transient Response with $C_L=0, 10, 100\text{pF}$ and $R_L=100\text{k}\Omega$



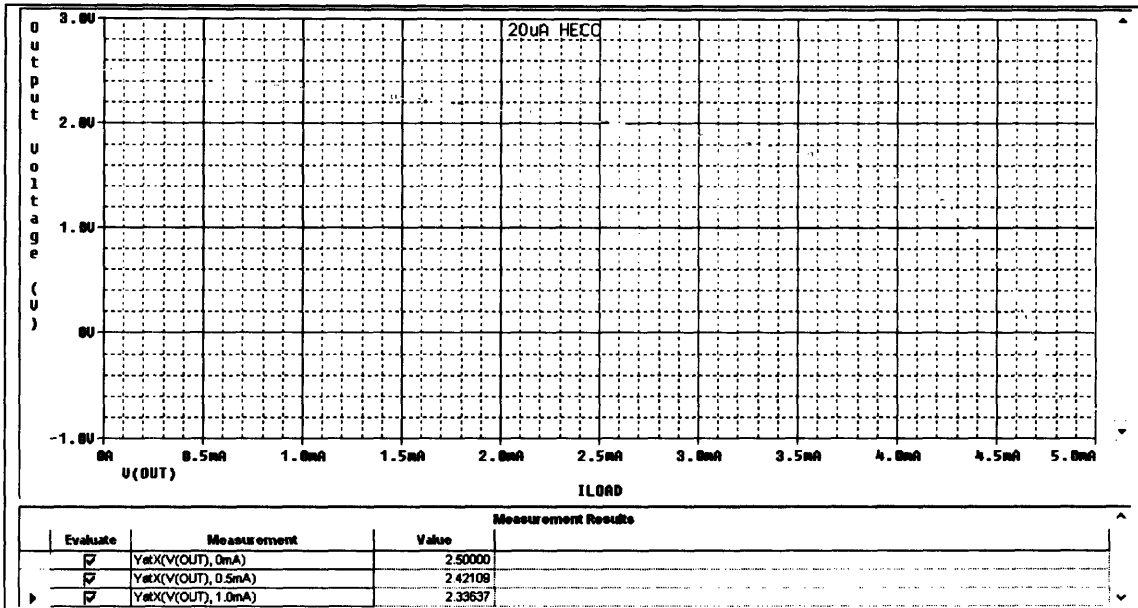

Figure B-13: Positive Output Voltage Swing vs I_{SOURCE}

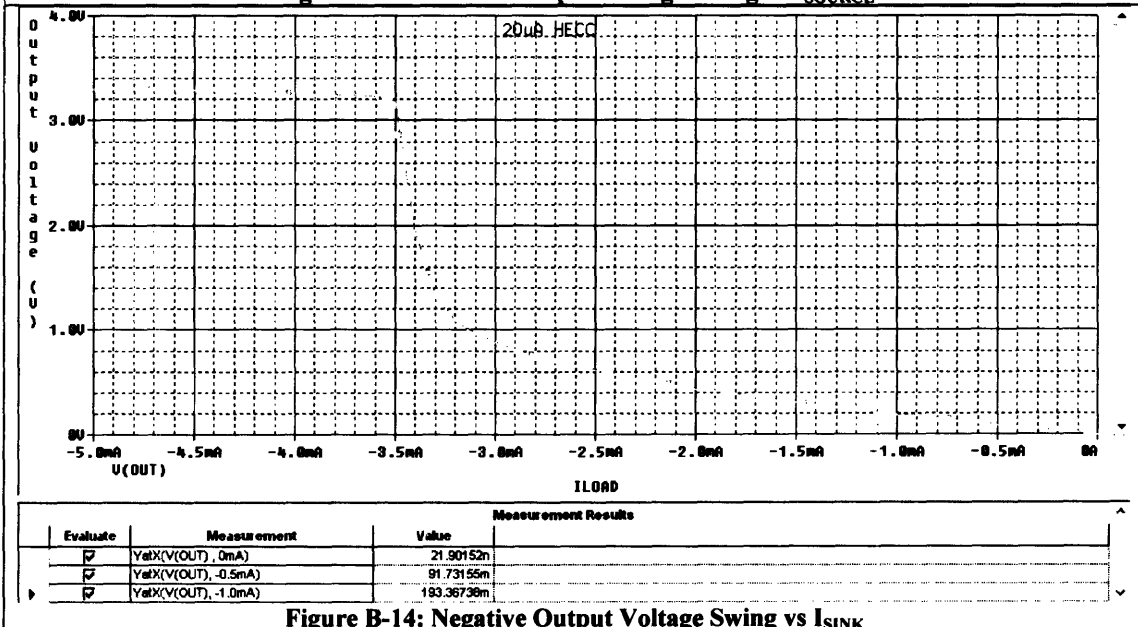

Figure B-14: Negative Output Voltage Swing vs I_{SINK}

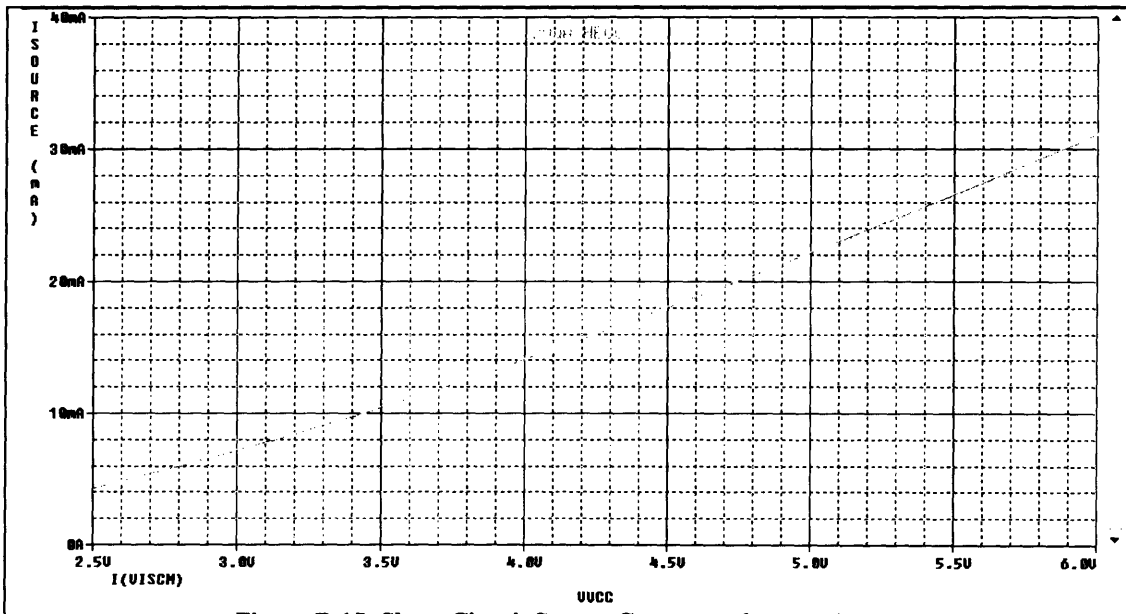

Figure B-15: Short-Circuit Source Current vs Supply Voltage

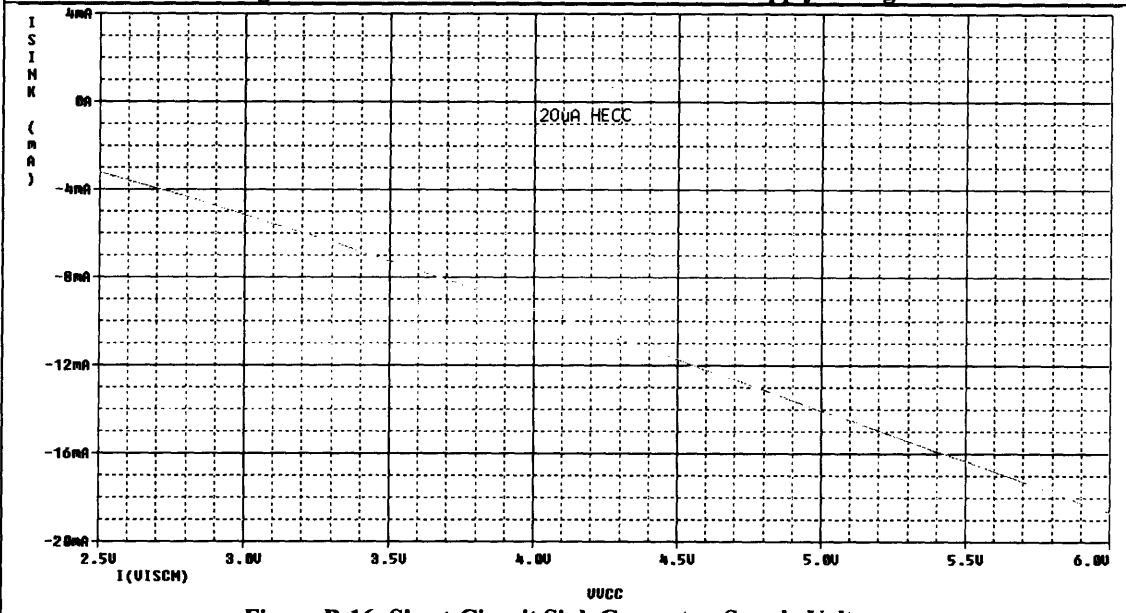
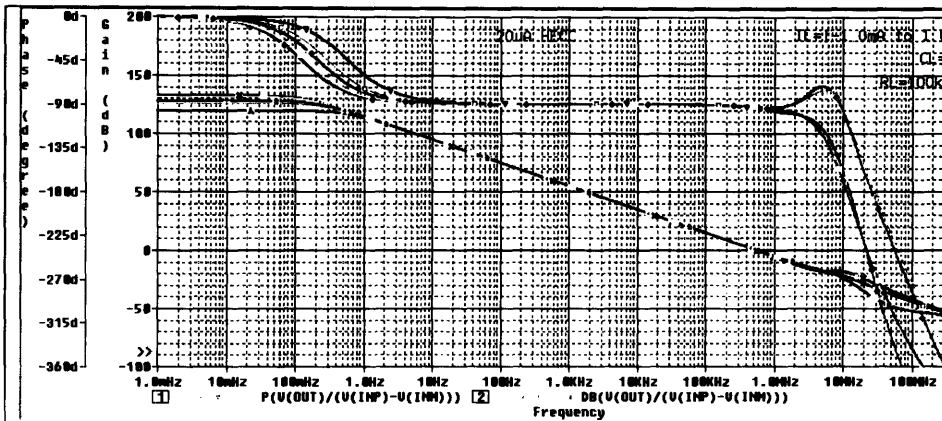
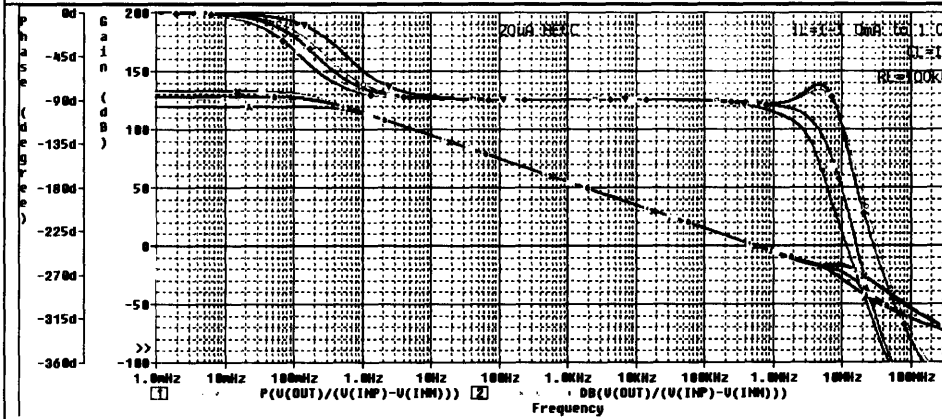

Figure B-16: Short-Circuit Sink Current vs Supply Voltage



Measurement Results						
Evaluate	Measurement	1	2	3	4	5
<input checked="" type="checkbox"/>	ZeroCross(DB(V(OUT)/V(INP)-V(NM...))	528.89464k	529.87237k	529.42157k	539.81927k	536.11439k
<input checked="" type="checkbox"/>	PhaseMargin(DB(V(OUT)/V(INP)-V(I...))	87.12035	87.18727	85.29589	86.78815	86.77688
<input checked="" type="checkbox"/>	GainMargin(P(V(OUT)/V(INP)-V(NM...))	26.81183	27.49626	24.51847	26.17053	26.26977
<input checked="" type="checkbox"/>	Peak(DB(V(OUT)/V(INP)-V(NM...)), 1)	<Evaluation Failed>	<Evaluation Failed>	<Evaluation Failed>	<Evaluation Failed>	<Evaluation Failed>

Figure B-17: Frequency Response with $C_L=0pF$ and $R_L=100k\Omega$ @ $I_L=-1.0, -0.5, 0.0, 0.5, 1.0mA$



Measurement Results						
Evaluate	Measurement	1	2	3	4	5
<input checked="" type="checkbox"/>	ZeroCross(DB(V(OUT)/V(INP)-V(NM...))	529.23750k	530.24913k	531.57973k	540.22721k	536.42829k
<input checked="" type="checkbox"/>	PhaseMargin(DB(V(OUT)/V(INP)-V(I...))	86.84758	86.95542	82.88383	86.52458	86.58145
<input checked="" type="checkbox"/>	GainMargin(P(V(OUT)/V(INP)-V(NM...))	24.93064	22.37302	21.11787	22.67337	23.48443
<input checked="" type="checkbox"/>	Peak(DB(V(OUT)/V(INP)-V(NM...)), 1)	<Evaluation Failed>	-18.83024	<Evaluation Failed>	<Evaluation Failed>	<Evaluation Failed>

Figure B-18: Frequency Response with $C_L=10pF$ and $R_L=100k\Omega$ @ $I_L=-1.0, -0.5, 0.0, 0.5, 1.0mA$

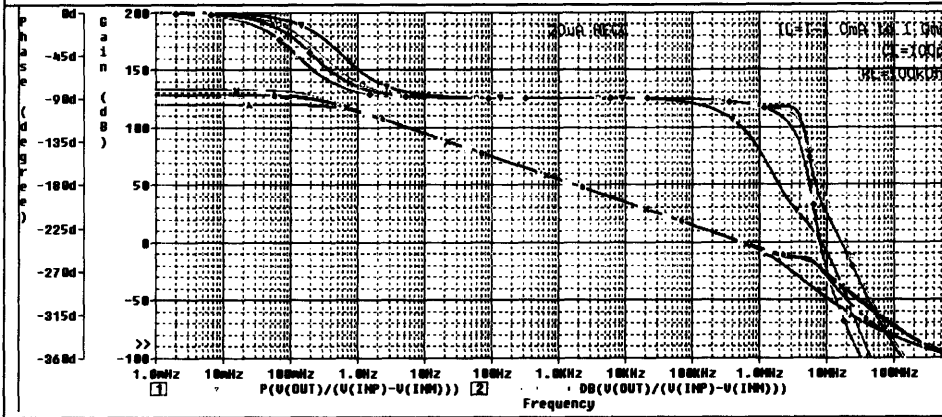

Measurement Results						
Evaluate	Measurement	1	2	3	4	5
<input checked="" type="checkbox"/>	ZeroCross(DB(V(OUT)/V(INP)-V(NM...))	531.84333k	533.31947k	507.07923k	543.52150k	541.02001k
<input checked="" type="checkbox"/>	PhaseMargin(DB(V(OUT)/V(INP)-V(I...))	84.38584	84.84181	81.19486	84.30372	84.80843
<input checked="" type="checkbox"/>	GainMargin(P(V(OUT)/V(INP)-V(NM...))	24.38642	19.28623	17.21973	14.98323	15.94021
<input checked="" type="checkbox"/>	Peak(DB(V(OUT)/V(INP)-V(NM...)), 1)	<Evaluation Failed>	-14.01218	<Evaluation Failed>	<Evaluation Failed>	<Evaluation Failed>

Figure B-19: Frequency Response with $C_L=100pF$ and $R_L=100k\Omega$ @ $I_L=-1.0, -0.5, 0.0, 0.5, 1.0mA$

I_L (mA)	Symbol
-1.0	Phase Gain
-0.5	Phase Gain
0.0	Phase Gain
0.5	Phase Gain
1.0	Phase Gain

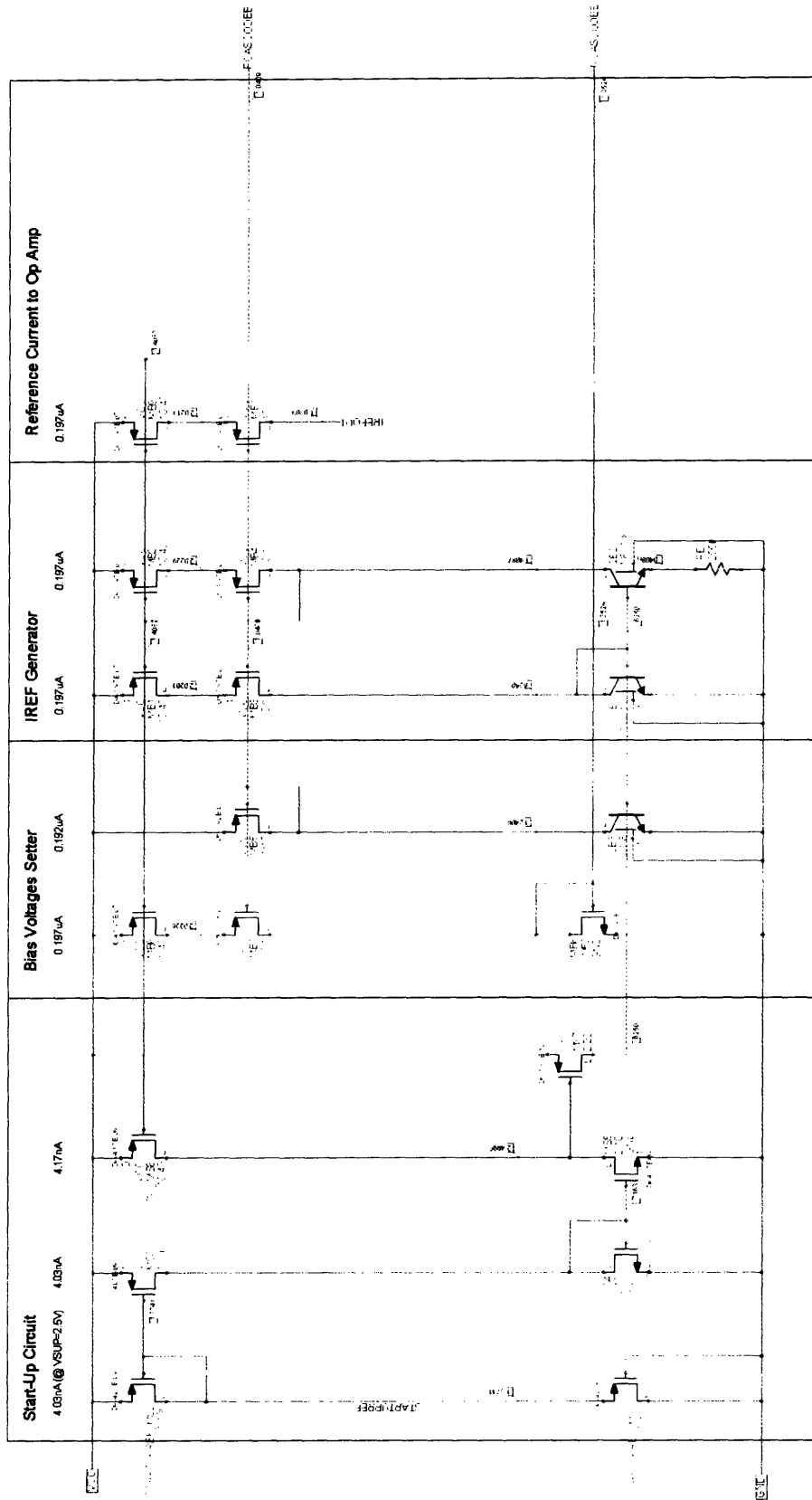

Figure B-20: Schematic of Bias Cell for 20µA Micropower Op Amp with Hybrid Explicit Cascode Compensation (HECC)

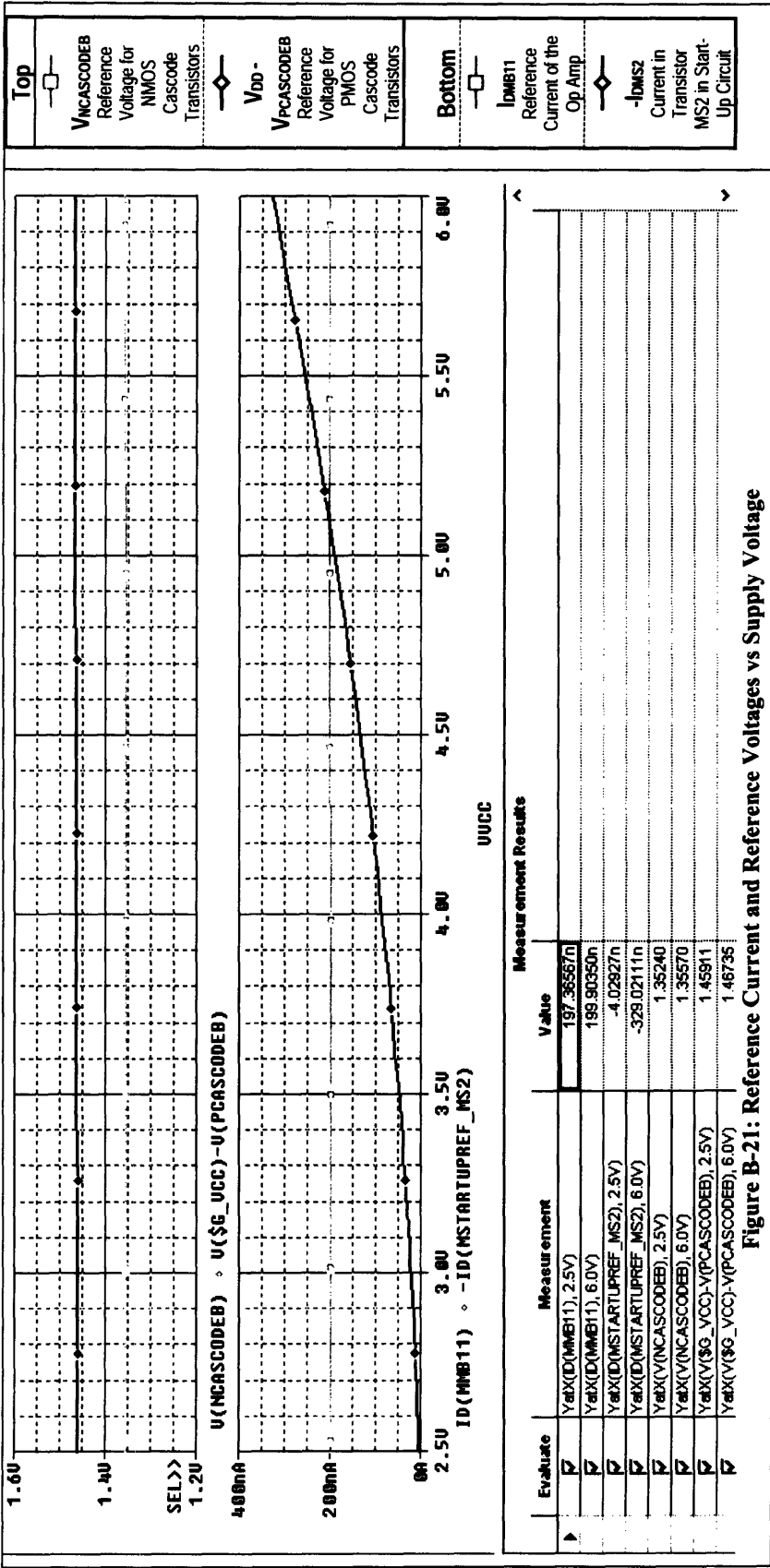

Figure B-21: Reference Current and Reference Voltages vs Supply Voltage

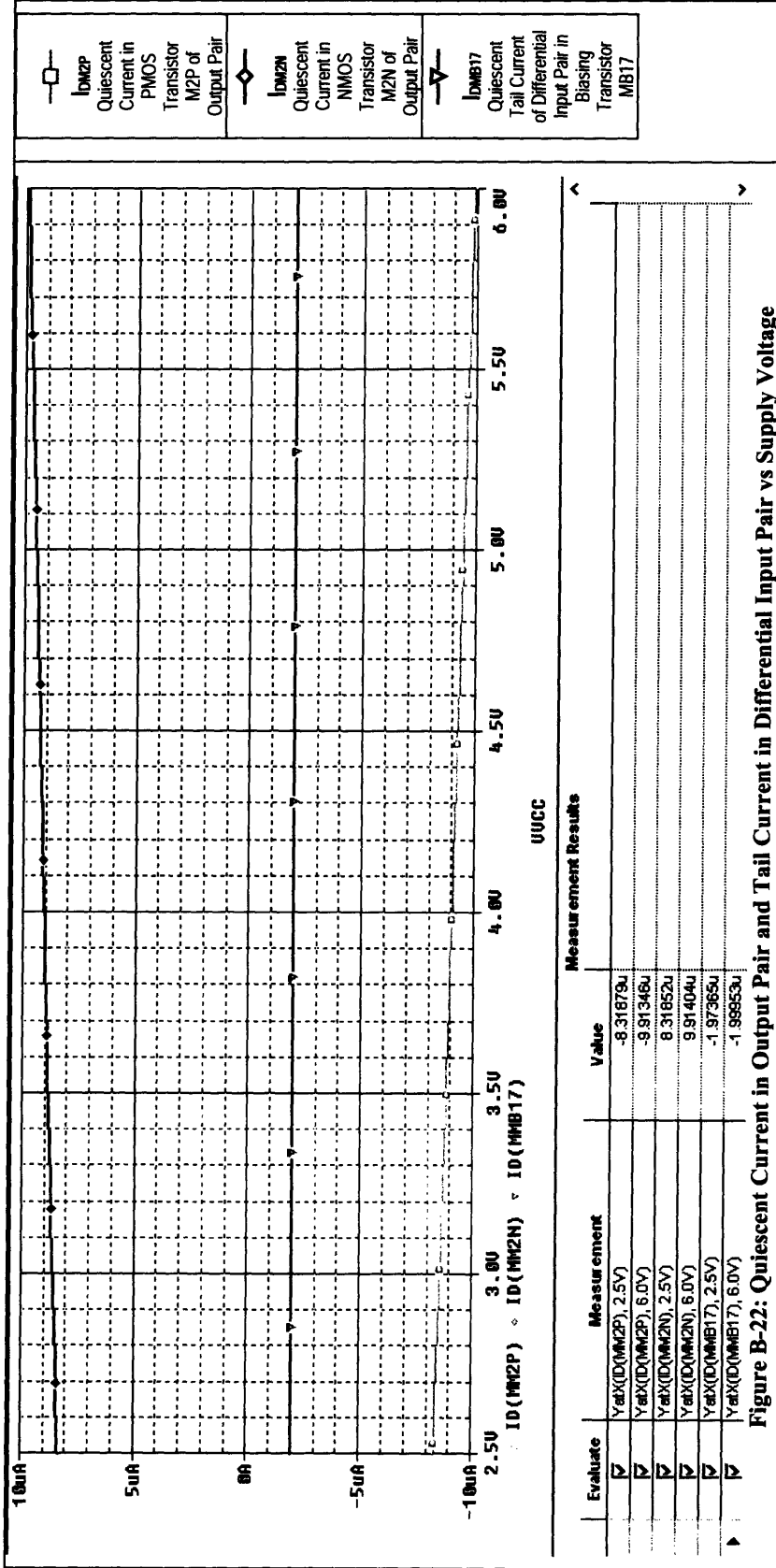

Figure B-22: Quiescent Current in Output Pair and Tail Current in Differential Input Pair vs Supply Voltage

Appendix C Schematics and Characteristics of 20 μ A Micropower Op Amp with Hybrid Symmetric Embedded Cascode Compensation (HSECC)

LIST OF FIGURES IN APPENDIX C

Table C: Characteristics of 20 μ A Micropower Op Amp with Hybrid Symmetric Embedded Compensation (HSECC) from Simulation.....	115
Figure C-1: Schematic of 20 μ A Micropower Op Amp with Hybrid Symmetric Embedded Cascode Compensation (HSECC)	117
Figure C-2: Frequency Response with $C_L=100\text{pF}$ and $R_L=100\text{k}\Omega$	118
Figure C-3: Frequency Response with $C_L=0, 10, 100, 200, 500\text{pF}$ and $R_L=100\text{k}\Omega$	119
Figure C-4: CMRR vs Frequency with $V_{IN}=0, 0.65, 1.3\text{V}$	120
Figure C-5: PSRR+ vs Frequency with $V_{IN}=0, 0.65, 1.3\text{V}$	121
Figure C-6: PSRR- vs Frequency with $V_{IN}=0, 0.65, 1.3\text{V}$	121
Figure C-7: Small-Signal Transient Response with $C_L=100\text{pF}$ and $R_L=100\text{k}\Omega$	122
Figure C-8: Small-Signal Transient Response with $C_L=0, 10, 100\text{pF}$ and $R_L=100\text{k}\Omega$..	122
Figure C-9: Large-Signal Transient Response with $C_L=100\text{pF}$ and $R_L=100\text{k}\Omega$	123
Figure C-10: Large-Signal Transient Response with $C_L=0, 10, 100\text{pF}$ and $R_L=100\text{k}\Omega$	123
Figure C-11: Output Transistors Current vs I_{LOAD}	124
Figure C-12: Rail-to-Rail Output Voltage (v_{IN} and v_{OUT} with $A_V=5$)	124
Figure C-13: Positive Output Voltage Swing vs I_{SOURCE}	125
Figure C-14: Negative Output Voltage Swing vs I_{SINK}	125
Figure C-15: Short-Circuit Source Current vs Supply Voltage.....	126
Figure C-16: Short-Circuit Sink Current vs Supply Voltage.....	126

Figure C-17: Frequency Response with $C_L=0\text{pF}$ and $R_L=100\text{k}\Omega$ @ $I_L=-1.0, -0.5, 0.0, 0.5, 1.0\text{mA}$	127
Figure C-18: Frequency Response with $C_L=10\text{pF}$ and $R_L=100\text{k}\Omega$ @ $I_L=-1.0, -0.5, 0.0, 0.5, 1.0\text{mA}$	127
Figure C-19: Frequency Response with $C_L=100\text{pF}$ and $R_L=100\text{k}\Omega$ @ $I_L=-1.0, -0.5, 0.0, 0.5, 1.0\text{mA}$	127
Figure C-20: Schematic of Bias Cell for $20\mu\text{A}$ Micropower Op Amp with Hybrid Symmetric Embedded Cascode Compensation (HSECC).....	128
Figure C-21: Reference Current and Reference Voltages vs Supply Voltage.....	129
Figure C-22: Quiescent Current in Output Pair and Tail Current in Differential Input Pair vs Supply Voltage.....	130

Table C: Characteristics of 20 μ A Micropower Op Amp with Hybrid Symmetric Embedded Compensation (HSECC) from Simulation

Simulation results are at 25°C. $V_{DD} = 2.5V$ and $V_{SS} = 0V$.					
Primary Characteristics					
Symbol	Parameter	Condition	Value		Unit
			Specified	Simulated	
GBW ²²	Gain Bandwidth Product	$C_L = 100pF$ $R_L = 100k\Omega$	> 0.3	0.617 ($\Phi_M = 60.6^\circ$)	MHz
A_{VOL}	Large-Signal Voltage Gain (DC Open-Loop Gain)	$C_L = 100pF$ $R_L = 100k\Omega$	> 100	123	dB
I_S	Supply Current	No Load	< 21	19.43	μA
V_{INCM}^{23}	Input Common-Mode Range	-	> $V_{DD} - 1.25V$ and must include negative supply voltage	1.3 and includes negative supply voltage	V
V_{OS}^{24}	(Untrimmed) Input Offset Voltage	$V_{INCM} = 0.65V$	< 5	4.17	mV
V_{OUT}	V_{OUTH}	High Output Voltage $I_{SOURCE} = 1.0mA$	> $V_{DD} - 0.3V$	2.34	V
	V_{OUTL}	Low Output Voltage $I_{SINK} = 1.0mA$	< $V_{SS} + 0.3V$	0.19	V
I_{SOURCE}^{25}	Output Source Current	$C_L = 100pF$ $R_L = 100k\Omega$	> 1.0	1.55	mA
I_{SINK}	Output Sink Current	$C_L = 100pF$ $R_L = 100k\Omega$	> 1.0	1.04	mA
Secondary Characteristics					
Symbol	Parameter	Condition	Value		Unit
			Specified	Simulated	
SR+	Positive Going Slew Rate	$A_V = 1V/V, 1V$ Step	> 0.15	0.254	V/ μs
SR-	Negative Going Slew Rate	$A_V = 1V/V, 1V$ Step	< -0.15	-0.269	V/ μs

²² Gain bandwidth product per supply current $GBW/I_S = 31.8MHz/mA @ C_L = 100pF$.

²³ Verified by CMRR simulation in Figure C-4.

²⁴ Conservative estimate from calculation.

²⁵ Maximum output source current is measured when the other transistor in the output pair starts to turn off, i.e. its current goes down to as low as $1\mu A$.

CMRR	Common Mode Rejection Ratio	@ DC	> 60	147	dB
PSRR+	Positive Power Supply Rejection Ratio	@ DC	> 60	88.4	dB
PSRR-	Negative Power Supply Rejection Ratio	@ DC	> 60	103	dB
t_s	0.1% Settling Time	$A_v = 1V/V, 1V$ Step	< 10	$12 < t_s < 20$	μs

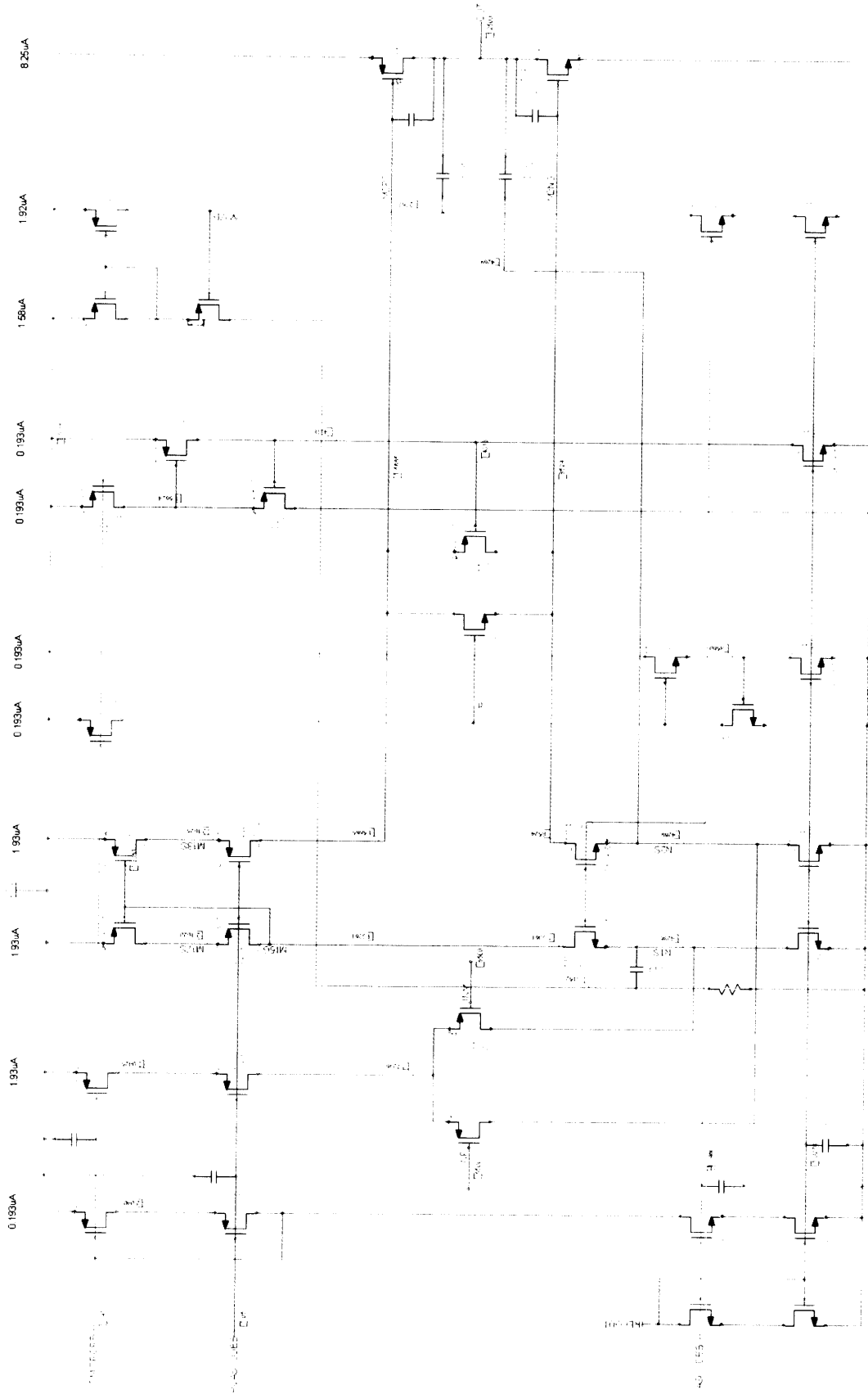
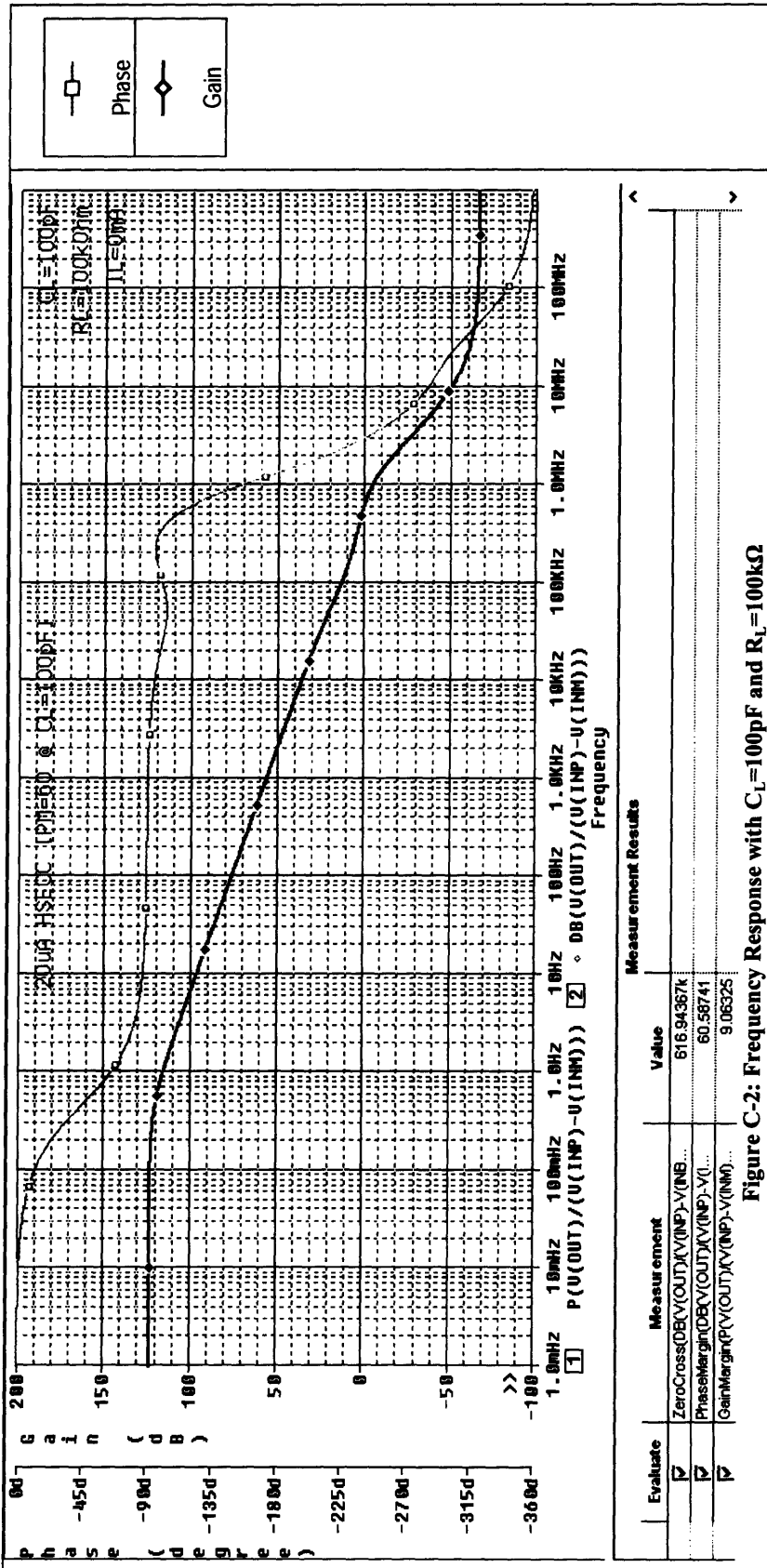
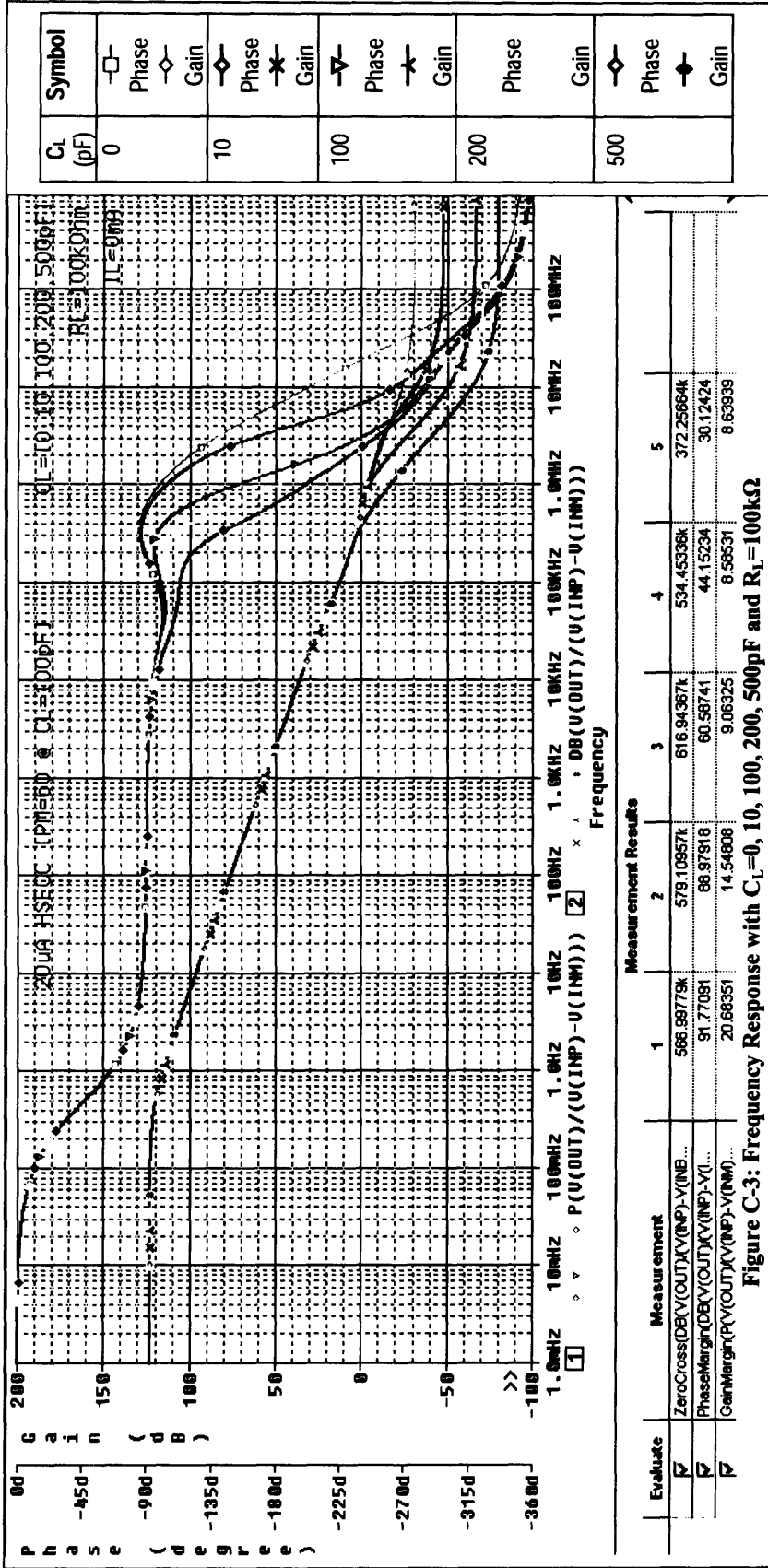
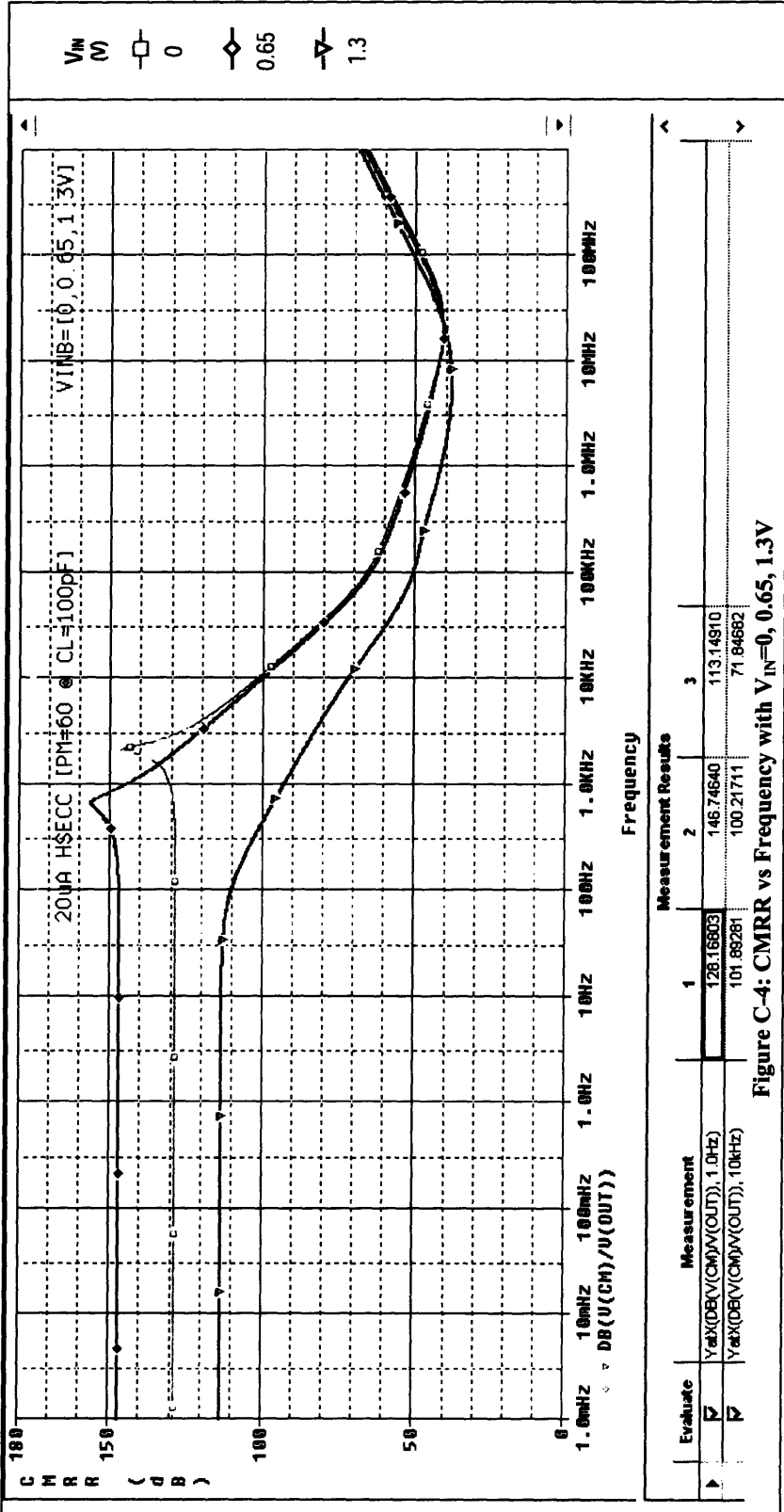

Figure C-1: Schematic of 20µA Micropower Op Amp with Hybrid Symmetric Embedded Cascade Compensation (HSECC)







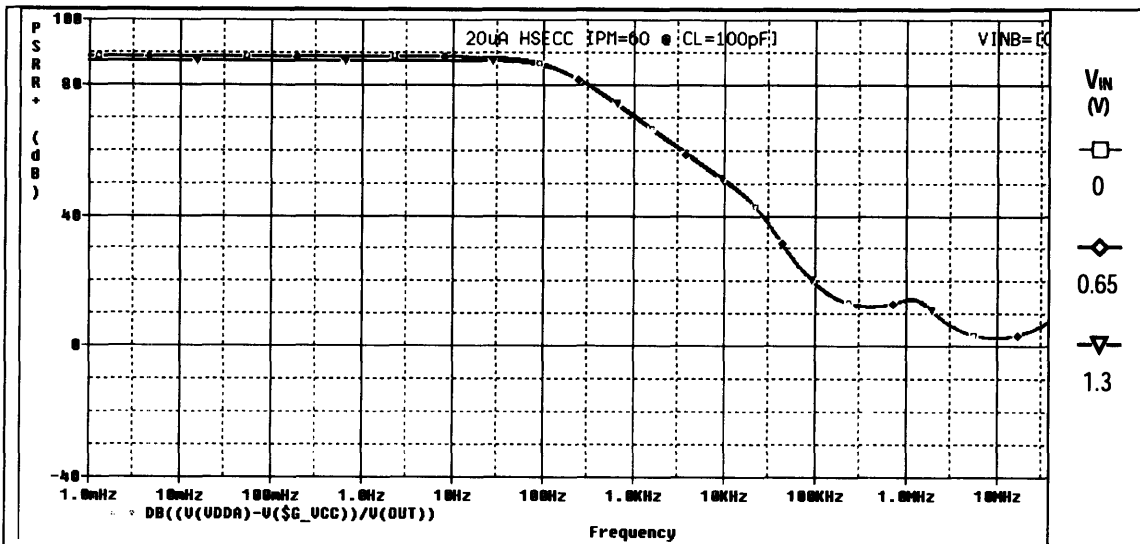

Figure C-5: PSRR+ vs Frequency with $V_{IN}=0, 0.65, 1.3V$

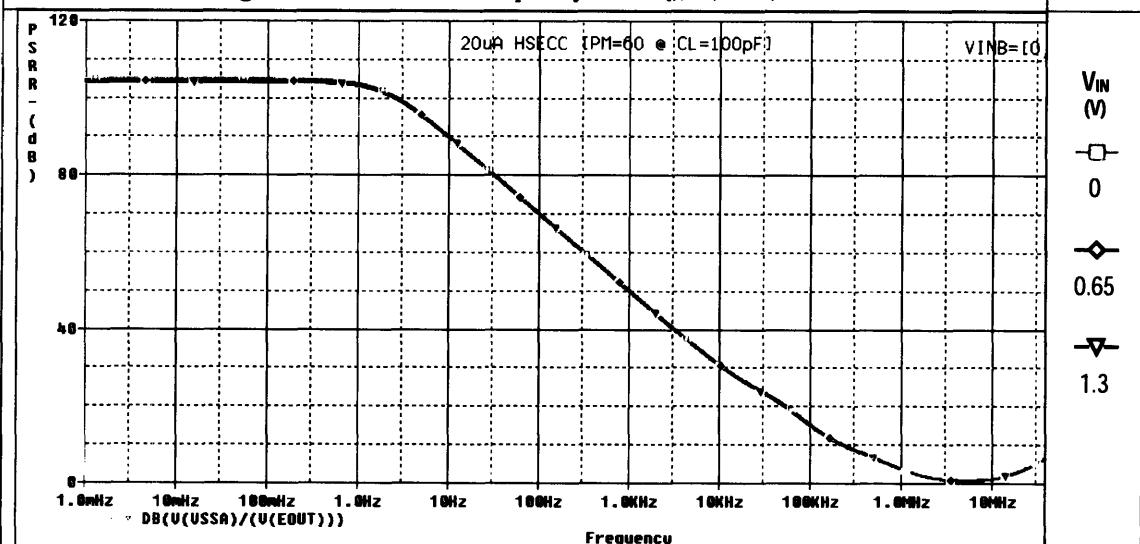

Figure C-6: PSRR- vs Frequency with $V_{IN}=0, 0.65, 1.3V$

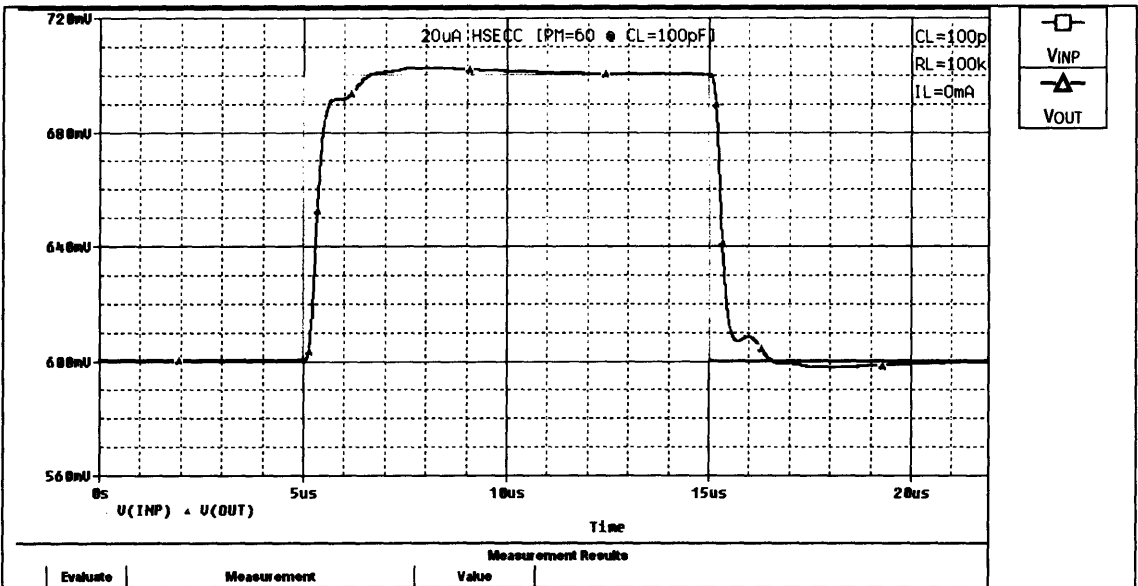

Figure C-7: Small-Signal Transient Response with $C_L=100\text{pF}$ and $R_L=100\text{k}\Omega$

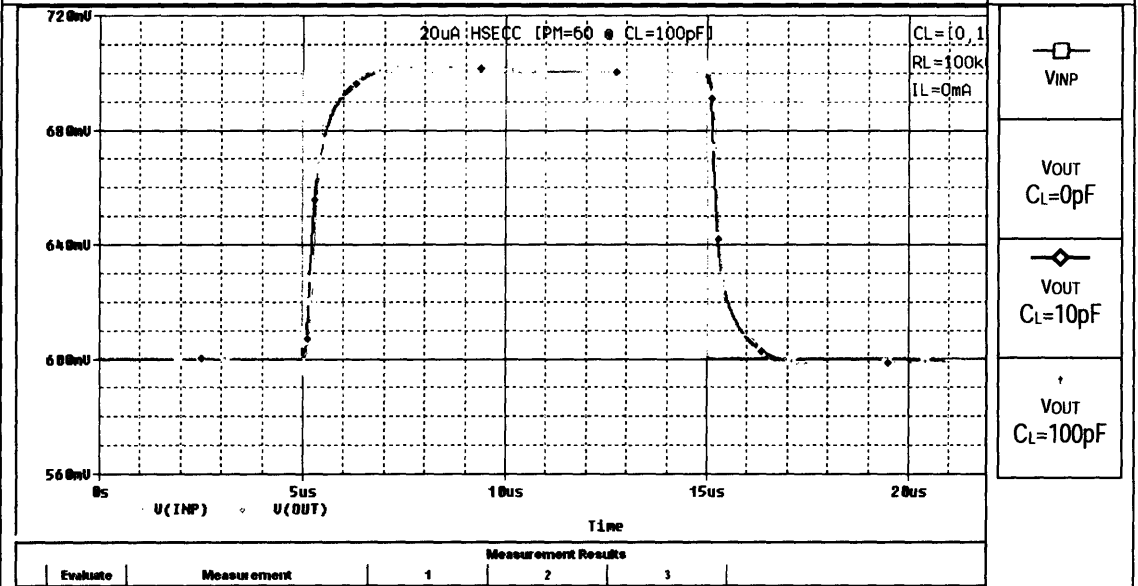

Figure C-8: Small-Signal Transient Response with $C_L=0, 10, 100\text{pF}$ and $R_L=100\text{k}\Omega$

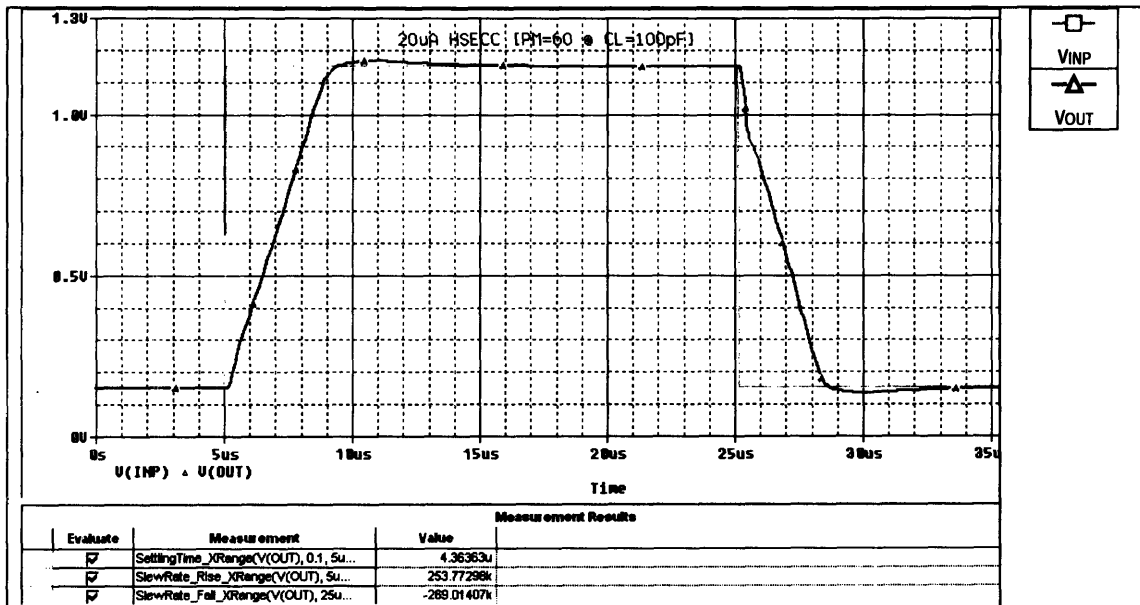

Figure C-9: Large-Signal Transient Response with $C_L=100\text{pF}$ and $R_L=100\text{k}\Omega$

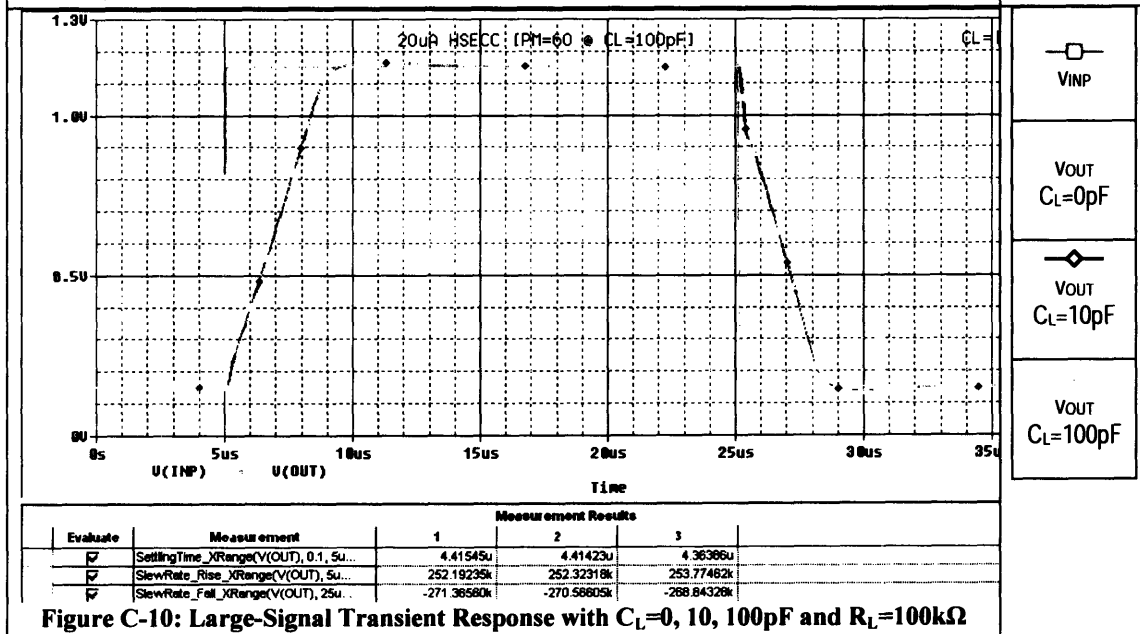
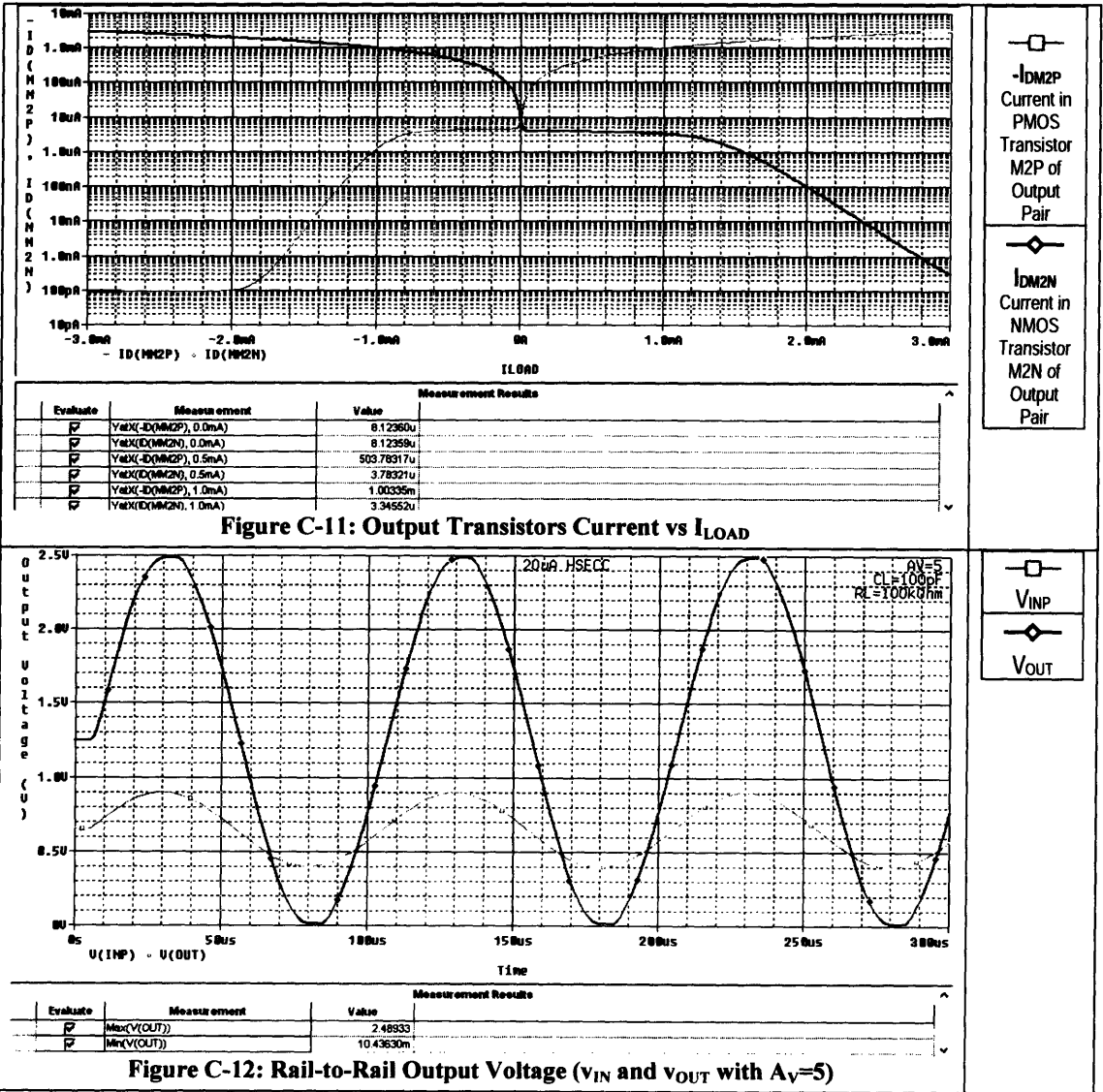

Figure C-10: Large-Signal Transient Response with $C_L=0, 10, 100\text{pF}$ and $R_L=100\text{k}\Omega$



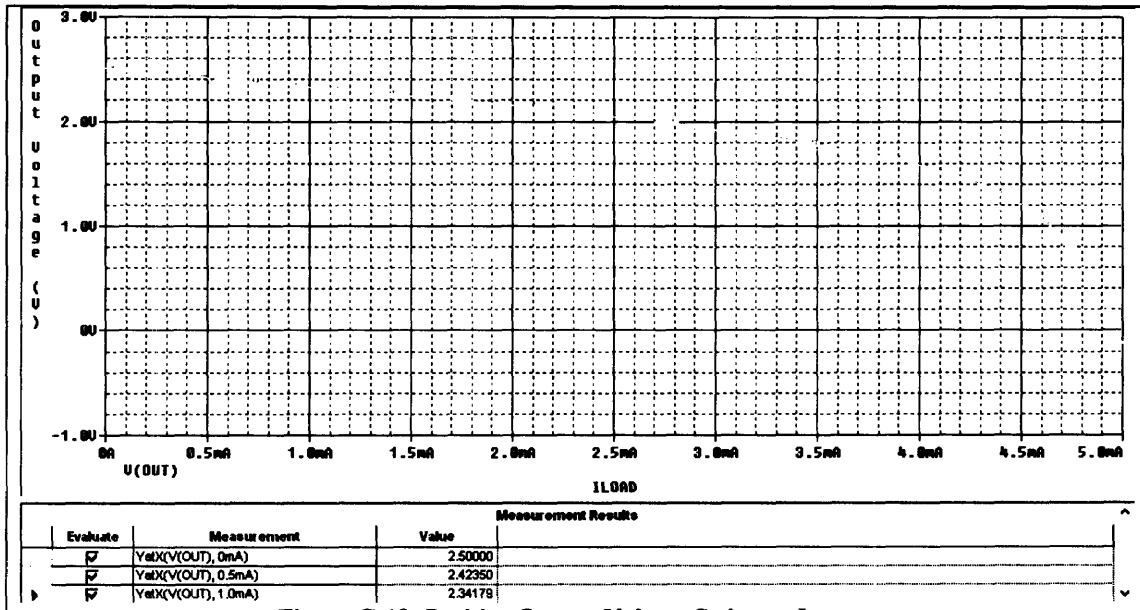

Figure C-13: Positive Output Voltage Swing vs I_{SOURCE}

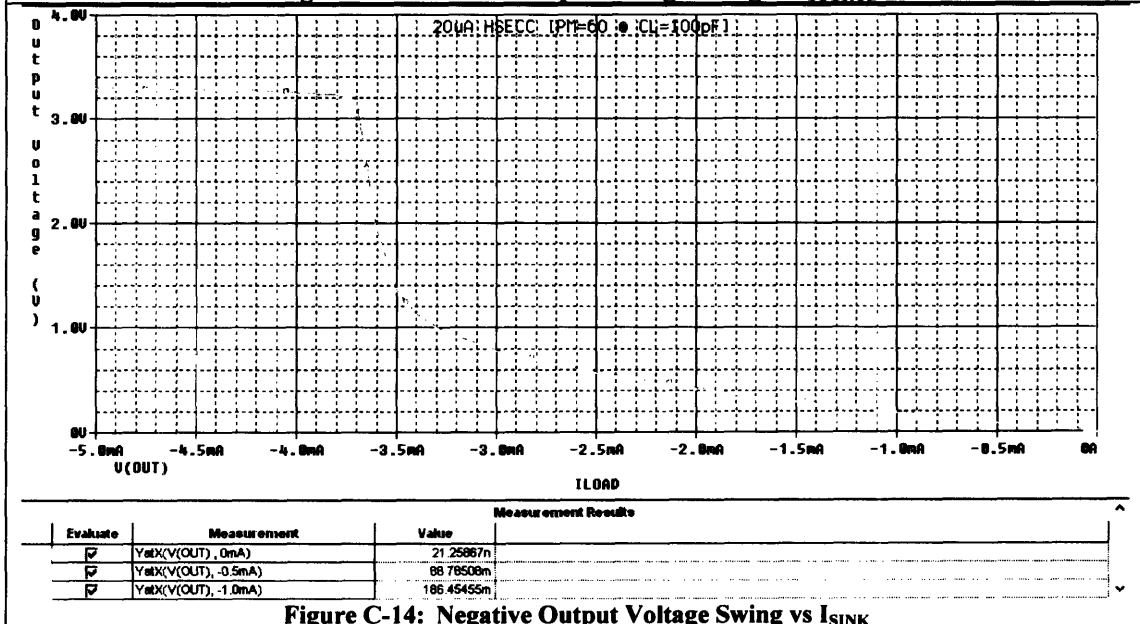

Figure C-14: Negative Output Voltage Swing vs I_{SINK}

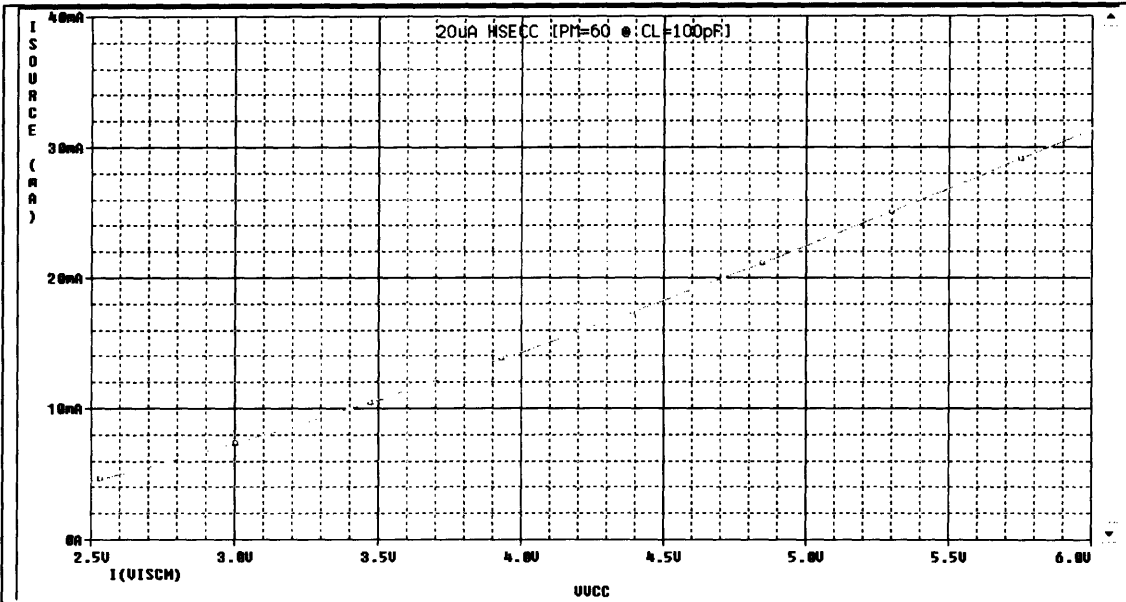

Figure C-15: Short-Circuit Source Current vs Supply Voltage

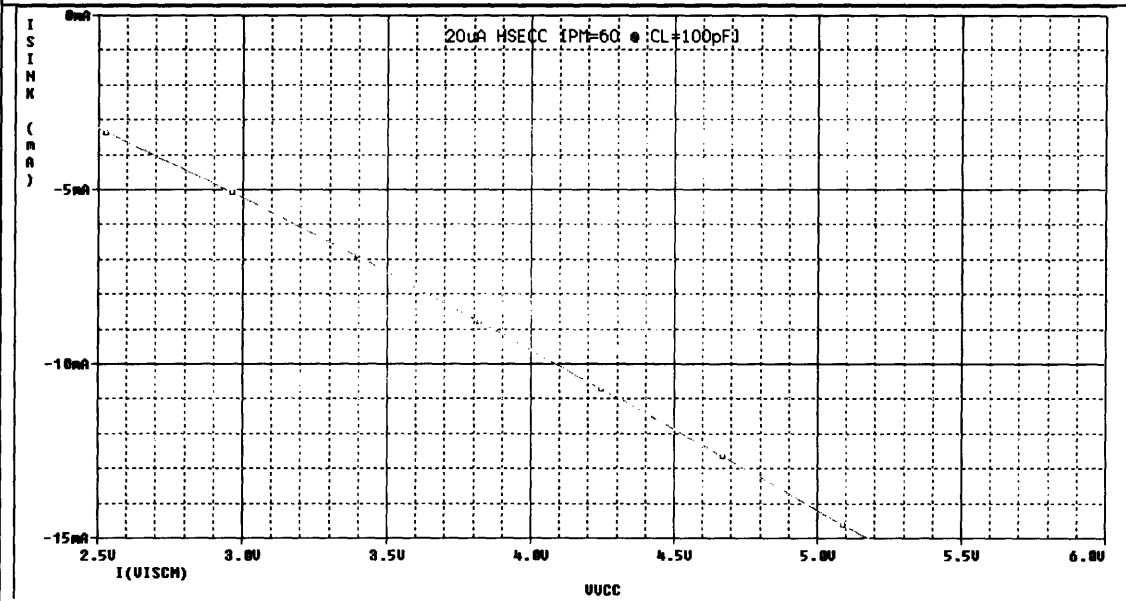

Figure C-16: Short-Circuit Sink Current vs Supply Voltage

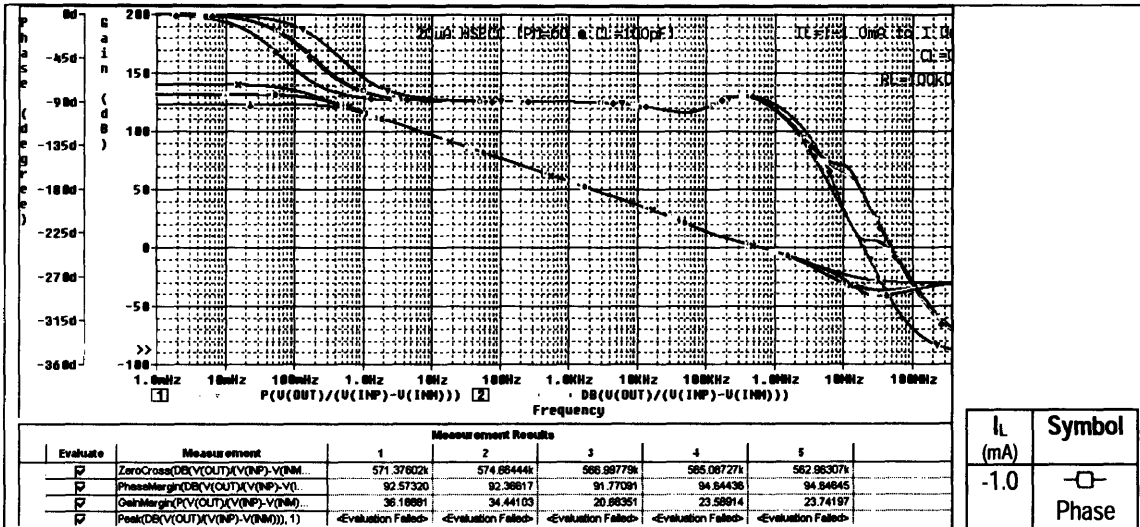

Figure C-17: Frequency Response with $C_L=0pF$ and $R_L=100k\Omega$ @ $I_L=-1.0, -0.5, 0.0, 0.5, 1.0mA$

I_L (mA)	Symbol
-1.0	Phase Gain
-0.5	Phase Gain
0.0	Phase Gain
0.5	Phase Gain
1.0	Phase Gain

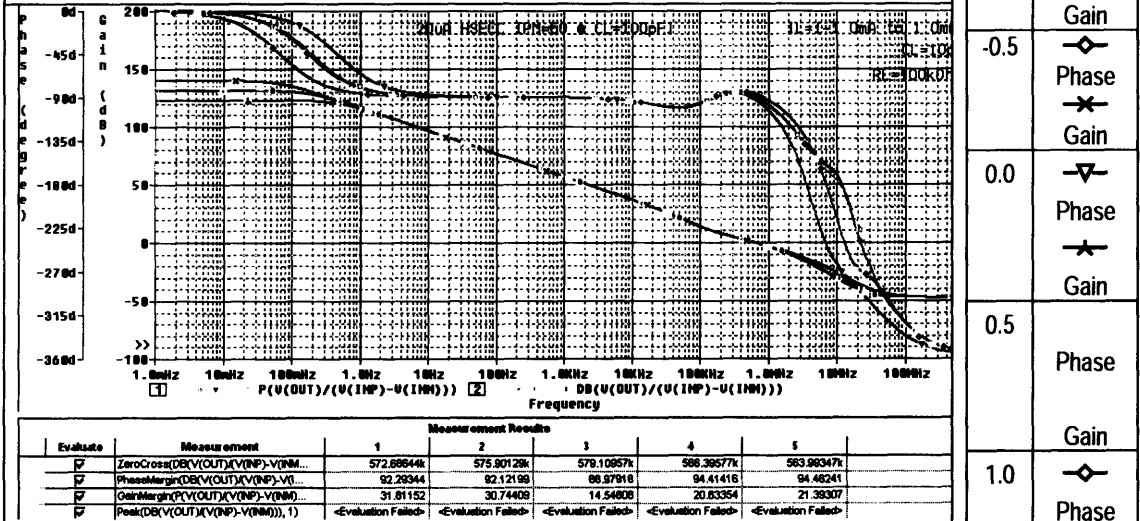

Figure C-18: Frequency Response with $C_L=10pF$ and $R_L=100k\Omega$ @ $I_L=-1.0, -0.5, 0.0, 0.5, 1.0mA$

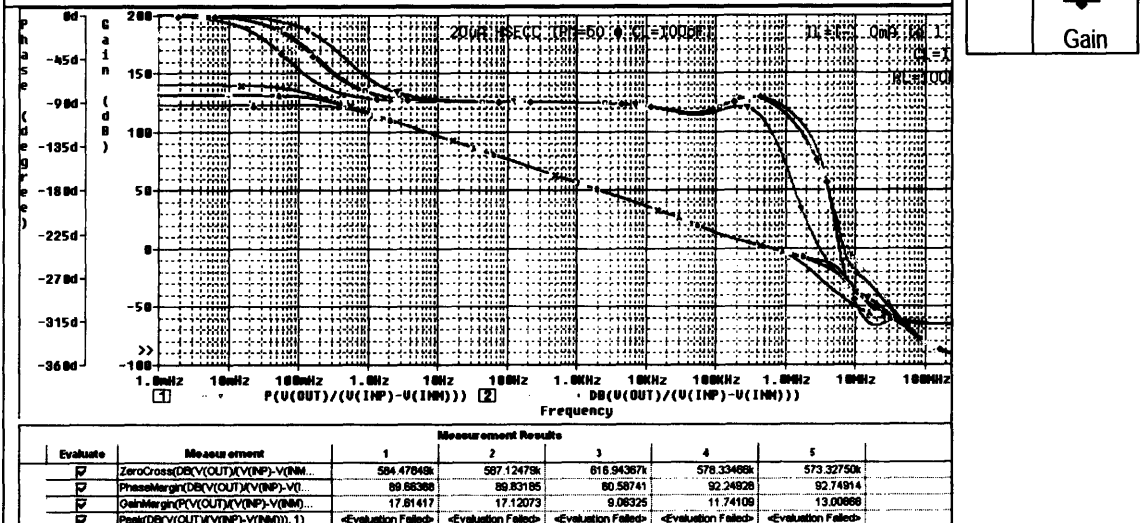

Figure C-19: Frequency Response with $C_L=100pF$ and $R_L=100k\Omega$ @ $I_L=-1.0, -0.5, 0.0, 0.5, 1.0mA$

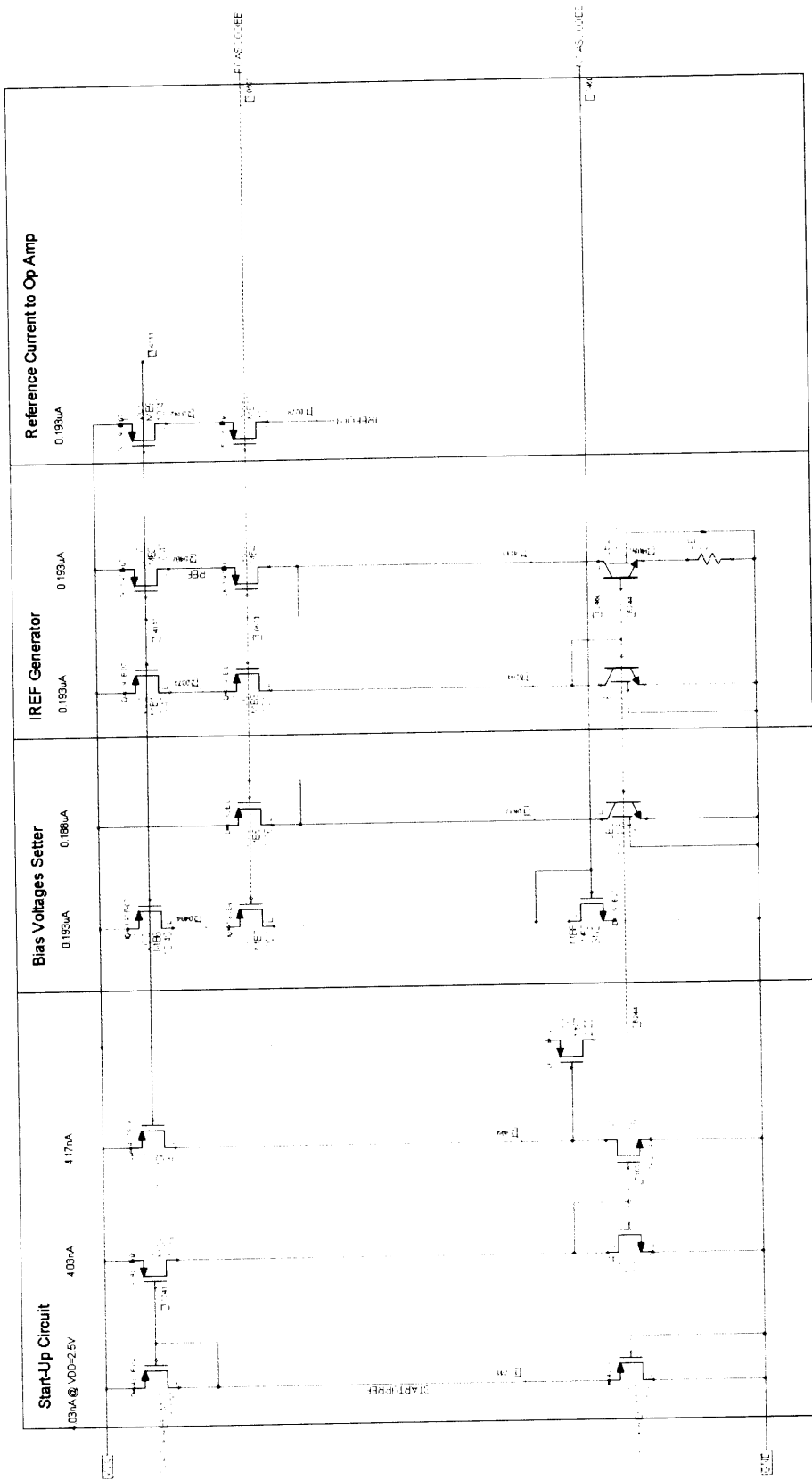

Figure C-20: Schematic of Bias Cell for 20µA Micropower Op Amp with Hybrid Symmetric Embedded Cascode Compensation (HSECC)

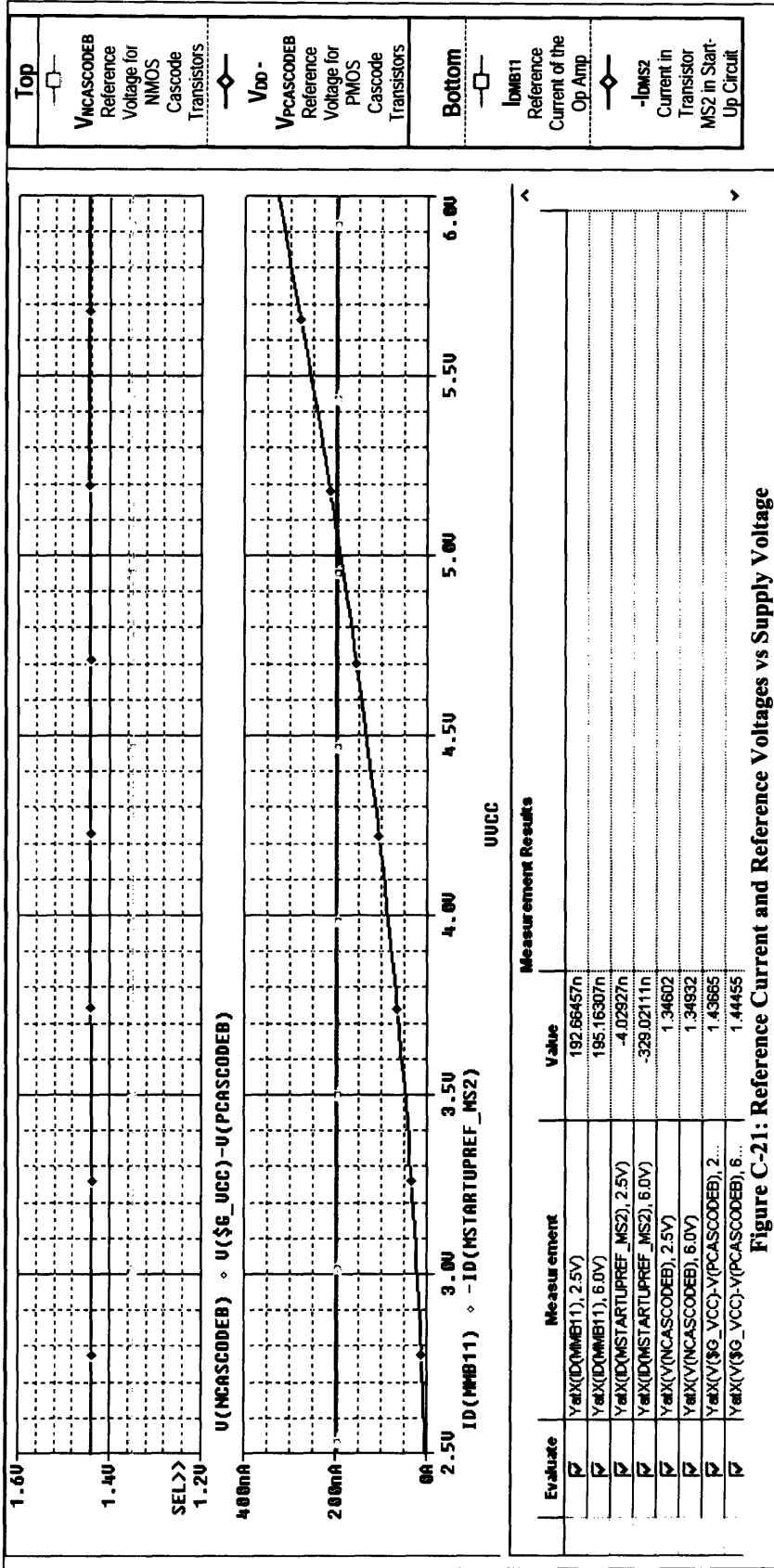

Figure C-21: Reference Current and Reference Voltages vs Supply Voltage

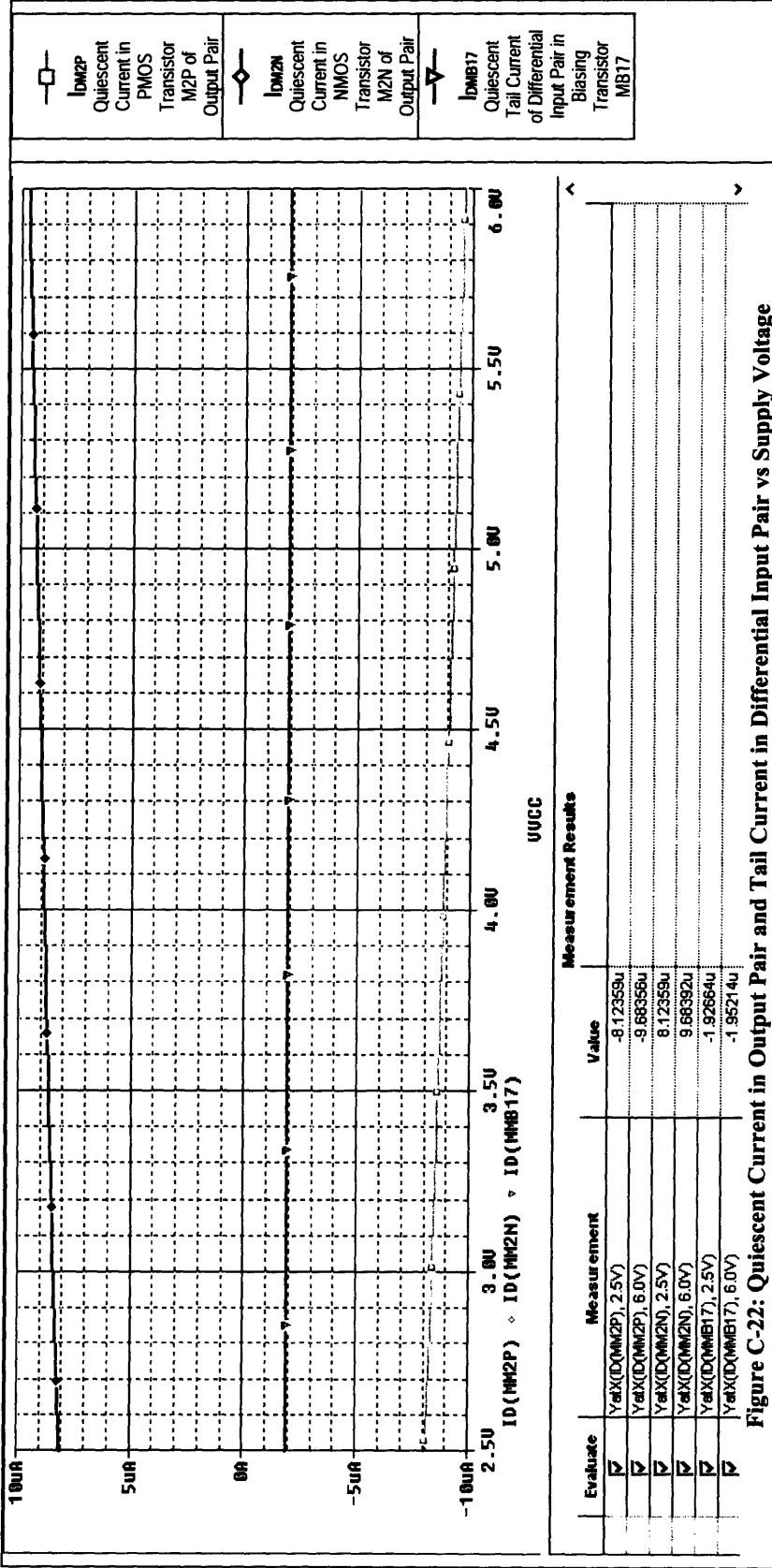

Figure C-22: Quiescent Current in Output Pair and Tail Current in Differential Input Pair vs Supply Voltage

Appendix D Schematics and Characteristics of 20 μ A Micropower Op Amp with Hybrid Asymmetric Embedded Cascode Compensation (HAECC)

LIST OF FIGURES IN APPENDIX D

Table D: Characteristics of 20 μ A Micropower Op Amp with Hybrid Asymmetric Embedded Cascode Compensation (HAECC) from Simulation.....	133
Figure D-1: Schematic of 20 μ A Micropower Op Amp with Hybrid Asymmetric Embedded Cascode Compensation (HAECC).....	135
Figure D-2: Frequency Response with $C_L=100\text{pF}$ and $R_L=100\text{k}\Omega$	136
Figure D-3: Frequency Response with $C_L=0, 10, 100, 200, 500\text{pF}$ and $R_L=100\text{k}\Omega$	137
Figure D-4: CMRR vs Frequency with $V_{IN}=0, 0.65, 1.3\text{V}$	138
Figure D-5: PSRR+ vs Frequency with $V_{IN}=0, 0.65, 1.3\text{V}$	139
Figure D-6: PSRR- vs Frequency with $V_{IN}=0, 0.65, 1.3\text{V}$	139
Figure D-7: Small-Signal Transient Response with $C_L=100\text{pF}$ and $R_L=100\text{k}\Omega$	140
Figure D-8: Small-Signal Transient Response with $C_L=0, 10, 100\text{pF}$ and $R_L=100\text{k}\Omega$..	140
Figure D-9: Large-Signal Transient Response with $C_L=100\text{pF}$ and $R_L=100\text{k}\Omega$	141
Figure D-10: Large-Signal Transient Response with $C_L=0, 10, 100\text{pF}$ and $R_L=100\text{k}\Omega$	141
Figure D-11: Output Transistors Current vs I_{LOAD}	142
Figure D-12: Rail-to-Rail Output Voltage (v_{IN} and v_{OUT} with $A_V=5$).....	142
Figure D-13: Positive Output Voltage Swing vs I_{SOURCE}	143
Figure D-14: Negative Output Voltage Swing vs I_{SINK}	143
Figure D-15: Short-Circuit Source Current vs Supply Voltage.....	144
Figure D-16: Short-Circuit Sink Current vs Supply Voltage.....	144
Figure D-17: Frequency Response with $C_L=0\text{pF}$ and $R_L=100\text{k}\Omega$ @ $I_L=-1.0, -0.5, 0.0, 0.5, 1.0\text{mA}$	145

Figure D-18: Frequency Response with $C_L=10\text{pF}$ and $R_L=100\text{k}\Omega$ @ $I_L=-1.0, -0.5, 0.0, 0.5, 1.0\text{mA}$	145
Figure D-19: Frequency Response with $C_L=100\text{pF}$ and $R_L=100\text{k}\Omega$ @ $I_L=-1.0, -0.5, 0.0, 0.5, 1.0\text{mA}$	145
Figure D-20: Schematic of Bias Cell for $20\mu\text{A}$ Micropower Op Amp with Hybrid Asymmetric Embedded Cascode Compensation (HA ECC).....	146
Figure D-21: Reference Current and Reference Voltages vs Supply Voltage.....	147
Figure D-22: Quiescent Current in Output Pair and Tail Current in Differential Input Pair vs Supply Voltage.....	148

Table D: Characteristics of 20 μ A Micropower Op Amp with Hybrid Asymmetric Embedded Cascode Compensation (HAECC) from Simulation

Simulation results are at 25°C. $V_{DD} = 2.5V$ and $V_{SS} = 0V$.					
Primary Characteristics					
Symbol	Parameter	Condition	Value		Unit
			Specified	Simulated	
GBW^{26}	Gain Bandwidth Product	$C_L = 100pF$ $R_L = 100k\Omega$	> 0.3	0.589 ($\Phi_M = 61.8^\circ$)	MHz
A_{VOL}	Large-Signal Voltage Gain (DC Open-Loop Gain)	$C_L = 100pF$ $R_L = 100k\Omega$	> 100	122	dB
I_S	Supply Current	No Load	< 21	19.95	μA
V_{INCM}^{27}	Input Common-Mode Range	-	> $V_{DD} - 1.25V$ and must include negative supply voltage	1.3 and includes negative supply voltage	V
V_{OS}^{28}	(Untrimmed) Input Offset Voltage	$V_{INCM} = 0.65V$	< 5	4.17	mV
V_{OUT}	V_{OUTH}	High Output Voltage $I_{SOURCE} = 1.0mA$	> $V_{DD} - 0.3V$	2.34	V
	V_{OUTL}	Low Output Voltage $I_{SINK} = 1.0mA$	< $V_{SS} + 0.3V$	0.19	V
I_{SOURCE}^{29}	Output Source Current	$C_L = 100pF$ $R_L = 100k\Omega$	> 1.0	1.55	mA
I_{SINK}	Output Sink Current	$C_L = 100pF$ $R_L = 100k\Omega$	> 1.0	1.03	mA
Secondary Characteristics					
Symbol	Parameter	Condition	Value		Unit
			Specified	Simulated	
SR+	Positive Going Slew Rate	$A_V = 1V/V, 1V$ Step	> 0.15	0.315	V/ μs
SR-	Negative Going Slew Rate	$A_V = 1V/V, 1V$	< -0.15	-0.342	V/ μs

²⁶ Gain bandwidth product per supply current $GBW/I_S = 29.5MHz/mA @ C_L = 100pF$.

²⁷ Verified by CMRR simulation in Figure D-4.

²⁸ Conservative estimate from calculation.

²⁹ Maximum output source current is measured when the other transistor in the output pair starts to turn off, i.e. its current goes down to as low as $1\mu A$.

		Step			
CMRR	Common Mode Rejection Ratio	@ DC	> 60	144	dB
PSRR+	Positive Power Supply Rejection Ratio	@ DC	> 60	84.6	dB
PSRR-	Negative Power Supply Rejection Ratio	@ DC	> 60	99.5	dB
t_s	0.1% Settling Time	$A_v = 1V/V, 1V$ Step	< 10	3.70	μs

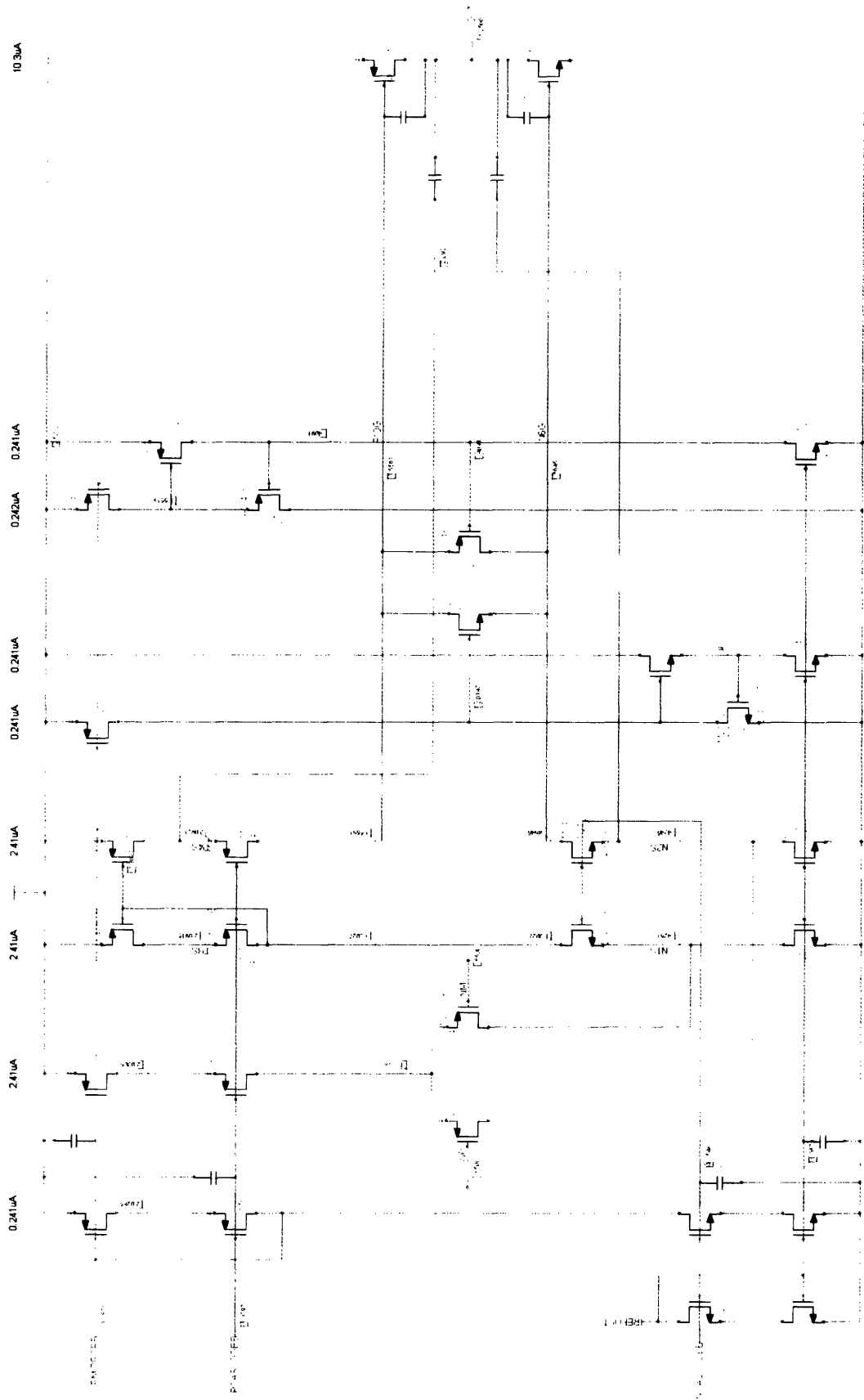

Figure D-1: Schematic of 20µA Micropower Op Amp with Hybrid Asymmetric Embedded Cascade Compensation (HA-ECC)

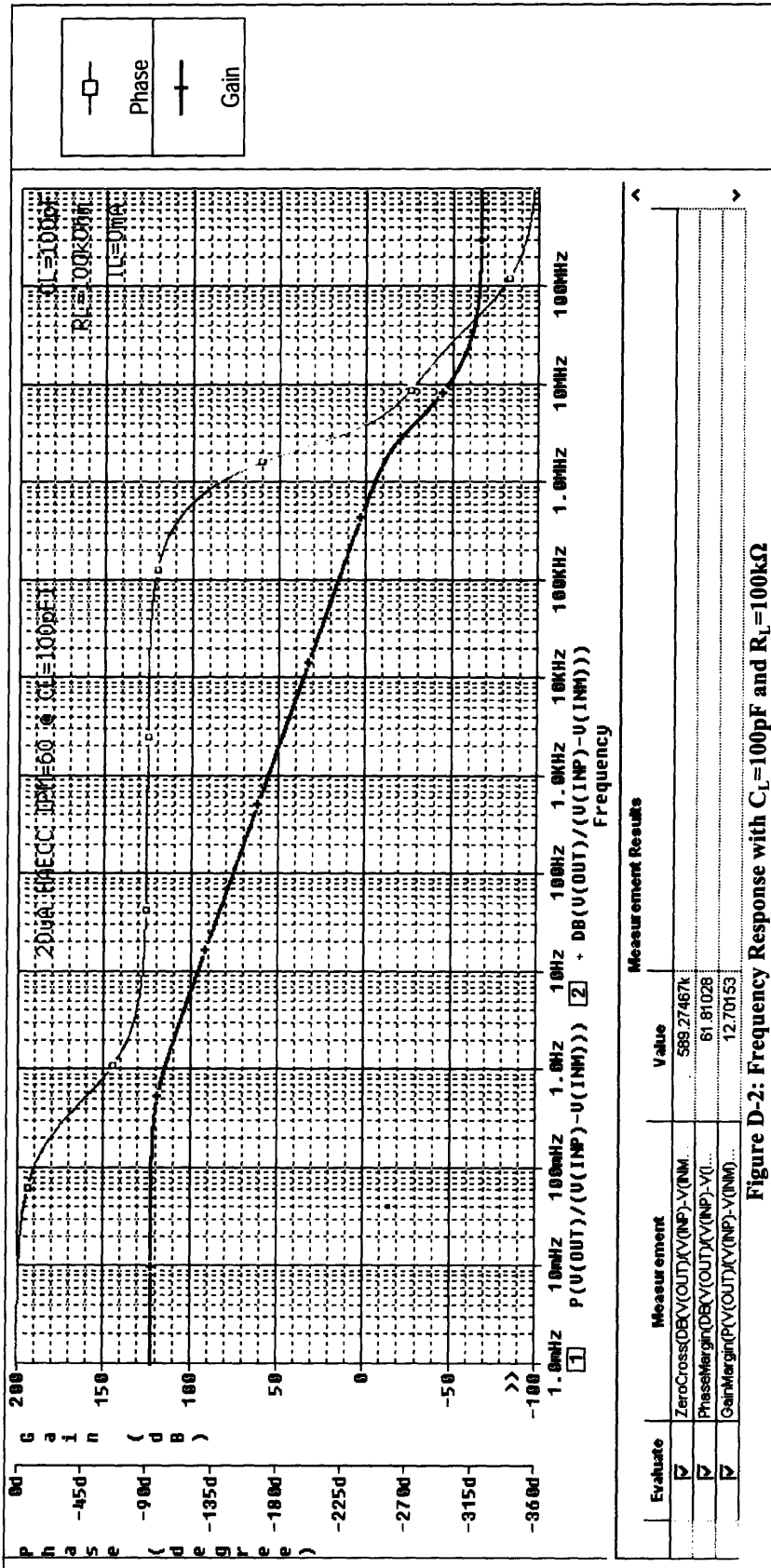

Figure D-2: Frequency Response with $C_L=100\text{pF}$ and $R_L=100\text{k}\Omega$

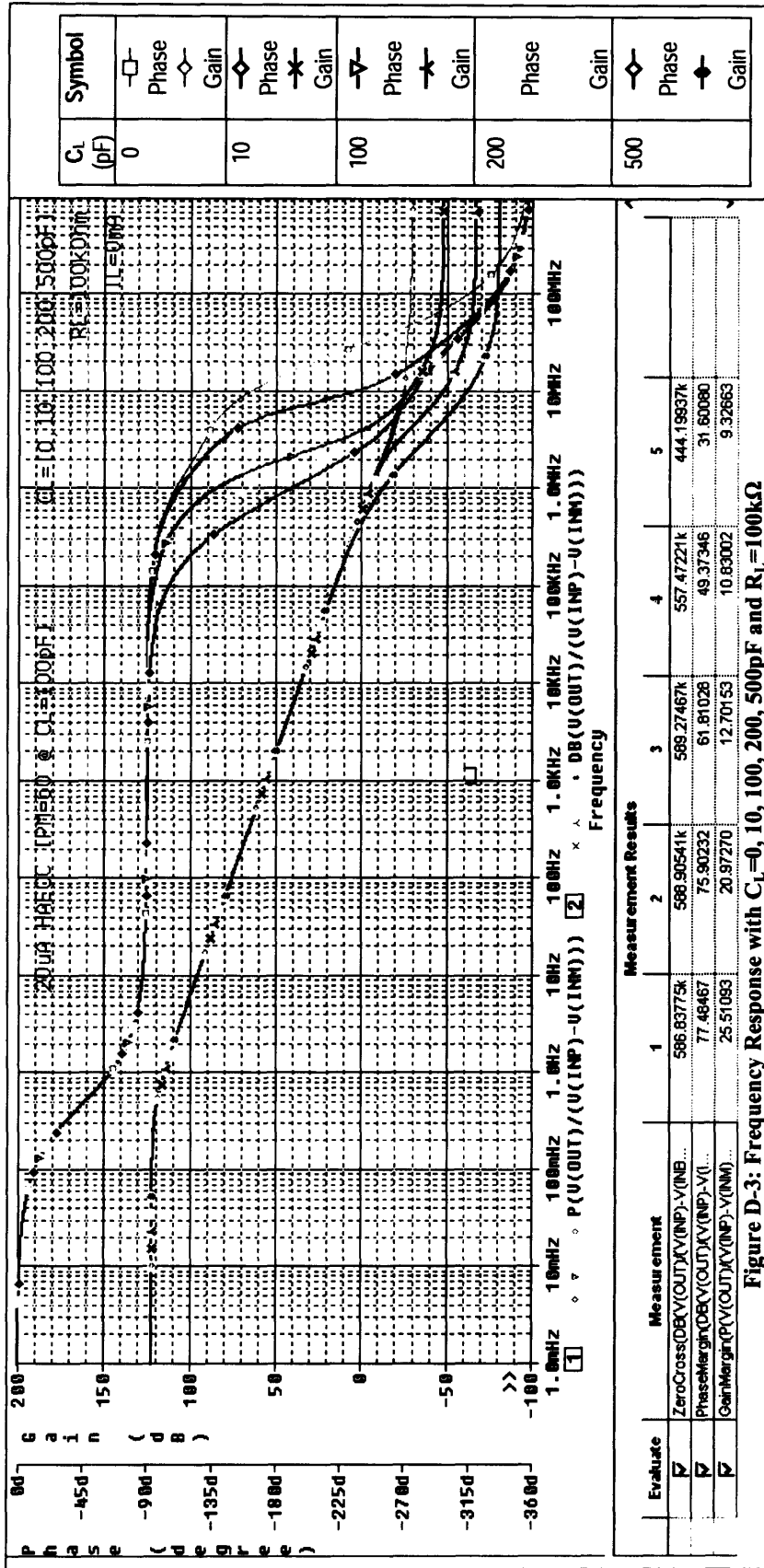

Figure D-3: Frequency Response with $C_L=0, 10, 100, 200, 500\text{pF}$ and $R_L=100\text{k}\Omega$

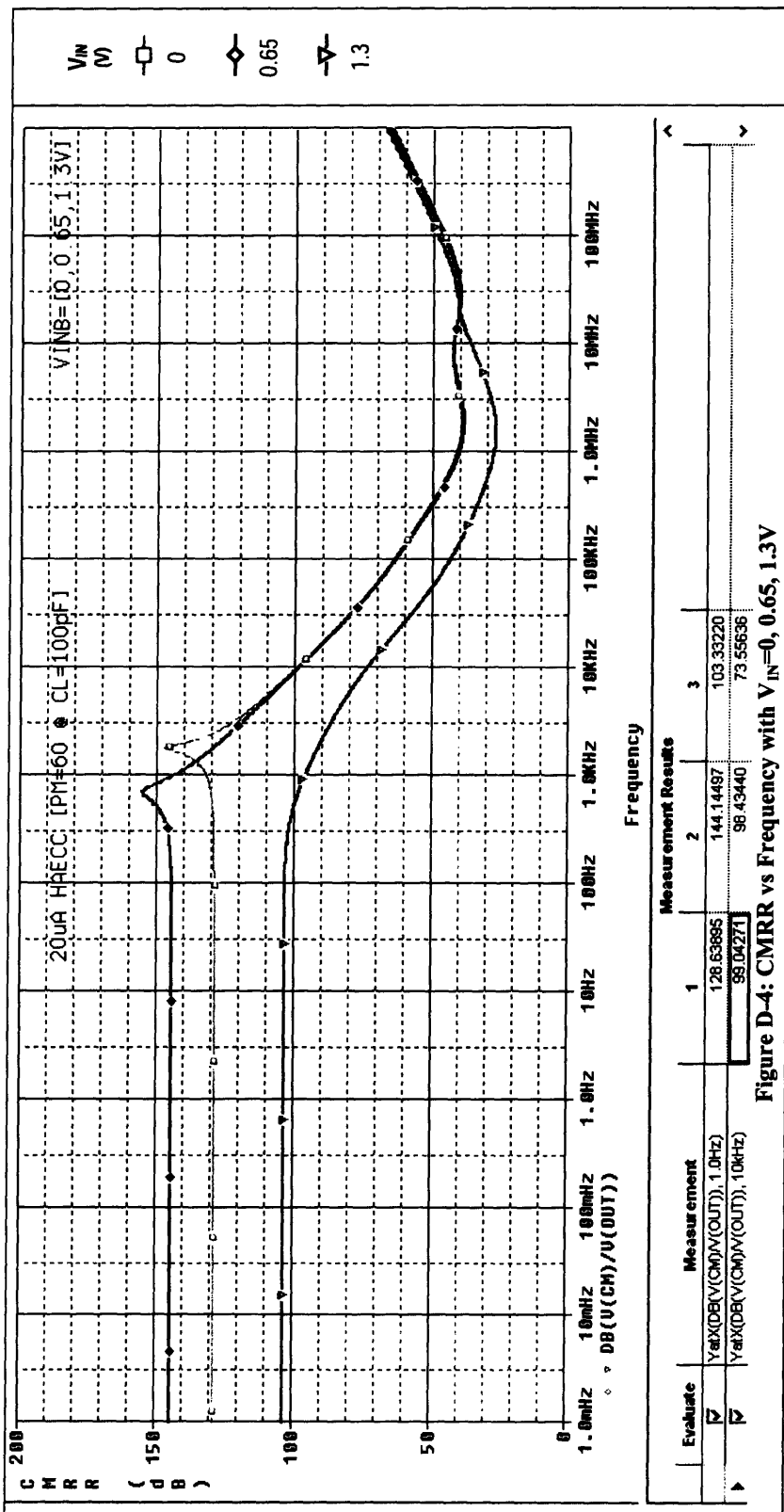

Figure D-4: CMRR vs Frequency with VIN=0, 0.65, 1.3V

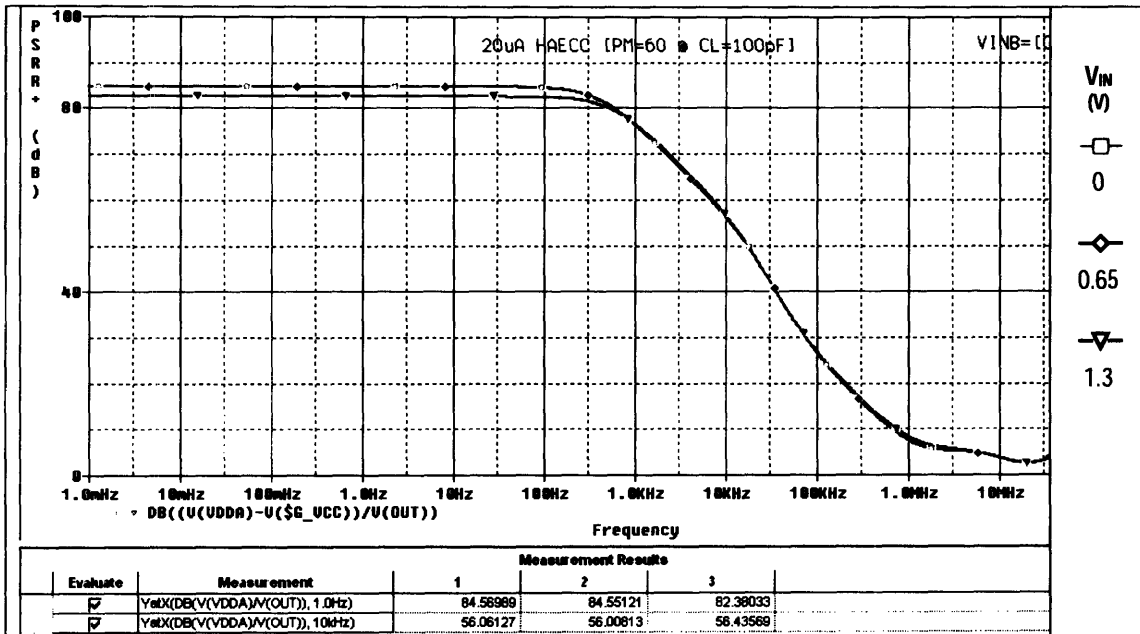

Figure D-5: PSRR+ vs Frequency with $V_{IN}=0, 0.65, 1.3V$

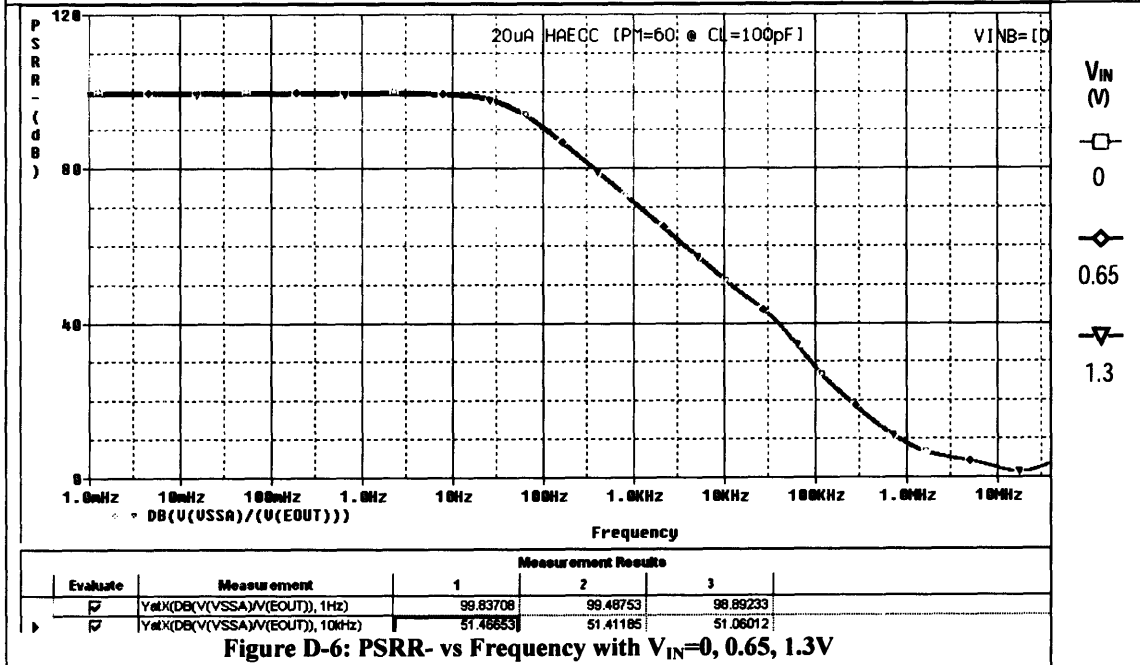

Figure D-6: PSRR- vs Frequency with $V_{IN}=0, 0.65, 1.3V$

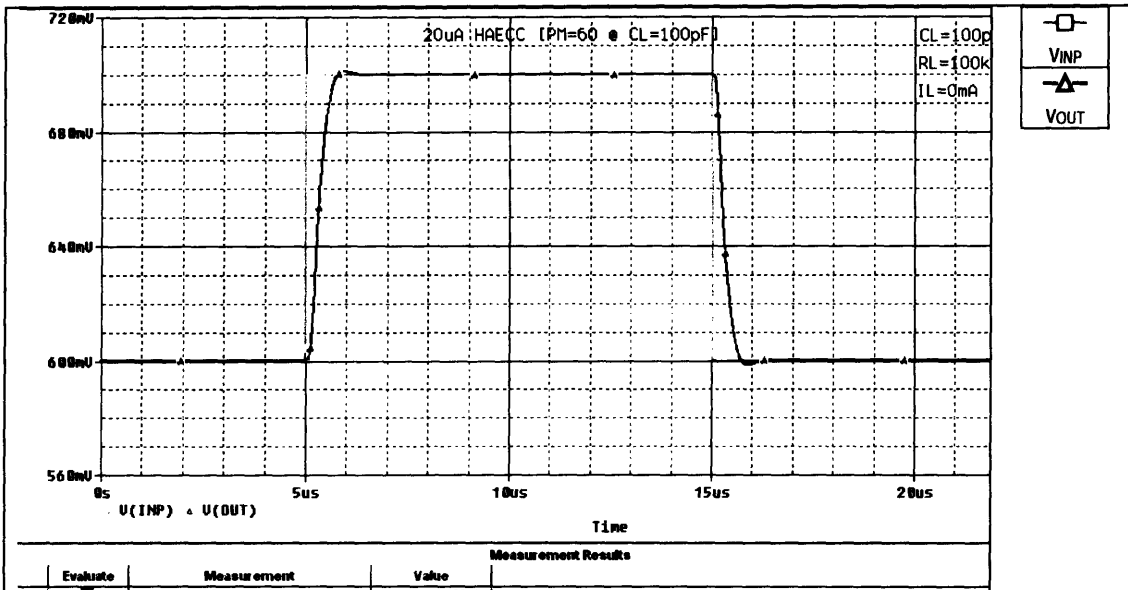

Figure D-7: Small-Signal Transient Response with $C_L=100\text{pF}$ and $R_L=100\text{k}\Omega$

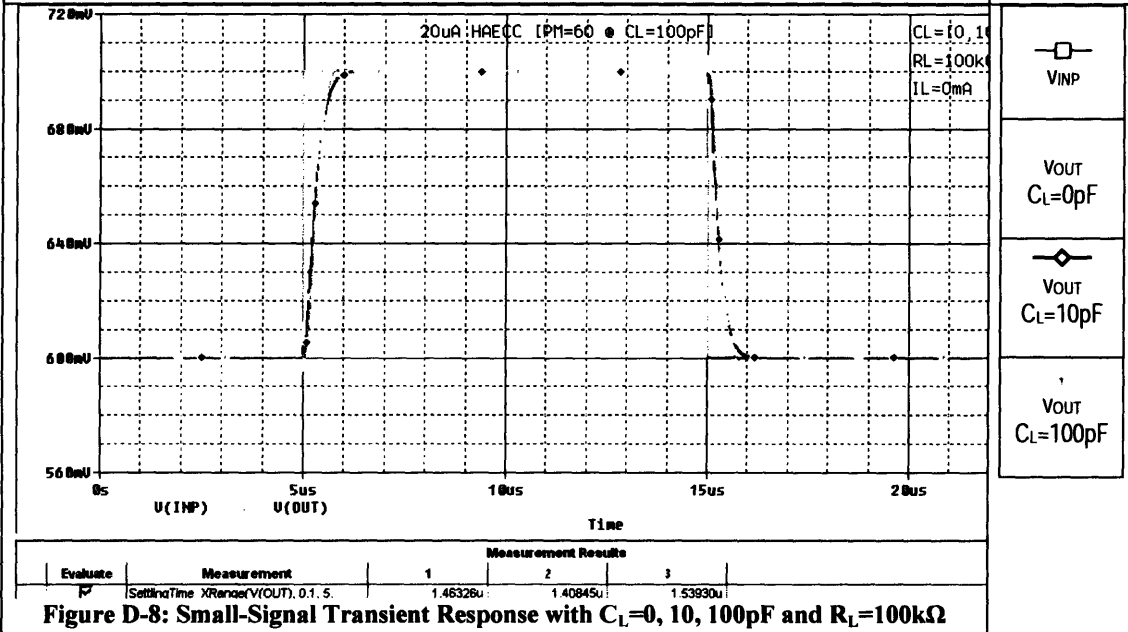

Figure D-8: Small-Signal Transient Response with $C_L=0, 10, 100\text{pF}$ and $R_L=100\text{k}\Omega$

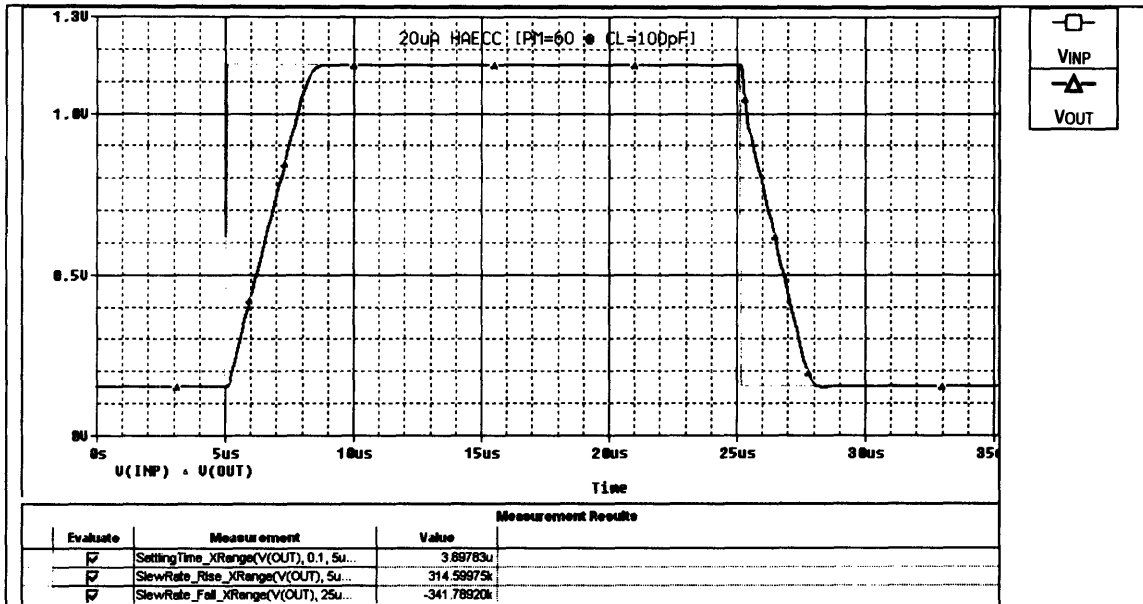

Figure D-9: Large-Signal Transient Response with $C_L=100\text{pF}$ and $R_L=100\text{k}\Omega$

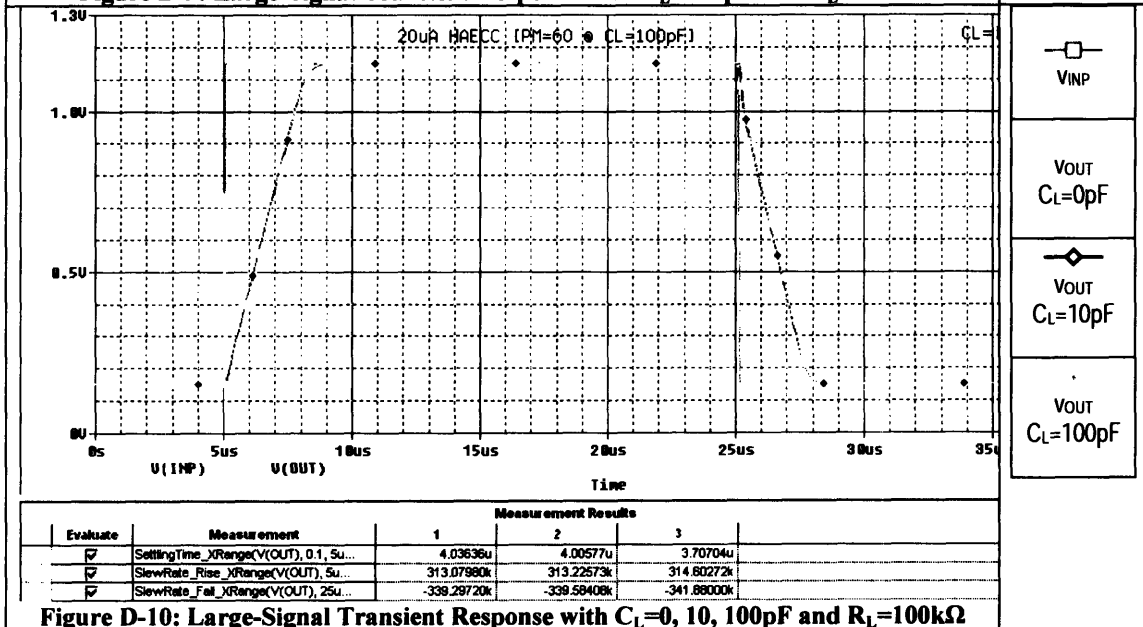

Figure D-10: Large-Signal Transient Response with $C_L=0, 10, 100\text{pF}$ and $R_L=100\text{k}\Omega$

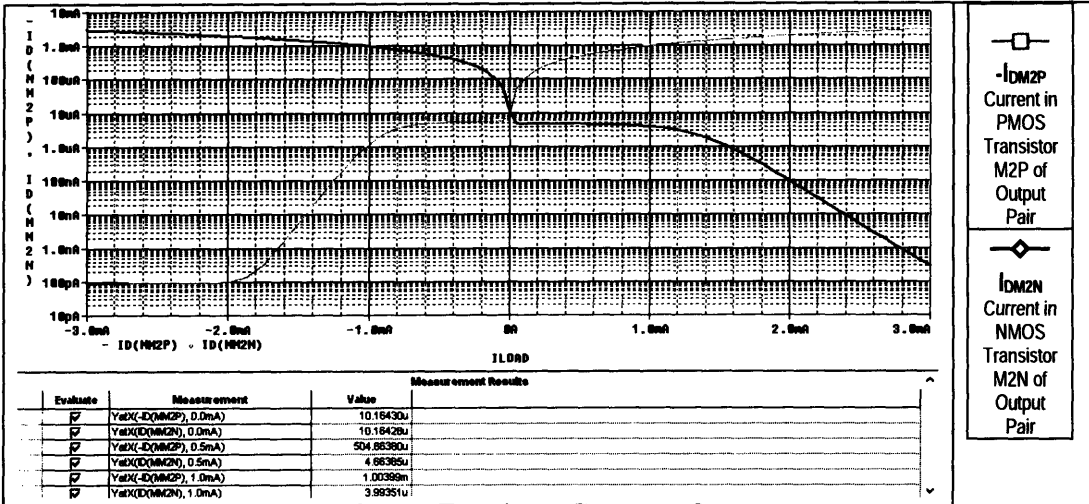

Figure D-11: Output Transistors Current vs I_{LOAD}

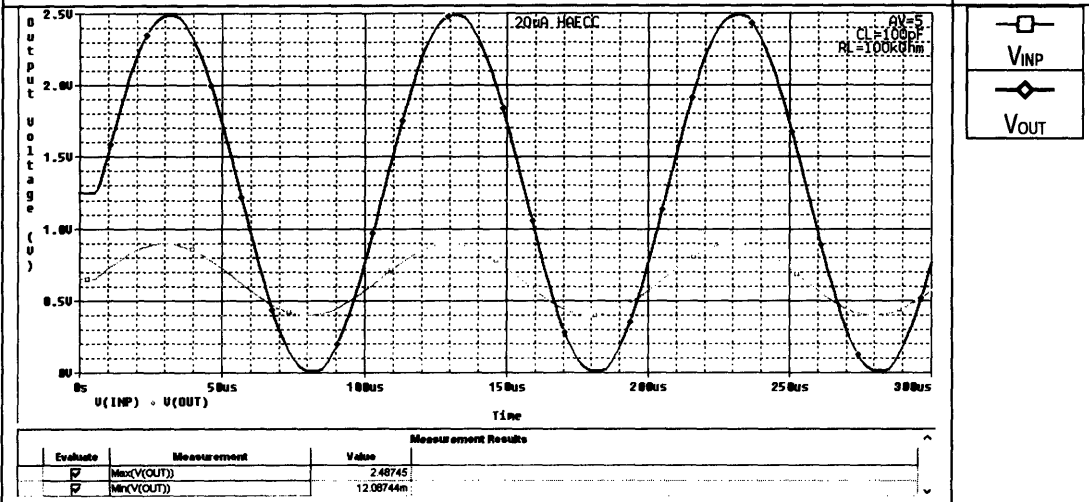

Figure D-12: Rail-to-Rail Output Voltage (V_{IN} and V_{OUT} with $A_V=5$)

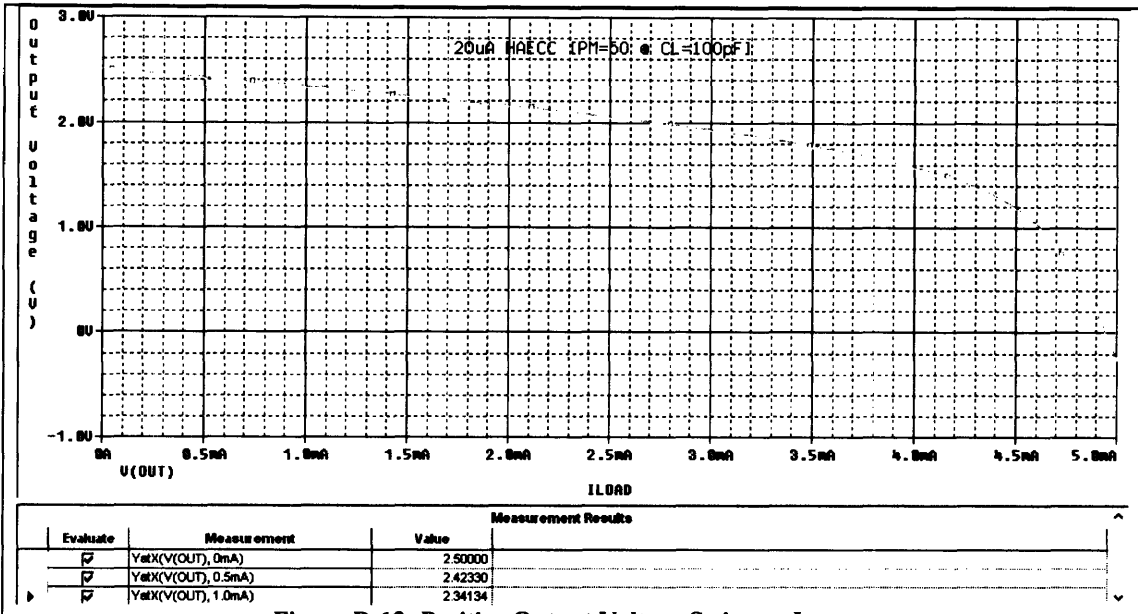

Figure D-13: Positive Output Voltage Swing vs I_{SOURCE}

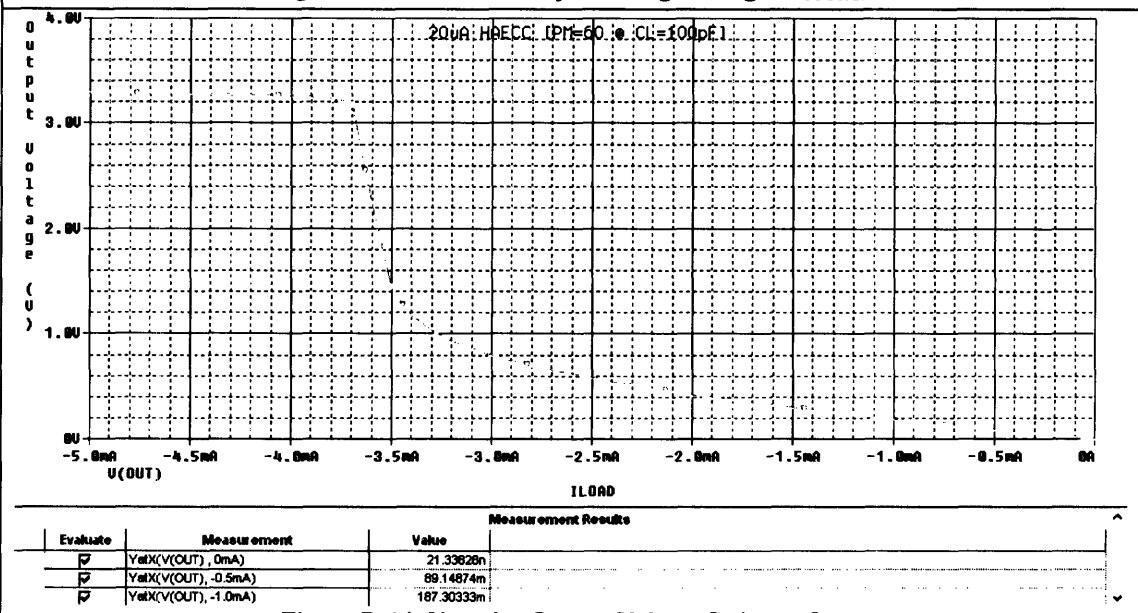

Figure D-14: Negative Output Voltage Swing vs I_{SINK}

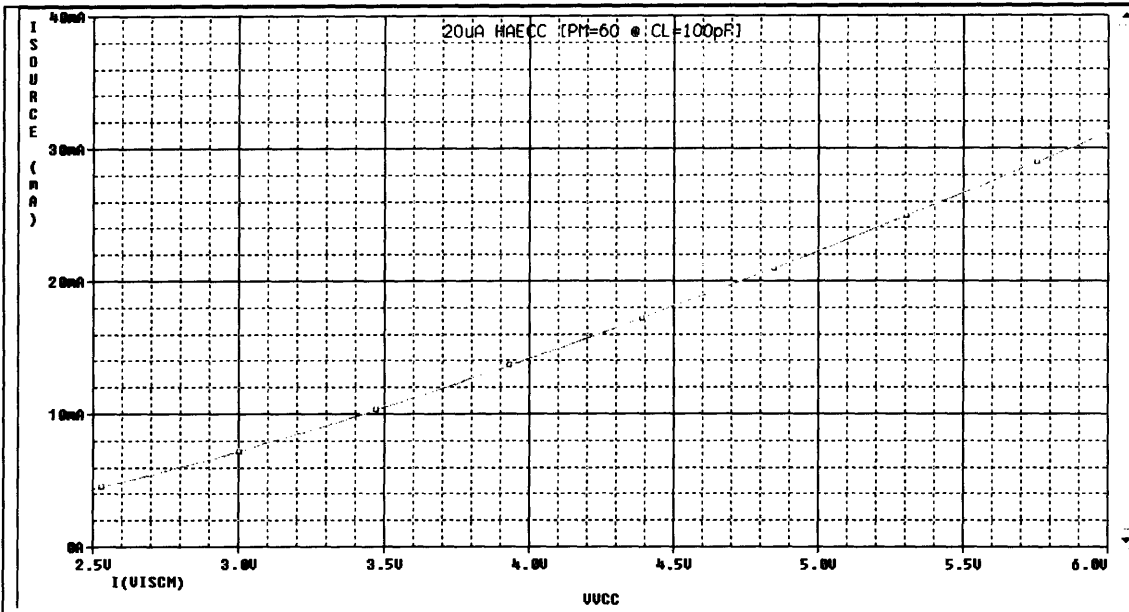

Figure D-15: Short-Circuit Source Current vs Supply Voltage

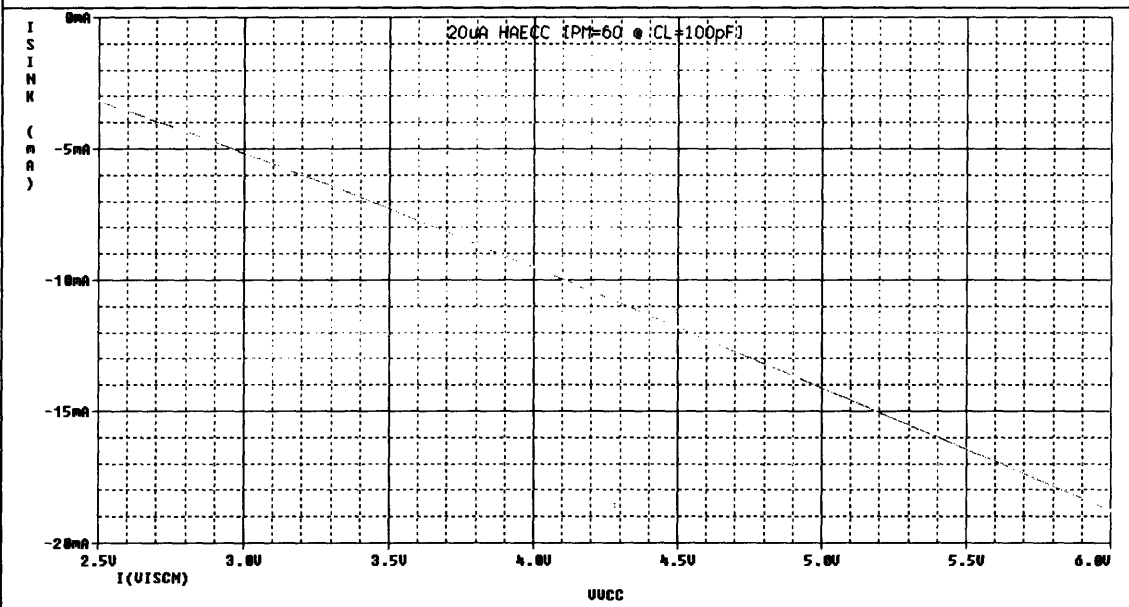
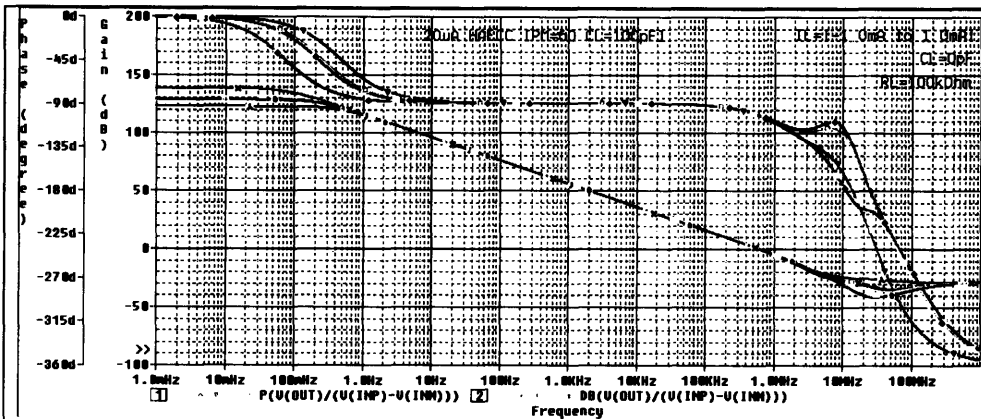
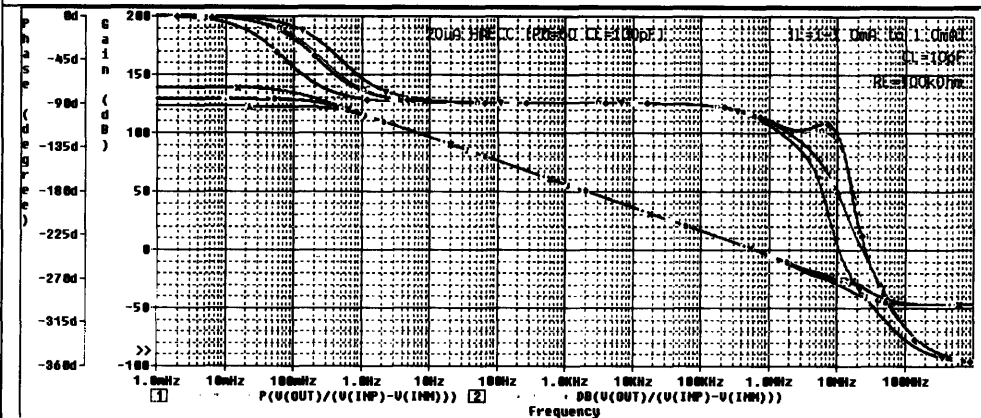

Figure D-16: Short-Circuit Sink Current vs Supply Voltage



Measurement Results						
Evaluate	Measurement	1	2	3	4	5
<input checked="" type="checkbox"/>	ZeroCross(DBV(OUT)(V(INP)-V(INM))	504.07659k	504.65041k	506.83775k	501.48468k	500.26904k
<input checked="" type="checkbox"/>	PhaseMargin(DBV(OUT)(V(INP)-V(INM))	78.80797	78.88815	77.48467	78.35283	78.37453
<input checked="" type="checkbox"/>	GainMargin(PV(OUT)(V(INP)-V(INM))	34.25113	32.20876	25.51083	32.79536	32.45639
<input checked="" type="checkbox"/>	Peak(DBV(OUT)(V(INP)-V(INM)), 1)	<Evaluation Failed>	<Evaluation Failed>	<Evaluation Failed>	<Evaluation Failed>	<Evaluation Failed>

Figure D-17: Frequency Response with $C_L=0pF$ and $R_L=100k\Omega$ @ $I_L=-1.0, -0.5, 0.0, 0.5, 1.0mA$



Measurement Results						
Evaluate	Measurement	1	2	3	4	5
<input checked="" type="checkbox"/>	ZeroCross(DBV(OUT)(V(INP)-V(INM))	504.38701k	504.94673k	506.90541k	501.81251k	500.53058k
<input checked="" type="checkbox"/>	PhaseMargin(DBV(OUT)(V(INP)-V(INM))	78.40878	78.50589	75.90232	78.17528	78.22980
<input checked="" type="checkbox"/>	GainMargin(PV(OUT)(V(INP)-V(INM))	30.42895	26.44117	20.97270	29.09788	29.71986
<input checked="" type="checkbox"/>	Peak(DBV(OUT)(V(INP)-V(INM)), 1)	<Evaluation Failed>	-25.28781	<Evaluation Failed>	<Evaluation Failed>	<Evaluation Failed>

Figure D-18: Frequency Response with $C_L=10pF$ and $R_L=100k\Omega$ @ $I_L=-1.0, -0.5, 0.0, 0.5, 1.0mA$

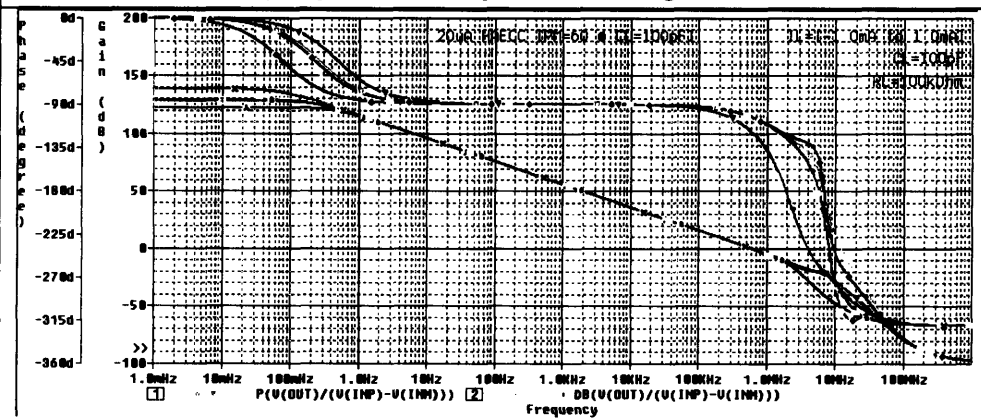

Measurement Results						
Evaluate	Measurement	1	2	3	4	5
<input checked="" type="checkbox"/>	ZeroCross(DBV(OUT)(V(INP)-V(INM))	506.93508k	507.48075k	509.27467k	504.57008k	502.74819k
<input checked="" type="checkbox"/>	PhaseMargin(DBV(OUT)(V(INP)-V(INM))	76.81241	77.03387	61.81028	76.56415	76.91957
<input checked="" type="checkbox"/>	GainMargin(PV(OUT)(V(INP)-V(INM))	23.31780	19.51872	12.70153	19.05887	20.37380
<input checked="" type="checkbox"/>	Peak(DBV(OUT)(V(INP)-V(INM)), 1)	<Evaluation Failed>	-19.24604	<Evaluation Failed>	<Evaluation Failed>	<Evaluation Failed>

Figure D-19: Frequency Response with $C_L=100pF$ and $R_L=100k\Omega$ @ $I_L=-1.0, -0.5, 0.0, 0.5, 1.0mA$

I_L (mA)	Symbol
-1.0	Phase Gain
-0.5	Phase Gain
0.0	Phase Gain
0.5	Phase Gain
1.0	Phase Gain

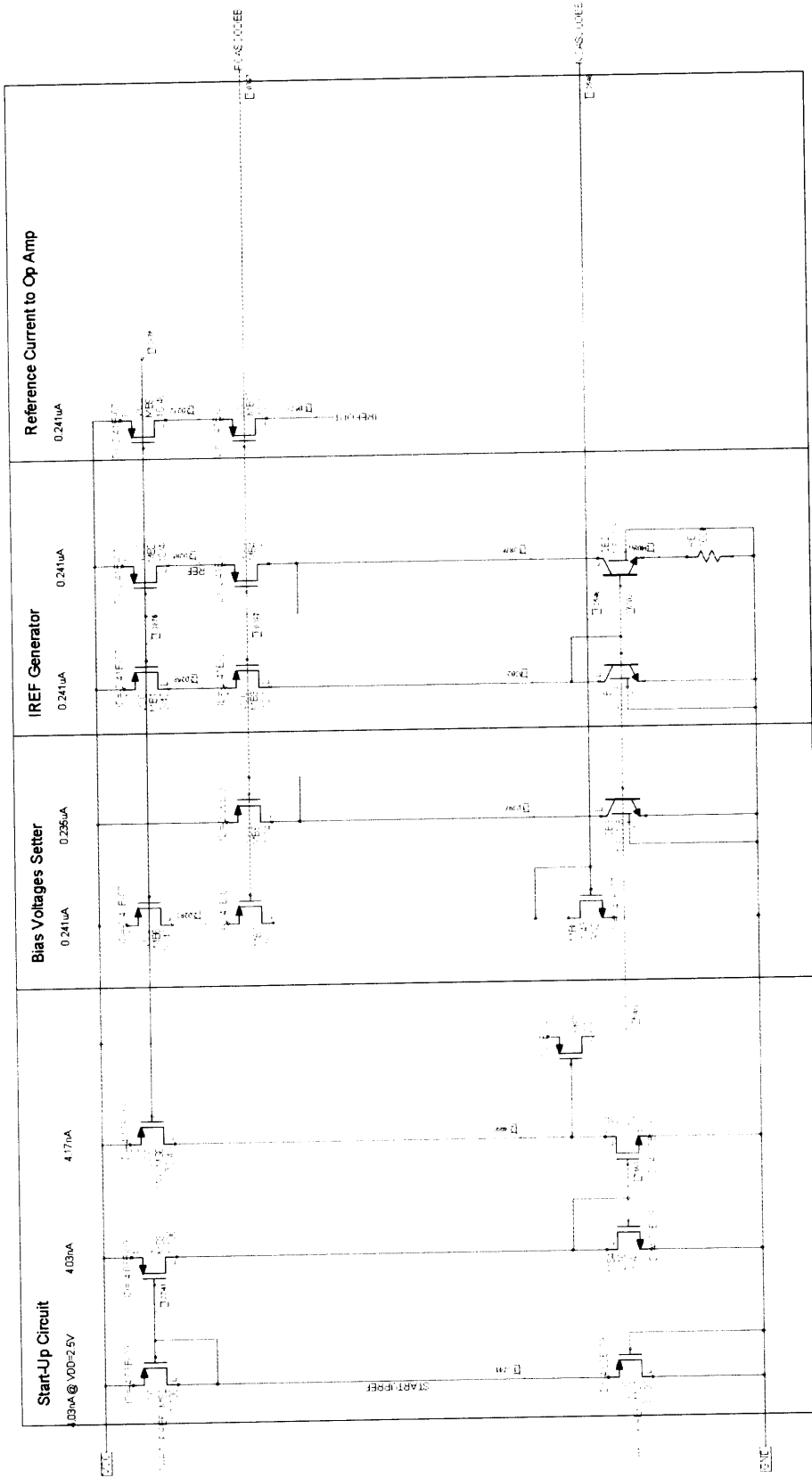

Figure D-20: Schematic of Bias Cell for 20µA Micropower Op Amp with Hybrid Asymmetric Embedded Cascode Compensation (HA-ECC)

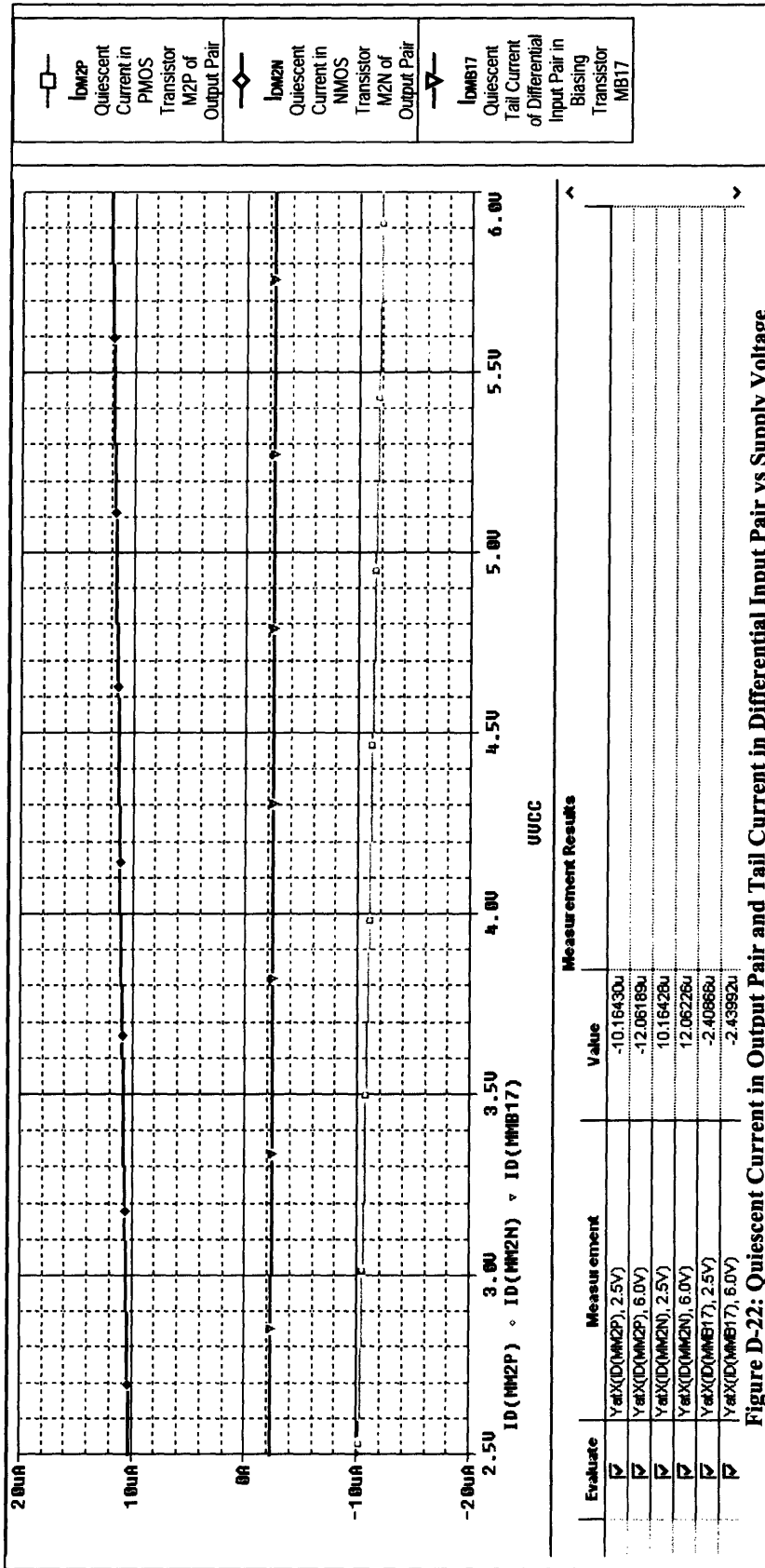

Figure D-22: Quiescent Current in Output Pair and Tail Current in Differential Input Pair vs Supply Voltage

Bibliography

Chapter 1

- [1] Linear Technology Corporation, “LTC1541/LTC1542 Micropower Op Amp, Comparator and Reference” [Datasheet], Milpitas, CA, 1998.
- [2] Linear Technology Corporation, “LTC2054/LTC2055 Single/Dual Micropower Zero-Drift Operational Amplifiers” [Datasheet], Milpitas, CA, 2004.
- [3] Maxim Integrated Products, “MAX9914-MAX9917 1MHz, 20 μ A, Rail-to-Rail I/O Op Amps with Shutdown” [Datasheet], Sunnyvale, CA, 2005.
- [4] Micrel, Inc., “MIC861 Teeny™ Ultra Low Power Op Amp” [Datasheet]. San Jose, CA, 2001.
- [5] Linear Technology Corporation, “Medical Diagnostics,” *Linear Technology Chronicle*, vol. 12, no. 5, June 2003.
- [6] Brendan Whelan, personal communication.

Chapter 2

- [7] David Johns and Kenneth Martin, Analog Integrated Circuit Design, 2nd ed., John Wiley & Sons, Inc., 1st ed., 1997, Chapter 5.
- [8] Paul R. Gray, Paul J. Hurst, Stephen H. Lewis, and Robert G. Meyer, Analysis and Design of Analog Integrated Circuits, 4th ed., John Wiley & Sons, Inc., 2001, Chapter 12.
- [9] David Johns and Kenneth Martin, Analog Integrated Circuit Design, 2nd ed., John Wiley & Sons, Inc., 1st ed., 1997, Chapter 6.
- [10] Brendan Whelan, personal communication.
- [11] L. N. Alves and R. L. Aguiar, “Frequency behavior of classical current mirrors,” *9th International Conference on Electronics, Circuits and Systems*, vol. 1, pp. 189-192, 2002.
- [12] Paul R. Gray, Paul J. Hurst, Stephen H. Lewis, and Robert G. Meyer, Analysis and Design of Analog Integrated Circuits, 4th ed., John Wiley & Sons, Inc., 2001, Chapter 6.

- [13] Boris Murmann, "Lecture 11: Offset Voltage, Current Mirrors," *EE214 Analog Integrated Circuit Design Lecture Notes*, 2004.
- [14] P. Kinget and M. Steyaert, "Impact of transistor mismatch on the speed-accuracy-power trade-off of analog CMOS circuits," *Proceedings of the IEEE Custom Integrated Circuits Conference*, pp. 333-336, 5-8 May 1996.
- [15] M. J. M. Pelgrom, A. C. J. Duinmaijer, and A. P. G. Welbers, "Matching properties of MOS transistors," *IEEE Journal of Solid-State Circuits*, vol. 24, pp. 1433 - 1439, October 1989. (as referred in [14]).
- [16] Paul R. Gray, Paul J. Hurst, Stephen H. Lewis, and Robert G. Meyer, *Analysis and Design of Analog Integrated Circuits*, 4th ed., John Wiley & Sons, Inc., 2001, p. 248 (Table of Area under Gaussian Curve).

Chapter 3

- [17] Paul R. Gray and Robert G. Meyer, "MOS operational amplifier design--A tutorial overview," *IEEE Journal of Solid-State Circuits*, vol. 17, pp. 969-982, December 1982.
- [18] Johan H. Huijsing, *Operational Amplifiers: Theory and Design*, 1st ed., Kluwer Academic Publishers, Boston, 2001.
- [19] Paul R. Gray, Paul J. Hurst, Stephen H. Lewis, and Robert G. Meyer, *Analysis and Design of Analog Integrated Circuits*, 4th ed., John Wiley & Sons, Inc., 2001, Chapter 5.
- [20] D. M. Monticelli, "A quad CMOS single-supply op amp with rail-to-rail output swing," *IEEE Journal of Solid-State Circuits*, vol. 21, pp. 1026 - 1034, December 1986. (as referred in [21]-[22])
- [21] K. de Langen and J. H. Huijsing, "Compact low-voltage power-efficient operational amplifier cells for VLSI," *IEEE Journal of Solid-State Circuits*, vol. 33, pp. 1482 - 1496, October 1998.
- [22] K. de Langen and J. H. Huijsing, "Low-voltage power-efficient operational amplifier design techniques — An overview," *2003 IEEE Custom Integrated Circuits Conference*, September 2003.
- [23] Brendan J. Whelan, personal communication.
- [24] David Johns and Kenneth Martin, *Analog Integrated Circuit Design*, 2nd ed., John Wiley & Sons, Inc., 1st ed., 1997, p. 59.

Chapter 4

- [25] Brendan J. Whelan, personal communication.
- [26] Paul R. Gray, Paul J. Hurst, Stephen H. Lewis, and Robert G. Meyer, Analysis and Design of Analog Integrated Circuits, 4th ed., John Wiley & Sons, Inc., 2001, pp. 16, Chapter 4.
- [27] David Johns and Kenneth Martin, Analog Integrated Circuit Design, 2nd ed., John Wiley & Sons, Inc., 1st ed., 1997, Chapter 1.

Chapter 5

- [28] Ka Nang Leung and Philip K. T. Mok, "Analysis of multistage amplifier—Frequency compensation," *IEEE Transactions on Circuits and Systems I*, vol. CAS-48, pp. 1041 - 1056, September 2001.
- [29] G. Palmisano and G. Palumbo, "A compensation strategy for two-stage CMOS opamps based on current buffer," *IEEE Transactions on Circuits and Systems I: Fundamental Theory and Applications*, vol. 44, issue 3, March 1997, pp. 257-262.
- [30] B. K. Ahuja, "An improved frequency compensation technique for CMOS operational amplifiers," *IEEE Journal of Solid-State Circuits*, vol. 18, issue 6, December 1983, pp. 629-633.
- [31] D. B. Ribner and M. A. Copeland, "Design techniques for cascoded CMOS op amps with improved PSRR and common-mode input range," *IEEE Journal of Solid-State Circuits*, vol. 19, issue 8, December 1984, pp. 919-925.
- [32] P. J. Hurst, S. H. Lewis, J. P. Aram, and K. C. Dyer, "Miller compensation using current buffers in fully differential CMOS two-stage operational amplifiers," *IEEE Transactions on Circuits and Systems I: Regular Papers*, vol. 51, issue 2, February 2004, pp. 275-285.
- [33] Klass-Jan de Langen and Johan H. Huijsing, Compact Low-Voltage and High-Speed CMOS, BiCMOS and Bipolar Operational Amplifiers, 1st ed., Kluwer Academic Publishers, 1999.
- [34] Ron Hogervorst and Johan H. Huijsing, Design of Low-Voltage Low-Power Operational Amplifier Cells, 1st ed., Kluwer Academic Publishers, 1996.