

11.3) CMOS Folded-Cascode Op-Amp

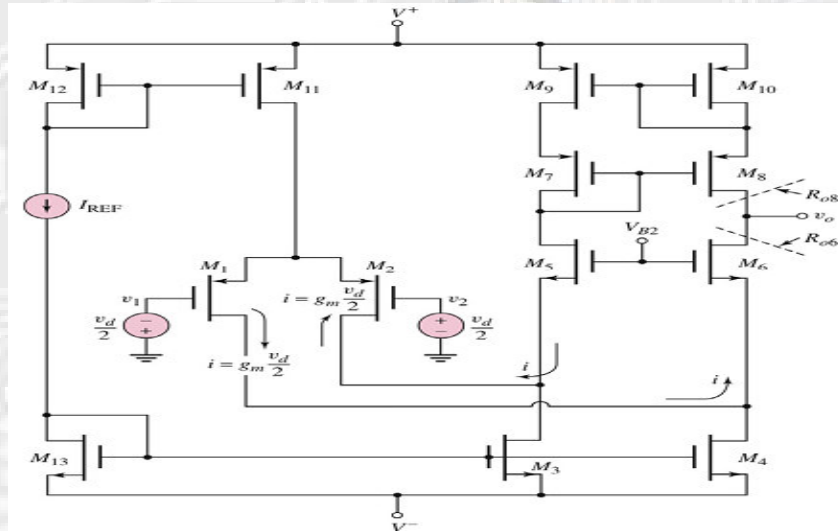

Figure 13.17: CMOS folded-cascode amplifier.

28

11.3) CMOS Folded-Cascode Op-Amp (Cont)

- Folded-cascode configuration can be applied to the diff-amp as shown in **Figure 13.17**

- M_1 and M_2 : PMOS input **differential pair**.
- M_5 and M_6 : cascode transistors.
- M_7 to M_{10} : form a modified Wilson current mirror acting as **active load**.
- The biasing V_{B2} must be provided by a separate network.

29

11.3) CMOS Folded-Cascode Op-Amp (Cont)

- Assuming that transistors M_3 , M_4 and $M_{11} - M_{13}$ are all matched, then:
 - ❑ dc currents in M_1 and M_2 are $I_{REF} / 2$
 - ❑ dc currents in M_3 and M_4 are I_{REF}
 - ➔ dc currents in M_5 and M_6 are $I_{REF} / 2$
- If a differential-mode input voltage v_d is applied, then ac currents are induced in the differential pair as shown in **Figure 13.17**
 - ❑ AC current in M_1 flows through M_6 to output.
 - ❑ AC current in M_2 flows through M_5 and is induced in M_8 by current-mirror action of the active load.

30

11.3) CMOS Folded-Cascode Op-Amp (Cont)

- Hence, from previous work on diff-amps, **the differential-mode voltage gain** is:

$$A_d = g_{m1} (R_{o6} \parallel R_{o8}) \quad (13.41)$$

where $R_{o6} = g_{m6} (r_{o6}) (r_{o4} \parallel r_{o1})$

and $R_{o8} = g_{m8} (r_{o8} r_{o10})$

- Note: Body effect is neglected. Normally the substrates of all NMOS devices are tied to V_- and the substrates of all PMOS devices are tied to V_+

31

11.3) CMOS Folded-Cascode Op-Amp (Cont)

NEW

Example 13.9

Objective: Determine the differential-mode voltage gain of the **folded cascode diff-amp** in **Figure 13.17**.

Assume circuit and transistor parameters:
 $I_{REF} = 100 \mu\text{A}$, $k'_n = 80 \mu\text{A}/\text{V}^2$, $k'_p = 40 \mu\text{A}/\text{V}^2$, $(W/L) = 25$, and $\lambda_n = \lambda_p = 0.02 \text{ V}^{-1}$.

32

11.3) CMOS Folded-Cascode Op-Amp (Cont)

NEW

Example 13.9 (Cont)

Solution: The transconductances are determined to be

$$g_{m1} = g_{m8} = 2\sqrt{\frac{k'_p}{2} \cdot \frac{W}{L} \cdot I_D} = 2\sqrt{\frac{40\mu}{2} \cdot (25) \cdot \frac{100\mu}{2}} = 316\mu\text{A}/\text{V}$$

and

$$g_{m6} = 2\sqrt{\frac{k'_n}{2} \cdot \frac{W}{L} \cdot I_D} = 2\sqrt{\frac{80\mu}{2} \cdot (25) \cdot \frac{100\mu}{2}} = 447\mu\text{A}/\text{V}$$

33

11.3) CMOS Folded-Cascode Op-Amp (Cont)**NEW****Example 13.9 (Cont)**

The transistor output resistances are found to be

$$r_{o1} = r_{o6} = r_{o8} = r_{o10} = \frac{1}{\lambda_{D}} = \frac{1}{(0.02)(100\mu/2)} = 1M\Omega$$

and

$$r_{o4} = \frac{1}{\lambda_{D4}} = \frac{1}{(0.02)(100\mu)} = 0.5M\Omega$$

34

11.3) CMOS Folded-Cascode Op-Amp (Cont)**NEW****Example 13.9 (Cont)**

The composite output resistances can be determined as

$$R_{o8} = g_{m8}(r_{o8}r_{o10}) = (316\mu)(1M)(1M) = 316M\Omega$$

and

$$R_{o6} = g_{m6}(r_{o6})(r_{o4} \parallel r_{o1}) = (447\mu)(1M)(0.5M \parallel 1M) = 149M\Omega$$

35

11.3) CMOS Folded-Cascode Op-Amp (Cont)

NEW

Example 13.9 (Cont)

The differential-mode voltage gain is then

$$A_d = g_{m1}(R_{o6} \parallel R_{o1}) = (316\mu)(149M \parallel 316M) \cong 32000$$