

UNIVERSITY OF CALIFORNIA
College of Engineering
Department of Electrical Engineering
and Computer Sciences

Homework #9

EECS 140

B. E. Boser

Due 10/29/99 before noon in 497 Cory

Fall 1999

Note: Use the device parameters given in the class handout “Device Parameters & SPICE Models” and also available on the EECS 140 website, <http://kowloon.eecs.berkeley.edu/~courses/140>

- 1) Consider the folded cascode amplifier shown in Fig.1. Neglect body effect in the analysis of the circuit.
 - a) Redraw the circuit showing all branch currents for the following cases:
 - (i) $V_{i1}=V_{i2}$ (ii) $V_{i1}\gg V_{i2}$ (iii) $V_{i1}\ll V_{i2}$. Assume $\lambda=0$.
 - b) Calculate the minimum value for V_B so that M3 and M4 remain saturated.
 - c) Determine the amplifiers output voltage range assuming M4, M6 and M8 are to remain saturated. For a DC value of $V_{id}=0$ ($V_{i1}=V_{i2}$), what is the maximum amplitude of an AC output signal before clipping occurs?
 - d) Calculate the low frequency differential mode gain A_{dm0} of the amplifier.
 - e) Which DC value of V_{id} would be required to center the DC output voltage in the middle of the output range?
 - f) Calculate the unity gain frequency f_u and the non-dominant pole frequency f_{p2} .
 - g) Verify (d) and (f) using SPICE. Perform an AC analysis and printout a Bode plot of the small signal differential gain v_o/v_{id} . Mark the calculated values in your plot.

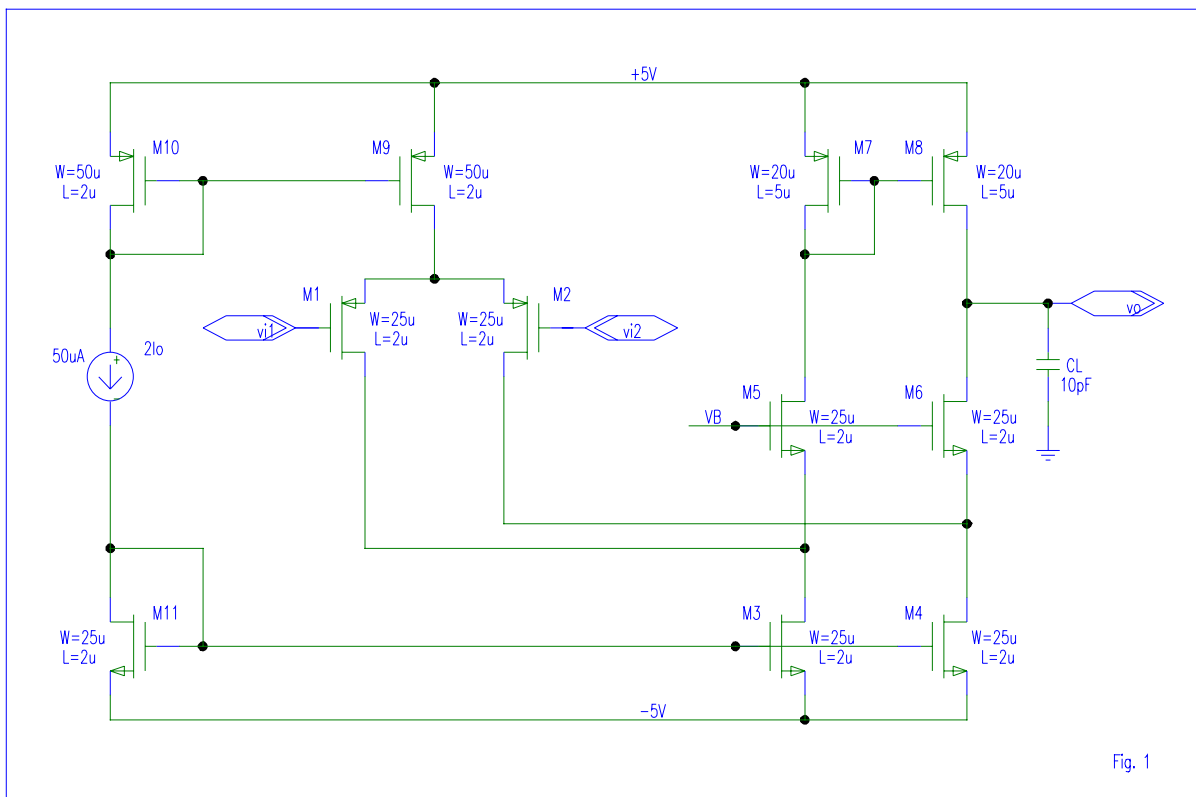

Fig. 1