

**UNIVERSITY OF CALIFORNIA**  
**College of Engineering**  
**Department of Electrical Engineering**  
**and Computer Sciences**

R. W. Brodersen

**EECS 140**  
**Fall 2004**

**PROBLEM SET #5**

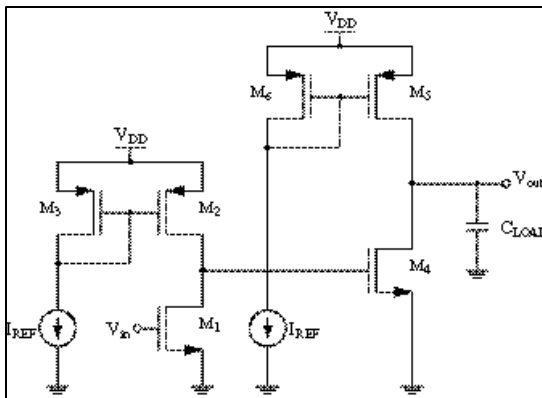

(i)

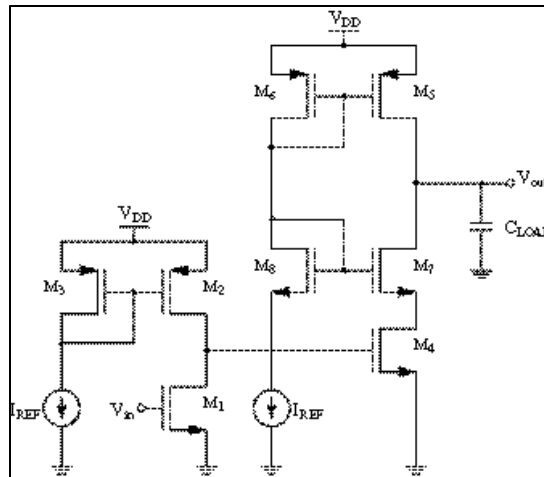

(ii)

All  $W/L=2/0.18$ ,  $V_{DD}=1.8$  V,  $I_{REF}=10$   $\mu$ A. Assume the wells of all devices are tied to their respective sources. Set the DC voltage at  $V_{IN}$  so that the output is at 0.9 V.

**Problem 1**

- a) For circuit (i), calculate the two lowest pole frequencies and compare with SPICE using the pole-zero analysis option (.pz v(vout) vin), explaining any differences. Assume that  $C_{LOAD}=0$  pF.
- b) Use SPICE to produce the Bode plots for phase and magnitude using the .ac analysis option. Draw by hand the piece-wise linear approximations on these same plots, using the pole and zero locations obtained from the .pz analysis in part (a).
- c) Repeat (a) and (b) when  $C_{LOAD}=10$  pF.

**Problem 2**

Repeat problem 1 for circuit (ii).

For problems 1 and 2, use the following SPICE models and the default values from HSPICE for any unspecified parameters. Assume the lambda for layout rules is 0.09  $\mu\text{m}$ , and include the area and perimeter information for all transistors.

```
.model nch nmos level=1 tox=2.5e-9 vto=0.5 kp=140e-6 lambda=0.1
+ gamma=0.5 phi=0.6 capop=0 cgso=5e-10 cgdo=5e-10 cgbo=4e-10
+ cj=6e-4 cjsw=2e-10
```

```
.model pch pmos level=1 tox=2.5e-9 vto=-0.5 kp=65e-6 lambda=0.15
+ gamma=0.5 phi=0.6 capop=0 cgso=5e-10 cgdo=5e-10 cgbo=4e-10
+ cj=6e-4 cjsw=2e-10
```

Note: We are using the constant “lambda” in two different contexts here. They are:

1. Lambda as a measure of device output resistance, where  $r_o = (\lambda \cdot I_{DS})^{-1}$ . The units here are 1/volts
2. Lambda as a design rule parameter. Lambda specifies the minimum dimensions of your devices. The minimum gate length is typically  $2 \cdot \lambda$ . See the figure below. Here, lambda is in units of length, and as specified about, the lambda for layout rules is 0.09  $\mu\text{m}$ . From the figure below, we can see that the area of the source/drain is equal to  $4 \cdot \lambda \cdot W$  and the perimeter of the source/drain is  $8 \cdot \lambda + W$

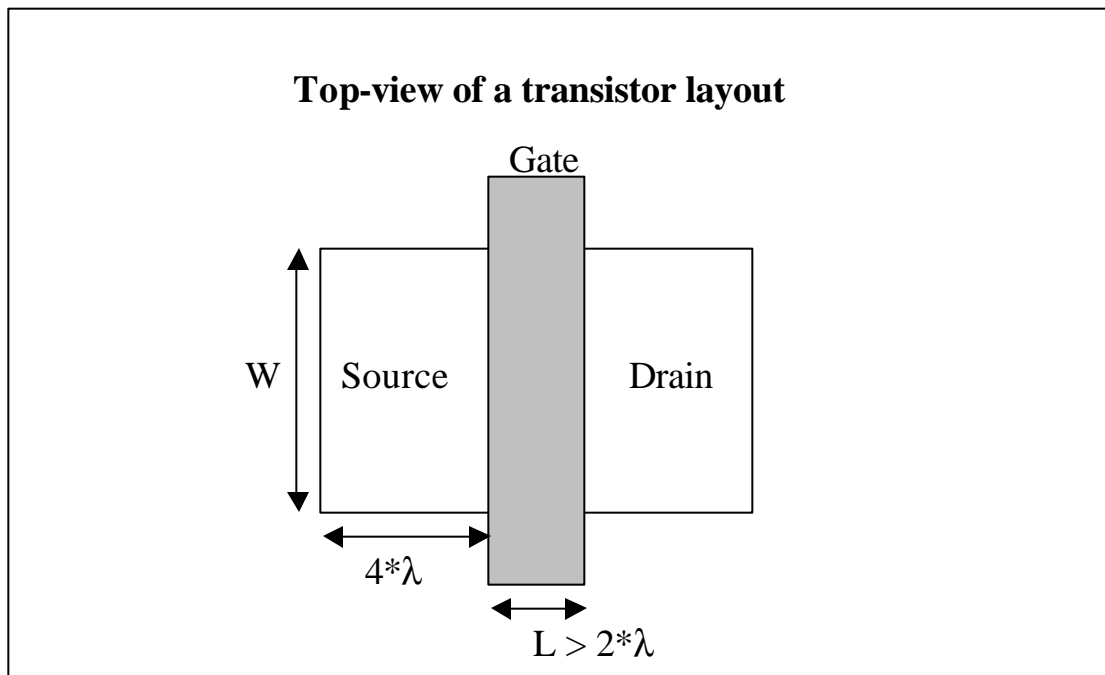

**Problem 3:** Razavi problem 6.6.