

1) Assume all wells are tied to sources. $V_{DD} = 1.8V$. $L_{min} = 0.18\mu m$.

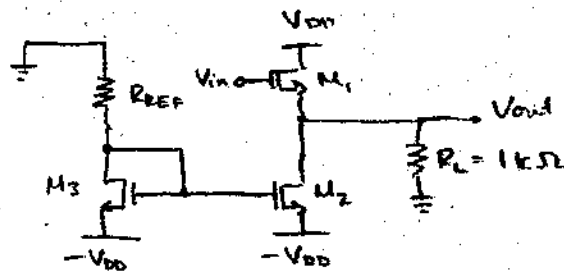

a) $|V_{out}^+| = |V_{out}^-| = 1V$

$$I_a = \frac{|V_{out}^-|}{R_L} = \frac{1V}{1k\Omega} = \boxed{1mA}$$

$$V_{DSAT2} = V_{DD} - |V_{out}^-| = 0.8V$$

$$R_{REF} = \frac{V_{DD} - V_T - V_{DSAT2}}{I_a} = \frac{|V_{out}^-| - V_T}{I_a} = \frac{0.5}{1mA} = \boxed{500\Omega}$$

$$\left(\frac{W}{L}\right)_2 = \frac{2I_a}{k_n'(V_{DSAT2})^2} = \frac{2(1mA)}{(140\mu m)(0.8)^2} = 22.3 \Rightarrow \boxed{\left(\frac{W}{L}\right)_2 = \left(\frac{W}{L}\right)_3 = \frac{4}{0.18}}$$

At peak of output voltage, $I_{DS1} = I_a + I_L$
 $= I_a + \frac{|V_{out}^+|}{R_L}$
 $= 2I_a$

$$V_{DSAT1} = V_{DD} - |V_{out}^+| - V_T = 0.3V$$

$$\left(\frac{W}{L}\right)_1 = \frac{2(2I_a)}{k_n'(V_{DSAT1})^2} = \frac{2(2mA)}{(140\mu m)(0.3)^2} = 317.5 \Rightarrow \boxed{\left(\frac{W}{L}\right)_1 = \frac{59}{0.18}}$$

For a swing between $-1V < V_{out} < 1V$, the maximum efficiency and smallest area occur when

$$\left(\frac{W}{L}\right)_1 = \frac{59}{0.18}, \left(\frac{W}{L}\right)_2 = \left(\frac{W}{L}\right)_3 = \frac{4}{0.18}, R_{REF} = 500\Omega$$

b) The plot of V_{out} vs. V_{in} is attached and shows that the output swings between $\pm 1V$.

1) c) The power into the load is:

$$P_L = \frac{1}{2} \frac{V_o^2}{R} = \frac{1}{2} \frac{(1)^2}{1k\Omega} = \boxed{0.5 \text{ mW}}$$

The total power from the supplies is:

$$P_{\text{supply}} = 3I_Q \cdot V_{DD} = 3(1\text{mA})(1.8\text{V}) = \boxed{5.4 \text{ mW}}$$

$$\text{Efficiency is: } \eta = \frac{P_L}{P_{\text{supply}}} = \boxed{9.3\%}$$

d) From SPICE:

$$\begin{aligned} P_L &= 0.51 \text{ mW} \\ P_{\text{supply}} &= 5.8 \text{ mW} \\ \eta &= 8.9\% \end{aligned}$$

* class a source-follower output stage

```
.model nch nmos level=1 tox=25 vto=0.5 kp=140e-6 lambda=0.1 gamma=0.5 phi=0.6
.model pch pmos level=1 tox=25 vto=-0.5 kp=65e-6 lambda=0.15 gamma=0.5 phi=0.6
```

```
vdd vdd 0 1.8
vss vss 0 -1.8
```

```
vin vin 0 sin (0.65365 1.1439 1)
```

```
m1 vdd vin out out nch w=59u l=0.18u
m2 out 1 vss vss nch w=4u l=0.18u
m3 1 1 vss vss nch w=4u l=0.18u
rref 0 1 500
rload out 0 1k
```

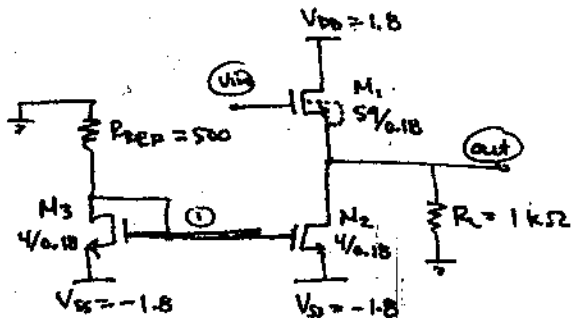

```
.options post=2 nomod
```

```
.probe dc v(out)
.probe tran v(out) power p(rload)
```

```
.meas dc v_lo find v(vin) when v(out)=-1 * find input for vout-
.meas dc v_hi find v(vin) when v(out)=+1 * find input for vout+
.meas dc v_mid param='(v_hi+v_lo)/2' * find midpoint
.meas dc v_amp param='v_hi-v_mid' * find amplitude of input
.meas tran p_load avg p(rload) * find p_load
.meas tran p_sup avg power * find p_supply
.meas tran eff param='100*p_load/p_sup' * find efficiency
```

```
.op
.dc vin -1.8 1.8 0.1
.tran 1m 1
```

```
.end
```

```
***** dc transfer curves tnom= 25.000 temp= 25.000
*****
```

```
v_lo= -4.9023E-01
v_hi= 1.7975E+00
v_mid= 6.5365E-01 ← DC offset voltage
v_amp= 1.1439E+00 ← input amplitude
```

```
**** operating point status is all simulation time is 0.
node =voltage node =voltage node =voltage
+0:1 =-525.7129m 0:out = -43.2211m 0:vdd = 1.8000
+0:vin = 653.6500m 0:vss = -1.8000
```

```
**** mosfets
```

```
subckt
element 0:m1 0:m2 0:m3
model 0:nch 0:nch 0:nch
id 1.0532m 1.0964m 1.0514m
ibs 0. 0. 0.
ibd -18.4322f -17.5678f -12.7429f
vgs 696.8711m 1.2743 1.2743
vds 1.8432 1.7568 1.2743
```

vbs	0.	0.	0.
vth	500.0000m	500.0000m	500.0000m
vdsat	196.8711m	774.2871m	774.2871m
beta	54.3472m	3.6577m	3.5076m
gam eff	500.0000m	500.0000m	500.0000m
gm	10.6994m	2.8321m	2.7159m
gds	88.9286u	93.2587u	93.2587u
gmb	3.4532m	914.0507u	876.5385u
cdtot	3.605e-16	2.330e-17	1.690e-17
cgtot	101.4548f	6.7145f	6.7081f
cstot	97.7935f	6.6301f	6.6301f
cbtot	3.3008f	6.110e-17	6.110e-17
cgs	97.7935f	6.6301f	6.6301f
cgd	3.605e-16	2.330e-17	1.690e-17

***** transient analysis

tnom= 25.000 temp= 25.000

p_load= 5.1407E-04	from= 0.0000E+00	to= 1.0000E+00
p_sup= 5.7969E-03	from= 0.0000E+00	to= 1.0000E+00
eff= 8.8681E+00		

$$P_{load} = 0.51 \text{ mW}$$

$$P_{supply} = 5.8 \text{ mW}$$

$$\eta = 8.9 \%$$

class a source-follower output stage

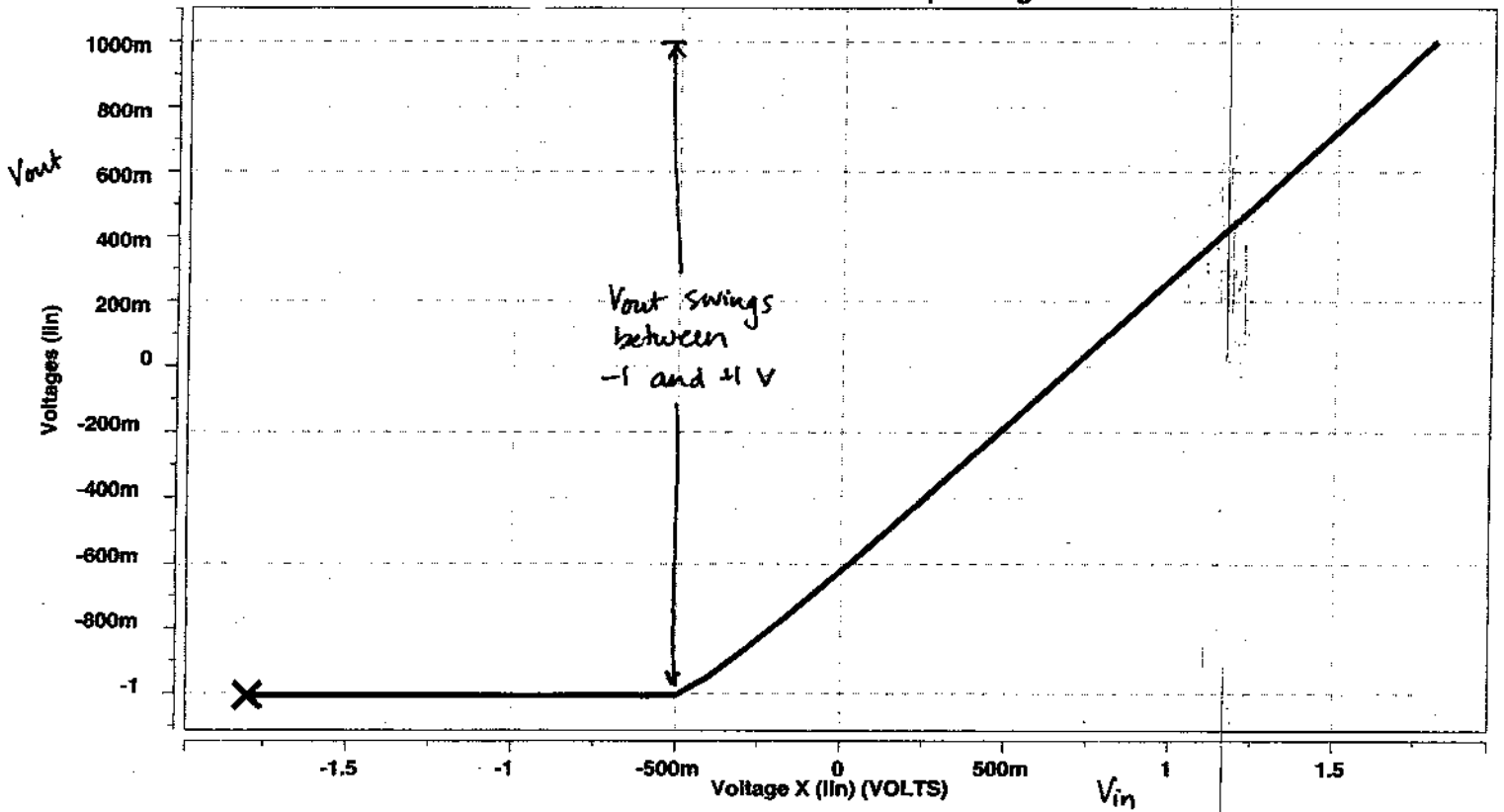

* ~~Fig. 1~~, 1: class a source-follower output stage

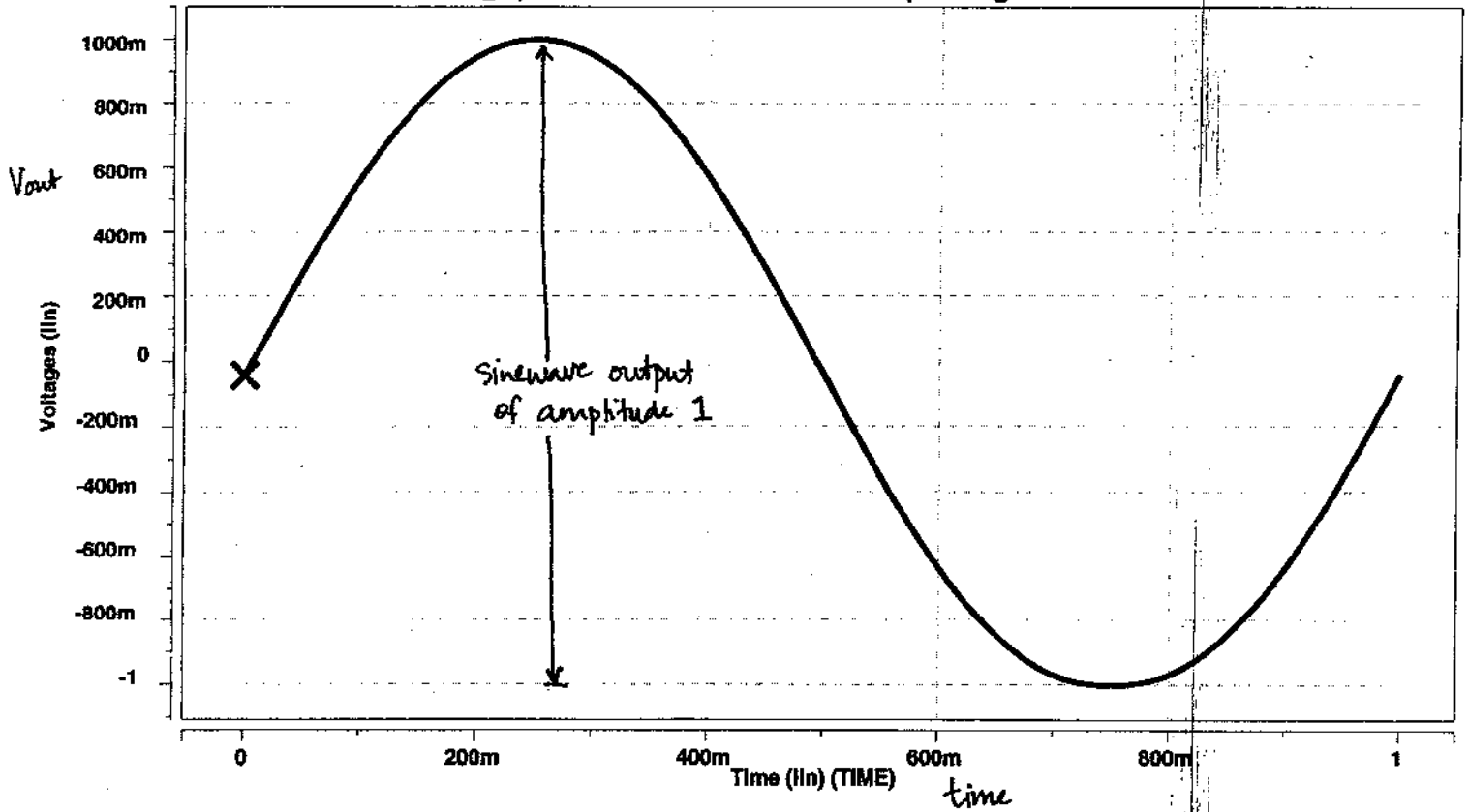

2) Assume all wells are tied to sources. $V_{DD} = 1.8V$, $L_{min} = 0.18\mu m$

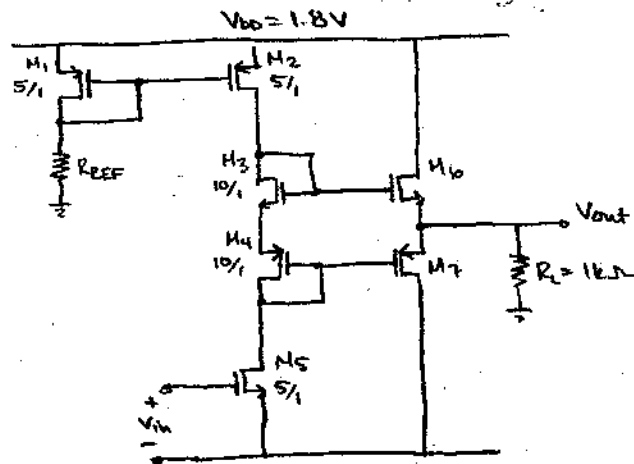

$$a) R_{REF} = \frac{V_{DD} - |V_{T1}| - |V_{DSAT1}|}{|I_{DS1}|} = \frac{1.8 - 0.5 - \sqrt{\frac{2(1\mu)}{65\mu(S)}}}{1\mu}$$

$$R_{REF} = 1.22 \text{ M}\Omega$$

b) When $V_{out} = V_{out}^+$,

$$V_{DD} - |V_{DSAT2}| - V_{T6} - V_{DSAT6} > V_{out}^+$$

$$\therefore V_{DSAT6} < V_{DD} - V_{out}^+ - |V_{DSAT2}| - V_{T6}$$

$$|V_{DSAT2}| = \sqrt{\frac{2(1\mu)}{65\mu(S)}} = 79 \text{ mV}$$

$$\Rightarrow V_{DSAT6} < 0.22 \text{ V}$$

$$I_{DS6} = \frac{V_{out}^+}{R_L} = 1 \text{ mA}$$

$$\Rightarrow \left(\frac{W}{L}\right)_6 = \frac{2I_{DS6}}{k_n'(V_{DSAT6})^2} = 291 \Rightarrow \left(\frac{W}{L}\right)_6 = \frac{53}{0.18}$$

When $V_{out} = V_{out}^-$,

$$V_{DD} - V_{DSAT5} - |V_{T7}| - |V_{DSAT7}| > |V_{out}^-|$$

$$\therefore |V_{DSAT7}| < V_{DD} - V_{DSAT5} - |V_{T7}| - |V_{out}^-|$$

$$V_{DSAT5} = \sqrt{\frac{2(1\mu)}{140\mu(S)}} = 54 \text{ mV}$$

$$\Rightarrow |V_{DSAT7}| < 0.247 \text{ V}$$

2) b) (cont.)

$$|I_{D5,7}| = \frac{|V_{out}|}{R_L} = 1 \text{ mA}$$

$$\Rightarrow \left(\frac{W}{L}\right)_7 = \frac{2|I_{D5,7}|}{k_p' |V_{DS5,7}|^2} = 507 \Rightarrow \boxed{\left(\frac{W}{L}\right)_7 = \frac{92}{0.18}}$$

c) The plot of V_{out} vs V_{in} is attached and shows that the output swings between $\pm 1 \text{ V}$.

d) The total power into the load is:

$$P_L = \frac{1}{2} \frac{\hat{V}_o^2}{R_L} = \boxed{0.5 \text{ mW}}$$

Since the current in M_6 - M_7 is so much larger than that of the gain stage and bias, we consider only the power of the output transistors.

$$P_{supply} = 2V_{DD} \cdot I_{supply} = \frac{2}{\pi} \frac{V_{DD}}{R_L} \cdot \hat{V}_o = \boxed{1.15 \text{ mW}}$$

$$\text{Efficiency is: } \eta = \frac{P_L}{P_{supply}} = \boxed{43.6\%}$$

e) From SPICE:

$$\boxed{\begin{array}{l} P_L = 0.52 \text{ mW} \\ P_{supply} = 1.18 \text{ mW} \\ \eta = 44\% \end{array}}$$

* class ab output stage

```
.model nch nmos level=1 tox=25 vto=0.5 kp=140e-6 lambda=0.1 gamma=0.5 phi=0.6
.model pch pmos level=1 tox=25 vto=-0.5 kp=65e-6 lambda=0.15 gamma=0.5 phi=0.6
```

```
vdd vdd 0 1.8
vss vss 0 -1.8

vin vin vss sin (0.55304 6.8802m 1)

m1 1 1 vdd vdd pch w=5u l=1u
m2 2 1 vdd vdd pch w=5u l=1u
m3 2 2 3 3 nch w=10u l=1u
m4 4 4 3 3 pch w=10u l=1u
m5 4 vin vss vss nch w=5u l=1u
m6 vdd 2 out out nch w=53u l=0.18u
m7 vss 4 out out pch w=92u l=0.18u
rref 1 0 1.22x
rload out 0 1k
```

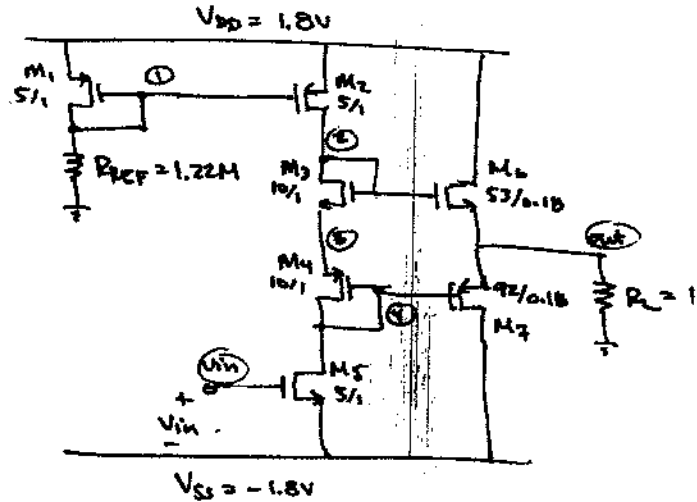

```
.options post=2 nomod
```

```
.probe dc v(out)
.probe tran v(out) power p(rload)
```

```
.meas dc v_hi find v(vin,vss) when v(out)=-1 * find input for vout-
.meas dc v_lo find v(vin,vss) when v(out)=+1 * find input for vout+
.meas dc v_mid param='(v_hi+v_lo)/2' * find midpoint
.meas dc v_amp param='v_hi-v_mid' * find amplitude of input
.meas tran p_load avg p(rload) * find p_load
.meas tran p_sup avg power * find p_supply
.meas tran eff param='100*p_load/p_sup' * find efficiency
```

```
.op
.dc vin 0.5 0.6 1m
.tran 1m 1
```

```
.end
```

```
***** dc transfer curves tnom= 25.000 temp= 25.000
*****
v_hi= 5.5992E-01
v_lo= 5.4616E-01
v_mid= 5.5304E-01 ← dc offset voltage
v_amp= 6.8802E-03 ← input amplitude
```

```
**** operating point status is all simulation time is 0.
node =voltage node =voltage node =voltage
+0:1 = 1.2246 0:2 = 503.7021m 0:3 = -34.9773m
+0:4 = -590.9641m 0:out = -33.9064m 0:vdd = 1.8000
+0:vin = -1.2470 0:vss = -1.8000
```

```
**** mosfets
```

```
subckt
element 0:m1 0:m2 0:m3 0:m4 0:m5 0:m6
```

current due to large λV_{DS} term

model	0:pch	0:pch	0:nch	0:pch	0:nch	0:nch
id	-1.0038u	-1.1037u	1.1037u	-1.1037u	1.1037u	34.4987u
ibs	0.	0.	0.	0.	0.	0.
ibd	5.7541f	12.9630f	-5.3868f	5.5599f	-12.0904f	-18.3391f
vgs	-575.4070m	-575.4070m	538.6794m	-555.9869m	553.0400m	537.6086m
vds	-575.4070m	-1.2963	538.6794m	-555.9869m	1.2090	1.8339
vbs	0.	0.	0.	0.	0.	0.
vth	-500.0000m	-500.0000m	500.0000m	-500.0000m	500.0000m	500.0000m
vdsat	-75.4070m	-75.4070m	38.6794m	-55.9869m	53.0400m	37.6086m
beta	353.0511u	388.1945u	1.4754m	704.2087u	784.6325u	48.7820m
gam eff	500.0000m	500.0000m	500.0000m	500.0000m	500.0000m	500.0000m
gm	26.6225u	29.2726u	57.0682u	39.4264u	41.6169u	1.8346m
gds	138.6017n	138.6017n	104.7268n	152.8083n	98.4635n	2.9152u
gmb	8.5924u	9.4477u	18.4187u	12.7248u	13.4318u	592.1212u
cdtot	5.299e-17	1.194e-16	9.921e-17	1.024e-16	1.113e-16	3.222e-16
cgtot	49.6276f	49.6940f	103.6705f	101.0573f	50.7677f	99.3329f
cstot	46.0421f	46.0421f	92.0843f	92.0843f	46.0421f	87.8484f
cbtot	3.5325f	3.5325f	11.4870f	8.8706f	4.6142f	11.1623f
cgs	46.0421f	46.0421f	92.0843f	92.0843f	46.0421f	87.8484f
cgd	5.299e-17	1.194e-16	9.921e-17	1.024e-16	1.113e-16	3.222e-16

```

subckt
element 0:m7
model 0:pch
id -68.4051u
ibs 0.
ibd 17.6609f
vgs -557.0577m
vds -1.7661
vbs 0.
vth -500.0000m
vdsat -57.0577m
beta 42.0233m
gam eff 500.0000m
gm 2.3978m
gds 8.1118u
gmb 773.8709u
cdtot 5.386e-16
cgtot 167.5158f
cstot 152.4916f
cbtot 14.4856f
cgs 152.4916f
cgd 5.386e-16

```

***** transient analysis tnom= 25.000 temp= 25.000

```

*****
p_load= 5.1742E-04 from= 0.0000E+00 to= 1.0000E+00
p_sup= 1.1755E-03 from= 0.0000E+00 to= 1.0000E+00
eff= 4.4016E+01

```

$P_{load} = 0.52 \text{ mW}$
 $P_{supply} = 1.18 \text{ mW}$
 $\eta = 44\%$

class ab output stage

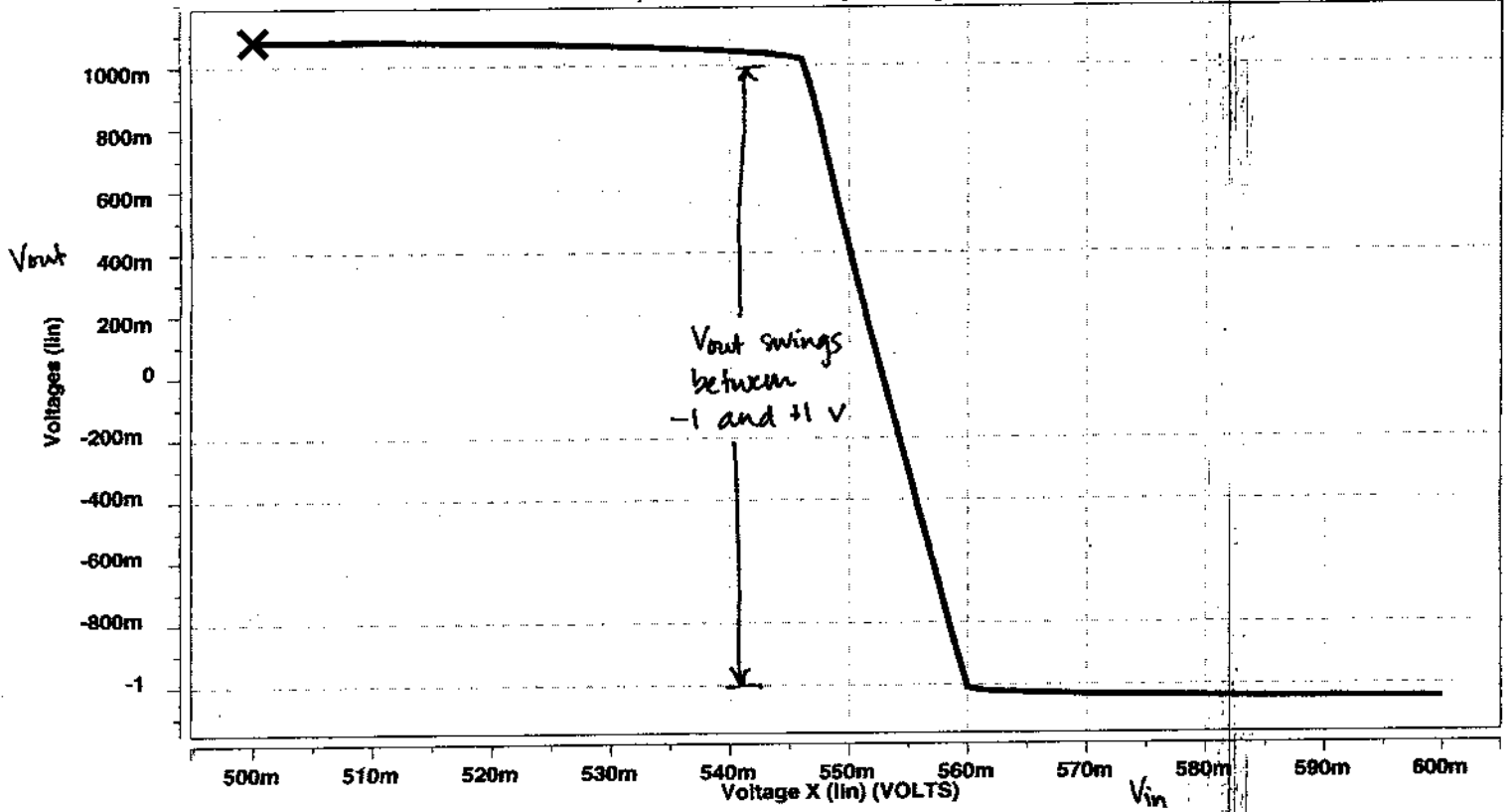

~~class ab~~ class ab output stage

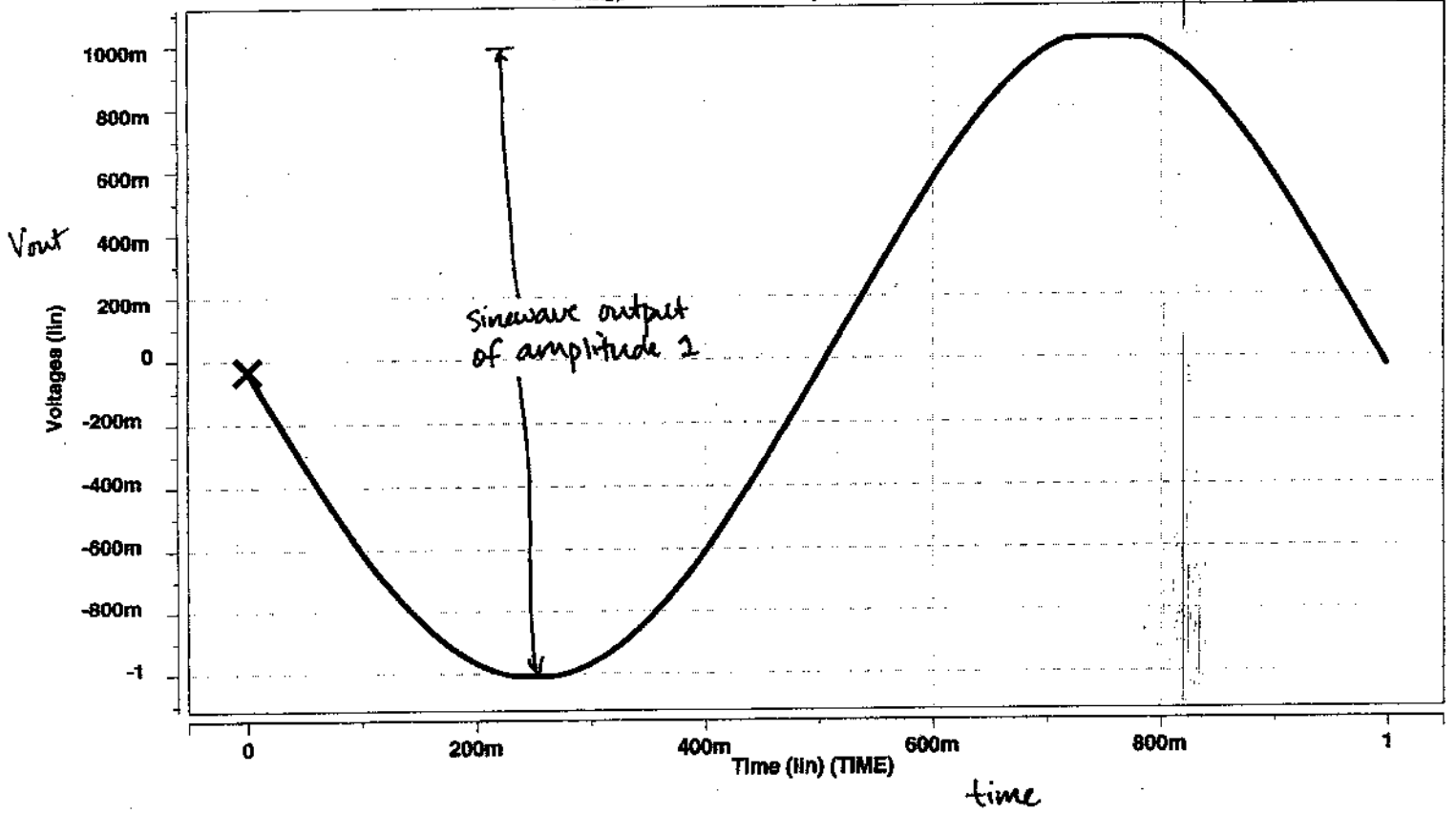

- 3) Assume the wells of all NMOS transistors are tied to the source. All PMOS transistors have their bulk tied to V_{DD} . $V_{DD} = 1.8$, $V_{SS} = -1.8$.

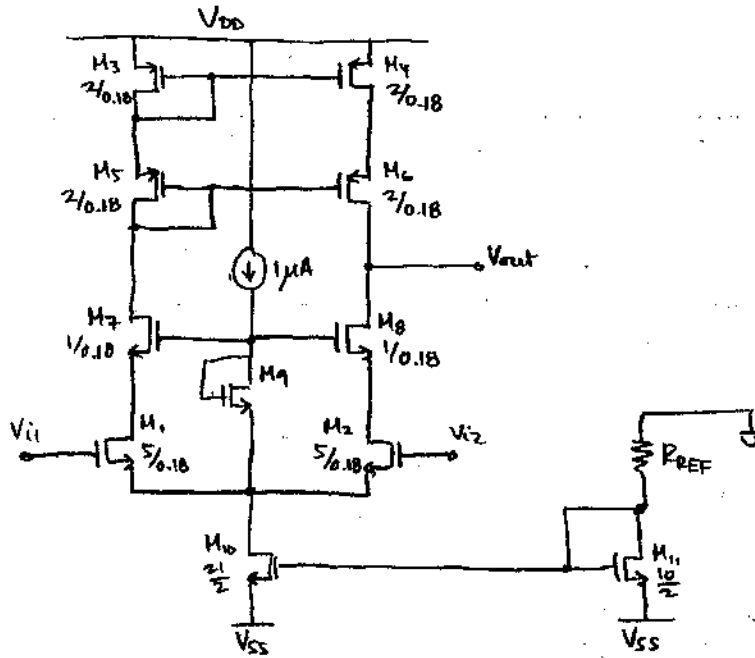

$$a) R_{REF} = \frac{-V_{SS} - V_{T11} - V_{DSAT11}}{I_{DS11}}$$

$$I_{DS11} = 10 \mu A$$

$$V_{DSAT11} = \sqrt{\frac{2I}{k' \frac{W}{L}}} = 0.169 V$$

$$\therefore R_{REF} = \frac{1.8 - 0.5 - 0.169}{10 \mu} = \boxed{113 \text{ k}\Omega}$$

b) SPICE plot of V_{out} vs V_{id} is attached.

(1) At the low end, when $V_{out} < V_{ic} - V_{T2}$ transistor M_2 goes into the linear regime. Thus, this occurs when $V_{out} < -0.5V$

(2) When $V_{out} < V_{DD} - V_{T8}$, transistor M_8 goes into the linear regime. Thus, $V_{out} < V_{ic} - V_{T2} - V_{DSAT2} + V_{T9} + V_{DSAT9} - V_{T8}$

$$V_{out} < V_{ic} + V_{DSAT9} - V_{DSAT2} - V_{T8}$$

$$V_{DSAT9} = \sqrt{\frac{2(10)}{140 \mu (\frac{10}{2})}} = 0.378V \Rightarrow V_{out} < -0.29V$$

(3) At the high end, when $V_{out} > V_{DD} - |V_{DSAT4}|$ transistor M_4 goes into the linear regime.

$$V_{DSAT4} = V_{DSAT6} = \sqrt{\frac{2(10)}{65 (\frac{2}{0.18})}} = 0.166V$$

Thus, this occurs when $V_{out} > 1.63V$

3)

b) (cont.)

(4) When $V_{out} > V_{DD} - |V_{DSAT4}| - |V_{T4}| - |V_{DSAT6}|$ transistor M_6 goes into the linear regime

Thus, this occurs when $V_{out} > 0.97V$

So, the four breakpoints are:

$$\begin{aligned} V_{out} &= -0.5V \\ V_{out} &= -0.29V \\ V_{out} &= 0.97V \\ V_{out} &= 1.63V \end{aligned}$$

c) SPICE plot of V_{out} vs V_{ic} is attached.

Starting at $V_{ic} = V_{SS}$:

(1) All transistors are initially off until $V_{ic} = V_T + V_{SS} = -1.2V$

(2) All transistors are in saturation when $V_{ic} > V_{SS} + V_{T2} + |V_{DSAT2}| + |V_{DSAT10}|$

$$V_{DSAT2} = \sqrt{\frac{2(10)}{140(5/0.18)}} = 72 \text{ mV}$$

$$V_{DSAT10} = 0.169V$$

\therefore Transistors in saturation when $V_{ic} > -1.06V$

(3) When the transistors are in saturation, by symmetry, the output voltage is $V_{out} = V_{DD} - |V_{T4}| - |V_{DSAT4}| - |V_{T6}| - |V_{DSAT6}|$

Notice that the common-mode gain does not depend on the cascode transistors M_7 and M_8 . Thus, even when these go into triode, there is no breakpoint.

The breakpt. occurs when M_2 goes into linear, which occurs when $V_{ic} > V_{out} + V_{T2}$.

Thus, $V_{ic} > V_{DD} - |V_{T4}| - |V_{DSAT4}| - |V_{T6}| - |V_{DSAT6}| + V_{T2}$

$$|V_{T6}| = 0.5 + 0.5(\sqrt{0.6 + 0.5 + 0.166} - \sqrt{0.6}) = 0.675$$

$\therefore V_{ic} > 0.79V$

So, the three breakpoints are:

$$\begin{aligned} V_{ic} &= -1.3V \\ V_{ic} &= -1.06V \\ V_{ic} &= 0.79V \end{aligned}$$

3) d) Calculate $A_{dm} = \frac{v_{out}}{v_{id}}$ when $v_{ic} = v_{id} = 0$.

$$\frac{v_{out}}{v_{id}} = g_{m2} (g_{m3} r_{o3} r_{o2} \parallel (1+\chi) g_{m6} r_{o6} r_{o4})$$

$$g_{m2} = \sqrt{2(140\mu A)(\frac{5}{0.18})(10\mu)} = 280\mu S$$

$$g_{m3} = \sqrt{2(140\mu A)(\frac{1}{0.18})(10\mu)} = 125\mu S$$

$$r_{o3} = r_{o2} = \frac{1}{0.1(10\mu)} = 1M\Omega$$

$$g_{m6} = \sqrt{2(65\mu A)(\frac{2}{0.18})(10\mu)} = 120\mu S$$

$$r_{o6} = r_{o4} = \frac{1}{0.15(10\mu)} = 666k\Omega$$

$$\chi_6 = \frac{\gamma}{2(2\phi + V_{DS})^{1/2}} = \frac{0.5}{2(0.6 + 0.5 + 0.166)^{1/2}} = 0.22$$

$$\therefore R_{out} = 42.8M\Omega$$

$$A_{dm} = g_m R_{out} = 12k$$

e) $R_{out} = g_{m3} r_{o3} r_{o2} \parallel (1+\chi) g_{m6} r_{o6} r_{o4}$

$$R_{out} = 42.8M\Omega$$

The main discrepancy is due to the fact that χ_{DS} is ignored when calculating currents, g_m , r_o . The value of V_{DS} for $M_3 - M_6$ are relatively large, causing errors greater than 10%.

From SPICE:

$$A_{dm} = 14.2k$$

$$R_{out} = 49.5M\Omega$$

* ~~telescopic~~ telescopic opamp

```
.model nch nmos level=1 tox=25 vto=0.5 kp=140e-6 lambda=0.1 gamma=0.5 phi=0.6
.model pch pmos level=1 tox=25 vto=-0.5 kp=65e-6 lambda=0.15 gamma=0.5 phi=0.6
```

```
vdd vdd 0 1.8
vss vss 0 -1.8
```

* set up common mode and differential inputs

```
vic vic 0 0
vid vid 0 0
e1 vi1 vic vid 0 0.5
e2 vi2 vic vid 0 -0.5
```

* telescopic opamp

```
m1 5 vi1 7 7 nch w=5u l=0.18u
m2 6 vi2 7 7 nch w=5u l=0.18u
m3 1 1 vdd vdd pch w=2u l=0.18u
m4 2 1 vdd vdd pch w=2u l=0.18u
m5 3 3 1 vdd pch w=2u l=0.18u
m6 out 3 2 vdd pch w=2u l=0.18u
m7 3 4 5 5 nch w=1u l=0.18u
m8 out 4 6 6 nch w=1u l=0.18u
m9 4 4 7 7 nch w=1u l=10u
ibias vdd 4 1u
```

* simple current source of 10ua

```
rref 0 8 113k
m10 7 8 vss vss nch w=21u l=2u
m11 8 8 vss vss nch w=10u l=2u
```

.options post=2 nomod

```
.op
.dc vid -10m 10m 0.01m
.dc vic -1.8 1.8 1m
```

.tf v(out) vid * find adm (for vic=0)

.end

```
***** operating point information tnom= 25.000 temp= 25.000
*****
```

node	=voltage	node	=voltage	node	=voltage
+0:1	= 1.1365	0:2	= 1.1365	0:3	= 300.2043m
+0:4	= 289.5090m	0:5	= -370.4047m	0:6	= -370.4047m
+0:7	= -573.1370m	0:8	= -1.1359	0:out	= 300.2043m
+0:vdd	= 1.8000	0:vi1	= 0.	0:vi2	= 0.
+0:vic	= 0.	0:vid	= 0.	0:vss	= -1.8000

**** mosfets

subckt	0:m1	0:m2	0:m3	0:m4	0:m5	0:m6
element	0:m1	0:m2	0:m3	0:m4	0:m5	0:m6
model	0:nch	0:nch	0:pch	0:pch	0:pch	0:pch
id	10.6117u	10.6117u	-10.6117u	-10.6117u	-10.6117u	-10.6117u
ibs	0.	0.	0.	0.	6.6348f	6.6348f
ibd	-2.0273f	-2.0273f	6.6348f	6.6348f	14.9980f	14.9980f

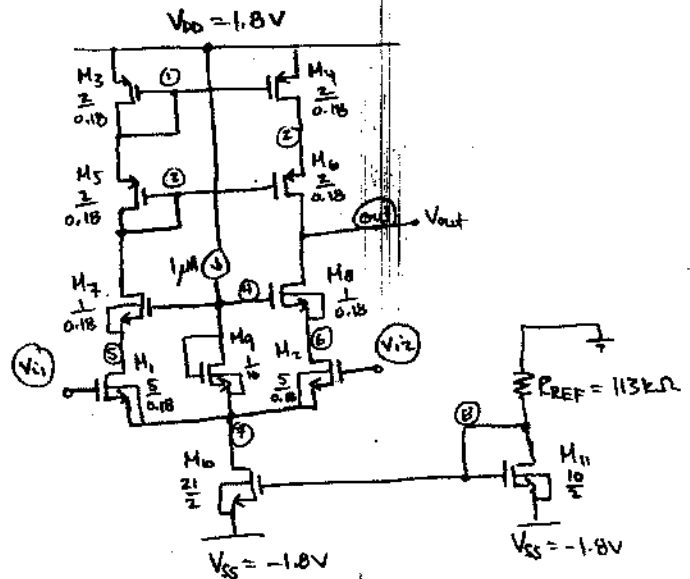

vgs	573.1370m	573.1370m	-663.4822m	-663.4822m	-836.3136m	-836.3136m
vds	202.7323m	202.7323m	-663.4822m	-663.4822m	-836.3136m	-836.3136m
vbs	0.	0.	0.	0.	663.4822m	663.4822m
vth	500.0000m	500.0000m	-500.0000m	-500.0000m	-674.7253m	-674.7253m
vdsat	73.1370m	73.1370m	-163.4822m	-163.4822m	-161.5883m	-161.5883m
beta	3.9677m	3.9677m	794.0995u	794.0995u	812.8229u	812.8229u
gam eff	500.0000m	500.0000m	500.0000m	500.0000m	500.0000m	500.0000m
gm	290.1876u	290.1876u	129.8211u	129.8211u	131.3427u	131.3427u
gds	1.0401u	1.0401u	1.4477u	1.4477u	1.4143u	1.4143u
gmb	93.6577u	93.6577u	41.8996u	41.8996u	29.2120u	29.2120u
cdtot	3.360e-18	3.360e-18	4.399e-18	4.399e-18	5.545e-18	5.545e-18
cgtot	8.9423f	8.9423f	3.4517f	3.4517f	3.4202f	3.4202f
cstot	8.2876f	8.2876f	3.3150f	3.3150f	3.3150f	3.3150f
cbtot	6.513e-16	6.513e-16	1.323e-16	1.323e-16	9.965e-17	9.965e-17
cgs	8.2876f	8.2876f	3.3150f	3.3150f	3.3150f	3.3150f
cgd	3.360e-18	3.360e-18	4.399e-18	4.399e-18	5.545e-18	5.545e-18

subckt	0:m7	0:m8	0:m9	0:m10	0:m11
element	0:nch	0:nch	0:nch	0:nch	0:nch
model	0:nch	0:nch	0:nch	0:nch	0:nch
id	10.6117u	10.6117u	999.9983n	22.2234u	10.0521u
ibs	0.	0.	0.	0.	0.
ibd	-6.7061f	-6.7061f	-8.6265f	-12.2686f	-6.6411f
vgs	659.9136m	659.9136m	862.6459m	664.1091m	664.1091m
vds	670.6089m	670.6089m	862.6459m	1.2269	664.1091m
vbs	0.	0.	0.	0.	0.
vth	500.0000m	500.0000m	500.0000m	500.0000m	500.0000m
vdsat	159.9136m	159.9136m	362.6459m	164.1091m	164.1091m
beta	829.9363u	829.9363u	15.2077u	1.6503m	746.4876u
gam eff	500.0000m	500.0000m	500.0000m	500.0000m	500.0000m
gm	132.7181u	132.7181u	5.5150u	270.8373u	122.5054u
gds	994.4811n	994.4811n	92.0584n	1.9795u	942.6132n
gmb	42.8346u	42.8346u	1.7800u	87.4124u	39.5385u
cdtot	2.223e-18	2.223e-18	1.589e-16	9.490e-16	2.446e-16
cgtot	1.7272f	1.7272f	94.0047f	403.0798f	191.7355f
cstot	1.6575f	1.6575f	92.0843f	386.7540f	184.1686f
cbtot	6.744e-17	6.744e-17	1.7615f	15.3768f	7.3223f
cgs	1.6575f	1.6575f	92.0843f	386.7540f	184.1686f
cgd	2.223e-18	2.223e-18	1.589e-16	9.490e-16	2.446e-16

**** small-signal transfer characteristics

v(out)/vid = 14.2489k ← Adm
input resistance at vid = 1.000e+20
output resistance at v(out) = 49.4927x ← Rout

telescopic opamp

