

University of California
Berkeley
College of Engineering
Department of Electrical Engineering
and Computer Science

Robert W. Brodersen
EECS140

Analog Circuit Design

**Lectures
on
OUTPUT STAGES**

Output Stages

O-1

Large Signal Swing
Distortion
Power
Efficiency

Typical OP Amp :

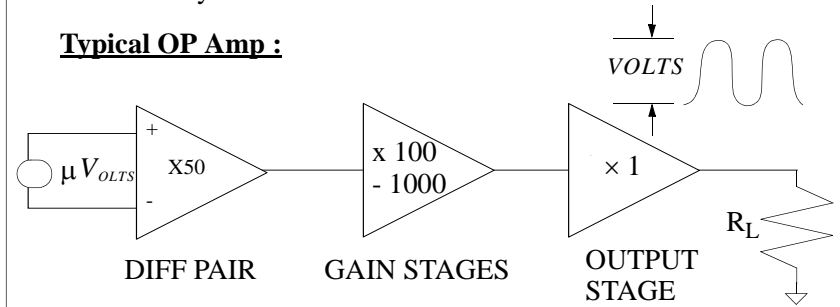

O-2

Power :

Total power from supplies = P_{SUPPLY}

Power into Load = P_{LOAD}

$$Efficiency = \frac{P_{LOAD}}{P_{SUPPLIES}} (\%)$$

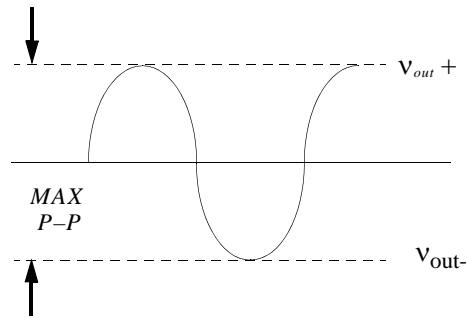

v_{out+} = desired plus swing
 v_{out-} = desired neg. swing

Typically output load is low impedance (but not always!)
If it is, a source follower is a possible output stage.

O-3

$$A_{vmax} \approx \frac{1}{1 + \chi}$$

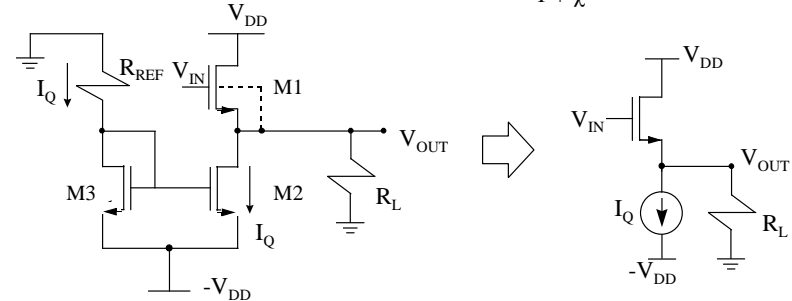

O-4

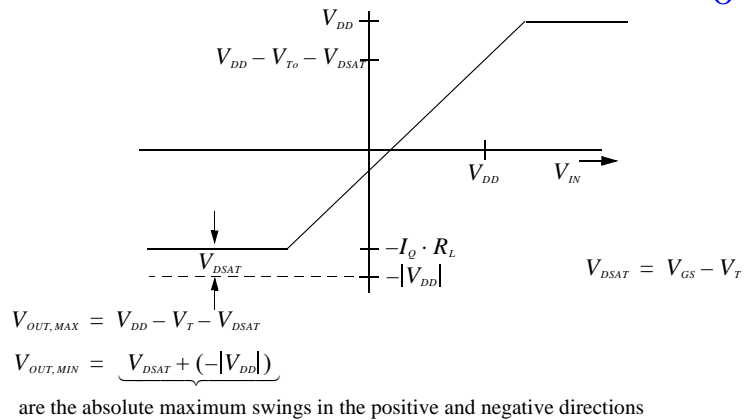

V_{out-} , V_{out+} are the desired positive and negative swings
They typically should be equal for symmetric outputs

O-5

$$\textcircled{1} \quad I_Q = \frac{|V_{out-}|}{R_L}$$

$$\textcircled{2} \quad R_{REF} = \frac{V_{DD} - V_T - V_{DSAT}}{I_Q} \approx \frac{V_{DD} - V_T}{I_Q}$$

To set $\left(\frac{W}{L}\right)_2$ use V_{out-}

$$V_{DSAT} = (V_{DD} - |V_{OUT-}|)$$

$$\textcircled{3} \quad \left(\frac{W}{L}\right)_2 = \left(\frac{2 \cdot I_Q}{k'}\right) \cdot \frac{1}{(V_{DD} - |V_{OUT-}|)^2}$$

Find the W/L of M1:

$$I_{DS1} = I_Q + I_L = I_Q + \frac{V_{OUT+}}{R_L}$$

O-6

$$\frac{k'}{2} \cdot \left(\frac{W}{L}\right)_1 \cdot (V_{DD} - V_{OUT+} - V_T)^2 = I_Q + \frac{V_{OUT+}}{R_L}$$

$$\textcircled{4} \quad \left(\frac{W}{L}\right)_1 = \frac{2 \cdot \left(I_Q + \frac{V_{OUT+}}{R_L}\right)}{k' \cdot (V_{DD} - V_{OUT+} - V_T)^2}$$

e.g. $R_L = 300\Omega$ $|V_{OUT+}| = |V_{OUT-}| = 3V$

$$V_{DD} = 5V \quad I_Q = 10ma \quad R_{REF} = \frac{3 - 0.7}{10ma} = 230\Omega$$

$$\left(\frac{W}{L}\right)_2 = \frac{2 \times 10^{-2}}{90 \times 10^{-6}} \cdot \frac{1}{(5 - 3)^2} = 56$$

$$\left(\frac{W}{L}\right)_1 = \frac{2 \cdot (2 \times 10^{-2})}{90 \times 10^{-6} \cdot (5 - 3 - 0.7)^2} = 263$$

O-7

$$GAIN = \frac{g_m \cdot (R_L \parallel r_o)}{1 + g_m \cdot (R_L \parallel r_o)} \approx \frac{g_m \cdot R_L}{1 + g_m \cdot R_L}$$

$$R_{OUT} = \frac{1}{g_m} \parallel R_L$$

$$g_m = \left(2 \cdot k' \cdot \frac{W}{L} \cdot I_{DS}\right)^{\frac{1}{2}} = (2 \times 90 \times 10^{-6} \times 263 \times 10^{-2})^{\frac{1}{2}} = 22 \times 10^{-3}$$

$$\frac{1}{g_m} = 45\Omega$$

$$GAIN = \frac{R_L}{\frac{1}{g_m} + R_L} = \frac{300}{45 + 300} = 0.87$$

$$R_{OUT} = \frac{1}{g_m} \parallel R_L = 45 \parallel 300 \approx 40\Omega$$

O-8

$$Power = \sum V_{SUPPLY} \cdot (CurrentOut)$$

$$Power@V_{out} = 0V \quad DC Power without any Signal$$

$$Power = (-I_{M3}) \cdot (-V_{DD}) + (-I_{M2}) \cdot (-V_{DD}) + (I_{M1}) \cdot V_{DD}$$

$$= 3 \cdot I_Q \cdot V_{DD} = 3 \cdot (10 \times 10^{-3}) \cdot 5 = 150mW$$

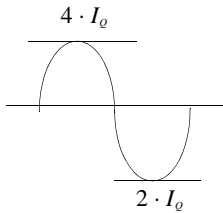

$$Average = 3 \cdot I_Q$$

$$Efficiency = \frac{Power\ to\ Load}{3 \cdot I_Q \cdot V_{DD}} (\%)$$

O-10

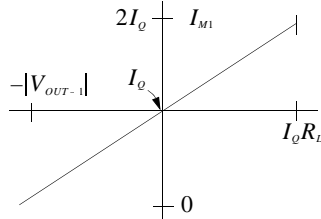

$$I_{M1} = I_Q + I_{RL} = I_Q + \frac{V_{OUT}}{R_L}$$

$$|V_{OUT-}| = |V_{OUT+}|$$

$$P_{SUPPLY} = \frac{1}{T_c} \cdot \int_0^{T_c} (I_{DS}(m1) \cdot V_{DD}) dt + 2 \cdot I_Q \cdot |V_{DD}|$$

$$= 3 \cdot I_Q \cdot V_{DD} = 150mW$$

$$Efficiency = \frac{P_{LOAD}}{TotalPower} = \frac{15mW}{150mW} = 10\%$$

$$= \left(\frac{\frac{1}{2} \cdot I_Q \cdot R_L}{3 \cdot I_Q \cdot V_{DD}} \right) = \frac{1}{6} \cdot \left(\frac{I_Q \cdot R_L}{V_{DD}} \right) < 16 \% \text{ MAX}$$

O-9

$$V_{OFFSET} = V_{IN}|_{V_{out} = 0V}$$

$$V_{IN} = V_{GS1} = V_{TO} + \underbrace{\left(\frac{2 \cdot I_{DS}}{k' \cdot \frac{W}{L}} \right)^{\frac{1}{2}}}_{\Delta V} = 0.7 + \left(\frac{2 \times 10 \times 10^{-3}}{90 \times 10^{-6} \times 263} \right) = 1.6V$$

Efficiency (Sine Wave)

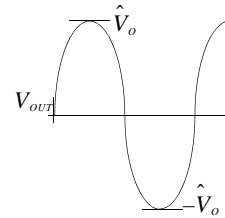

$$\hat{V}_o = PeakVoltage$$

$$P_L = \frac{1}{2} \cdot \hat{V}_o \cdot \hat{I}_o = \frac{1}{2} \cdot (I_Q \cdot R_L) \cdot I_Q = \frac{1}{2} \cdot I_Q^2 \cdot R_L$$

$$= \frac{1}{2} \cdot 10^{-4} \times 300 = 15mW$$

O-11

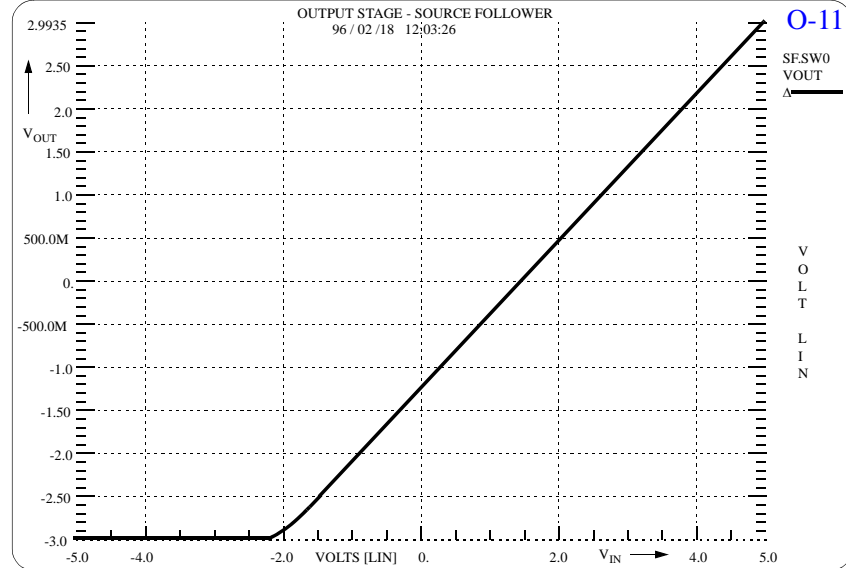

O-12

output stage - source follower

```

****
* reading file: hothooks\commercial\spice\hspice.ini
.model nch mmos level = 1 tox = 170 vto = 0.7 kp = 900e-6 lambda = 0.01
+ gamma = 0.5 pin = 0.6 capp = 0 cgs0 = 5e-10 cgd0 = 5e-10 cjb0 = 4e-10 cj = 1e-4
.model pch pmos level = 1 tox = 170 vto = -0.7 kp = 300e-6 lambda = 0.01
+ gamma = 0.5 pin = 0.6 capp = 0 cgs0 = 3e-11 cgd0 = 3e-11 cjb0 = 4e-10 cj = 6e-4
.option nopage post=2 abs1 = 1e-10 rel1 = 1e-4 absmos = 1e-8 relmos = 1e-4
+ absv = 1e-6 relv = 1e-4
.options nomod

*name drain gate source bulk model
m1 vdd vin vout vout nch l=1u w=253u
m2 vout d3 vdd- vdd- nch l=1u w=56u
m3 d3 d3 vdd- vdd- nch l=1u w=56u
ref 0 d3 230
*load vout vdd- 1ma

*initial operating point
*makes it do the power calculation
.measure tot_power avg power

.de vin -5 5 1
.print dc (m1) (m2) (m3) v(vout)
.op
.if v(vout)>0 vin

```

Small-signal transfer characteristics

v(vout)/vin	= 86.50433m
input resistance at v(vout)	= 1.000e+20
output resistance at v(vout)	= 38.2335

O-13

Bipolar version

Bipolar :

O-14

Bipolar (Cont.)

$V_{MAX} = V_{CC} - V_{BE} = |V_{MAX-}|$ for symmetry

$P_L = \frac{1}{2} \cdot (V_{CC} - V_{BE}) \cdot I_Q \cdot R_L$

$Efficiency = \frac{\frac{1}{2} \cdot (V_{CC} - V_{BE}) \cdot I_Q \cdot R_L}{3 \cdot I_Q \cdot V_{CC}} = \frac{1}{6} \cdot \frac{(V_{CC} - V_{BE})}{V_{CC}}$

$= \frac{1}{6} \cdot \left(\frac{5 - 0.6}{5}\right) = 15\%$

$I_C = I_S \cdot e^{\frac{V_{BE}}{V_T}}$

$V_{BE} = V_{Th} \cdot \ln \frac{I_C}{I_S} = 0.06 \cdot \log \frac{I_C}{I_S}$

O-15

More voltage range

Inverter Output Stage :

O-16

$$I_Q = \frac{|V_{MAX+}|}{R_L} = \frac{3V}{300} = 10^{-2}$$

$$V_{DSAT} = V_{DD} - V_{MAX+} = \left(\frac{2 \cdot I_Q}{k' \cdot \frac{W}{L}} \right)^{\frac{1}{2}}$$

$$\textcircled{1} \left(\frac{W}{L} \right)_2 = \frac{2 \cdot I_Q}{k'} \cdot \frac{1}{(V_{DD} - V_{MAX+})^2} = 166$$

$$I_Q \cdot R_{REF} = V_{DD} - V_{SG} = V_{DD} - |V_T| - V_{DSAT} = V_{DD} - |V_T| - (V_{DD} - V_{MAX+})$$

$$\textcircled{2} R_{REF} = \frac{V_{MAX+} - |V_T|}{I_Q} = \frac{3 - 0.7}{10^{-2}} = 230\Omega$$

$$= \frac{I_Q \cdot R_L - |V_T|}{I_Q} = R_L - \frac{V_{To}}{I_Q}$$

O-18

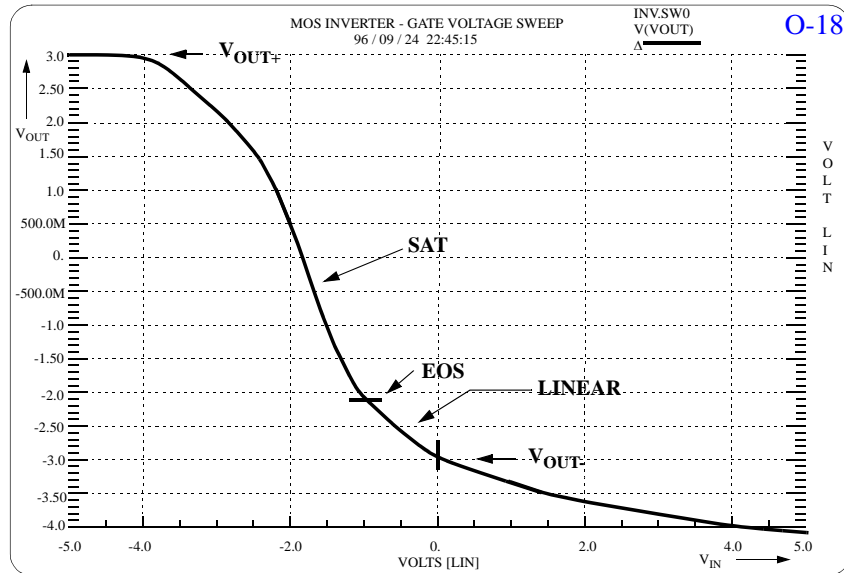

O-17

(Cont.)

Let $V_{GS} = V_{DD}$

$$I_{DS,M1} = k' \cdot \left(\frac{W}{L} \right)_1 \cdot \left(V_{GS} - V_T - \frac{V_{DS}}{2} \right) \cdot V_{DS}$$

$$2 \cdot I_Q = k' \cdot \left(\frac{W}{L} \right)_1 \cdot \left(V_{GS} - V_T - \frac{(V_{DD} - |V_{OUT-1}|)}{2} \right) \cdot (V_{DD} - |V_{OUT-1}|)$$

$$\left(\frac{W}{L} \right)_1 = \frac{2 \cdot I_Q}{k' \cdot \left(V_{DD} - V_{To} - \frac{(V_{DD} - |V_{OUT-1}|)}{2} \right) \cdot (|V_{Dbl-1}| - |V_{OUT-1}|)} = 34$$

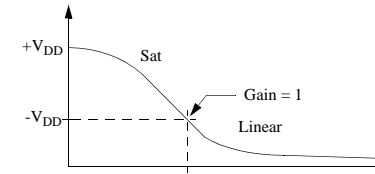

O-19

```

*****
* Reading file: /home/ks/commercial/hspice/hspice.in
*
model nch mos level = 1 tox = 170 vto = 0.7 kp = 90.0e-6 lambda = 0.01
+ gamma = 0.5 phi = 0.6 cpgop = 0 gso=5e-10 gdo=5e-10 sgbo=-4e-10 cf=1e-4
model pch mos level = 1 tox = 170 vto = -0.7 kp = 30.0e-6 lambda = 0.01
+ gamma = 0.5 phi = 0.6 cpgop = 0 gso=3e-11 gdo=3e-11 sgbo=-4e-10 cf=6e-4
option noqpc post=2 absi = 1e-10 redi = 1e-4 absmos = 1e-8 reimos=1e-4
+ abs=1e-6 reiv=1e-4

options nomod

*name drain gate source bulk model
m1 vout vin vdd vdd nch l=l w=34u
m2 vout vin vdd vdd nch l=l w=34u
m3 vr vr vdd vdd pch l=l w=166u

ref vr 0 230
r1 vout 0 300

*vin vin 0 sin(1 1)
vin vin 0 -4.15
vdd vdd 0 5.0
vdd vdd 0 -5.0

dc vin 5 5 5
print dc (m1) (m2) (m3) v(vout)
*tran 1 1
*print tran i(m1) v(vout)
op
at v(vout,0) vin
measure tot_power avg power

* 1 is the i/s of m1
*initial operating point
*transfer function between (vcd) an vin
*makes it do the power calculation

* sweep the input voltage
end
    
```

Class B : Push - Pull

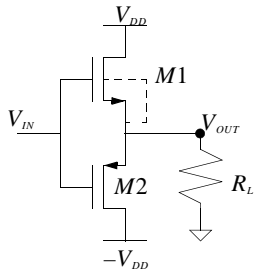

$$V_{i1} \approx V_{T0} + \gamma \cdot (V_{DD})^{\frac{1}{2}}$$

Push - Pull (Cont.)

With Biasing - Remove Dead Zone which gives crossover distortion.

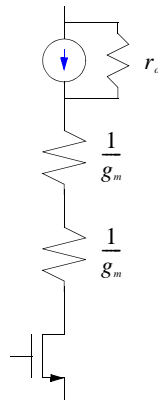
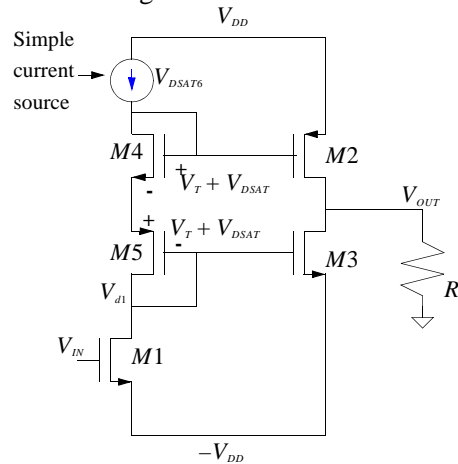

Push - Pull (Cont.)

V_{OUT+} is set by M1; V_{out} by M2

$$I_{DS1} = \frac{V_{OUT+}}{R_L} = \frac{k'_n}{2} \cdot \left(\frac{W}{L}\right)_1 \cdot (V_{DD} - V_{OUT+} - V_T)^2$$

$$\left(\frac{W}{L}\right)_1 = \frac{2 \cdot V_{OUT+}}{R_L \cdot k'_n \cdot (V_{DD} - V_{OUT+} - V_{Tn})^2}$$

$$\left(\frac{W}{L}\right)_2 = \frac{2 \cdot V_{OUT-}}{R_L \cdot k'_p \cdot (V_{DD} - V_{OUT-} - V_{Tp})^2}$$

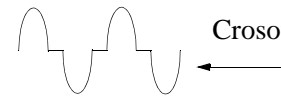
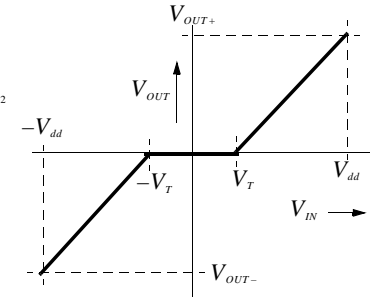

Crossover Distortion

$$|V_T| \approx \left| V_{T0,P} + \gamma \cdot (V_{SB})^{\frac{1}{2}} \right|$$

$$\gamma \cdot [(2 \cdot \phi_f + V_{SB})^{1/2} - (2 \cdot \phi_f)^{1/2}]$$

Push - Pull (Cont.)

Level Shifter :

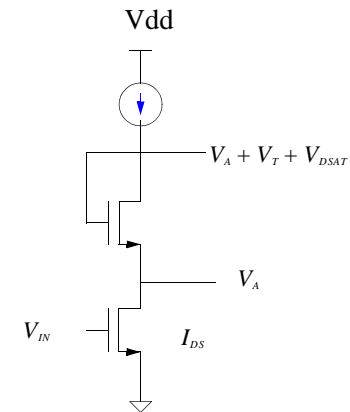

Push - Pull (Cont.)

O-24

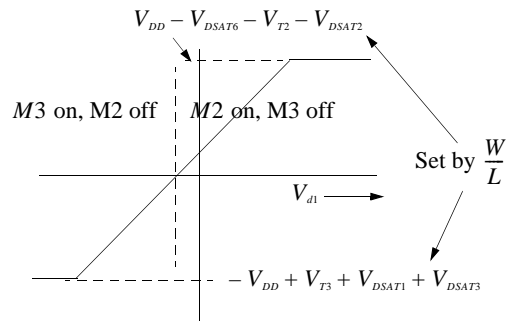

Push - Pull (Cont.)

O-25

Efficiency with sine wave input :

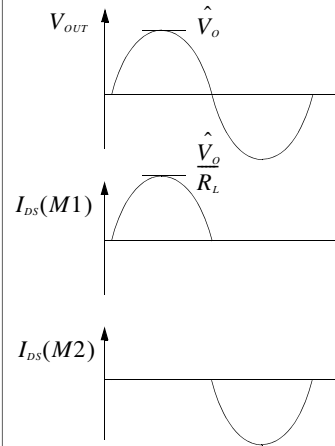

$\hat{V}_o = \text{Peak } V_{OUT}$

$I_{SUPPLY} = \frac{1}{T} \cdot \int_0^{T_c} I_{DS}(t) dt = \frac{1}{\pi} \cdot \frac{\hat{V}_o}{R_L} = \text{Ave Current from each supply}$

$P_{SUPPLY} = 2 \cdot V_{DD} \cdot I_{SUPPLY} = \frac{2}{\pi} \cdot \frac{V_{DD}}{R_L} \cdot \hat{V}_o$

$P_{LOAD} = \frac{1}{2} \cdot \frac{\hat{V}_o^2}{R_L}$

$Efficiency = \frac{P_{LOAD}}{P_{SUPPLY}} = \frac{\pi}{4} \cdot \frac{\hat{V}_o}{V_{DD}} \Rightarrow 79\%$
 If $\hat{V}_o = V_{DD}$